

# LM7131

## Tiny High Speed Single Supply Operational Amplifier

### General Description

The LM7131 is a high speed bipolar operational amplifier available in a tiny SOT23-5 package. This makes the LM7131 ideal for space and weight critical designs. Single supply voltages of 3V and 5V provides good video performance, wide bandwidth, low distortion, and high PSRR and CMRR. This makes the amplifier an excellent choice for desktop and portable video and computing applications. The amplifier is supplied in DIPs, surface mount 8-pin packages, and tiny SOT23-5 packages.

Tiny amplifiers are so small they can be placed anywhere on a board close to the signal source or next to an A-to-D input. Good high speed performance at low voltage makes the LM7131 a preferred part for battery powered designs.

### Features

- Tiny SOT23-5 package saves space-typical circuit layouts take half the space of SO-8 designs.
- Guaranteed specs at 3V, 5V, and  $\pm 5V$  supplies
- Typical supply current 7.0 mA at 5V, 6.5 mA at 3V
- 4V output swing with +5V single supply
- Typical total harmonic distortion of 0.1% at 4 MHz
- 70 MHz Gain-Bandwidth Product
- 90 MHz  $-3$  dB bandwidth at 3V and 5V, Gain = +1
- Designed to drive popular video A/D converters
- 40 mA output can drive  $50\Omega$  loads
- Differential gain and phase 0.25% and  $0.75^\circ$  at  $A_V = +2$

### Applications

- Driving video A/D converters
- Video output for portable computers and PDAs
- Desktop teleconferencing
- High fidelity digital audio
- Video cards

### Connection Diagrams

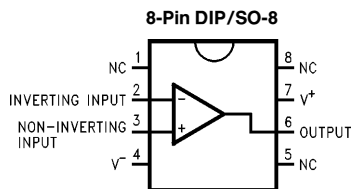

Top View

TL/H/12313-1

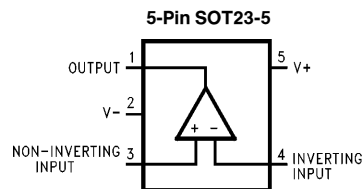

Top View

TL/H/12313-2

Package	Ordering Information	NSC Drawing Number	Package Marking	Supplied as
8-Pin DIP	LM7131ACN	N08E	LM7131ACN	rails
8-Pin DIP	LM7131BCN	N08E	LM7131BCN	rails
8-Pin SO-8	LM7131ACM	M08A	LM7131ACM	rails
8-Pin SO-8	LM7131BCM	M08A	LM7131BCM	rails
8-Pin SO-8	LM7131ACMX	M08A	LM7131ACM	2.5k units tape and reel
8-Pin SO-8	LM7131BCMX	M08A	LM7131BCM	2.5k units tape and reel
5-Pin SOT 23-5	LM7131ACM5	MA05A	A02A	250 units on tape and reel
5-Pin SOT 23-5	LM7131BCM5	MA05A	A02B	250 units on tape and reel
5-Pin SOT 23-5	LM7131ACM5X	MA05A	A02A	3k units tape and reel
5-Pin SOT 23-5	LM7131BCM5X	MA05A	A02B	3k units tape and reel

## Absolute Maximum Ratings (Note 1)

If Military/Aerospace specified devices are required, please contact the National Semiconductor Sales Office/Distributors for availability and specifications.

ESD Tolerance (Note 2)	2000V
Differential Input Voltage	±2.0
Voltage at Input/Output Pin	(V <sup>+</sup> ) + 0.1V, (V <sup>-</sup> ) - 0.3V
Supply Voltage (V <sup>+</sup> - V <sup>-</sup> )	12V
Current at Input Pin	±5 mA
Current at Output Pin (Note 3)	±80 mA
Current at Power Supply Pin	±80 mA

Lead Temperature (soldering, 10 sec)	260°C
Storage Temperature Range	- 65°C to + 150°C
Junction Temperature (Note 4)	150°C

## Operating Ratings

Supply Voltage (V <sup>+</sup> - V <sup>-</sup> )	2.7V ≤ V ≤ 12V
Junction Temperature Range	0°C ≤ T <sub>J</sub> ≤ + 70°C
LM7131AC, LM7131BC	
Thermal Resistance (θ <sub>J-A</sub> )	
N Package, 8-Pin Molded DIP	115°C/W
SO-8 Package, 8-Pin Surface Mount	165°C/W
M05A Package, 5-Pin Surface Mount	325°C/W

**3V DC Electrical Characteristics** Unless otherwise specified, all limits guaranteed for T<sub>J</sub> = 25°C, V<sup>+</sup> = 3V, V<sup>-</sup> = 0V, V<sub>CM</sub> = V<sub>O</sub> = V<sup>+</sup>/2 and R<sub>L</sub> = 150Ω. **Boldface** limits apply at the temperature extremes.

Symbol	Parameter	Conditions	Typ (Note 5)	LM7131AC Limit (Note 6)	LM7131BC Limit (Note 6)	Units
V <sub>OS</sub>	Input Offset Voltage		0.02	2 <b>4</b>	7 <b>10</b>	mV max
TCV <sub>OS</sub>	Input Offset Voltage Average Drift		10			μV/°C
I <sub>B</sub>	Input Bias Current		20	30 <b>40</b>	30 <b>40</b>	μA max
I <sub>OS</sub>	Input Offset Current		0.35	3.5 <b>5</b>	3.5 <b>5</b>	μA max
CMRR	Common Mode Rejection Ratio	0V ≤ V <sub>CM</sub> ≤ 0.85V (Video Levels)	75	60 <b>55</b>	60 <b>55</b>	dB min
CMRR	Common Mode Rejection Ratio	0.85V ≤ V <sub>CM</sub> ≤ 1.7V (Mid-Range)	70	55 <b>50</b>	55 <b>50</b>	dB min
+PSRR	Positive Power Supply Rejection Ratio	V <sup>+</sup> = 3V, V <sup>-</sup> = 0V V <sup>+</sup> = 3V to 6.5V	75	65 <b>60</b>	65 <b>60</b>	dB min
-PSRR	Negative Power Supply Rejection Ratio	V <sup>-</sup> = -3V, V <sup>+</sup> = 0V V <sup>-</sup> = -3V to -6.5V	75	65 <b>60</b>	65 <b>60</b>	dB min
V <sub>CM</sub>	Input Common-Mode Voltage Range	V <sup>+</sup> = 3V For CMRR ≥ 50 dB	0.0	0.0 <b>0.00</b>	0.0 <b>0.00</b>	V min
			2.0	1.70 <b>1.60</b>	1.70 <b>1.60</b>	V max
A <sub>VOL</sub>	Voltage Gain	R <sub>L</sub> = 150Ω, V <sub>O</sub> = 0.250V to 1.250V	60	55 <b>50</b>	55 <b>50</b>	dB
C <sub>IN</sub>	Common-Mode Input Capacitance		2			pF

**3V DC Electrical Characteristics** Unless otherwise specified, all limits guaranteed for  $T_J = 25^\circ\text{C}$ ,  $V^+ = 3\text{V}$ ,  $V^- = 0\text{V}$ ,  $V_{CM} = V_O = V^+/2$  and  $R_L = 150\Omega$ . **Boldface** limits apply at the temperature extremes. (Continued)

Symbol	Parameter	Conditions	Typ (Note 5)	LM7131AC Limit (Note 6)	LM7131BC Limit (Note 6)	Units
$V_O$	Output Swing High	$V^+ = 3\text{V}$ , $R_L = 150\Omega$ terminated at 0V	2.6	2.3 <b>2.0</b>	2.3 <b>2.0</b>	V min
	Low	$V^+ = 3\text{V}$ , $R_L = 150\Omega$ terminated at 0V	0.05	0.15 <b>0.20</b>	0.15 <b>0.20</b>	V max
	High	$V^+ = 3\text{V}$ , $R_L = 150\Omega$ terminated at 1.5V	2.6	2.3 <b>2.0</b>	2.3 <b>2.0</b>	V min
	Low	$V^+ = 3\text{V}$ , $R_L = 150\Omega$ terminated at 1.5V	0.5	0.8 <b>1.0</b>	0.8 <b>1.0</b>	V max
$V_O$	Output Swing High	$V^+ = 3\text{V}$ , $R_L = 600\Omega$ terminated at 0V	2.73			V max
$V_O$	Output Swing Low	$V^+ = 3\text{V}$ , $R_L = 600\Omega$ terminated at 0V	0.06			V max
$I_{SC}$	Output Short Circuit Current	Sourcing, $V_O = 0\text{V}$	65	45 <b>40</b>	45 <b>40</b>	mA min
		Sinking, $V_O = 3\text{V}$	40	25 <b>20</b>	25 <b>20</b>	mA min
$I_S$	Supply Current	$V^+ = +3\text{V}$	6.5	8.0 <b>8.5</b>	8.0 <b>8.5</b>	mA max

**3V AC Electrical Characteristics** Unless otherwise specified, all limits guaranteed for  $T_J = 25^\circ\text{C}$ ,  $V^+ = 3\text{V}$ ,  $V^- = 0\text{V}$ ,  $V_{CM} = V_O = V^+/2$  and  $R_L = 150\Omega$ . **Boldface** limits apply at the temperature extremes.

Symbol	Parameter	Conditions	Typ (Note 5)	LM7131AC Limit (Note 6)	LM7131BC Limit (Note 6)	Units
T.H.D.	Total Harmonic Distortion	$F = 4\text{ MHz}$ , $A_V = +2$ $R_L = 150\Omega$ , $V_O = 1.0V_{PP}$	0.1			%
	Differential Gain	(Note 10)	0.45			%
	Differential Phase	(Note 10)	0.6			°
SR	Slew Rate	$R_L = 150\Omega$ , $C_L = 5\text{ pF}$ (Note 7)	120			V/ $\mu\text{S}$
SR	Slew Rate	$R_L = 150\Omega$ , $C_L = 20\text{ pF}$ (Note 7)	100			V/ $\mu\text{S}$
GBW	Gain-Bandwidth Product		70			MHz
	Closed-Loop – 3 dB Bandwidth		90			MHz

**5V DC Electrical Characteristics** Unless otherwise specified, all limits guaranteed for  $T_J = 25^\circ\text{C}$ ,  $V^+ = 5\text{V}$ ,  $V^- = 0\text{V}$ ,  $V_{CM} = V_O = V^+ / 2$  and  $R_L = 150\Omega$ . **Boldface** limits apply at the temperature extremes.

Symbol	Parameter	Conditions	Typ (Note 5)	LM7131AC Limit (Note 6)	LM7131BC Limit (Note 6)	Units
$V_{OS}$	Input Offset Voltage		0.02	2 <b>4</b>	7 <b>10</b>	mV max
$TCV_{OS}$	Input Offset Voltage Average Drift		10			$\mu\text{V}/^\circ\text{C}$
$I_B$	Input Bias Current		20	30 <b>40</b>	30 <b>40</b>	$\mu\text{A}$ max
$I_{OS}$	Input Offset Current		0.35	3.5 <b>5</b>	3.5 <b>5</b>	$\mu\text{A}$ max
CMRR	Common Mode Rejection Ratio	$0\text{V} \leq V_{CM} \leq 1.85\text{V}$ (Video Levels)	75	65 <b>60</b>	65 <b>60</b>	dB min
CMRR	Common Mode Rejection Ratio	$1.85\text{V} \leq V_{CM} \leq 3.7\text{V}$ (Mid-Range)	70	55 <b>50</b>	55 <b>50</b>	dB min
+ PSRR	Positive Power Supply Rejection Ratio	$V^+ = 5\text{V}$ , $V^- = 0\text{V}$ $V^+ = 5\text{V}$ to $10\text{V}$	75	65 <b>60</b>	65 <b>60</b>	dB min
- PSRR	Negative Power Supply Rejection Ratio	$V^- = -5\text{V}$ , $V^+ = 0\text{V}$ $V^- = -5\text{V}$ to $-10\text{V}$	75	65 <b>60</b>	65 <b>60</b>	dB min
$V_{CM}$	Input Common-Mode Voltage Range	$V^+ = 5\text{V}$ For CMRR $\geq 50$ dB	0.0	- 0.0 <b>0.00</b>	- 0.0 <b>0.00</b>	V min
			4.0	3.70 <b>3.60</b>	3.70 <b>3.60</b>	V max
$A_{VOL}$	Voltage Gain	$R_L = 150\Omega$ , $V_O = 0.250\text{V}$ to $2.250\text{V}$	70	60 <b>55</b>	60 <b>55</b>	dB min
$C_{IN}$	Common-Mode Input Capacitance		2			pF
$V_O$	Output Swing High	$V^+ = 5\text{V}$ , $R_L = 150\Omega$ terminated at $0\text{V}$	4.5	4.3 <b>4.0</b>	4.3 <b>4.0</b>	V min
	Low	$V^+ = 5\text{V}$ , $R_L = 150\Omega$ terminated at $0\text{V}$	0.08	0.15 <b>0.20</b>	0.15 <b>0.20</b>	V max
	High	$V^+ = 5\text{V}$ , $R_L = 150\Omega$ terminated at $2.5\text{V}$	4.5	4.3 <b>4.0</b>	4.3 <b>4.0</b>	V min
	Low	$V^+ = 5\text{V}$ , $R_L = 150\Omega$ terminated at $2.5\text{V}$	0.5	0.8 <b>1.0</b>	0.8 <b>1.0</b>	V max
$V_O$	Output Swing High	$V^+ = 5\text{V}$ , $R_L = 600\Omega$ terminated at $0\text{V}$	4.70			V max
$V_O$	Output Swing Low	$V^+ = 5\text{V}$ , $R_L = 600\Omega$ terminated at $0\text{V}$	0.07			V max
$I_{SC}$	Output Short Circuit Current	Sourcing, $V_O = 0\text{V}$	65	45 <b>40</b>	45 <b>40</b>	mA min
		Sinking, $V_O = 5\text{V}$	40	25 <b>20</b>	25 <b>20</b>	mA min
$I_S$	Supply Current	$V^+ = +5\text{V}$	7.0	8.5 <b>9.0</b>	8.5 <b>9.0</b>	mA max

**5V AC Electrical Characteristics** Unless otherwise specified, all limits guaranteed for  $T_J = 25^\circ\text{C}$ ,  $V^+ = 5\text{V}$ ,  $V^- = 0\text{V}$ ,  $V_{\text{CM}} = V_O = V^+ / 2$  and  $R_L = 150\Omega$ . **Boldface** limits apply at the temperature extremes.

Symbol	Parameter	Conditions	Typ (Note 5)	LM7131AC Limit (Note 6)	LM7131BC Limit (Note 6)	Units
T.H.D.	Total Harmonic Distortion	$F = 4\text{ MHz}$ , $A_V = +2$ $R_L = 150\Omega$ , $V_O = 2.0V_{\text{PP}}$	0.1			%
	Differential Gain	(Note 10)	0.25			%
	Differential Phase	(Note 10)	0.75			$^\circ$
SR	Slew Rate	$R_L = 150\Omega$ , $C_L = 5\text{ pF}$ (Note 8)	150			$\text{V}/\mu\text{s}$
SR	Slew Rate	$R_L = 150\Omega$ , $C_L = 20\text{ pF}$ (Note 8)	130			$\text{V}/\mu\text{s}$
GBW	Gain-Bandwidth Product		70			MHz
	Closed-Loop $-3\text{ dB}$ Bandwidth		90			MHz
$e_n$	Input-Referred Voltage Noise	$f = 1\text{ kHz}$	11			$\frac{\text{nV}}{\sqrt{\text{Hz}}}$
$i_n$	Input-Referred Current Noise	$f = 1\text{ kHz}$	3.3			$\frac{\text{pA}}{\sqrt{\text{Hz}}}$

**$\pm 5\text{V DC Electrical Characteristics}$**  Unless otherwise specified, all limits guaranteed for  $T_J = 25^\circ\text{C}$ ,  $V^+ = 5\text{V}$ ,  $V^- = -5\text{V}$ ,  $V_{\text{CM}} = V_O = 0\text{V}$  and  $R_L = 150\Omega$ . **Boldface** limits apply at the temperature extremes.

Symbol	Parameter	Conditions	Typ (Note 5)	LM7131AC Limit (Note 6)	LM7131BC Limit (Note 6)	Units
$V_{\text{OS}}$	Input Offset Voltage		0.02	2 <b>4</b>	7 <b>10</b>	mV max
$\text{TCV}_{\text{OS}}$	Input Offset Voltage Average Drift		10			$\mu\text{V}/^\circ\text{C}$
$I_B$	Input Bias Current		20	30 <b>40</b>	30 <b>40</b>	$\mu\text{A}$ max
$I_{\text{OS}}$	Input Offset Current		0.35	3.5 <b>5</b>	3.5 <b>5</b>	$\mu\text{A}$ max
CMRR	Common Mode Rejection Ratio	$-5\text{V} \leq V_{\text{CM}} \leq 3.7\text{V}$	75	65 <b>60</b>	65 <b>60</b>	dB min
+PSRR	Positive Power Supply Rejection Ratio	$V^+ = 5\text{V}$ , $V^- = 0\text{V}$ $V^+ = 5\text{V to } 10\text{V}$	75	65 <b>60</b>	65 <b>60</b>	dB min
-PSRR	Negative Power Supply Rejection Ratio	$V^- = -5\text{V}$ , $V^+ = 0\text{V}$ $V^- = -5\text{V to } -10\text{V}$	75	65 <b>60</b>	65 <b>60</b>	dB min
$V_{\text{CM}}$	Input Common-Mode Voltage Range	$V^+ = 5\text{V}$ , $V^- = -5\text{V}$ For CMRR $\geq 60\text{ dB}$	-5.0 4.0	-5.0 <b>-5.0</b> 3.70 <b>3.60</b>	-5.0 <b>-5.0</b> 3.70 <b>3.60</b>	V min V max
$A_{\text{VOL}}$	Voltage Gain	$R_L = 150\Omega$ , $V_O = -2.0\text{ to } +2.0$	70	55 <b>50</b>	55 <b>50</b>	dB

**± 5V DC Electrical Characteristics** Unless otherwise specified, all limits guaranteed for  $T_J = 25^\circ\text{C}$ ,  $V^+ = 5\text{V}$ ,  $V^- = -5\text{V}$ ,  $V_{\text{CM}} = V_O = 0\text{V}$  and  $R_L = 150\Omega$ . **Boldface** limits apply at the temperature extremes. (Continued)

Symbol	Parameter	Conditions	Typ (Note 5)	LM7131AC Limit (Note 6)	LM7131BC Limit (Note 6)	Units
$C_{\text{IN}}$	Common-Mode Input Capacitance		2			pF
$V_O$	Output Swing High	$V^+ = 5\text{V}$ , $V^- = -5\text{V}$ $R_L = 150\Omega$ terminated at 0V	4.5	4.3 <b>4.0</b>	4.3 <b>4.0</b>	V min
	Low		-4.5	-3.5 <b>-2.5</b>	-3.5 <b>-2.5</b>	V max
$I_{\text{SC}}$	Output Short Circuit Current	Sourcing, $V_O = -5\text{V}$	65	45 <b>40</b>	45 <b>40</b>	mA min
		Sinking, $V_O = 5\text{V}$	40	25 <b>20</b>	25 <b>20</b>	mA min
$I_S$	Supply Current	$V^+ = +5\text{V}$ , $V^- = -5\text{V}$	7.5	9 <b>10</b>	9 <b>10</b>	mA max

**± 5V AC Electrical Characteristics** Unless otherwise specified, all limits guaranteed for  $T_J = 25^\circ\text{C}$ ,  $V^+ = 5\text{V}$ ,  $V^- = -5\text{V}$ ,  $V_{\text{CM}} = V_O = 0\text{V}$  and  $R_L = 150\Omega$ . **Boldface** limits apply at the temperature extremes.

Symbol	Parameter	Conditions	Typ (Note 5)	LM7131AC Limit (Note 6)	LM7131BC Limit (Note 6)	Units
T.H.D.	Total Harmonic Distortion	$F = 4\text{ MHz}$ , $A_V = -2$ $R_L = 150\Omega$ , $V_O = 4.0V_{\text{PP}}$	1.5			%
	Differential Gain	(Note 10)	0.25			%
	Differential Phase	(Note 10)	1.0			°
SR	Slew Rate	$R_L = 150\Omega$ , $C_L = 5\text{ pF}$ (Note 9)	150			V/ $\mu\text{s}$
SR	Slew Rate	$R_L = 150\Omega$ , $C_L = 20\text{ pF}$ (Note 9)	130			V/ $\mu\text{s}$
GBW	Gain-Bandwidth Product		70			MHz
	Closed-Loop -3 dB Bandwidth		90			MHz

**Note 1:** Absolute maximum Ratings indicate limits beyond which damage to the device may occur. Operating Ratings indicate conditions for which the device is intended to be functional, but specific performance is not guaranteed. For guaranteed specifications and the test conditions, see the Electrical characteristics.

**Note 2:** Human body model, 1.5 k $\Omega$  in series with 100 pF.

**Note 3:** Applies to both single-supply and split-supply operation. Continuous short circuit operation at elevated ambient temperature can result in exceeding the maximum allowed junction temperature of 150°C.

**Note 4:** The maximum power dissipation is a function of  $T_{\text{J(max)}}$ ,  $\theta_{\text{JA}}$ , and  $T_A$ . The maximum allowable power dissipation at any ambient temperature is  $P_D = (T_{\text{J(max)}} - T_A)/\theta_{\text{JA}}$ . All numbers apply for packages soldered directly into a PC board.

**Note 5:** Typical values represent the most likely parametric norm.

**Note 6:** All limits are guaranteed by testing or statistical analysis.

**Note 7:** Connected as voltage follower with 1.5V step input. Number specified is the slower of the positive and negative slew rates.  $V^+ = 3\text{V}$  and  $R_L = 150\Omega$  connected to 1.5V. Amp excited with 1 kHz to produce  $V_O = 1.5 V_{\text{PP}}$ .

**Note 8:** Connected as Voltage Follower with 4.0V step input. Number specified is the slower of the positive and negative slew rates.  $V^+ = 5\text{V}$  and  $R_L = 150\Omega$  connected to 2.5V. Amp excited with 1 kHz to produce  $V_O = 4 V_{\text{PP}}$ .

**Note 9:** Connected as Voltage Follower with 4.0V step input. Number specified is the slower of the positive and negative slew rates.  $V^+ = 5\text{V}$ ,  $V^- = -5\text{V}$  and  $R_L = 150\Omega$  connected to 0V. Amp excited with 1 kHz to produce  $V_O = 4 V_{\text{PP}}$ .

**Note 10:** Differential gain and phase measured with a 4.5 MHz signal into a 150 $\Omega$  load, Gain = +2.0, between 0.6V and 2.0V output.

# Typical Performance Characteristics

**LM7131 Supply Current vs Supply Voltage**

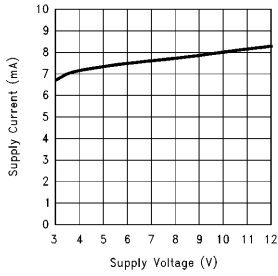

**LM7131 Input Current vs Temperature @ 3V**

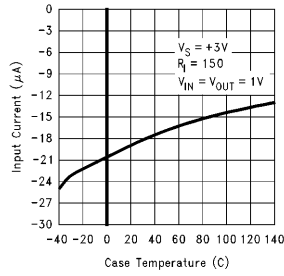

**LM7131 Input Current vs Temperature @ 5V**

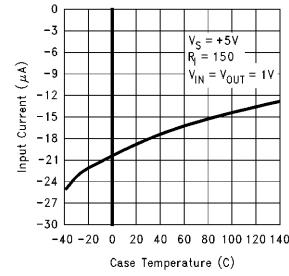

**LM7131 Input Current vs Input Voltage @ 3V**

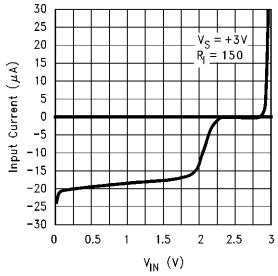

**LM7131 Input Current vs Input Voltage @ 5V**

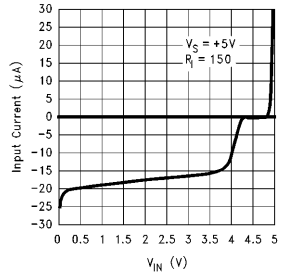

**LM7131 CMRR vs Frequency @ 5V**

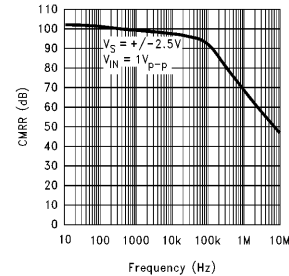

**LM7131 Voltage Noise vs Frequency @ 3V**

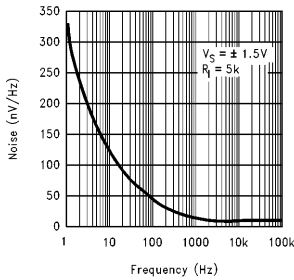

**LM7131 Voltage Noise vs Frequency @ 5V**

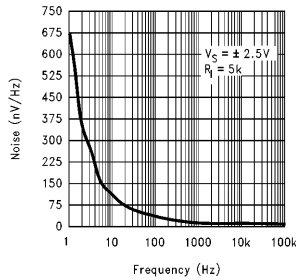

**LM7131 PSRR vs Frequency @ 3V**

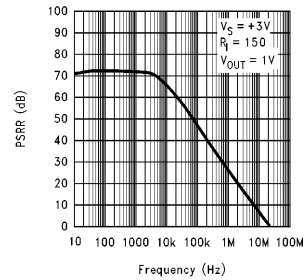

**LM7131 PSRR vs Frequency @ 5V**

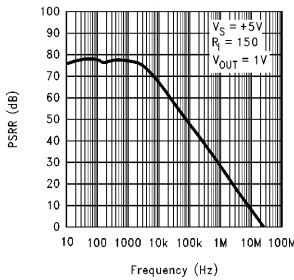

**LM7131 Cable Driver AV = +1 @ +3V**

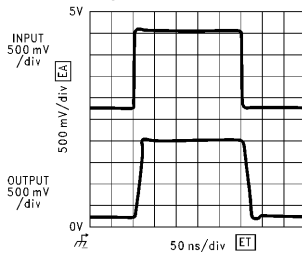

**LM7131 Cable Driver AV = +2 @ +3V**

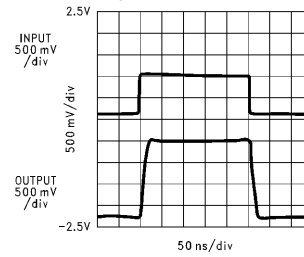

## Typical Performance Characteristics (Continued)

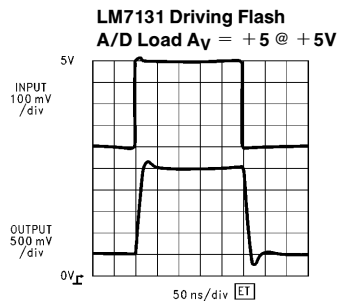
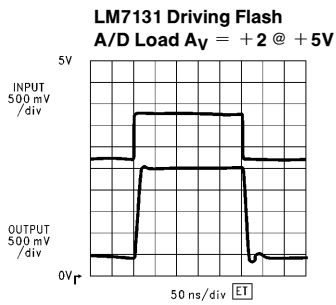
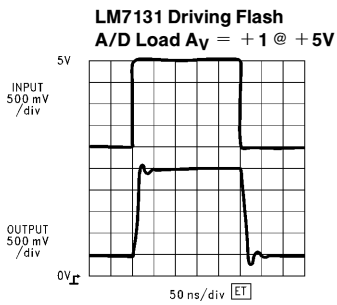
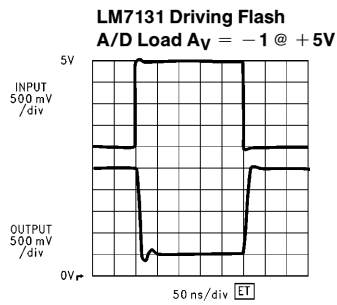
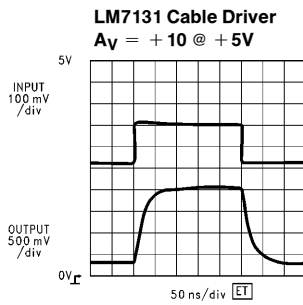
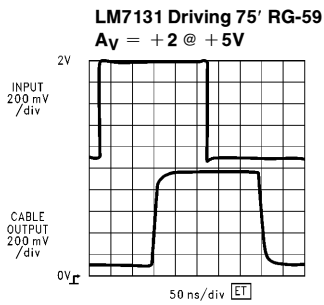
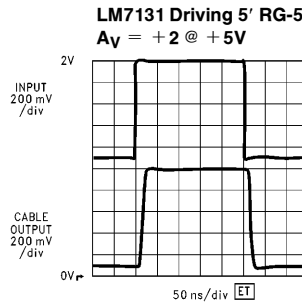
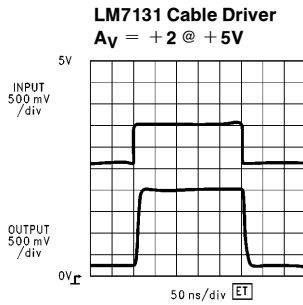
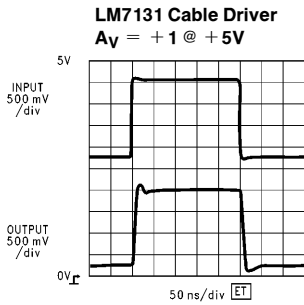
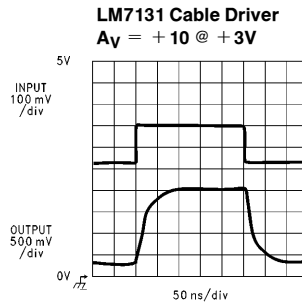
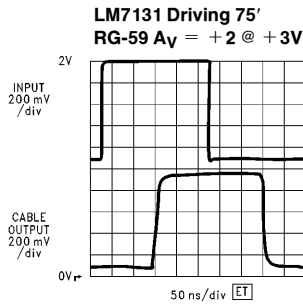
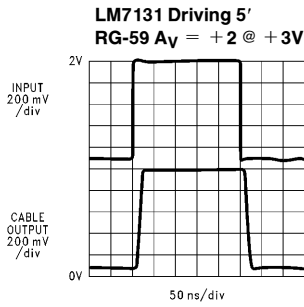

TL/H/12313-4



## Typical Performance Characteristics (Continued)

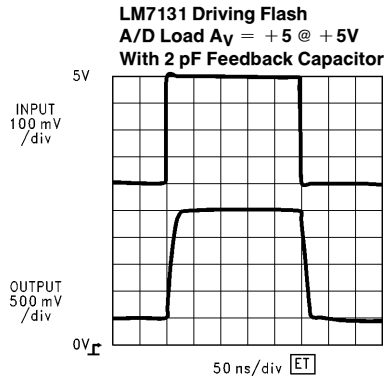

TL/H/12313-5

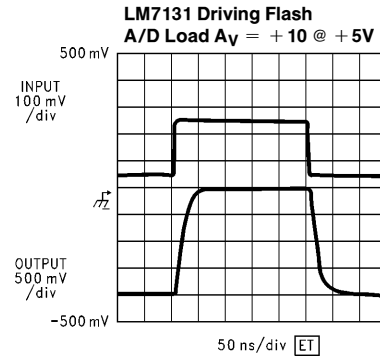

TL/H/12313-6

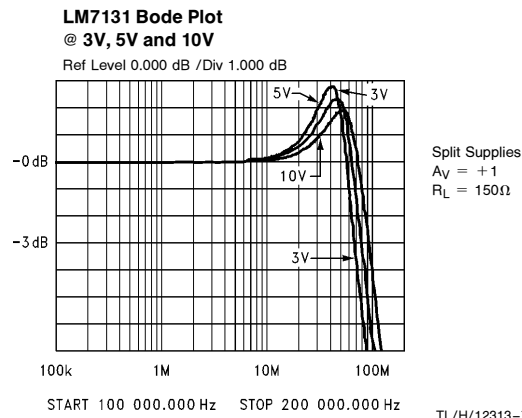

TL/H/12313-7

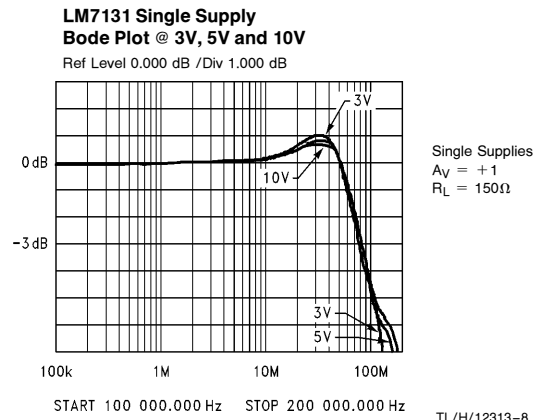

TL/H/12313-8

## Application Information

### GENERAL INFORMATION

The LM7131 is a high speed complementary bipolar amplifier which provides high performance at single supply voltages. The LM7131 will operate at  $\pm 5V$  split supplies,  $+5V$  single supplies, and  $+3V$  single supplies. It can provide improved performance for  $\pm 5V$  designs with an easy transition to  $+5V$  single supply. The LM7131 is a voltage feedback amplifier which can be used in most operational amplifier circuits.

The LM7131 is available in three package types: DIPs for through hole designs, SO-8 surface mount packages and the SOT23-5 Tiny package for space and weight savings.

The LM7131 has been designed to meet some of the most demanding requirements for single supply amplifiers—driving analog to digital converters and video cable driving. The output stage of the LM7131 has been specially designed for the dynamic load presented by analog to digital converters. The LM7131 is capable of a 4V output range with a  $+5V$  single supply. The LM7131's drive capability and good differential gain and phase make quality video possible from a small package with only a  $+5V$  supply.

### BENEFITS OF THE LM7131

The LM7131 can make it possible to amplify high speed signals with a single  $+5V$  or  $+3V$  supply, saving the cost of split power supplies.

### EASY DESIGN PATH FROM $\pm 5V$ to $+5V$ SYSTEMS

The DIP and SO-8 packages and similar  $\pm 5V$  and single supply specifications means the LM7131 may be able to replace many more expensive or slower op amps, and then be used for an easy transition to 5V single supply systems. This could provide a migration path to lower voltages for the amplifiers in system designs, reducing the effort and expense of testing and re-qualifying different op amps for each new design.

In addition to providing a design migration path, the three packages types have other advantages.

The DIPs can be used for easy prototyping and through hole boards. The SO-8 for surface mount board designs, and using the SOT23-5 for a smaller surface mount package can save valuable board space.

### SPECIFIC ADVANTAGES OF SOT23-5 (TINY PACKAGE)

The SOT23-5 (Tiny) package can save board space and allow tighter layouts. The low profile can help height limited designs, such as sub-notebook computers, consumer video equipment, personal digital assistants, and some of the thicker PCMCIA cards. The small size can improve signal integrity in noisy environments by placing the amplifier closer to the signal source. The tiny amp can fit into tight spaces and weighs little. This makes it possible to design the LM7131 into places where amplifiers could not previously fit.

The LM7131 can be used to drive coils and transformers referenced to virtual ground, such as magnetic tape heads

and disk drive write heads. The small size of the SOT23-5 package can allow it to be placed with a pre-amp inside of some rotating helical scan video head (VCR) assemblies. This avoids long cable runs for low level video signals, and can result in higher signal fidelity.

Additional space savings parts are available in tiny packages from National Semiconductor, including low power amplifiers, precision voltage references, and voltage regulators.

## Notes on Performance Curves and Datasheet Limits

### Important:

Performance curves represent an average of parts, and are not limits.

### SUPPLY CURRENT vs SUPPLY VOLTAGE

Note that this curve is nearly straight, and rises slowly as the supply voltage increases.

### INPUT CURRENT vs INPUT VOLTAGE

This curve is relatively flat in the 200 mV to 4V input range, where the LM7131 also has good common mode rejection.

### COMMON MODE VOLTAGE REJECTION

Note that there are two parts to the CMRR specification of the datasheet for 3V and 5V. The common mode rejection ratio of the LM7131 has been maximized for signals near ground (typical of the active part of video signals, such as those which meet the RS-170 levels). This can help provide rejection of unwanted noise pick-up by cables when a balanced input is used with good input resistor matching. The mid-level CMRR is similar to that of other single supply op amps.

### BODE PLOTS (GAIN vs FREQUENCY FOR $A_V = +1$ )

The gain vs. frequency plots for a non-inverting gain of 1 show the three voltages with the  $150\Omega$  load connected in two ways. For the single supply graphs, the load is connected to the most negative rail, which is ground. For the split supply graphs, the load is connected to a voltage halfway between the two supply rails.

### DRIVING CABLES

Pulse response curves for driving  $75\Omega$  back terminate cables are shown for both 3V and 5V supplies. Note the good pulse fidelity with straight 150 loads, five foot (1.5 meter) and 75 foot (22 meter) cable runs. The bandwidth is reduced when used in a gain of ten ( $A_V = +10$ ). Even in a gain of ten configuration, the output settles to  $< 1\%$  in about 100 ns, making this useful for amplifying small signals at a sensor or signal source and driving a cable to the main electronics section which may be located away from the signal source. This will reduce noise pickup.

Please refer to *Figures 1-5* for schematics of test setups for cable driving.

## Application Information (Continued)

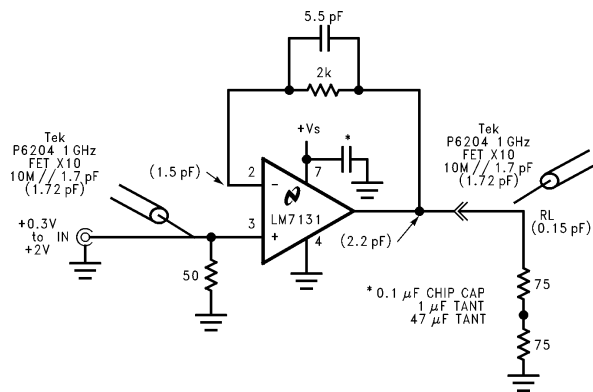

TL/H/12313-9

Numbers in parentheses are measured fixture capacitances w/o DUT and load.

**FIGURE 1. Cable Driver  $A_V = +1$**

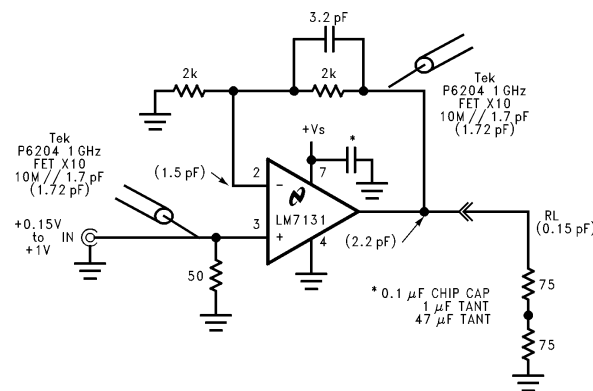

TL/H/12313-10

Numbers in parentheses are measured fixture capacitances w/o DUT and load.

**FIGURE 2. Cable Driver  $A_V = +2$**

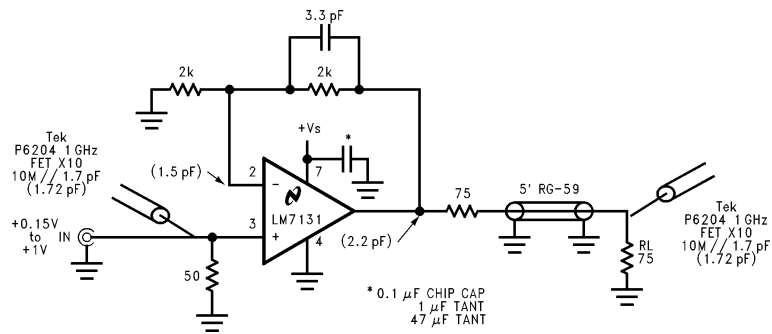

TL/H/12313-11

Numbers in parentheses are measured fixture capacitances w/o DUT and load.

**FIGURE 3. Cable Driver 5' RG-59**

## Application Information (Continued)

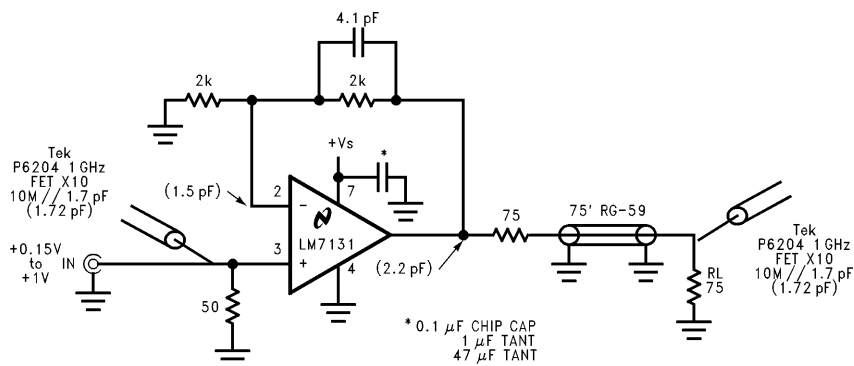

Numbers in parentheses are measured fixture capacitances w/o DUT and load.

TL/H/12313-12

**FIGURE 4. Cable Driver 75' RG-59**

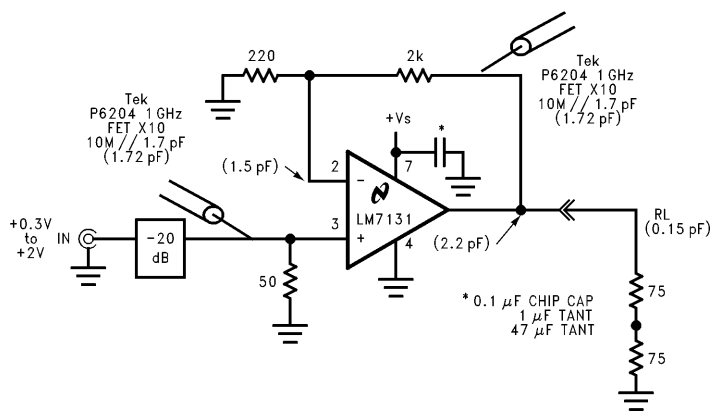

Numbers in parentheses are measured fixture capacitances w/o DUT and load.

TL/H/12313-13

**FIGURE 5. Cable Driver Gain of 10  $A_V = +10$**

## Application Information (Continued)

### DRIVING TYPE 1175 FLASH A/D LOADS

The circuits in *Figures 6–11* show a LM7131 in a voltage follower configuration driving the passive equivalent of a typical flash A/D input. Note that there is a slight ringing on the output, which can affect accurate analog-to-digital conversion. In these graphs, we have adjusted the ringing to be a little larger than desirable in order to better show the settling time. Most settling times at low gain are about 75 ns to < 1% of final voltage. The ringing can be reduced by adding a low value (approximately 500Ω) feedback resistor from the output to the inverting input and placing a small (picofar-

ad range) capacitor across the feedback resistor. See *Figures 9 and 10* for schematics and respective performance curves for flash A/D driving at  $A_V = +5$  with and without a 2 pF feedback capacitor.

See section on feedback compensation. Ringing can also be reduced by placing an isolation resistor between the output and the analog-to-digital converter input—see sections on driving capacitive loads and analog-to-digital converters.

Please refer to *Figures 6–11* for schematics of test setups for driving flash A/D converters.

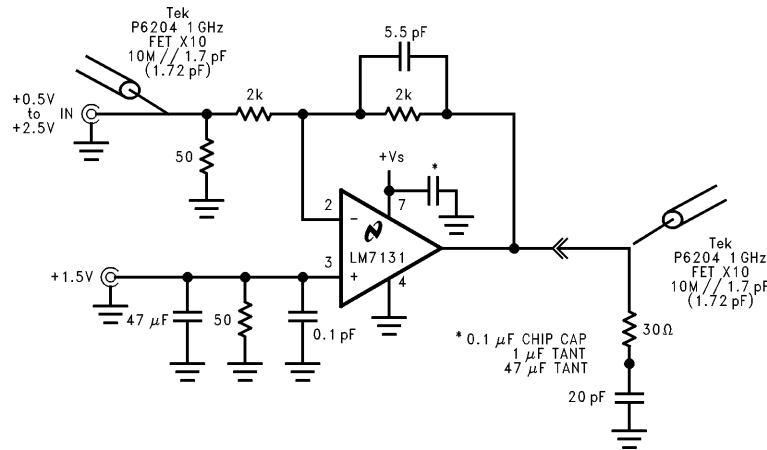

Numbers in parentheses are measured fixture capacitances w/o DUT and load.

TL/H/12313-14

FIGURE 6. Flash A/D  $A_V = -1$

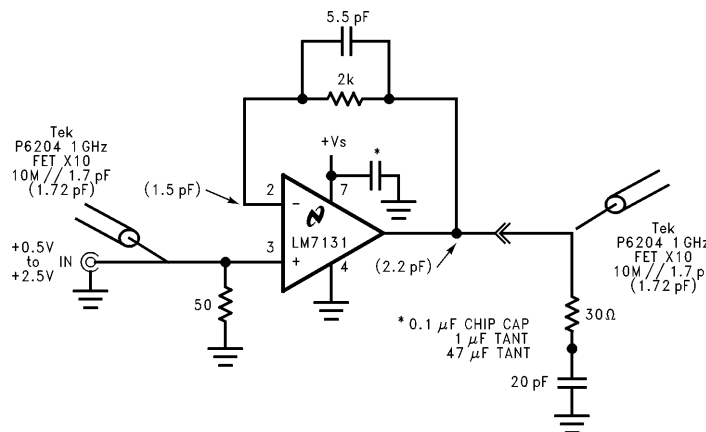

Numbers in parentheses are measured fixture capacitances w/o DUT and load.

TL/H/12313-15

FIGURE 7. Flash A/D  $A_V = +1$

## Application Information (Continued)

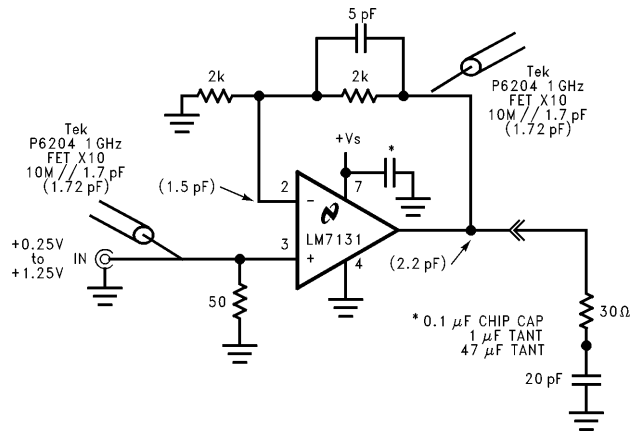

TL/H/12313-16

Numbers in parentheses are measured fixture capacitances w/o DUT and load.

**FIGURE 8. Flash A/D  $A_v = +2$**

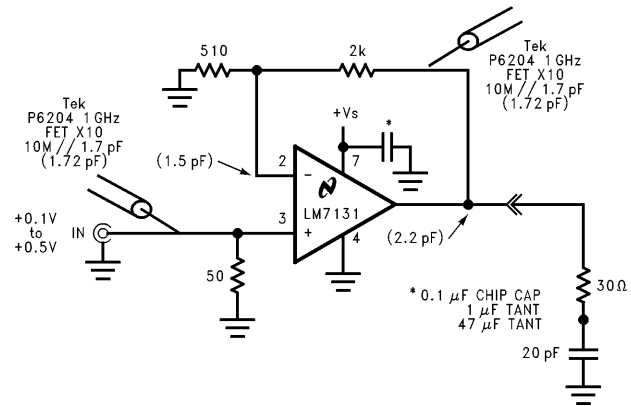

TL/H/12313-17

Numbers in parentheses are measured fixture capacitances w/o DUT and load.

**FIGURE 9. Flash A/D  $A_v = +5$**

## Application Information (Continued)

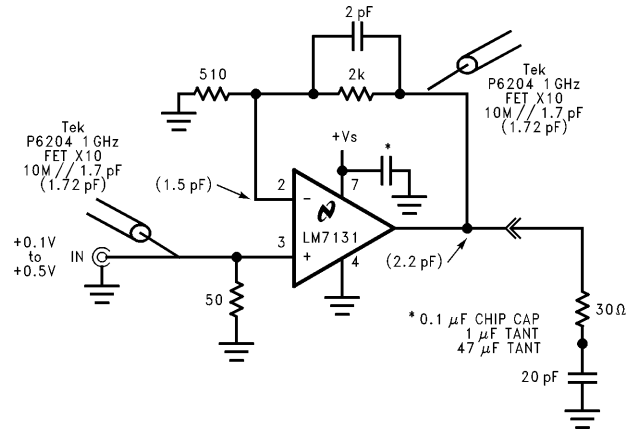

TL/H/12313-18

Numbers in parentheses are measured fixture capacitances w/o DUT and load.

**FIGURE 10. Flash A/D  $A_v = +5$  with Feedback Capacitor**

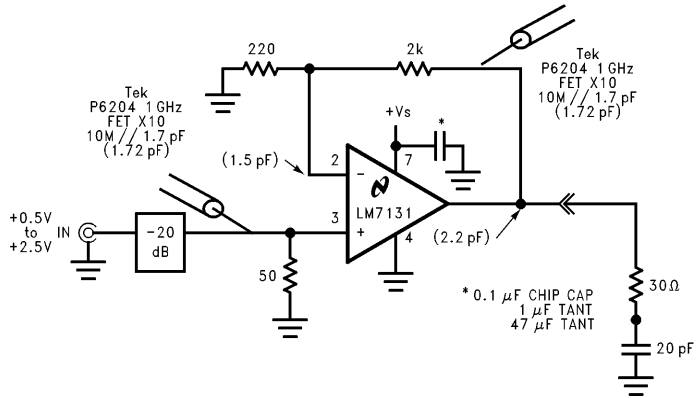

TL/H/12313-19

Numbers in parentheses are measured fixture capacitances w/o DUT and load.

**FIGURE 11. Flash A/D  $A_v = +10$**

## Using the LM7131

### LIMITS AND PRECAUTIONS

#### Supply Voltage

The absolute maximum supply voltage which may be applied to the LM7131 is 12V. Designers should not design for more than 10V nominal, and carefully check supply tolerances under all conditions so that the voltages do not exceed the maximum.

#### Differential Input Voltage

Differential input voltage is the difference in voltage between the non-inverting (+) input and the inverting input (-) of the op amp. The absolute maximum differential input voltage is  $\pm 2V$  across the inputs. This limit also applies when there is no power supplied to the op amp. This may not be a problem in most conventional op amp designs, however, designers should avoid using the LM7131 as comparator or forcing the inputs to different voltages. In some designs, diode protection may be needed between the inputs. See Figure 12.

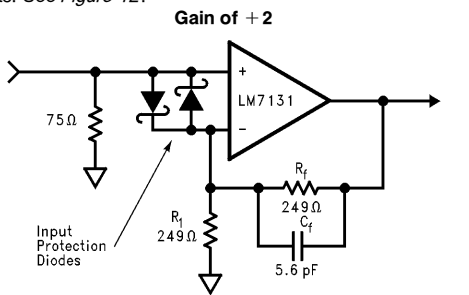

FIGURE 12

TL/H/12313-20

#### Output Short Circuits

The LM7131 has output short circuit protection, however, it is not designed to withstand continuous short circuits, very fast high energy transient voltage or current spikes, or shorts to any voltage beyond the power supply rails. Designs should reduce the number and energy level of any possible output shorts, especially when used with  $\pm 5V$  supplies.

A resistor in series with the output, such as the 75 $\Omega$  resistor used to back terminate 75 $\Omega$  cables, will reduce the effects of shorts. For outputs which will send signals off the PC board additional protection devices, such as diodes to the power rails, zener-type surge suppressors, and varistors may be useful.

#### Thermal Management

Note that the SOT23-5 (Tiny) package has less power dissipation capability (325 $^{\circ}/W$ ) than the S0-8 and DIP packages (115 $^{\circ}/W$ ). This may cause overheating with  $\pm 5$  supplies and heavy loads at high ambient temps. This is less of a problem when using +5V single supplies.

Example:

Driving a 150 $\Omega$  load to 2.0V at a 40 $^{\circ}C$  (104  $^{\circ}F$ ) ambient temperature. (This is common external maximum temperature for office environments. Temperatures inside equipment may be higher.)

No load power-

No load LM7131 supply current - 9.0 mA

Supply voltage is 5.0V

No load LM7131 power - 9.0 mA x 5.0V = 45 mW

Power with load-

Current out is 2.0V/150  $\Omega$  = 13.33 mA

Voltage drop in LM7131 is 5.0V (supply) - 2.0V (output) = 3.0V

Power dissipation 13.33 mA x 3.0V = 40 mW

Total Power = 45 mW + 40 mW = 85 mW = 0.085

Temperature Rise = 0.085 W x 325 $^{\circ}/W$  = 27.625 degrees

Junction temperature at 40 $^{\circ}$  ambient = 40 + 27.625 = 67.6225 $^{\circ}$ .

This device is within the 0 $^{\circ}$  to 70 $^{\circ}$  specification limits.

The 325 $^{\circ}/W$  value is based on still air and the pc board land pattern shown in this datasheet. Actual power dissipation is sensitive to PC board connections and airflow.

SOT23-5 power dissipation may be increased by airflow or by increasing the metal connected to the pads, especially the center pin (pin number 2, V-) on the left side of the SOT23-5. This pin forms the mounting paddle for the die inside the SOT23-5, and can be used to conduct heat away from the die. The land pad for pin 2 can be made larger and/or connected to power planes in a multilayer board.

Additionally, it should be noted that difficulty in meeting performance specifications for the LM7131 is most common at cold temperatures. While excessively high junction temperatures will degrade LM7131 performance, testing has confirmed that most specifications are met at a junction temperature of 85 $^{\circ}C$ .

See "Understanding Integrated Circuit Package Power Capabilities", Application Note AN-336, which may be found in the appendix of the Operational Amplifier Databook.

#### Layout and Power Supply Bypassing

Since the LM7131 is a high speed (over 50 MHz) device, good high speed circuit layout practices should be followed. This should include the use of ground planes, adequate power supply bypassing, removing metal from around the input pins to reduce capacitance, and careful routing of the output signal lines to keep them away from the input pins.

The power supply pins should be bypassed on both the negative and positive supply inputs with capacitors placed close to the pins. Surface mount capacitors should be used for best performance, and should be placed as close to the pins as possible. It is generally advisable to use two capacitors at each supply voltage pin. A small surface mount capacitor with a value of around 0.01 microfarad (10 nF), usually a ceramic type with good RF performance, should be placed closest to the pin. A larger capacitor, in usually in the range of 1.0  $\mu F$  to 4.7  $\mu F$ , should also be placed near the pin. The larger capacitor should be a device with good RF characteristics and low ESR (equivalent series resistance) for best results. Ceramic and tantalum capacitors generally work well as the larger capacitor.

For single supply operation, if continuous low impedance ground planes are available, it may be possible to use bypass capacitors between the +5V supply and ground only, and reduce or eliminate the bypass capacitors on the V- pin.



## Using the LM7131 (Continued)

### Capacitive Load Driving

The phase margin of the LM7131 is reduced by driving large capacitive loads. This can result in ringing and slower settling of pulse signals. This ringing can be reduced by placing a small value resistor (typically in the range of  $22\Omega$ – $100\Omega$ ) between the LM7131 output and the load. This resistor should be placed as close as practical to the LM7131 output. When driving cables, a resistor with the same value as the characteristic impedance of the cable may be used to isolate the cable capacitance from the output. This resistor will reduce reflections on the cable.

### Input Current

The LM7131 has typical input bias currents in the  $15\ \mu\text{A}$  to  $25\ \mu\text{A}$  range. This will not present a problem with the low input impedances frequently used in high frequency and video circuits. For a typical  $75\Omega$  input termination,  $20\ \mu\text{A}$  of input current will produce a voltage across the termination resistor of only  $1.5\ \text{mV}$ . An input impedance of  $10\ \text{k}\Omega$ , however, would produce a voltage of  $200\ \text{mV}$ , which may be large compared to the signal of interest. Using lower input impedances is recommended to reduce this error source.

### Feedback Resistor Values and Feedback Compensation

Using large values of feedback resistances (roughly  $2\text{k}$ ) with low gains (such gains of 2) will result in degraded pulse response and ringing. The large resistance will form a pole with the input capacitance of the inverting input, delaying feedback to the amplifier. This will produce overshoot and ringing. To avoid this, the gain setting resistors should be scaled to lower values (below  $1\text{k}$ ) At higher gains ( $> 5$ ) larger values of feedback resistors can be used.

Overshoot and ringing of the LM7131 can be reduced by adding a small compensation capacitor across the feedback resistor. For the LM7131 values in pF to tens of pF range are useful initial values. Too large a value will reduce the circuit bandwidth and degrade pulse response.

Since the small stray capacitance from the circuit layout, other components, and specific circuit bandwidth requirements will vary, it is often useful to select final values based on prototypes which are similar in layout to the production circuit boards.

### Reflections

The output slew rate of the LM7131 is fast enough to produce reflected signals in many cables and long circuit traces. For best pulse performance, it may be necessary to terminate cables and long circuit traces with their characteristic impedance to reduce reflected signals.

Reflections should not be confused with overshoot. Reflections will depend on cable length, while overshoot will depend on load and feedback resistance and capacitance. When determining the type of problem, often removing or drastically shortening the cable will reduce or eliminate reflections. Overshoot can exist without a cable attached to the op amp output.

### Driving Flash A/D Converters (Video Converters)

The LM7131 has been optimized to drive flash analog to digital converters in a  $+5\text{V}$  only system. Different flash A/D converters have different voltage input ranges. The LM7131 has enough gain-bandwidth product to amplify standard video level signals to voltages which match the optimum input range of many types of A/D converters.

For example, the popular 1175 type 8-bit flash A/D converter has a preferred input range from  $0.6\text{V}$  to  $2.6\text{V}$ . If the input signal has an active video range (excluding sync levels) of approximately  $700\ \text{mV}$ , a circuit like the one in *Figure 13* can be used to amplify and drive an A/D. The  $10\ \mu\text{F}$  capacitor blocks the DC components, and allows the  $+$  input of the LM7131 to be biased through R clamp so that the minimum output is equal to  $V_{\text{RB}}$  of the A/D converter. The gain of the circuit is determined as follows:

$$\text{Output Signal Range} = 2.6\text{V (V top)} - 0.6\text{V (V bottom)} = 2.0\text{V}$$

$$\text{Gain} = \text{Output Signal Range}/\text{Input Signal} = 2.857 = 2.00/0.700$$

$$\text{Gain} = (R_f/R_1) + 1 = (249\Omega/133\Omega) + 1$$

R isolation and  $C_f$  will be determined by the designer based on the A/D input capacitance and the desired pulse response of the system. The nominal values of  $33\Omega$  and  $5.6\ \text{pF}$  shown in the schematic may be a useful starting point, however, signal levels, A/D converters, and system performance requirements will require modification of these values.

The isolation resistor, R isolation should be placed close to the output of the LM7131, which should be close to the A/D input for best results.

R clamp is connected to a voltage level which will result in the bottom of the video signal matching the  $V_{\text{rb}}$  level of the A/D converter. This level will need to be set by clamping the black level of the video signal. The clamp voltage will depend on the level and polarity of the video signal. Detecting the sync signal can be done by a circuit such as the LM1881 Video Sync Separator.

**Important Note:** This is an illustration of a conceptual use of the LM7131, not a complete design. The circuit designer will need to modify this for input protection, sync, and possibly some type of gain control for varying signal levels.

Some A/D converters have wide input ranges where the lower reference level can be adjusted. With these converters, best distortion results are obtained if the lower end of the output range is about  $250\ \text{mV}$  or more above the  $V-$  input of the LM7131 more. The upper limit can be as high as  $4.0\text{V}$  with good results.

### Driving the ADC12062 +5V 12-BIT A/D Converter

*Figure 14* shows the LM7131 driving a National ADC12062 12 bit analog to digital converter. Both devices can be powered from a single  $+5\text{V}$  supply, lowering system complexity and cost. With the lowest signal voltage limited to  $300\ \text{mV}$  and a  $3.8\text{V}$  peak-to-peak  $100\ \text{KHz}$  signal, bench tests have shown distortion less than  $-75\ \text{db}$ , signal to noise ratios greater than  $66\ \text{db}$ , and SINAD (signal to noise + distortion) values greater than  $65\ \text{db}$ . For information on the latest single supply analog-to-digital converters, please contact your National Semiconductor representative.

## Using the LM7131 (Continued)

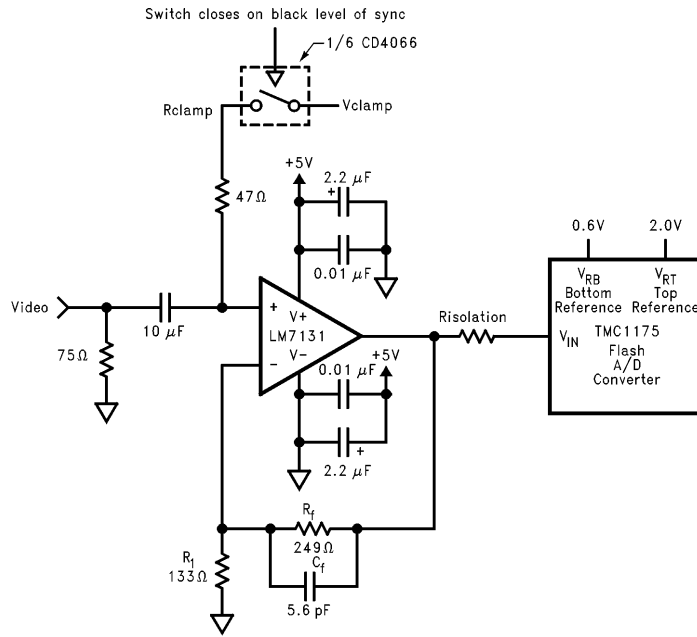

FIGURE 13

TL/H/12313-21

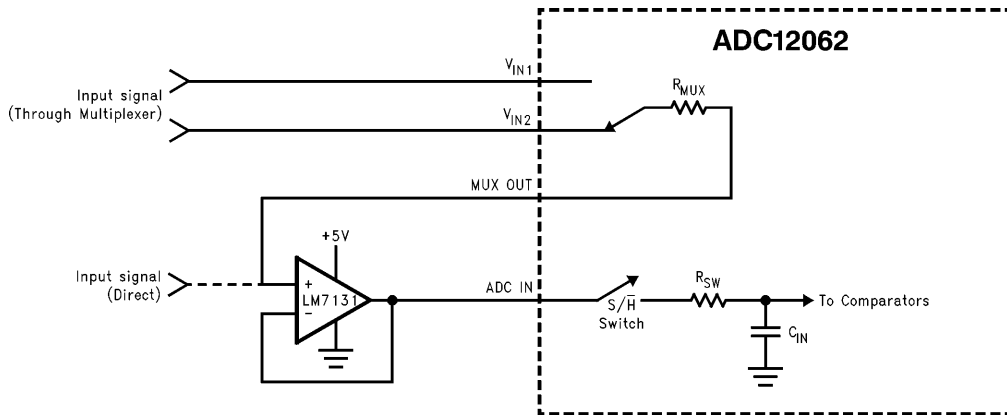

FIGURE 14. Buffering the Input with an LM7131 High Speed Op Amp

TL/H/12313-22

## Using the LM7131 (Continued)

### CCD Amplifiers

The LM7131 has enough gain bandwidth to amplify low level signals from a CCD or similar image sensor and drive a flash analog-to-digital converter with one amplifier stage.

Signals from CCDs, which are used in scanners, copiers, and digital cameras, often have an output signal in the 100 mV–300 mV range. See *Figure 15* for a conceptual diagram. With a gain of 6 the output to the flash analog-to-digital converter is 1.8V, matching 90% of the converter's 2V input range. With a –3db bandwidth of 70 MHz for a gain of +1, the bandwidth at a gain of 6 will be 11.6 MHz. This 11.6 MHz bandwidth will result in a time constant of about 13.6 ns. This will allow the output to settle to 7 bits of accuracy within 4.9 time constants, or about 66 ns. Slewing time for a 1.8V step will be about 12 ns. The total slewing and settling time will be about 78 ns of the 150 ns pixel valid time. This will leave about 72 ns total for the flash converter signal acquisition time and tolerance for timing signals.

For scanners and copiers with moving scan bars, the SOT23-5 package is small enough to be placed next to the light sensor. The LM7131 can drive a cable to the main electronics section from the scan bar. This can reduce noise pickup by amplifying the signal before sending on the cable.

### A/D Reference Drivers

The LM7131's output and drive capability make it a good choice for driving analog-to-digital references which have suddenly changing loads. The small size of the SOT23-5 package allow the LM7131 to be placed very close to the A/D reference pin, maximizing response. The small size avoids the penalty of increased board space. Often the SOT23-5 package is small enough that it can fit in space used by the large capacitors previously attached to the A/D reference. By acting as a buffer for a reference voltage, noise pickup can be reduced and the accuracy may be increased.

For additional space savings, the LM4040 precision voltage reference is available in a tiny SOT23-3 package.

### Video Gain of +2

The design of the LM7131 has been optimized for gain of +2 video applications. Typical values for differential gain and phase are 0.25% differential gain and 0.75 degree differential phase. See *Figure 12*.

### Improving Video Performance

Differential gain and phase performance can be improved by keeping the active video portion of the signal above 300 mV. The sync signal can go below 300 mV without affecting the video quality. If it is possible to AC couple the signal and shift the output voltage slightly higher, much better video performance is possible. For a +5V single supply, an output range between 2.0V and 3.0V can have a differential gain of 0.07% and differential phase of 0.3 degree when driving a 150Ω load. For a +3V single supply, the output should be between 1.0V and 2.0V.

### Cable Driving with +5V Supplies

The LM7131 can easily drive a back-terminated 75Ω video cable (150Ω load) when powered by a +5V supply. See *Figures 2, 3 and 4*. This makes it a good choice for video output for portable equipment, personal digital devices, and desktop video applications.

The LM7131 can also supply +2.00V to a 50Ω load to ground, making it useful as driver in 50Ω systems such as portable test equipment.

### Cable Driving with +3V Supplies

The LM7131 can drive 150Ω to 2.00V when supplied by a 3V supply. This 3V performance means that the LM7131 is useful in battery powered video applications, such as camcorders, portable video mixers, still video cameras, and portable scanners.

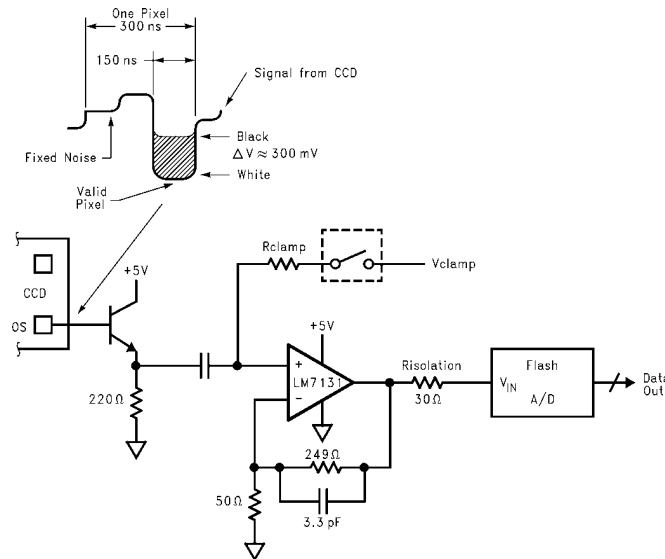

FIGURE 15. CCD Amplifier

TL/H/12313-23

## Using the LM7131 (Continued)

### Audio and High Frequency Signal Processing

The LM7131 is useful for high fidelity audio and signal processing. A typical LM7131 is capable of driving 2V across 150Ω (referenced to ground) at less than 0.1% distortion at 4 MHz when powered by a single 5V supply.

### Use with 2.5V Virtual Ground Systems with +5V Single Supply Power

Many analog systems which must work on a single +5V supply use a 'virtual ground' - a reference voltage for the signal processing which is usually between +5V and 0V. This virtual ground is usually halfway between the top and bottom supply rails. This is usually +2.5V for +5V systems and +1.5V for +3V systems.

The LM7131 can be used in single supply/virtual ground systems driving loads referenced to 2.5V. The output swing specifications in the data sheet show the tested voltage limits for driving a 150Ω load to a virtual ground supply for +3V and +5V. A look at the output swing specifications shows that for heavy loads like 150 ohms, the output will swing as close as one diode drop (roughly, 0.7V) to the supply rail. This leaves a relatively wide range for +5V systems and a somewhat narrow range for +3V systems. One way to increase this output range is to have the output load referenced to ground—this will allow the output to swing lower. Another is to use higher load impedances. The output swing specifications show typical numbers for swing with loads of 600Ω to ground. Note that these typical numbers are similar to those for a 150Ω load. These typical numbers are an indication of the maximum DC performance of the LM7131.

The sinking output of the LM7131 is somewhat lower than the amplifier's sourcing capability. This means that the LM7131 will not drive as much current into a load tied to 2.5 V as it will drive into a load tied to 0V.

Good AC performance will require keeping the output further away from the supply rails. For a +5V supply and relatively high impedance load (analog-to-digital converter input) the following are suggested as an initial starting range for achieving high (> 60 dB) AC accuracy

Upper output level—

Approximately 0.8V to 1V below the positive (V+) rail.

Lower output level—

Approximately 200 mV–300 mV above the negative rail.

The LM7131 very useful in virtual ground systems as an output device for output loads which are referenced to 0V or the lower rail. It is also useful as a driver for capacitive loads, such as sample and hold circuits, and audio analog to digital converters. If fast amplifiers with rail-to-rail output ranges are needed, please see the National Semiconductor LM6142 datasheet.

### D/A Output Amplifier

The LM7131 can be used as an output amplifier for fast digital-to-analog converters. When using the LM7131 with converters with an output voltage range which may exceed the differential input voltage limit of ±2V, it may be necessary to add protection diodes to the inputs. See Figure 16. For high speed applications, it may be useful to consider low capacitance schottky diodes. Additional feedback capacitance may be needed to control ringing due to the additional input capacitance from the D/A and protection diodes. When used with current output D/As, the input bias currents may produce a DC offset in the output. This offset may be canceled by a resistor between the positive input and ground.

### Spice Macromodel

A SPICE macromodel of the LM7131 and many other National Semiconductor op amps is available at no charge from your National Semiconductor representative.

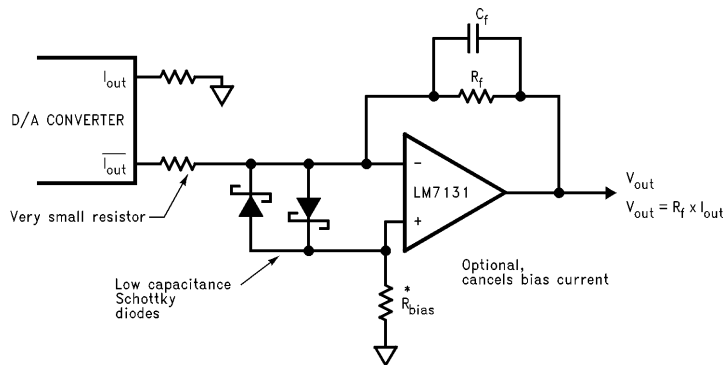

FIGURE 16. D/A Output Amplifier

TL/H/12313-24

# SOT-23-5 Tape and Reel Specification

## TAPE FORMAT

Tape Section	# Cavaties	Cavity Status	Cover Tape Status
Leader (Start End)	0 (min)	Empty	Sealed
	75 (min)	Empty	Sealed
Carrier	3000	Filled	Sealed
	250	Filled	Sealed
Trailer (Hub End)	125 (min)	Empty	Sealed
	0 (min)	Empty	Sealed

## TAPE DIMENSIONS

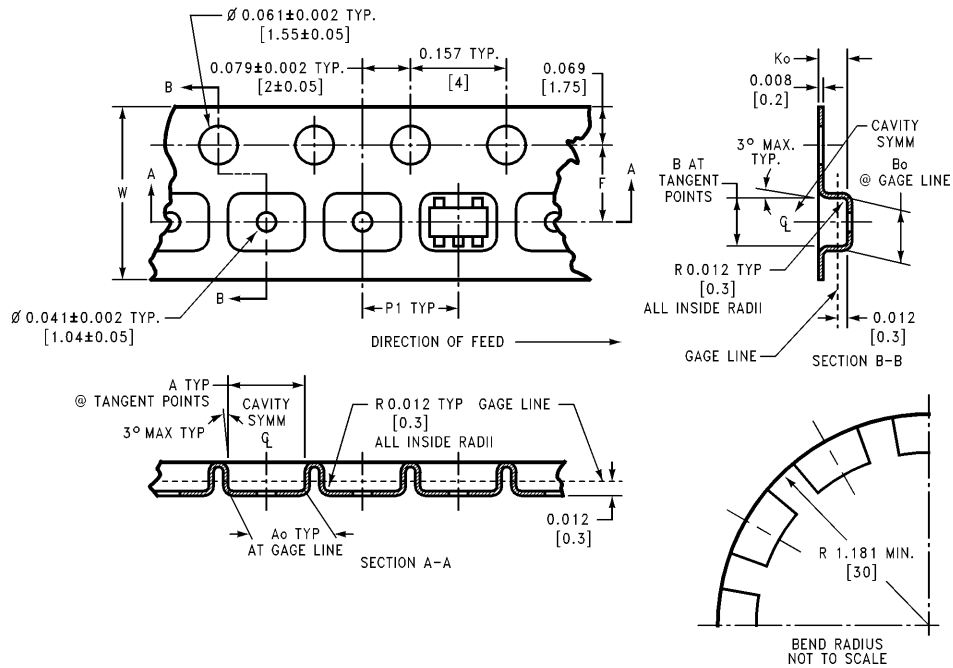

TL/H/12313-25

<b>8 mm</b>	<b>0.130</b> (3.3)	<b>0.124</b> (3.15)	<b>0.130</b> (3.3)	<b>0.126</b> (3.2)	<b>0.138 ± 0.002</b> (3.5 ± 0.05)	<b>0.055 ± 0.004</b> (1.4 ± 0.11)	<b>0.157</b> (4)	<b>0.315 ± 0.012</b> (8 ± 0.3)
Tape Size	DIM A	DIM Ao	DIM B	DIM Bo	DIM F	DIM Ko	DIM P1	DIM W

# SOT-23-5 Tape and Reel Specification (Continued)

## REEL DIMENSIONS

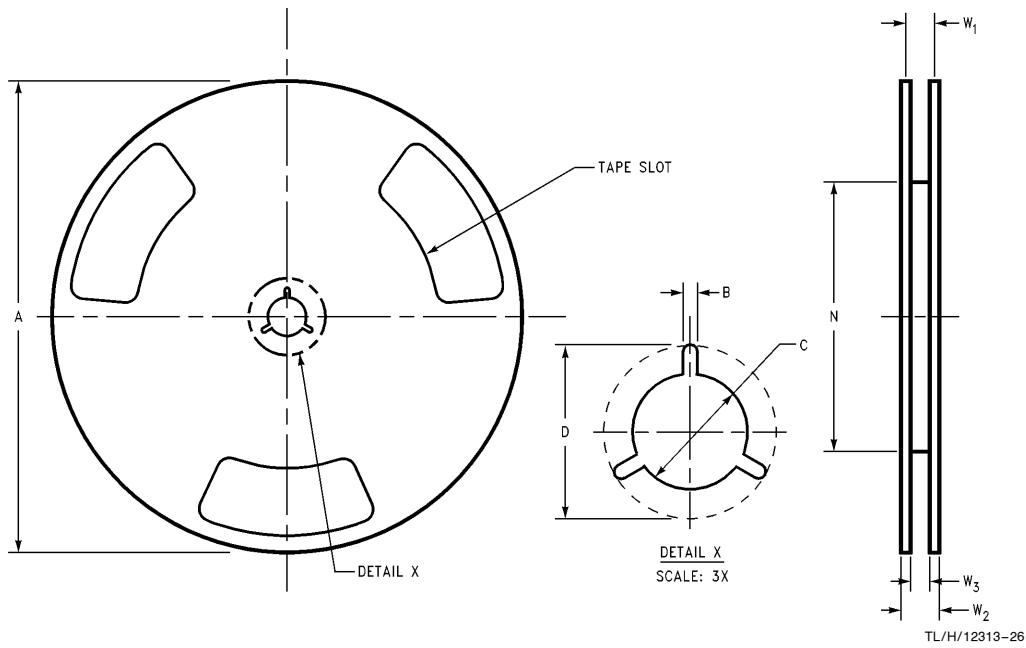

<b>8 mm</b>	<b>7.00</b>	<b>0.059</b>	<b>0.512</b>	<b>0.795</b>	<b>2.165</b>	<b>0.331 + 0.059 / - 0.000</b>	<b>0.567</b>	<b>W1 + 0.078 / - 0.039</b>
	<b>330.00</b>	<b>1.50</b>	<b>13.00</b>	<b>20.20</b>	<b>55.00</b>	<b>8.4 + 1.50 / - 0.00</b>	<b>14.40</b>	<b>W1 + 2.00 / - 1.00</b>
Tape Size	A	B	C	D	N	W1	W2	W3

**Physical Dimensions** inches (millimeters)

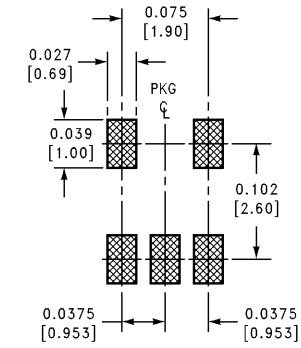
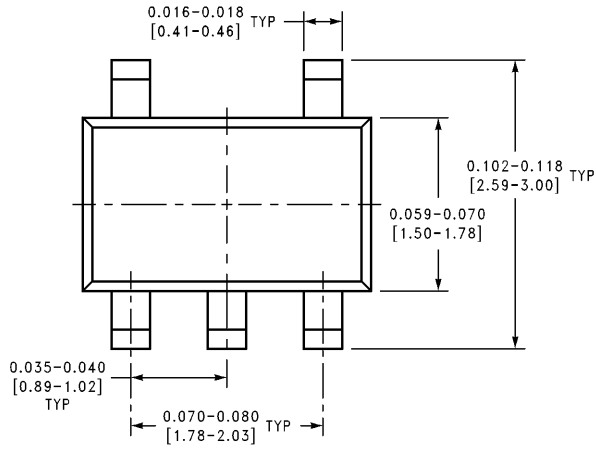

**LAND PATTERN RECOMMENDATION**

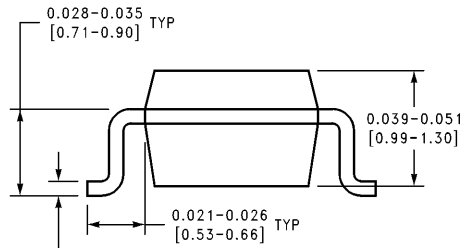
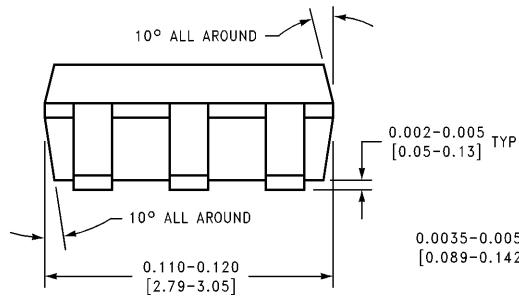

MA05A (REV D)

**5-Pin SOT Package**  
**Order Package Number LM7131ACM5\* or LM7131BCM5\***  
**NS Package Number MA05A**

**Physical Dimensions** inches (millimeters) (Continued)

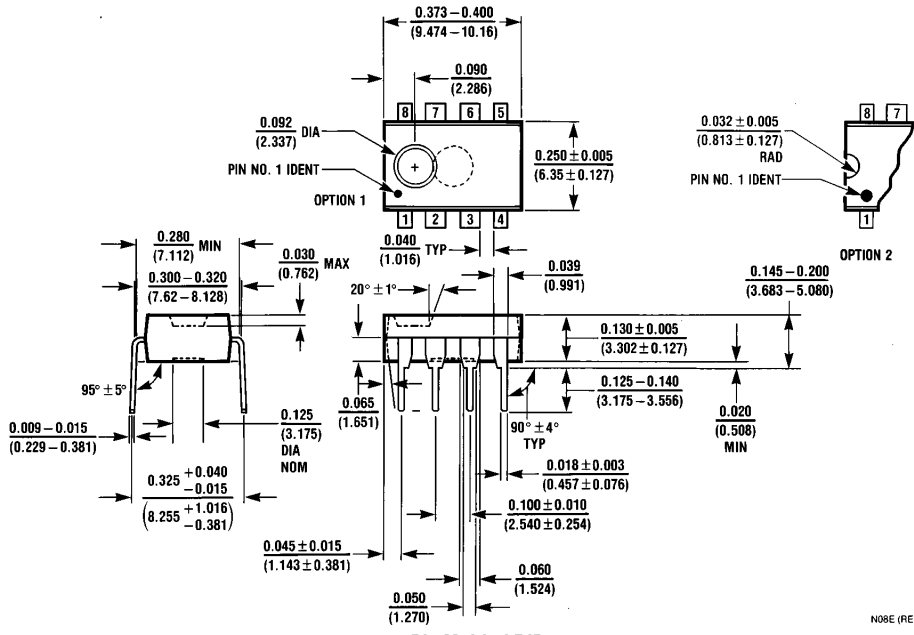

**8-Pin Molded DIP**  
**8-Lead (0.300" Wide) Molded Dual-In-Line Package**  
**Order Package Number LM7131ACN or LM7131BCN**  
**NS Package Number N08E**

N08E (REV F)

**LIFE SUPPORT POLICY**

NATIONAL'S PRODUCTS ARE NOT AUTHORIZED FOR USE AS CRITICAL COMPONENTS IN LIFE SUPPORT DEVICES OR SYSTEMS WITHOUT THE EXPRESS WRITTEN APPROVAL OF THE PRESIDENT OF NATIONAL SEMICONDUCTOR CORPORATION. As used herein:

1. Life support devices or systems are devices or systems which, (a) are intended for surgical implant into the body, or (b) support or sustain life, and whose failure to perform, when properly used in accordance with instructions for use provided in the labeling, can be reasonably expected to result in a significant injury to the user.
2. A critical component is any component of a life support device or system whose failure to perform can be reasonably expected to cause the failure of the life support device or system, or to affect its safety or effectiveness.



**National Semiconductor Corporation**  
 2900 Semiconductor Drive  
 P.O. Box 58090  
 Santa Clara, CA 95052-8090  
 Tel: 1(800) 272-9959  
 TWX: (910) 339-9240

**National Semiconductor GmbH**  
 Livny-Gargan-Str. 10  
 D-82256 Fürstenfeldbruck  
 Germany  
 Tel: (81-41) 35-0  
 Telex: 527549  
 Fax: (81-41) 35-1

**National Semiconductor Japan Ltd.**  
 Sumitomo Chemical  
 Engineering Center  
 Bldg. 7F  
 1-7-1, Nakase, Mihama-Ku  
 Chiba-City,  
 Ciba Prefecture 261  
 Tel: (043) 299-2300  
 Fax: (043) 299-2500

**National Semiconductor Hong Kong Ltd.**  
 13th Floor, Straight Block,  
 Ocean Centre, 5 Canton Rd.  
 Tsimshatsui, Kowloon  
 Hong Kong  
 Tel: (852) 2737-1600  
 Fax: (852) 2736-9960

**National Semicondutores Do Brazil Ltda.**  
 Rue Deputado Lacorda Franco  
 120-3A  
 Sao Paulo-SP  
 Brazil 05418-000  
 Tel: (55-11) 212-5066  
 Telex: 391-1131931 NSBR BR  
 Fax: (55-11) 212-1181

**National Semiconductor (Australia) Pty. Ltd.**  
 Building 16  
 Business Park Drive  
 Monash Business Park  
 Nottinghill, Melbourne  
 Victoria 3168 Australia  
 Tel: (3) 558-9999  
 Fax: (3) 558-9998

National does not assume any responsibility for use of any circuitry described, no circuit patent licenses are implied and National reserves the right at any time without notice to change said circuitry and specifications.