

LMS1585AEP/LMS1587EP

Enhanced Plastic 5A and 3A Low Dropout Fast Response Regulators

General Description

The LMS1585AEP and LMS1587EP are low dropout positive regulators with output load current of 5A and 3A respectively. Their low dropout voltage (1.2V) and fast transient response make them an excellent solution for low voltage microprocessor applications.

The LMS1585AEP/87EP are available in adjustable versions, which can set the output voltage with only two external resistors. In addition, they are also available in 1.5V and 3.3V fixed voltage versions (Note 12).

The LMS1585AEP/87EP circuits include a zener trimmed bandgap reference, current limiting and thermal shutdown.

The LMS1585AEP/87EP series are available in TO-220 and TO-263 packages.

ENHANCED PLASTIC

- Extended Temperature Performance of -40°C to 125°C
- Baseline Control - Single Fab & Assembly Site
- Process Change Notification (PCN)
- Qualification & Reliability Data
- Solder (PbSn) Lead Finish is standard
- Enhanced Diminishing Manufacturing Sources (DMS) Support

Features

- Fast transient response
- Available in Adjustable, 1.5V, and 3.3V versions
- Current limiting and thermal protection
- Line regulation 0.005% (typical)
- Load regulation 0.05% (typical)

Applications

- Low voltage logic supplies
- Selected Military Applications
- Selected Avionics Applications

Ordering Information

PART NUMBER	VID PART NUMBER	NS PACKAGE NUMBER (Note 3)
LMS1585AIS33EP	V62/04639-01	TS3B
LMS1585AISADJEP	V62/04639-02	TS3B
LMS1587ISXADJEP	V62/04639-03	TS3B
(Notes 1, 2)	TBD	TBD

Note 1: For the following (Enhanced Plastic) version, check for availability: LMS1585ACT3.3EP, LMS1585ACTADJEP, LMS1585AIT1.5EP, LMS1585AIT3.3EP, LMS1585AITADJEP, LMS1585ACS1.5EP, LMS1585ACS3.3EP, LMS1585ACSADJEP, LMS1585AIS1.5EP, LMS1585ACSX33EP, LMS1585CSXADJEP, LMS1585AISX15EP, LMS1585AISX33EP, LMS1585ASXADJEP, LMS1587CT1.5EP, LMS1587CT3.3EP, LMS1587CTADJEP, LMS1587IT1.5EP, LMS1587IT3.3EP, LMS1587ITADJEP, LMS1587CS1.5EP, LMS1587CS3.3EP, LMS1587CSADJEP, LMS1587IS1.5EP, LMS1587IS3.3EP, LMS1587ISADJEP, LMS1587CSX3.3EP, LMS1587CSXADJEP, LMS1587ISX1.5EP, LMS1587ISX3.3EP. Parts listed with an "X" are provided in Tape & Reel and parts without an "X" are in Rails.

Note 2: FOR ADDITIONAL ORDERING AND PRODUCT INFORMATION, PLEASE VISIT THE ENHANCED PLASTIC WEB SITE AT: www.national.com/mil

Note 3: Refer to package details under Physical Dimensions

Typical Application

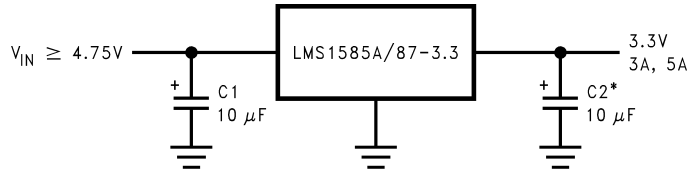

* REQUIRED FOR STABILITY

20099801

Connection Diagrams

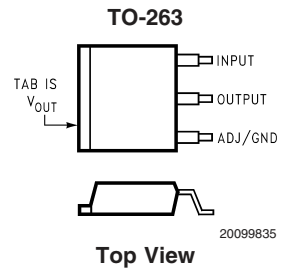
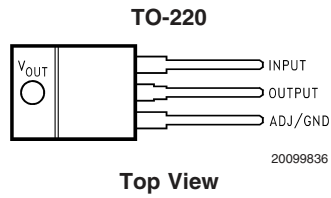

Simplified Schematic

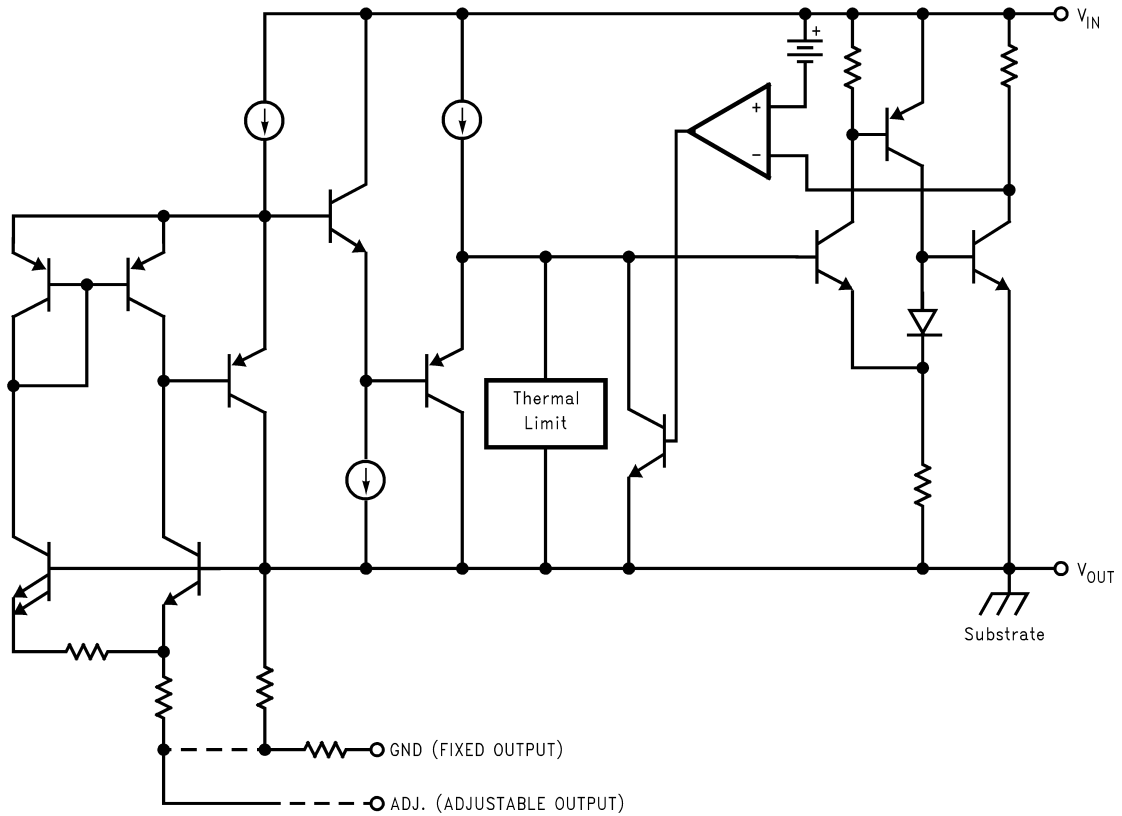

20099814

Absolute Maximum Ratings (Note 4)

If Military/Aerospace specified devices are required, please contact the National Semiconductor Sales Office/Distributors for availability and specifications.

Maximum Input to Output Voltage
(V_{IN} to GND) 13V

Power Dissipation (Note 5) Internally Limited
Junction Temperature (T_J) (Note 5) 150°C
Storage Temperature Range -65°C to 150°C
Lead Temperature 260°C, 10 sec
ESD Tolerance (Note 6) 2000V

Electrical Characteristics

Typicals and limits appearing in normal type apply for $T_J = 25^\circ\text{C}$. Limits appearing in **Boldface** type apply over the entire junction temperature range for operation, 0°C to 125°C for commercial grade and -40°C to 125°C for Enhanced Plastic.

Symbol	Parameter	Conditions	Min (Note 8)	Typ (Note 7)	Max (Note 8)	Units
V_{REF}	Reference Voltage	LMS1585A-ADJEP $V_{IN}-V_{OUT} = 3V$, $I_{OUT} = 10mA$ $10mA \leq I_{OUT} \leq 5A$, $1.5V \leq V_{IN}-V_{OUT} \leq 5.75V$	1.238	1.25	1.262	V
			1.225	1.250	1.275	V
		LMS1587-ADJEP $10mA \leq I_{OUT} \leq 3A$, $1.5V \leq V_{IN}-V_{OUT} \leq 5.75V$	1.225	1.250	1.275	V
V_{OUT}	Output Voltage	LMS1585A-1.5EP $I_{OUT} = 0mA$, $V_{IN} = 5V$ $0 \leq I_{OUT} \leq 5A$, $3V \leq V_{IN} \leq 7V$	1.485	1.500	1.515	V
			1.470		1.530	V
		LMS1585A-3.3EP $I_{OUT} = 0mA$, $V_{IN} = 5V$ $0 \leq I_{OUT} \leq 5A$, $4.75V \leq V_{IN} \leq 7V$	3.267	3.300	3.333	V
			3.235	3.300	3.365	V
		LMS1587-1.5EP $V_{IN} = 5V$, $I_{OUT} = 0mA$, $T_J = 25^\circ\text{C}$ $0 \leq I_{OUT} \leq 3A$, $3V \leq V_{IN} \leq 7V$	1.485	1.500	1.515	V
			1.470	1.500	1.530	V
ΔV_{OUT}	Line Regulation (Note 9)	LMS1585AEP/87-ADJEP $I_{OUT} = 10mA$, $2.75V \leq V_{IN} \leq 7V$		0.005	0.2	%
		LMS1585AEP/87-3.3EP $I_{OUT} = 0mA$, $4.75V \leq V_{IN} \leq 7V$		0.005	0.2	%
		LMS1585AEP/87-1.5EP $I_{OUT} = 0mA$, $3V \leq V_{IN} \leq 7V$		0.005	0.2	%
ΔV_{OUT}	Load Regulation (Note 9)	LMS1585A-ADJEP $V_{IN}-V_{OUT} = 3V$, $10mA \leq I_{OUT} \leq 5A$		0.05	0.5	%
		LMS1585A-1.5EP/LMS1585A-3.3EP $V_{IN} = 5V$, $0 \leq I_{OUT} \leq 5A$		0.05	0.5	%
		LMS1587-ADJEP $V_{IN}-V_{OUT} = 3V$, $10mA \leq I_{OUT} \leq 3A$		0.05	0.5	%
		LMS1587-1.5EP/LMS1587-3.3EP $V_{IN} = 5V$, $0 \leq I_{OUT} \leq 3A$		0.05	0.5	%
				0.05	0.5	%
$V_{IN}-V_{OUT}$	Dropout Voltage	LMS1585A-ADJEP/LMS1587-ADJEP $\Delta V_{REF} = 1\%$, $I_{OUT} = 3A$		1.15	1.3	V
		LMS1585A-3.3EP/LMS1587-3.3EP/ LMS1585A-1.5EP/LMS1587-1.5EP $\Delta V_{OUT} = 1\%$, $I_{OUT} = 3A$		1.15	1.3	V
		LMS1585A-ADJEP $\Delta V_{REF} = 1\%$, $I_{OUT} = 5A$		1.2	1.4	V
		LMS1585A-1.5EP/LMS1585A-3.3EP $\Delta V_{OUT} = 1\%$, $I_{OUT} = 5A$		1.2	1.4	V
				1.2	1.4	V

Electrical Characteristics (Continued)

Typicals and limits appearing in normal type apply for $T_J = 25^\circ\text{C}$. Limits appearing in **Boldface** type apply over the entire junction temperature range for operation, 0°C to 125°C for commercial grade and -40°C to 125°C for Enhanced Plastic.

Symbol	Parameter	Conditions	Min (Note 8)	Typ (Note 7)	Max (Note 8)	Units
I_{LIMIT}	Current Limit	LMS1585A-ADJEP/LMS1585A-3.3EP/ LMS1585A-1.5EP $V_{IN}-V_{OUT} = 5.5\text{V}$	5.0	6.6		A
		LMS1587-ADJEP/LMS1587-3.3EP/ LMS1587-1.5EP $V_{IN}-V_{OUT} = 5.5\text{V}$	3.1	4.3		A
	Minimum Load Current (Note 10)	LMS1585AEP/87-ADJEP $1.5\text{V} \leq V_{IN}-V_{OUT} \leq 5.75\text{V}$		2.0	10.0	mA
	Quiescent Current	LMS1585A-3.3EP/LMS1587-3.3EP/ LMS1585A-1.5EP/LMS1587-1.5EP $V_{IN} = 5\text{V}$		7.0	13.0	mA
	Thermal Regulation	$T_A = 25^\circ\text{C}$, 30ms Pulse		0.003		%/W
	Ripple Rejection	LMS1585A-ADJEP $f_{RIPPLE} = 120\text{Hz}$, $V_{IN}-V_{OUT} = 3\text{V}$, $I_{OUT} = 5\text{A}$, $C_{OUT} = 25\mu\text{F}$ Tantalum		72		dB
		LMS1585A-1.5EP $f_{RIPPLE} = 120\text{Hz}$, $C_{OUT} = 25\mu\text{F}$ Tantalum, $I_{OUT} = 5\text{A}$, $V_{IN} = 4.5\text{V}$	60	72		dB
		LMS1585A-3.3EP $f_{RIPPLE} = 120\text{Hz}$, $C_{OUT} = 25\mu\text{F}$ Tantalum, $I_{OUT} = 5\text{A}$, $V_{IN} = 6.3\text{V}$		72		dB
		LMS1587-ADJEP $f_{RIPPLE} = 120\text{Hz}$, $V_{IN}-V_{OUT} = 3\text{V}$, $I_{OUT} = 3\text{A}$ $C_{OUT} = 25\mu\text{F}$ Tantalum		72		dB
		LMS1587-1.5EP $f_{RIPPLE} = 120\text{Hz}$, $C_{OUT} = 25\mu\text{F}$ Tantalum, $I_{OUT} = 3\text{A}$, $V_{IN} = 4.5\text{V}$	60	72		dB
		LMS1587-3.3EP $f_{RIPPLE} = 120\text{Hz}$, $C_{OUT} = 25\mu\text{F}$ Tantalum, $I_{OUT} = 3\text{A}$, $V_{IN} = 6.3\text{V}$		72		dB
		Adjust Pin Current			55	120
	Adjust Pin Current	$10\text{mA} \leq I_{OUT} \leq I_{FULLLOAD}$, $1.5\text{V} \leq V_{IN}-V_{OUT} \leq 5.75\text{V}$ (Note 11)		0.2		μA
	Temperature Stability			0.5		%
	Long Term Stability	$T_A = 125^\circ\text{C}$, 1000Hrs		0.03		%
	RMS Output Noise (% of V_{OUT})	$10\text{Hz} \leq f \leq 10\text{kHz}$		0.003		%
	Thermal Resistance Junction-to-Case	3-Lead TO-263: Control/Output Section			0.65/2.7	$^\circ\text{C}/\text{W}$
		3-Lead TO-220: Control/Output Section			0.65/2.7	$^\circ\text{C}/\text{W}$

Note 4: Absolute Maximum Ratings indicate limits beyond which damage to the device may occur. Operating Ratings indicate conditions for which the device is intended to be functional, but specific performance is not guaranteed. For guaranteed specifications and the test conditions, see the Electrical Characteristics.

Note 5: The maximum power dissipation is a function of $T_{J(max)}$, θ_{JA} , and T_A . The maximum allowable power dissipation at any ambient temperature is $P_D = (T_{J(max)} - T_A) / \theta_{JA}$. All numbers apply for packages soldered directly into a PC board.

Note 6: For testing purposes, ESD was applied using human body model, $1.5\text{k}\Omega$ in series with 100pF .

Note 7: Typical Values represent the most likely parametric norm.

Note 8: All limits are guaranteed by testing or statistical analysis.

Note 9: Load and line regulation are measured at constant junction temperature, and are guaranteed up to the maximum power dissipation of 30W . Power dissipation is determined by the input/output differential and the output current. Guaranteed maximum power dissipation will not be available over the full input/output range.

Note 10: The minimum output current required to maintain regulation.

Note 11: $I_{FULLLOAD}$ is 5A for LMS1585AEP and 3A for LMS1587EP.

Note 12: Consult factory for other fixed voltage options.

Application Note

Output Voltage

The adjustable version develops at 1.25V reference voltage, (V_{REF}), between the output and the adjust terminal. As shown in *Figure 1*, this voltage is applied across resistor R1 to generate a constant current I1. This constant current then flows through R2. The resulting voltage drop across R2 adds to the reference voltage to sets the desired output voltage.

The current I_{ADJ} from the adjustment terminal introduces an output error. But since it is small (120 μ A max), it becomes negligible when R1 is in the 100 Ω range.

For fixed voltage devices, R1 and R2 are integrated inside the devices.

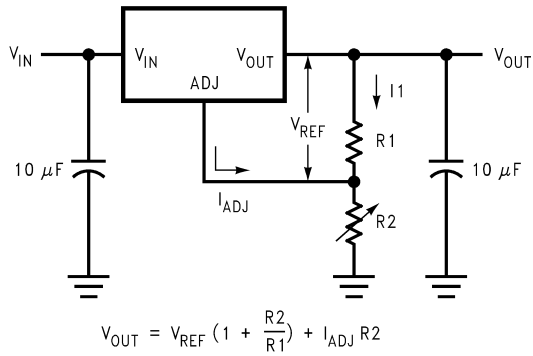

20099872

FIGURE 1. Basic Adjustable Regulator

Physical Dimensions inches (millimeters) unless otherwise noted (Continued)

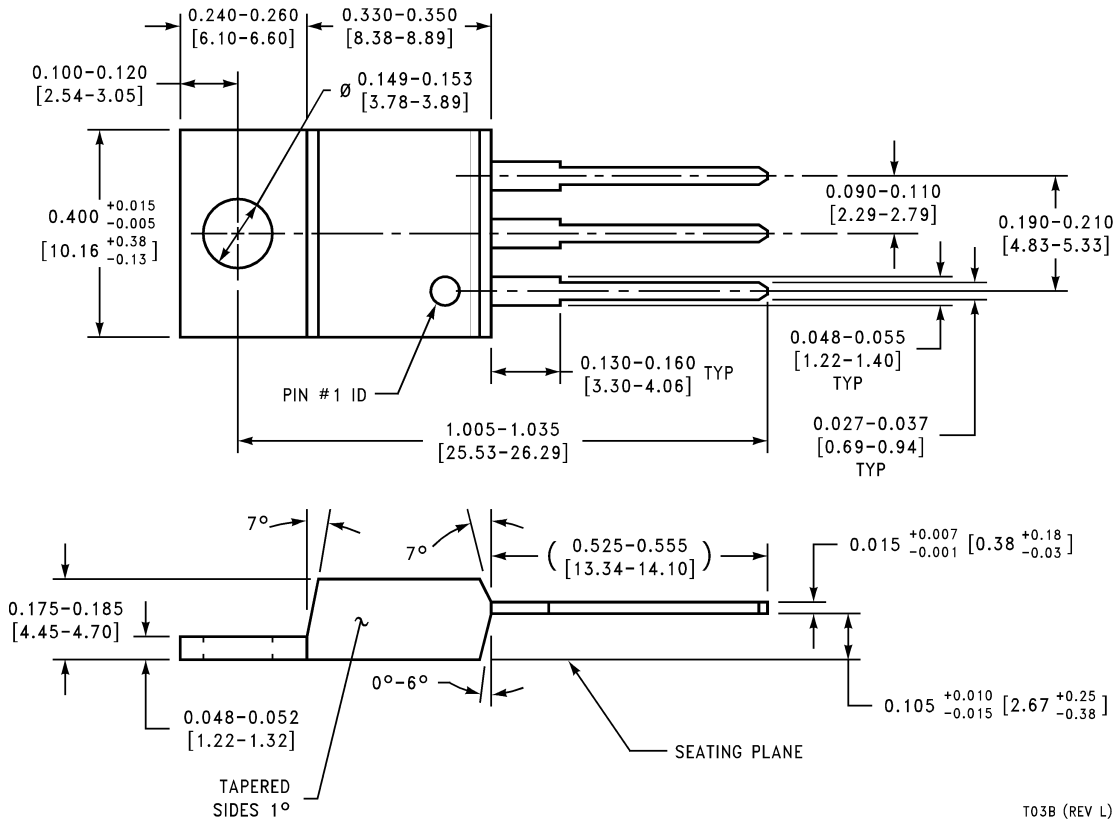

**3-Pin TO-220
NS Package Number T03B**

LIFE SUPPORT POLICY

NATIONAL'S PRODUCTS ARE NOT AUTHORIZED FOR USE AS CRITICAL COMPONENTS IN LIFE SUPPORT DEVICES OR SYSTEMS WITHOUT THE EXPRESS WRITTEN APPROVAL OF THE PRESIDENT AND GENERAL COUNSEL OF NATIONAL SEMICONDUCTOR CORPORATION. As used herein:

1. Life support devices or systems are devices or systems which, (a) are intended for surgical implant into the body, or (b) support or sustain life, and whose failure to perform when properly used in accordance with instructions for use provided in the labeling, can be reasonably expected to result in a significant injury to the user.
2. A critical component is any component of a life support device or system whose failure to perform can be reasonably expected to cause the failure of the life support device or system, or to affect its safety or effectiveness.

BANNED SUBSTANCE COMPLIANCE

National Semiconductor certifies that the products and packing materials meet the provisions of the Customer Products Stewardship Specification (CSP-9-111C2) and the Banned Substances and Materials of Interest Specification (CSP-9-111S2) and contain no "Banned Substances" as defined in CSP-9-111S2.



National Semiconductor
Americas Customer
Support Center
Email: new.feedback@nsc.com
Tel: 1-800-272-9959

National Semiconductor
Europe Customer Support Center
Fax: +49 (0) 180-530 85 86
Email: europe.support@nsc.com
Deutsch Tel: +49 (0) 69 9508 6208
English Tel: +44 (0) 870 24 0 2171
Français Tel: +33 (0) 1 41 91 8790

National Semiconductor
Asia Pacific Customer
Support Center
Email: ap.support@nsc.com

National Semiconductor
Japan Customer Support Center
Fax: 81-3-5639-7507
Email: jpn.feedback@nsc.com
Tel: 81-3-5639-7560

www.national.com