

LMS202E

15KV ESD Rated, 5V Single Supply TIA/EIA-232 Dual Transceivers

General Description

The LMS202E features two transmitters and two receivers for RS-232 communication. It has a DC-to-DC converter that permits the device to operate with only a single +5V power supply. The on-chip DC-to-DC converter which utilizes four external $0.1\mu\text{F}$ capacitors to generate dual internal power supplies for RS-232 compatible output levels.

The device meet EIA/TIA-232E and CCITT V.28 specifications up to 230kbits/sec. The LMS202E is available in a 16 pin narrow and wide SOIC package.

The transmitter outputs and receiver inputs have $\pm 15\text{kV}$ electrostatic discharge (ESD) protection. The LMS202E survives a $\pm 15\text{kV}$ ESD event to the RS-232 input and output pins when subjected according to Human Body Model or IEC 1000-4-2 (EN61000-4-2), air-gap specification. It survives a $\pm 8\text{kV}$ discharge when subjected to IEC 1000-4-2 (EN61000-4-2), contact specification. This device is designed for use in harsh environments where ESD is a concern.

Features

- ESD protection for RS-232 I/O pins
 - $\pm 15\text{kV}$ -IEC1000 4-2 (EN61000-4-2) Contact Discharge
 - $\pm 8\text{kV}$ -IEC1000 4-2 (EN61000-4-2) Air-Gap Discharge
 - $\pm 15\text{kV}$ Human Body Model
- Single +5V power supply
- 230 kbps data rate
- On-board DC-to-DC converter
- $0.1\mu\text{F}$ charge pump capacitors
- Drop-in replacement to Maxim's MAX202E

Applications

- POS equipment (Bar code reader)
- Hand-held equipment
- General purpose RS-232 communication

Connection Diagram and Typical Circuit

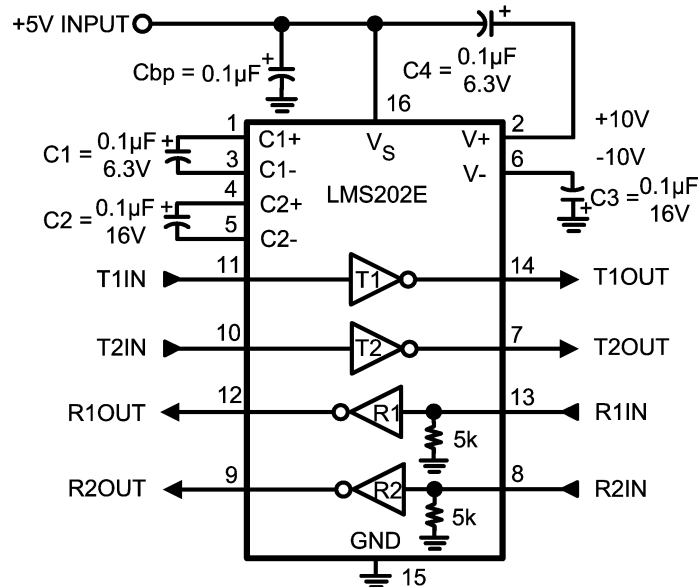

20048001

Pin Descriptions

Pin Number	Pin Name	Pin Function
1, 3	C1+, C1-	External capacitor connection pins. Recommended external capacitor C1 = 0.1 μ F (6.3V)
2	V+	Positive supply for TIA/EIA-232E drivers. Recommended external capacitor C4 = 0.1 μ F (6.3V)
4, 5	C2+, C2-	External capacitor connection pins. Recommended external capacitor C2 = 0.1 μ F (16V)
6	V-	Negative supply for TIA/EIA-232E drivers. Recommended external capacitor C3 = 0.1 μ F (16V)
7, 14	T1out, T2out	Transmitter output pins conform to TIA/EIA-232E levels. The typical transmitter output swing is \pm 8V when loaded 3k Ω load to ground. The open-circuit output voltage swings from (V+ - 0.6V) to V-
8,13	R1in, R2in	Receiver inputs accept TIA/EIA-232
9, 12	R1out and R2out	Receiver output pins are TTL/CMOS compatible
10, 11	Tin1, Tin2	Transmitter input pins are TTL/CMOS compatible. Inputs of transmitter do not have pull-up resistors. Connect all unused transmitter inputs to ground
15	GND	Ground pin
16	V _S	Power supply pin for the device, +5V (\pm 10%)

Ordering Information

Package	Part Number	Package Marking	Transport Media	NSC Drawing
16-Pin SOIC	LMS202ECM	LMS202ECM	48 Units/Rail	M16A
	LMS202ECMX		2.5k Units Tape and Reel	
	LMS202EIM	LMS202EIM	48 Units/Rail	
	LMS202EIMX		2.5k Units Tape and Reel	
16-Pin Wide SOIC	LMS202ECMW	LMS202ECMW	45 Units/Rail	M16B
	LMS202ECMWX		1.0k Units Tape and Reel	
	LMS202EIMW	LMS202EIMW	45 Units/Rail	
	LMS202EIMWX		1.0k Units Tape and Reel	

Absolute Maximum Ratings (Note 1)

If Military/Aerospace specified devices are required, please contact the National Semiconductor Sales Office/Distributors for availability and specifications.

V_S	-0.3V to 6V
V_+	$(V_S - 0.3V)$ to + 14V
V_-	+0.3V to -14V
Driver Input Voltage, T_{IN}	-0.3V to $(V_+ + 0.3V)$
Receiver Input Voltage, R_{IN}	$\pm 30V$
Driver Output Voltage T_O	$(V_- - 0.3V)$ to $(V_+ + 0.3V)$
Receiver Output Voltage R_O	-0.3 to $(V_S + 0.3)$
Short Circuit Duration, T_O	Continuous
ESD Rating	
IEC 1000-4-2) (Note 7)	
(Note 8)	
Air-Gap Discharge	15kV
Contact Discharge	8kV
Human Body Model (Note 2)	
(Note 8)	15kV

(Note 9)	2kV
ESD Rating (MM)	200V (Note 6) (Note 9)
Soldering Information	
Infrared or Convection	235°C
(20sec.)	
Junction Temperature	150°C
Storage Temperature Range	-65°C to +150°C

Operating Ratings

Supply Voltage V_S	4.5V to 5.5V
Ambient Temperature Range, T_A	
Commercial (C)	0°C to +70°C
Industrial (I)	-40°C to +85°C
Package Thermal Resistance	
(Note 3)	
SO	71°C/W
WSO	55°C/W

Electrical Characteristics

Over recommended operating supply and temperature ranges unless otherwise specified $C_1 = C_2 = C_3 = C_4 = C_{bp} = 0.1\mu F$

Symbol	Parameter	Conditions	Min (Note 5)	Typ	Max (Note 5)	Units
DC Characteristics						
I_S	Supply Current	No Load, $T_A = 25^\circ C$		1	7	mA
Logic						
I_{INPUT}	Input Leakage Current	$T_{IN} = 0V$ to V_S			± 10	μA
V_{THL}	Input Logic Theshold Low	T_{IN}			0.8	V
V_{THH}	Input Logic Theshold High	T_{IN}	2.0			V
V_{OL}	TTL/CMOS Output Voltage Low	$R_{OUT}, I_{OUT} = 3.2mA$			0.4	V
V_{OH}	TTL/CMOS Output Voltage High	$R_{OUT}, I_{OUT} = -1.0mA$	3.5	$V_S - 0.1$		V
RS-232 Receiver Inputs						
V_{RI}	Receiver Input Voltage Range		-30		+30	V
V_{RTHL}	Receiver Input Theshold Low	$V_S = 5V, T_A = 25^\circ C$	0.8	1.4		V
V_{RTHH}	Receiver Input Theshold High	$V_S = 5V, T_A = 25^\circ C$		2	2.4	V
V_{HYST}	Receiver Input Hysteresis	$V_S = 5V$	0.2	0.6	1.0	V
R_I	Receiver Input Resistance	$V_S = 5V, T_A = 25^\circ C$	3	5	7	k Ω
RS-232 Transmitter Outputs						
V_O	Transmitter Output Voltage Swing	All transmitters loaded with 3k Ω to GND	± 5	± 8		V
R_O	Output Resistance	$V_S = V_+ = V_- = 0V,$ $V_O = \pm 2V$	300			Ω
I_{OS}	Output Short Circuit Current			± 11	± 60	mA
Timing Characteristics						
DR	Maximum Data Rate	$C_L = 50pF$ to 1000pF, $R_L = 3k\Omega$ to 7k Ω	230			kbps

Electrical Characteristics (Continued)Over recommended operating supply and temperature ranges unless otherwise specified $C_1 = C_2 = C_3 = C_4 = C_{bp} = 0.1\mu\text{F}$

Symbol	Parameter	Conditions	Min (Note 5)	Typ	Max (Note 5)	Units
T_{RPLH} T_{RPHL}	Receiver Propagation Delay	$C_L = 150\text{pF}$		0.08	1	μs
T_{DPLH} T_{DPHL}	Transmitter Propagation Delay	$R_L = 3\text{k}\Omega$, $C_L = 2500\text{pF}$ All transmitters loaded		2.4		μs
V_{SLEW}	Transition Region Slew Rate	$T_A = 25^\circ\text{C}$, $V_S = 5\text{V}$ $C_L = 50\text{pF}$ to 1000pF , $R_L = 3\text{k}\Omega$ to $7\text{k}\Omega$ Measured from $+3\text{V}$ to -3V or vice versa	3	6	30	$\text{V}/\mu\text{s}$

ESD Performance: Transmitter Outputs and Receiver Inputs

ESD Rating	Model	Min	Typ	Max	Units
	Human Body Model		± 15		kV
	IEC 1000-4-2, Contact		± 8		
	IEC 1000-4-2, Air-gap		± 15		

Note 1: Absolute Maximum Ratings indicate limits beyond which damage to the device may occur. Operating Ratings indicate conditions for which the device is intended to be functional, but specific performance is not guaranteed. For guaranteed specifications and the test conditions, see the Electrical Characteristics.

Note 2: Human Body Model, $1.5\text{k}\Omega$ in series with 100pF

Note 3: The maximum power dissipation is a function of $T_{J(\text{MAX})}$, θ_{JA} , and T_A . The maximum allowable power dissipation at any ambient temperature is $P_D = (T_{J(\text{MAX})} - T_A) / \theta_{JA}$. All numbers apply for packages soldered directly onto a PC board.

Note 4: Typical Values represent the most likely parametric norm.

Note 5: All limits are guaranteed by testing or statistical analysis

Note 6: Machine model, 0Ω in series with 200pF

Note 7: IEC 1000-4-2, 330Ω in series with 150pF

Note 8: ESD rating applies to pins 7, 8, 13 and 14

Note 9: ESD rating applies to pins 1, 2, 3, 4, 5, 6, 9, 10, 11, 12, 15 and 16

Typical Characteristics

Transmitter Output High Voltage vs. Load Capacitance

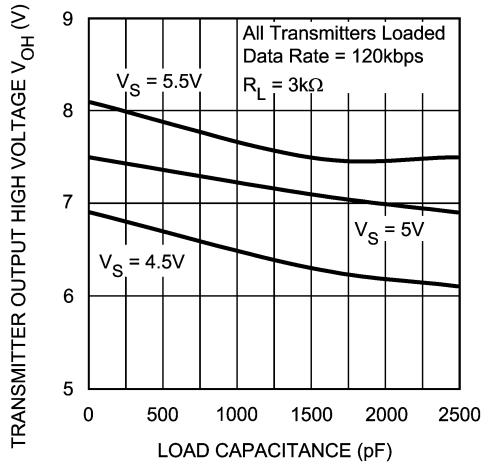

20048002

Transmitter Slew Rate vs. Load Capacitance

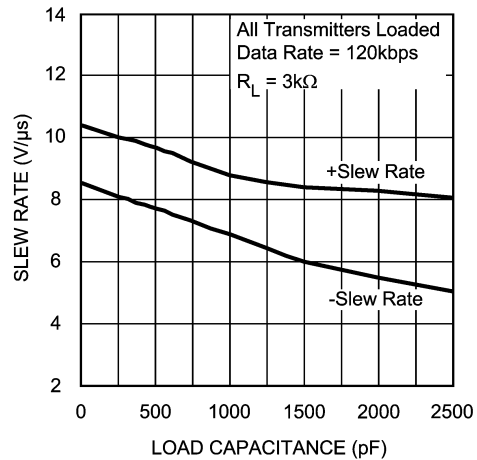

20048003

Application Information

CAPACITOR SELECTION

The recommended capacitors are 0.1μF. However, larger capacitors for the charge pump may be used to minimize ripples on V+ and V- pins.

POWER SUPPLY DECOUPLING

In some applications that are sensitive to power supply noise from the charge pump, place a decoupling capacitor, C_{bp}, from V_S to GND. Use at least a 0.1μF capacitor or the same size as the charge pump capacitors (C1 – C4).

CHARGED PUMP

The dual internal charged-pump provides the ±10V to the transmitters. Using capacitor C1, the charge pump converts +5V to +10V then stores the +10V in capacitor C3. The charge pump uses capacitor C2 to invert the +10V to -10V. The -10V is then stored in capacitor C4.

ELECTROSTATIC DISCHARGE PROTECTION

ESD protection has been placed at all pins to protect the device from ESD. All pins except for the transmitter output pins (pins 7 and 14) and receiver input pins (pins 8 and 13) have a 2kV Human Body Model (HBM) and 200V Machine Model (MM). The RS-232 bus pins (pins 7, 8, 13 and 14) have a more robust ESD protection. The RS-232 bus pins have a 15kV HBM and IEC 1000-4-2, air-gap. In addition, the bus pins meet an ESD rating of 8kV with IEC 1000-4-2, contact. The ESD structures can withstand a high ESD event under the following conditions: powered-on, powered-off, and Input connected to high and low with outputs unloaded.

HUMAN BODY MODEL

The Human Body Model is an ESD testing standard, defined in Mil-STD-883C method 3015.7. It simulates a human discharging an ESD charge to the IC device. The rise time is approximately 10 ns and decay time is approximately 150 ns. The waveform is obtained by discharging 2kV volts ca-

pacitor through a resistor, R2 = 1.5 kΩ. The peak current is approximately 1.33A.

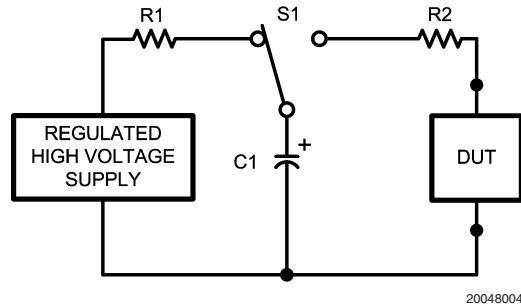

20048004

FIGURE 1. HBM ESD Test Model

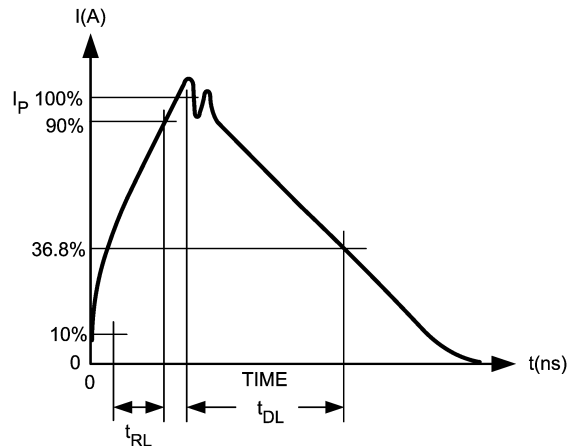

20048005

FIGURE 2. HBM Waveform

Application Information (Continued)

MACHINE MODEL

The Machine Model is the standard ESD test method in Japan and the automotive industry. It simulates a charge on large object discharging through the IC device. This takes place in automated test and handling systems. The equipment can accumulate static charge due to improper grounding, which is transmitted through the IC when it is picked and placed.

The waveform is obtained by discharging 400V volts capacitor to the device. Resistor, $R2 = 0\Omega$.

The parasitic inductance, L , from the PCB affects the peak current and period of the waveform. For $L = 0.5\mu\text{H}$, the peak current is approximately 7A with a period of 60 ns. For $L = 2.5\mu\text{H}$, the peak current is reduced to 4A with a period of 140 ns.

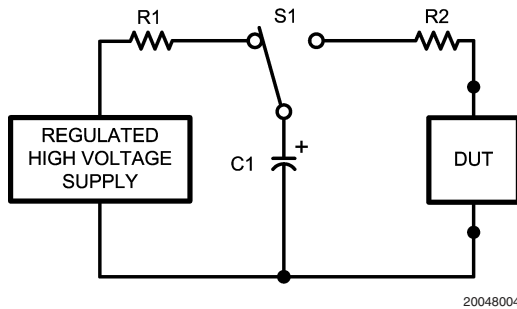

FIGURE 3. MM ESD Model

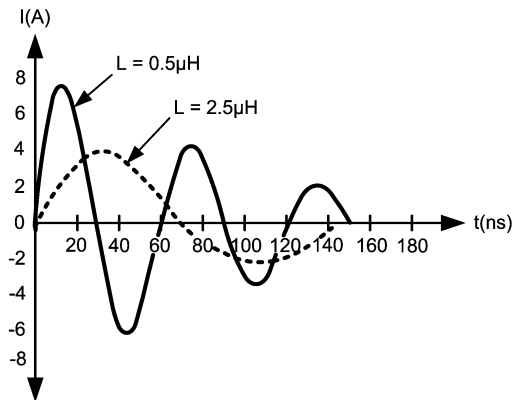

FIGURE 4. MM Waveform

IEC 1000-4-2 (EN61000-4-2)

The European Union requires ESD immunity testing for all electronic products as a condition for EMC Mark before shipping to any member countries. This is not a IC requirement but an overall system requirement. IEC 1000-4-2 specifies ESD testing both by contact and air-gap discharge. ESD testing by contact are generally more repeatable than air-gap but is less realistic to actual ESD event. However, air-gap discharge is more realistic but ESD results may vary widely dependent on environmental conditions (temperature, humidity,...) The waveform is obtained by discharging 150pF capacitor through a resistor, $R2 = 330\Omega$. A typical peak current may be high as 37A with 10kV.

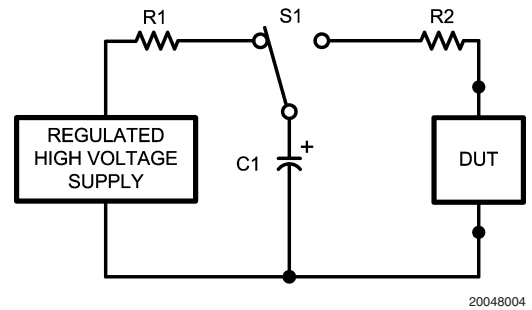

FIGURE 5. IEC ESD Model

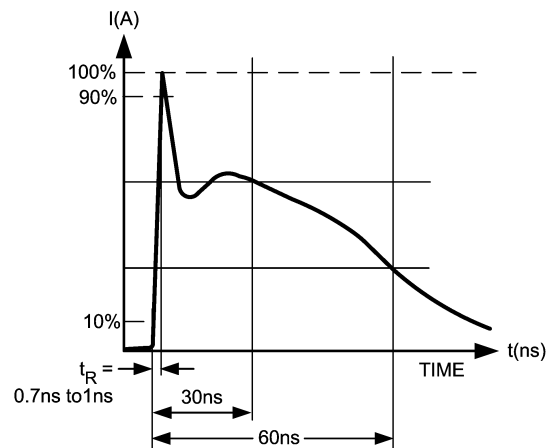
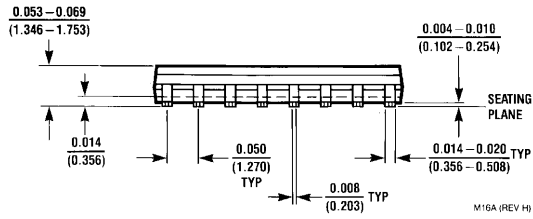
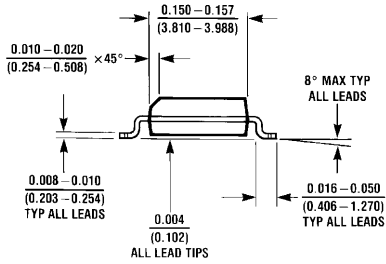
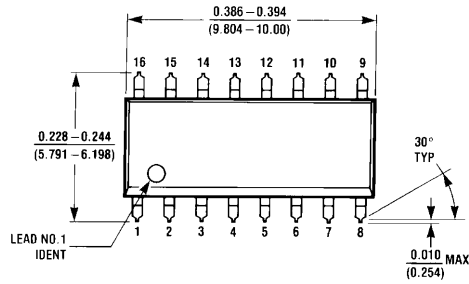
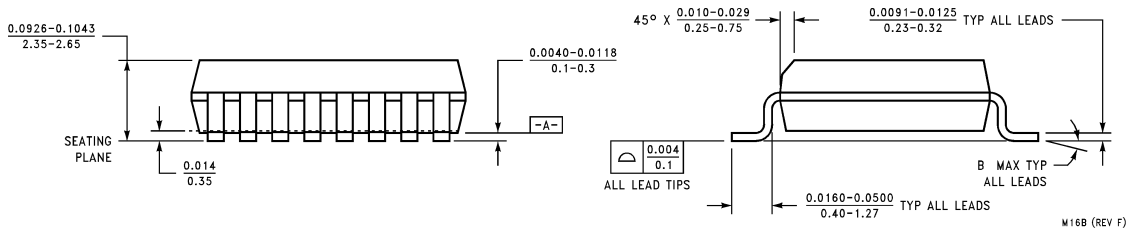
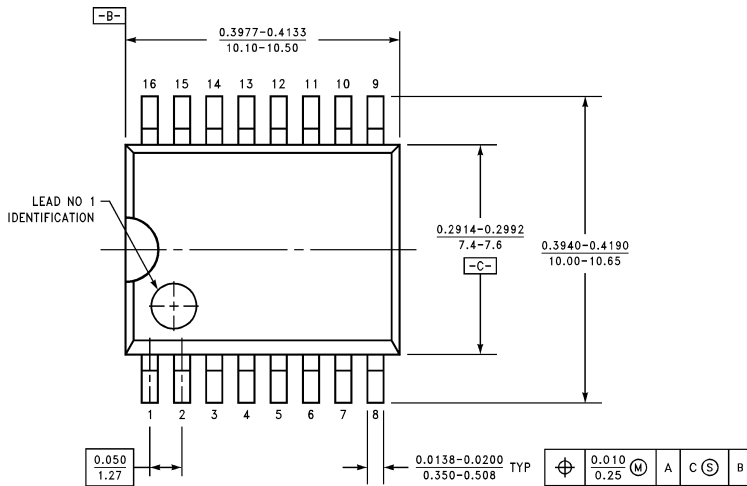

FIGURE 6. IEC Waveform

Physical Dimensions inches (millimeters) unless otherwise noted



16-Pin SOIC
NS Package Number M16A



16-Pin Wide SOIC
NS Package Number M16B

Notes

LIFE SUPPORT POLICY

NATIONAL'S PRODUCTS ARE NOT AUTHORIZED FOR USE AS CRITICAL COMPONENTS IN LIFE SUPPORT DEVICES OR SYSTEMS WITHOUT THE EXPRESS WRITTEN APPROVAL OF THE PRESIDENT AND GENERAL COUNSEL OF NATIONAL SEMICONDUCTOR CORPORATION. As used herein:

1. Life support devices or systems are devices or systems which, (a) are intended for surgical implant into the body, or (b) support or sustain life, and whose failure to perform when properly used in accordance with instructions for use provided in the labeling, can be reasonably expected to result in a significant injury to the user.
2. A critical component is any component of a life support device or system whose failure to perform can be reasonably expected to cause the failure of the life support device or system, or to affect its safety or effectiveness.



National Semiconductor
Americas Customer
Support Center
Email: new.feedback@nsc.com
Tel: 1-800-272-9959

www.national.com

National Semiconductor
Europe Customer Support Center
Fax: +49 (0) 180-530 85 86
Email: europa.support@nsc.com
Deutsch Tel: +49 (0) 69 9508 6208
English Tel: +44 (0) 870 24 0 2171
Français Tel: +33 (0) 1 41 91 8790

National Semiconductor
Asia Pacific Customer
Support Center
Fax: +65-6250 4466
Email: ap.support@nsc.com
Tel: +65-6254 4466

National Semiconductor
Japan Customer Support Center
Fax: 81-3-5639-7507
Email: jpn.feedback@nsc.com
Tel: 81-3-5639-7560