

LMX2330L/LMX2331L/LMX2332L PLLatinum™ Low Power Dual Frequency Synthesizer for RF Personal Communications

LMX2330L 2.5 GHz/510 MHz

LMX2331L 2.0 GHz/510 MHz

LMX2332L 1.2 GHz/510 MHz

General Description

The LMX233XL family of monolithic, integrated dual frequency synthesizers, including prescalers, is to be used as a local oscillator for RF and first IF of a dual conversion transceiver. It is fabricated using National's 0.5μ ABiC V silicon BiCMOS process.

The LMX233XL contains dual modulus prescalers. A 64/65 or a 128/129 prescaler (32/33 or 64/65 in the 2.5 GHz LMX2330L) can be selected for the RF synthesizer and a 8/9 or a 16/17 prescaler can be selected for the IF synthesizer. LMX233XL, which employs a digital phase locked loop technique, combined with a high quality reference oscillator, provides the tuning voltages for voltage controlled oscillators to generate very stable, low noise signals for RF and IF local oscillators. Serial data is transferred into the LMX233XL via a three wire interface (Data, Enable, Clock). Supply voltage can range from 2.7V to 5.5V. The LMX233XL family features very low current consumption;

LMX2330L—5.0 mA at 3V, LMX2331L—4.0 mA at 3V, LMX2332L—3.0 mA at 3V.

The LMX233XL are available in a TSSOP 20-pin, CSP 24-pin surface mount plastic package, and thin CSP 20-pin surface mount plastic package.

Features

- Ultra low current consumption
- 2.7V to 5.5V operation
- Selectable synchronous or asynchronous powerdown mode:
 $I_{CC} = 1 \mu A$ typical at 3V
- Dual modulus prescaler:

LMX2330L	(RF) 32/33 or 64/65
LMX2331L/32L	(RF) 64/65 or 128/129
LMX2330L/31L/32L	(IF) 8/9 or 16/17
- Selectable charge pump TRI-STATE® mode
- Selectable charge pump current levels
- Selectable Fastlock™ mode
- Upgrade and compatible to LMX233XA family

Applications

- Portable Wireless Communications (PCS/PCN, cordless)
- Cordless and cellular telephone systems
- Wireless Local Area Networks (WLANs)
- Cable TV tuners (CATV)
- Other wireless communication systems

Functional Block Diagram

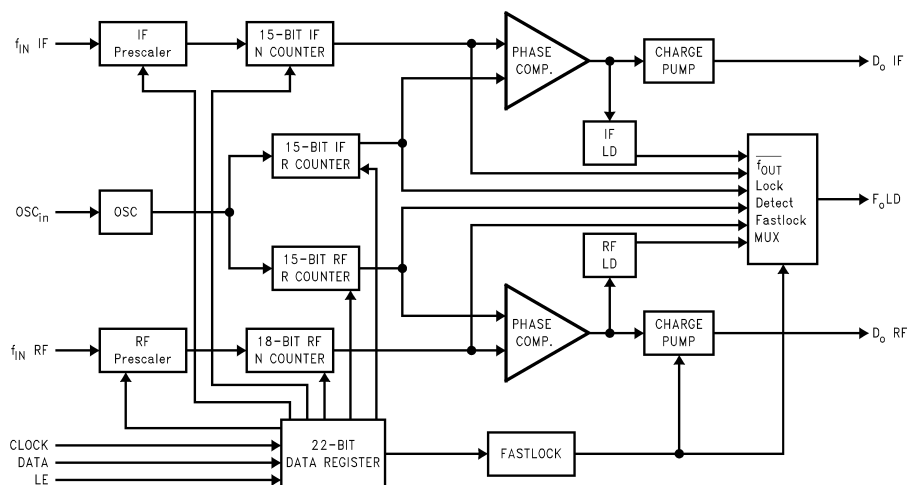

Connection Diagrams

**Chip Scale Package (SLB)
(Top View)**

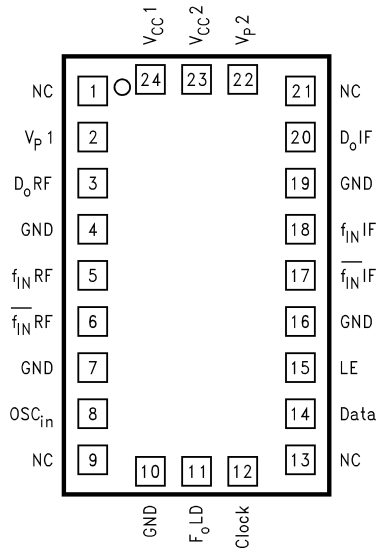

01280639

**Order Number LMX2330LSBX, LMX2331LSLBX or
LMX2332LSLBX
NS Package Number SLB24A**

**20-Pin Thin Chipscale Package (SLD)
(Top View)**

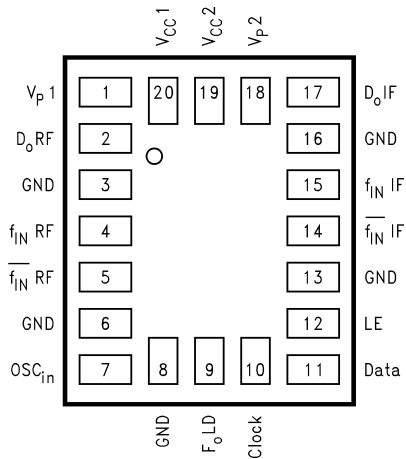

01280640

**Order Number LMX2330LSLDX, LMX2331LSLDX, or
LMX2332LSLDX
NS Package Number SLD20A**

**Thin Shrink Small Outline Package (TM)
(Top View)**

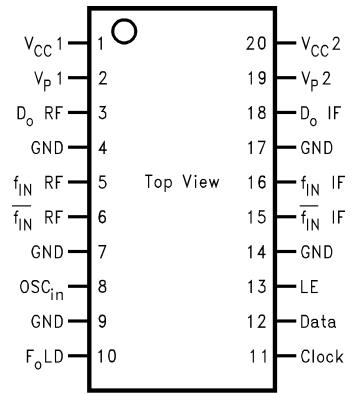

01280602

**Order Number LMX2330LTM, LMX2331LTM or
LMX2332LTM
Order Number LMX2330LTMX, LMX2331LTMX, or
LMX2332LTMX
NS Package Number MTC20**

Pin Descriptions

Pin No. LMX233XLSLD 20-pin Thin CSP Package	Pin No. LMX233XLSLB 24-pin CSP Package	Pin No. LMX233XLTM 20-pin TSSOP Package	Pin Name	I/O	Description
20	24	1	V_{CC1}	—	Power supply voltage input for RF analog and RF digital circuits. Input may range from 2.7V to 5.5V. V_{CC1} must equal V_{CC2} . Bypass capacitors should be placed as close as possible to this pin and be connected directly to the ground plane.
1	2	2	V_P1	—	Power Supply for RF charge pump. Must be $\geq V_{CC}$.
2	3	3	D_o RF	O	Internal charge pump output. For connection to a loop filter for driving the input of an external VCO.
3	4	4	GND	—	Ground for RF digital circuitry.
4	5	5	f_{IN} RF	I	RF prescaler input. Small signal input from the VCO.
5	6	6	$\overline{f_{IN}}$ RF	I	RF prescaler complementary input. A bypass capacitor should be placed as close as possible to this pin and be connected directly to the ground plane. Capacitor is optional with some loss of sensitivity.
6	7	7	GND	—	Ground for RF analog circuitry.
7	8	8	OSC_{in}	I	Oscillator input. The input has a $V_{CC}/2$ input threshold and can be driven from an external CMOS or TTL logic gate.
8	10	9	GND	—	Ground for IF digital, MICROWIRE™, F_oLD , and oscillator circuits.
9	11	10	F_oLD	O	Multiplexed output of the RF/IF programmable or reference dividers, RF/IF lock detect signals and Fastlock mode. CMOS output (see <i>Programmable Modes</i>).
10	12	11	Clock	I	High impedance CMOS Clock input. Data for the various counters is clocked in on the rising edge, into the 22-bit shift register.
11	14	12	Data	I	Binary serial data input. Data entered MSB first. The last two bits are the control bits. High impedance CMOS input.
12	15	13	LE	I	Load enable high impedance CMOS input. When LE goes HIGH, data stored in the shift registers is loaded into one of the 4 appropriate latches (control bit dependent).
13	16	14	GND	—	Ground for IF analog circuitry.
14	17	15	$\overline{f_{IN}}$ IF	I	IF prescaler complementary input. A bypass capacitor should be placed as close as possible to this pin and be connected directly to the ground plane. Capacitor is optional with some loss of sensitivity.
15	18	16	f_{IN} RF	I	IF prescaler input. Small signal input from the VCO.
16	19	17	GND	—	Ground for IF digital, MICROWIRE, F_oLD , and oscillator circuits.
17	20	18	D_o IF	O	IF charge pump output. For connection to a loop filter for driving the input of an external VCO.
18	22	19	V_P2	—	Power Supply for IF charge pump. Must be $\geq V_{CC}$.
19	23	20	V_{CC2}	—	Power supply voltage input for IF analog, IF digital, MICROWIRE, F_oLD , and oscillator circuits. Input may range from 2.7V to 5.5V. V_{CC2} must equal V_{CC1} . Bypass capacitors should be placed as close as possible to this pin and be connected directly to the ground plane.
X	1, 9, 13, 21	X	NC	—	No connect.

Block Diagram

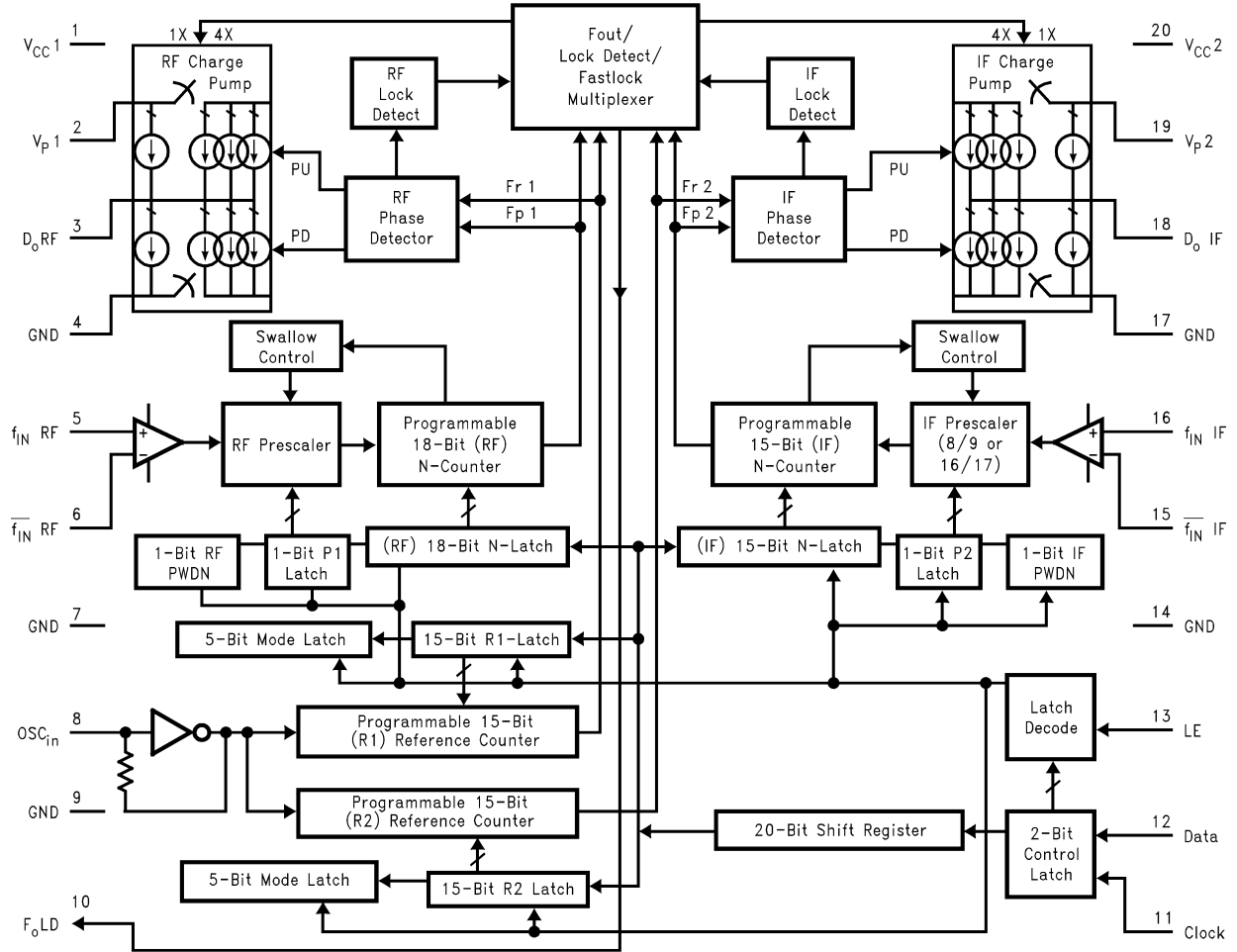

01280603

Note: The RF prescaler for the LMX2331L/32L is either 64/65 or 128/129, while the prescaler for the LMX2330L is 32/33 or 64/65.
Note: V_{CC1} supplies power to the RF prescaler, N-counter, R-counter and phase detector. V_{CC2} supplies power to the IF prescaler, N-counter, phase detector, R-counter along with the OSC_{in} buffer, MICROWIRE, and F_oLD . V_{CC1} and V_{CC2} are clamped to each other by diodes and must be run at the same voltage level.
Note: V_{P1} and V_{P2} can be run separately as long as $V_P \geq V_{CC}$.

Absolute Maximum Ratings (Notes 1, 2)

If Military/Aerospace specified devices are required, please contact the National Semiconductor Sales Office/Distributors for availability and specifications.

Power Supply Voltage	
V_{CC}	-0.3V to +6.5V
V_P	-0.3V to +6.5V
Voltage on Any Pin	
with GND = 0V (V_I)	-0.3V to $V_{CC}+0.3V$
Storage Temperature Range (T_S)	-65°C to +150°C
Lead Temperature (solder 4 sec.) (T_L)	+260°C

Recommended Operating Conditions

Power Supply Voltage	
V_{CC}	2.7V to 5.5V
V_P	V_{CC} to +5.5V
Operating Temperature (T_A)	-40°C to +85°C

Note 1: Absolute Maximum Ratings indicate limits beyond which damage to the device may occur. Recommended Operating Conditions indicate conditions for which the device is intended to be functional, but do not guarantee specific performance limits. For guaranteed specifications and test conditions, see the Electrical Characteristics. The guaranteed specifications apply only for the test conditions listed.

Note 2: This device is a high performance RF integrated circuit with an ESD rating <2 keV and is ESD sensitive. Handling and assembly of this device should only be done at ESD protected work stations.

Electrical Characteristics

$V_{CC} = 3.0V$, $V_P = 3.0V$; $-40^\circ C < T_A < 85^\circ C$, except as specified

Symbol	Parameter		Conditions	Value			Units
				Min	Typ	Max	
I_{CC}	Power Supply Current	LMX2330L RF + IF	$V_{CC} = 2.7V$ to 5.5V		5.0	6.6	mA
		LMX2330L RF Only			4.0	5.2	
		LMX2331L RF + IF			4.0	5.4	
		LMX2331L RF Only			3.0	4.0	
		LMX2332L IF + RF			3.0	4.1	
		LMX2332L RF Only			2.0	2.7	
		LMX233xL IF Only			1.0	1.4	
$I_{CC-PWDN}$	Powerdown Current		(Note 3)		1	10	μA
f_{IN} RF	Operating Frequency	LMX2330L		0.5		2.5	GHz
		LMX2331L		0.2		2.0	
		LMX2332L		0.1		1.2	
f_{IN} IF	Operating Frequency	LMX233xL		45		510	MHz
f_{OSC}	Oscillator Frequency			5		40	MHz
f_ϕ	Maximum Phase Detector Frequency			10			MHz
Pf_{IN} RF	RF Input Sensitivity		$V_{CC} = 3.0V$	-15		0	dBm
			$V_{CC} = 5.0V$	-10		0	dBm
Pf_{IN} IF	IF Input Sensitivity		$V_{CC} = 2.7V$ to 5.5V	-10		0	dBm
V_{OSC}	Oscillator Sensitivity		OSC_{in}	0.5			V_{PP}
V_{IH}	High-Level Input Voltage		(Note 4)	0.8 V_{CC}			V
V_{IL}	Low-Level Input Voltage		(Note 4)			0.2 V_{CC}	V
I_{IH}	High-Level Input Current		$V_{IH} = V_{CC} = 5.5V$ (Note 4)	-1.0		1.0	μA
I_{IL}	Low-Level Input Current		$V_{IL} = 0V$, $V_{CC} = 5.5V$ (Note 4)	-1.0		1.0	μA
I_{IH}	Oscillator Input Current		$V_{IH} = V_{CC} = 5.5V$			100	μA
I_{IL}	Oscillator Input Current		$V_{IL} = 0V$, $V_{CC} = 5.5V$	-100			μA
V_{OH}	High-Level Output Voltage (for F_oLD , pin number 10)		$I_{OH} = -500 \mu A$	$V_{CC} - 0.4$			V
V_{OL}	Low-Level Output Voltage (for F_oLD , pin number 10)		$I_{OL} = 500 \mu A$			0.4	V
t_{CS}	Data to Clock Set Up Time		See Data Input Timing	50			ns
t_{CH}	Data to Clock Hold Time		See Data Input Timing	10			ns

Electrical Characteristics (Continued)

$V_{CC} = 3.0V$, $V_P = 3.0V$; $-40^{\circ}C < T_A < 85^{\circ}C$, except as specified

Symbol	Parameter	Conditions	Value			Units
			Min	Typ	Max	
t_{CWH}	Clock Pulse Width High	See Data Input Timing	50			ns
t_{CWL}	Clock Pulse Width Low	See Data Input Timing	50			ns
t_{ES}	Clock to Load Enable Set Up Time	See Data Input Timing	50			ns
t_{EW}	Load Enable Pulse Width	See Data Input Timing	50			ns

Note 3: Clock, Data and LE = GND or V_{CC} .

Note 4: Clock, Data and LE does not include f_{IN} RF, f_{IN} IF and OSC_{IN} .

Charge Pump Characteristics

$V_{CC} = 3.0V$, $V_P = 3.0V$; $-40^{\circ}C < T_A \leq 85^{\circ}C$, except as specified

Symbol	Parameter	Conditions	Value			Units
			Min	Typ	Max	
$I_{D0-SOURCE}$	Charge Pump Output Current	$V_{D0} = V_P/2$, $I_{CP0} = HIGH$ (Note 5)		-4.0		mA
$I_{D0-SINK}$		$V_{D0} = V_P/2$, $I_{CP0} = HIGH$ (Note 5)		4.0		mA
$I_{D0-SOURCE}$		$V_{D0} = V_P/2$, $I_{CP0} = LOW$ (Note 5)		-1		mA
$I_{D0-SINK}$		$V_{D0} = V_P/2$, $I_{CP0} = LOW$ (Note 5)		1		mA
I_{D0-TRI}	Charge Pump TRI-STATE Current	$0.5V \leq V_{D0} \leq V_P - 0.5V$ $-40^{\circ}C < T_A < 85^{\circ}C$	-2.5		2.5	nA
$I_{D0-SINK}$ vs $I_{D0-SOURCE}$	CP Sink vs Source Mismatch (Note 7)	$V_{D0} = V_P/2$ $T_A = 25^{\circ}C$		3	10	%
I_{D0} vs V_{D0}	CP Current vs Voltage (Note 6)	$0.5 \leq V_{D0} \leq V_P - 0.5V$ $T_A = 25^{\circ}C$		10	15	%
I_{D0} vs T_A	CP Current vs Temperature (Note 8)	$V_{D0} = V_P/2$ $-40^{\circ}C \leq T_A \leq 85^{\circ}C$		10		%

Note 5: See PROGRAMMABLE MODES for I_{CP0} description.

Charge Pump Current Specification Definitions

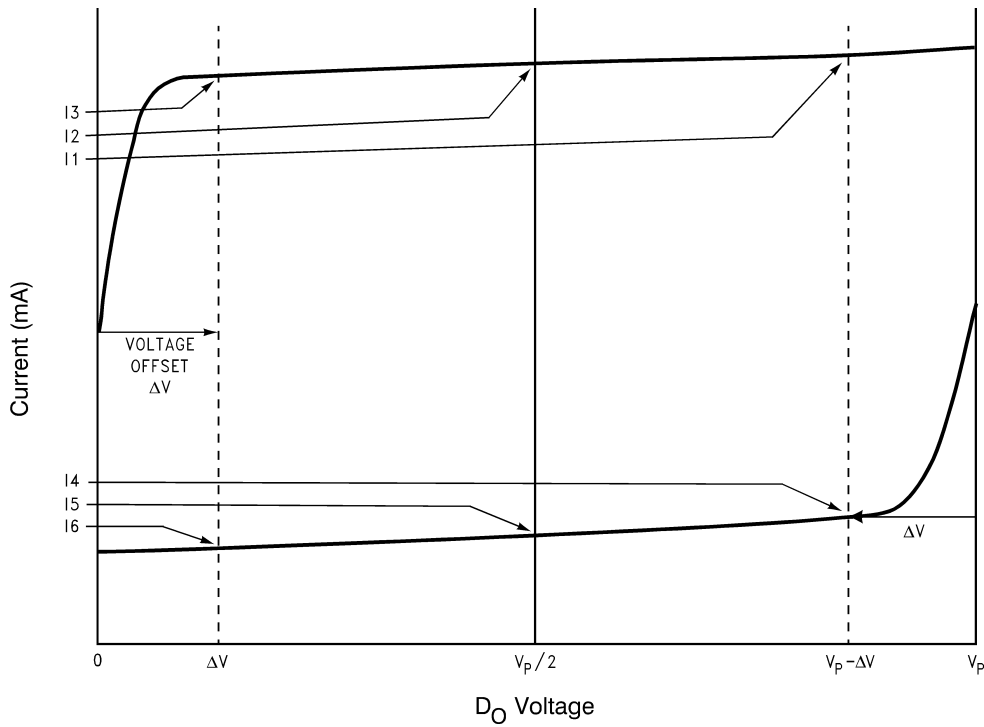

01280637

I1 = CP sink current at $V_{D_O} = V_P - \Delta V$

I2 = CP sink current at $V_{D_O} = V_P/2$

I3 = CP sink current at $V_{D_O} = \Delta V$

I4 = CP source current at $V_{D_O} = V_P - \Delta V$

I5 = CP source current at $V_{D_O} = V_P/2$

I6 = CP source current at $V_{D_O} = \Delta V$

ΔV = Voltage offset from positive and negative rails. Dependent on VCO tuning range relative to V_{CC} and ground. Typical values are between 0.5V and 1.0V.

Note 6: I_{D_O} vs V_{D_O} = Charge Pump Output Current magnitude variation vs Voltage =

$$\left[\frac{1}{2} * \{ |I1| - |I3| \} / \left[\frac{1}{2} * \{ |I1| + |I3| \} \right] \right] * 100\% \quad \text{and} \quad \left[\frac{1}{2} * \{ |I4| - |I6| \} / \left[\frac{1}{2} * \{ |I4| + |I6| \} \right] \right] * 100\%$$

Note 7: I_{D_O-sink} vs $I_{D_O-source}$ = Charge Pump Output Current Sink vs Source Mismatch =

$$\left[\frac{|I2| - |I5|}{\frac{1}{2} * \{ |I2| + |I5| \}} \right] * 100\%$$

Note 8: I_{D_O} vs T_A = Charge Pump Output Current magnitude variation vs Temperature =

$$\left[\frac{|I2 @ \text{temp}| - |I2 @ 25^\circ\text{C}|}{|I2 @ 25^\circ\text{C}|} \right] * 100\% \quad \text{and} \quad \left[\frac{|I5 @ \text{temp}| - |I5 @ 25^\circ\text{C}|}{|I5 @ 25^\circ\text{C}|} \right] * 100\%$$

RF Sensitivity Test Block Diagram

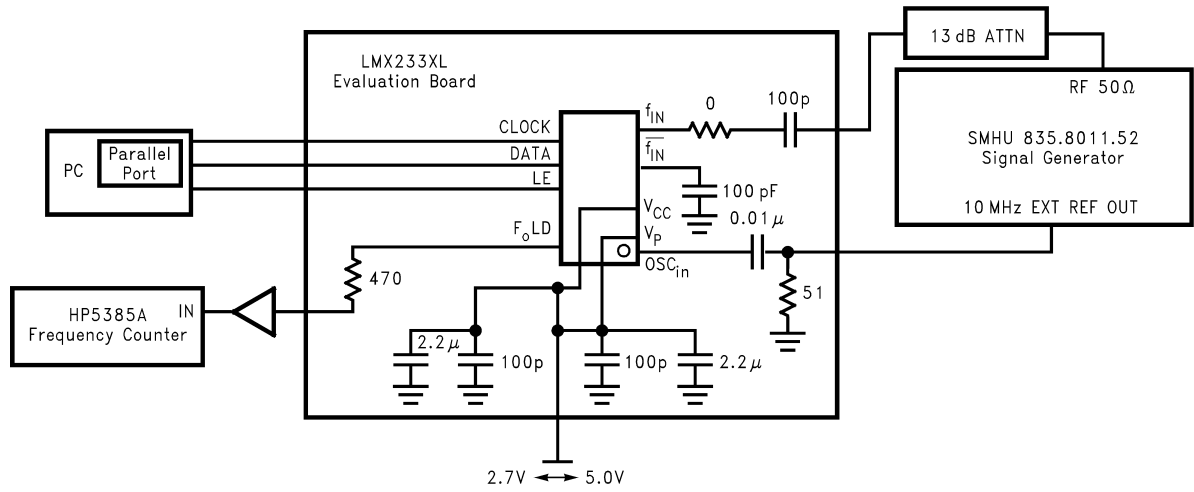

Note 1: N = 10,000 R = 50 P = 64

Note 2: Sensitivity limit is reached when the error of the divided RF output, F_oLD, is ≥ 1 Hz.

01280638

Typical Performance Characteristics

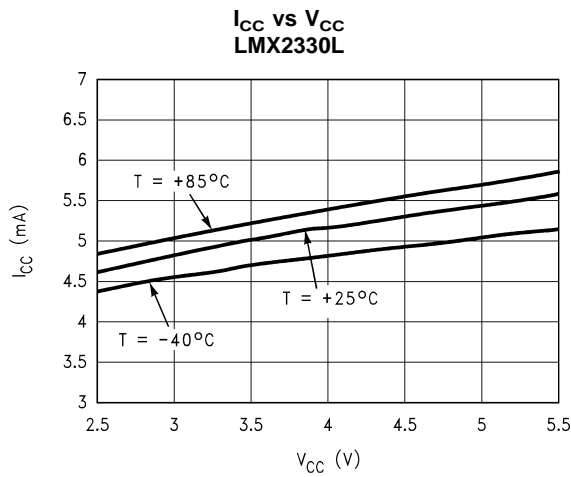

01280619

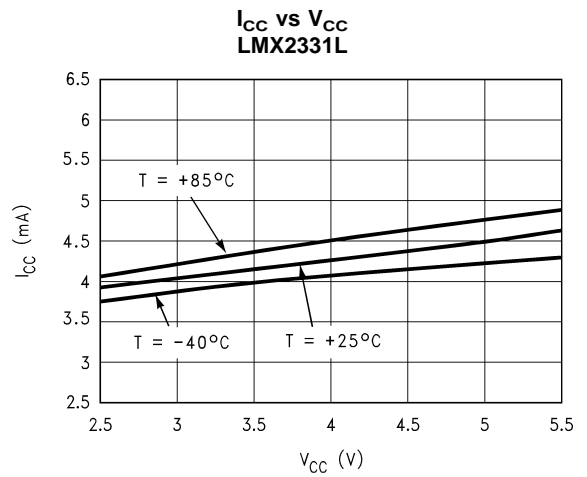

01280620

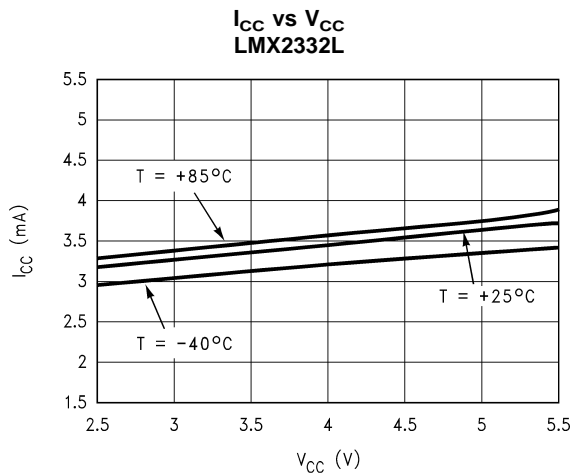

01280621

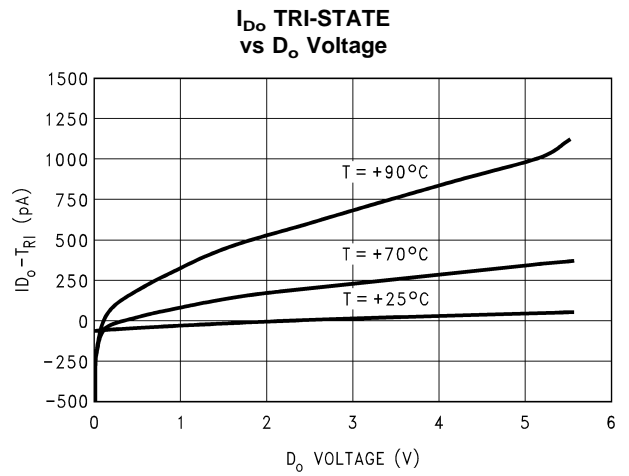

01280622

Typical Performance Characteristics (Continued)

Charge Pump Current vs D_o Voltage
 $I_{CP} = \text{HIGH}$

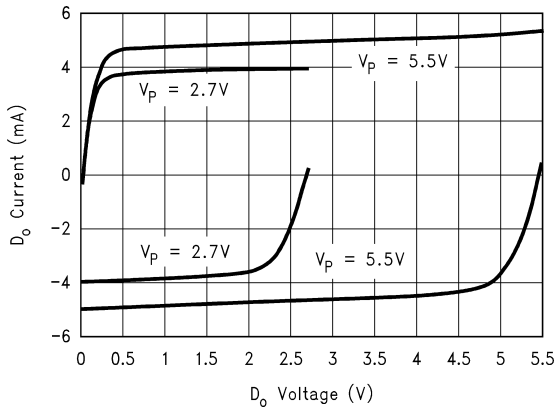

01280623

Charge Pump Current vs D_o Voltage
 $I_{CP} = \text{LOW}$

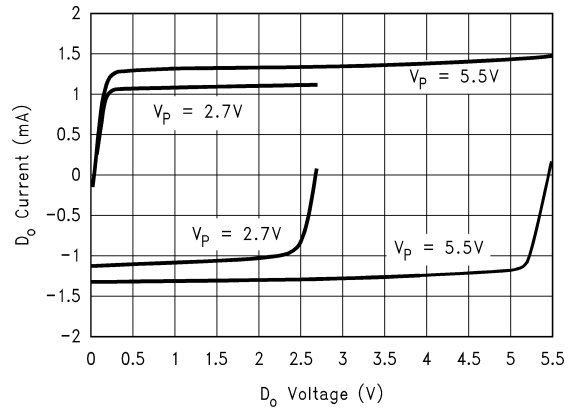

01280624

Charge Pump Current Variation
 (See (Note 6) under Charge Pump Current Specification Definitions)

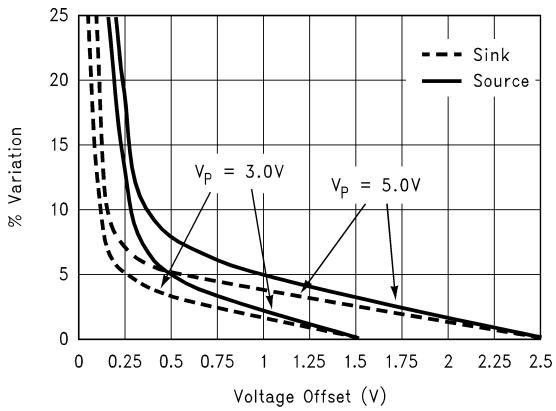

01280625

Sink vs Source Mismatch
 (See (Note 7) under Charge Pump Current Specification Definitions)

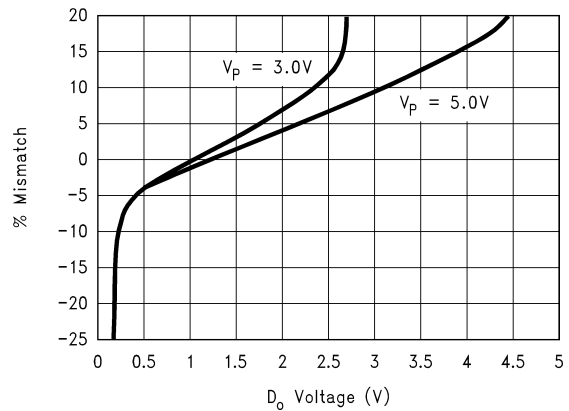

01280626

Typical Performance Characteristics (Continued)

RF Input Impedance
 $V_{CC} = 2.7V \text{ to } 5.5V, f_{IN} = 50 \text{ MHz to } 3 \text{ GHz}$

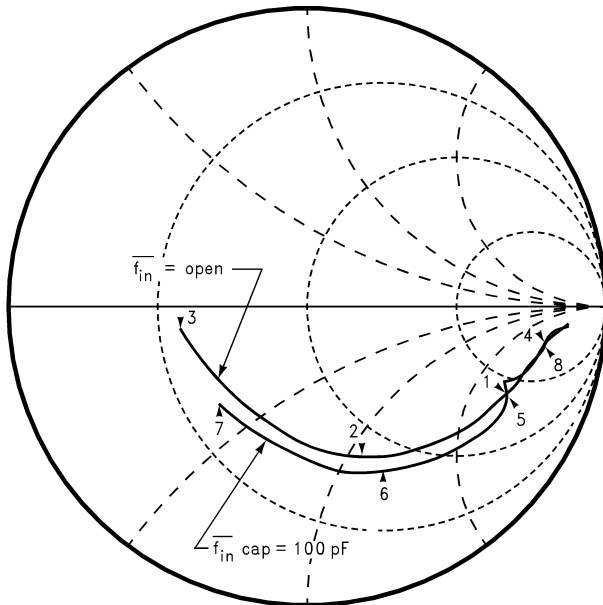

- Marker 1 = 1 GHz, Real = 123, Imaginary = -141
- Marker 2 = 2 GHz, Real = 39, Imaginary = -52
- Marker 3 = 3 GHz, Real = 21, Imaginary = -3
- Marker 4 = 500 MHz, Real = 237, Imaginary = -185
- Marker 5 = 1 GHz, Real = 128, Imaginary = -144
- Marker 6 = 2 GHz, Real = 38, Imaginary = -64
- Marker 7 = 3 GHz, Real = 24, Imaginary = -18
- Marker 8 = 500 MHz, Real = 207, Imaginary = -184

01280627

IF Input Impedance
 $V_{CC} = 2.7V \text{ to } 5.5V, f_{IN} = 50 \text{ MHz to } 1000 \text{ MHz}$

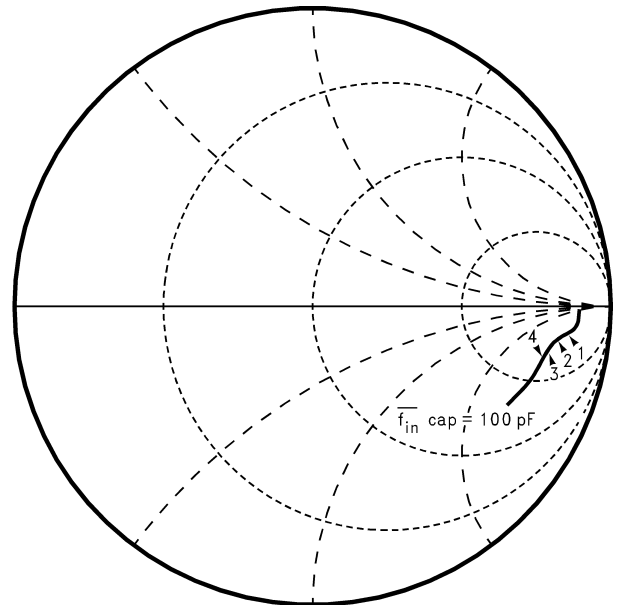

- Marker 1 = 100 MHz, Real = 443, Imaginary = -249
- Marker 2 = 200 MHz, Real = 348, Imaginary = -214
- Marker 3 = 300 MHz, Real = 297, Imaginary = -208
- Marker 4 = 500 MHz, Real = 222, Imaginary = -198

01280628

Typical Performance Characteristics (Continued)

LMX233xSLD RF Input Impedance

$V_{CC} = 2.7V$ to $5.5V$, $f_{IN} = 500$ MHz to 3 GHz, f_{IN} RF CAP = 100 pF

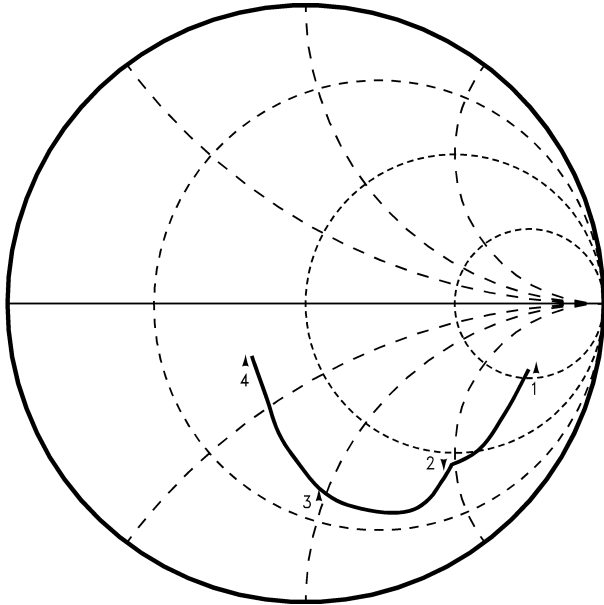

01280641

Marker 1 = 500 MHz,	Real = 202.98,	Imaginary = -200.09
Marker 2 = 1.8 GHz,	Real = 32.36,	Imaginary = -91.42
Marker 3 = 2.5GHz,	Real = 25.51,	Imaginary = -46.41
Marker 4 = 3.0 GHz,	Real = 30.46,	Imaginary = -9.50

LMX233xSLD IF Input Impedance

$V_{CC} = 2.7V$ to $5.5V$, f_{IN} IF = 100 MHz to 400 MHz, f_{IN} IF CAP = 100 pF

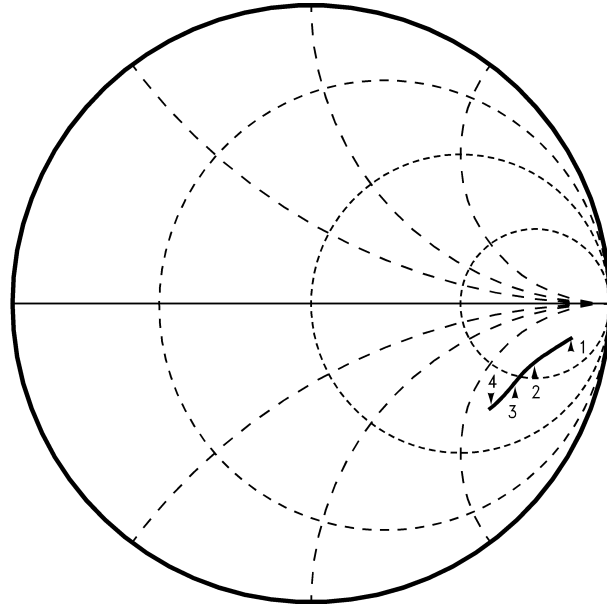

01280642

Marker 1 = 100 MHz,	Real = 374.33,	Imaginary = -301.45
Marker 2 = 200 MHz,	Real = 257.14,	Imaginary = -245.79
Marker 3 = 300 MHz,	Real = 194.08,	Imaginary = -224.24
Marker 4 = 400 MHz,	Real = 89.03,	Imaginary = -131.21

LMX2330L RF Sensitivity vs Frequency

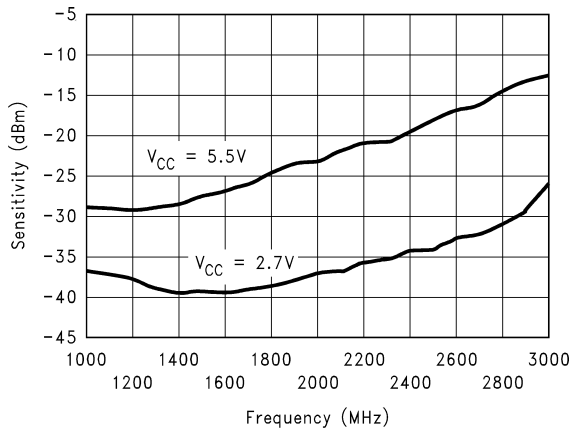

01280629

LMX2331L RF Sensitivity vs Frequency

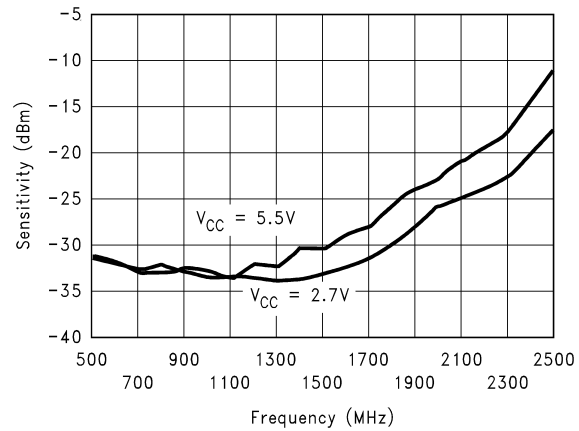

01280630

Typical Performance Characteristics (Continued)

LMX2332L RF Sensitivity vs Frequency

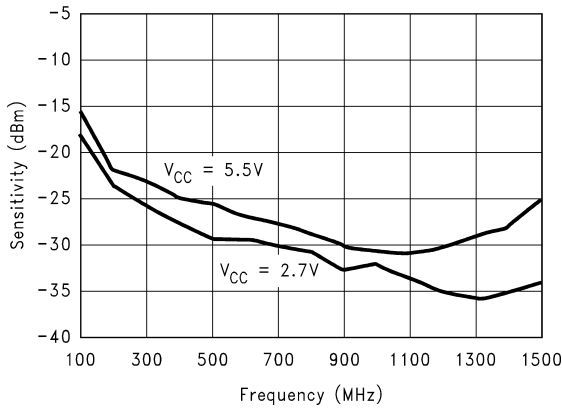

01280631

IF Input Sensitivity vs Frequency

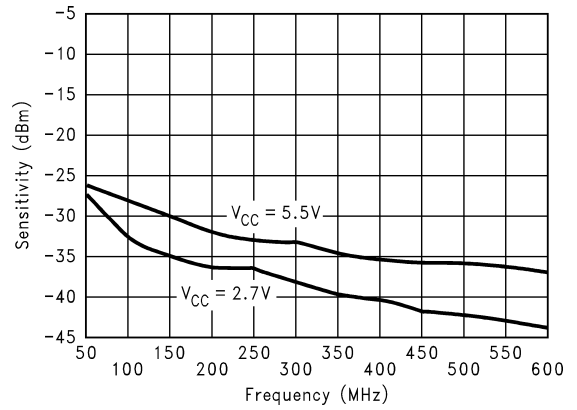

01280632

Oscillator Input Sensitivity vs Frequency

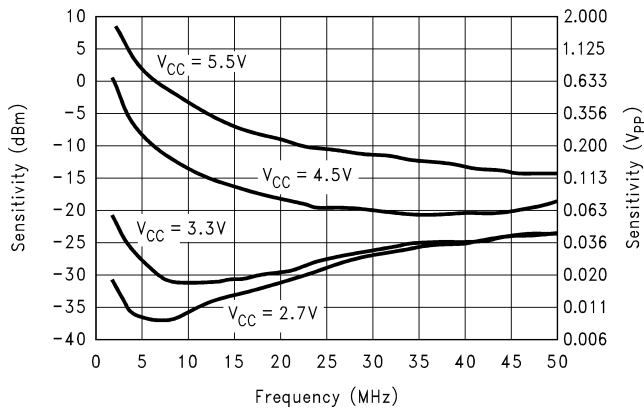

01280633

Functional Description

The simplified block diagram below shows the 22-bit data register, two 15-bit R Counters and the 15- and 18-bit N Counters (intermediate latches are not shown). The data stream is clocked (on the rising edge of Clock) into the DATA register, MSB first. The data stored in the shift register is loaded into one of 4 appropriate latches on the rising edge of LE. The last two bits are the Control Bits. The DATA is transferred into the counters as follows:

Control Bits		DATA Location
C1	C2	
0	0	IF R Counter
0	1	RF R Counter
1	0	IF N Counter
1	1	RF N Counter

Functional Description (Continued)

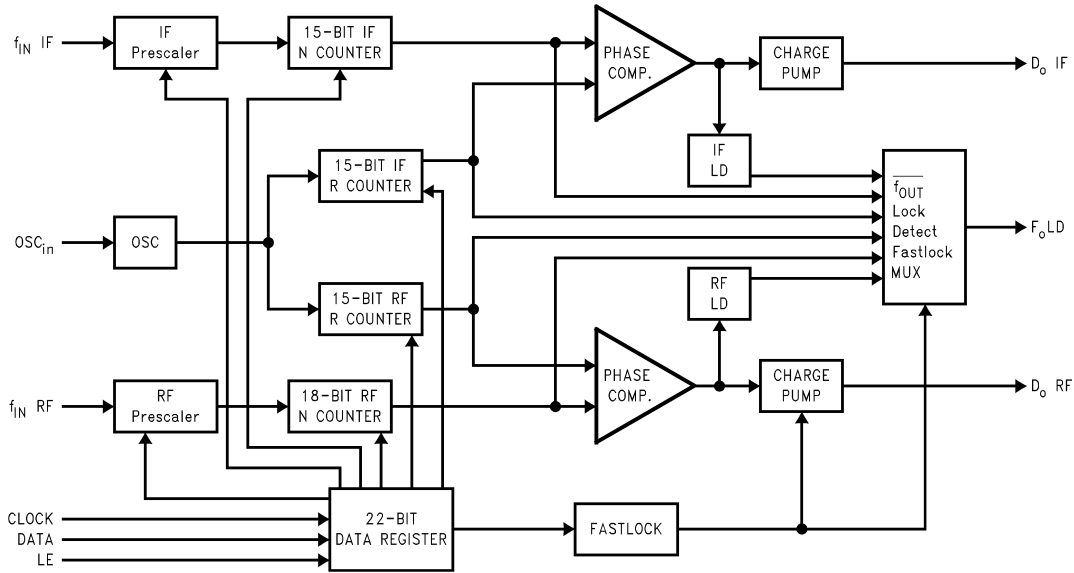

01280606

PROGRAMMABLE REFERENCE DIVIDERS (IF AND RF R COUNTERS)

If the Control Bits are 00 or 01 (00 for IF and 01 for RF) data is transferred from the 22-bit shift register into a latch which sets the 15-bit R Counter. Serial data format is shown below.

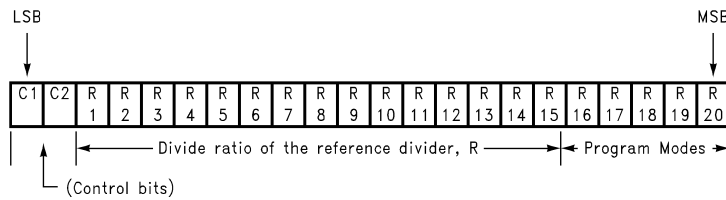

01280607

15-BIT PROGRAMMABLE REFERENCE DIVIDER RATIO (R COUNTER)

Divide Ratio	R 15	R 14	R 13	R 12	R 11	R 10	R 9	R 8	R 7	R 6	R 5	R 4	R 3	R 2	R 1
3	0	0	0	0	0	0	0	0	0	0	0	0	0	1	1
4	0	0	0	0	0	0	0	0	0	0	0	0	1	0	0
•	•	•	•	•	•	•	•	•	•	•	•	•	•	•	•
32767	1	1	1	1	1	1	1	1	1	1	1	1	1	1	1

Notes:

- Divide ratios less than 3 are prohibited.
- Divide ratio: 3 to 32767
- R1 to R15: These bits select the divide ratio of the programmable reference divider.
- Data is shifted in MSB first.

PROGRAMMABLE DIVIDER (N COUNTER)

The N counter consists of the 7-bit swallow counter (A counter) and the 11-bit programmable counter (B counter). If the Control Bits are 10 or 11 (10 for IF counter and 11 for RF counter) data is transferred from the 22-bit shift register into a 4-bit or 7-bit latch (which sets the Swallow (A) Counter) and an 11-bit latch (which sets the 11-bit programmable (B) Counter), MSB first. Serial data format is shown below. **For the IF N counter bits 5, 6, and 7 are don't care bits.** The RF N counter does not have don't care bits.

Functional Description (Continued)

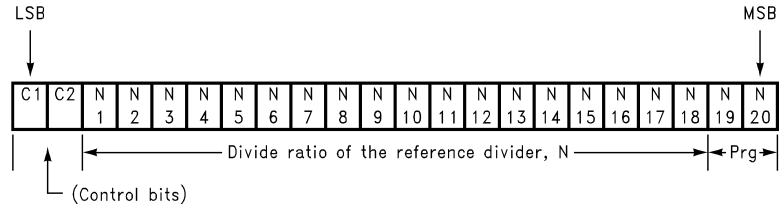

7-BIT SWALLOW COUNTER DIVIDE RATIO (A COUNTER)

Divide Ratio A	RF						
	N 7	N 6	N 5	N 4	N 3	N 2	N 1
0	0	0	0	0	0	0	0
1	0	0	0	0	0	0	1
•	•	•	•	•	•	•	•
127	1	1	1	1	1	1	1

Notes: Divide ratio: 0 to 127
B ≥ A

Divide Ratio A	IF						
	N 7	N 6	N 5	N 4	N 3	N 2	N 1
0	X	X	X	0	0	0	0
1	X	X	X	0	0	0	1
•	•	•	•	•	•	•	•
15	X	X	X	1	1	1	1

X = DON'T CARE condition

11-BIT PROGRAMMABLE COUNTER DIVIDE RATIO (B COUNTER)

Divide Ratio B	N 18	N 17	N 16	N 15	N 14	N 13	N 12	N 11	N 10	N 9	N 8
	3	0	0	0	0	0	0	0	0	0	1
4	0	0	0	0	0	0	0	0	1	0	0
•	•	•	•	•	•	•	•	•	•	•	•
2047	1	1	1	1	1	1	1	1	1	1	1

Note: Divide ratio: 3 to 2047 (Divide ratios less than 3 are prohibited)
B ≥ A

PULSE SWALLOW FUNCTION

$$f_{VCO} = [(P \times B) + A] \times f_{OSC} / R$$

f_{VCO} : Output frequency of external voltage controlled oscillator (VCO)

B: Preset divide ratio of binary 11-bit programmable counter (3 to 2047)

A: Preset divide ratio of binary 7-bit swallow counter

$$(0 \leq A \leq 127 \text{ (RF)}, 0 \leq A \leq 15 \text{ (IF)}, A \leq B)$$

f_{OSC} : Output frequency of the external reference frequency oscillator

R: Preset divide ratio of binary 15-bit programmable reference counter (3 to 32767)

P: Preset modulus of dual modulus prescaler (for IF; P = 8 or 16;

for RF; LMX2330L: P = 32 or 64 LMX2331L/32L: P = 64 or 128)

Functional Description (Continued)

PROGRAMMABLE MODES

Several modes of operation can be programmed with bits R16–R20 including the phase detector polarity, charge pump TRI-STATE and the output of the F_oLD pin. The prescaler and powerdown modes are selected with bits N19 and N20. The programmable modes are shown in *Table 1*. Truth table for the programmable modes and F_oLD output are shown in *Table 2* and *Table 3*.

TABLE 1. Programmable Modes

C1	C2	R16	R17	R18	R19	R20
0	0	IF Phase Detector Polarity	IF I _{CPo}	IF D _o TRI-STATE	IF LD	IF F _o
0	1	RF Phase Detector Polarity	RF I _{CPo}	RF D _o TRI-STATE	RF LD	RF F _o

C1	C2	N19	N20
1	0	IF Prescaler	Pwdn IF
1	1	RF Prescaler	Pwdn RF

TABLE 2. Mode Select Truth Table

	Phase Detector Polarity (Note 11)	D _o TRI-STATE (Note 9)	I _{CPo} (Note 10)	IF Prescaler	2330L RF Prescaler	2331L/32L RF Prescaler	Pwdn (Note 9)
0	Negative	Normal Operation	LOW	8/9	32/33	64/65	PwrD Up
1	Positive	TRI-STATE	HIGH	16/17	64/65	128/129	PwrD Dn

Note 9: Refer to POWERDOWN OPERATION in Functional Description.

Note 10: The I_{CPo} LOW current state = 1/4 x I_{CPo} HIGH current.

Note 11: PHASE DETECTOR POLARITY

Depending upon VCO characteristics, R16 bit should be set accordingly: (see figure right)

When VCO characteristics are positive like (1), R16 should be set HIGH;

When VCO characteristics are negative like (2), R16 should be set LOW.

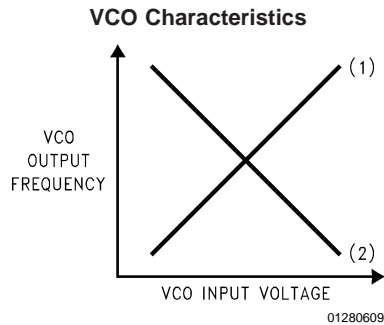

Functional Description (Continued)

TABLE 3. The F_oLD (Pin 10) Output Truth Table

RF R[19] (RF LD)	IF R[19] (IF LD)	RF R[20] (RF F _o)	IF R[20] (IF F _o)	F _o Output State
0	0	0	0	Disabled (Note 12)
0	1	0	0	IF Lock Detect (Note 13)
1	0	0	0	RF Lock Detect (Note 13)
1	1	0	0	RF/IF Lock Detect (Note 13)
X	0	0	1	IF Reference Divider Output
X	0	1	0	RF Reference Divider Output
X	1	0	1	IF Programmable Divider Output
X	1	1	0	RF Programmable Divider Output
0	0	1	1	Fastlock (Note 14)
0	1	1	1	IF Counter Reset (Note 15)
1	0	1	1	RF Counter Reset (Note 15)
1	1	1	1	IF and RF Counter Reset (Note 15)

X = don't care condition

Note 12: When the F_oLD output is disabled, it is actively pulled to a low logic state.

Note 13: Lock detect output provided to indicate when the VCO frequency is in "lock." When the loop is locked and a lock detect mode is selected, the pins output is HIGH, with narrow pulses LOW. In the RF/IF lock detect mode a locked condition is indicated when RF and IF are both locked.

Note 14: The Fastlock mode utilizes the F_oLD output pin to switch a second loop filter damping resistor to ground during fastlock operation. Activation of Fastlock occurs whenever the RF loop's Icpo magnitude bit #17 is selected HIGH (while the #19 and #20 mode bits are set for Fastlock).

Note 15: The IF Counter Reset mode resets IF PLL's R and N counters and brings IF charge pump output to a TRI-STATE condition. The RF Counter Reset mode resets RF PLL's R and N counters and brings RF charge pump output to a TRI-STATE condition. The IF and RF Counter Reset mode resets all counters and brings both charge pump outputs to a TRI-STATE condition. Upon removal of the Reset bits then N counter resumes counting in "close" alignment with the R counter. (The maximum error is one prescaler cycle.)

POWERDOWN OPERATION

Synchronous and asynchronous powerdown modes are both available by MICROWIRE selection. Synchronously powerdown occurs if the respective loop's R18 bit (Do TRI-STATE) is LOW when its N20 bit (PwDn) becomes HI. Asynchronous powerdown occurs if the loop's R18 bit is HI when its N20 bit becomes HI.

In the synchronous powerdown mode, the powerdown function is gated by the charge pump to prevent unwanted frequency jumps. Once the powerdown program bit N20 is loaded, the part will go into powerdown mode when the charge pump reaches a TRI-STATE condition.

In the asynchronous powerdown mode, the device powers down immediately after the LE pin latches in a HI condition on the powerdown bit N20.

Activation of either the IF or RF PLL powerdown conditions in either synchronous or asynchronous modes forces the respective loop's R and N dividers to their load state condition and debiasing of its respective f_{IN} input to a high impedance state. The oscillator circuitry function does not become disabled until both IF and RF powerdown bits are activated. The MICROWIRE control register remains active and capable of loading and latching data during all of the powerdown modes.

The device returns to an actively powered up condition in either synchronous or asynchronous modes immediately upon LE latching LOW data into bit N20.

Powerdown Mode Select Table

R18	N20	Powerdown Status
0	0	PLL Active
1	0	PLL Active (Charge Pump Output TRI-STATE)
0	1	Synchronous Powerdown Initiated
1	1	Asynchronous Powerdown Initiated

Functional Description (Continued)

SERIAL DATA INPUT TIMING

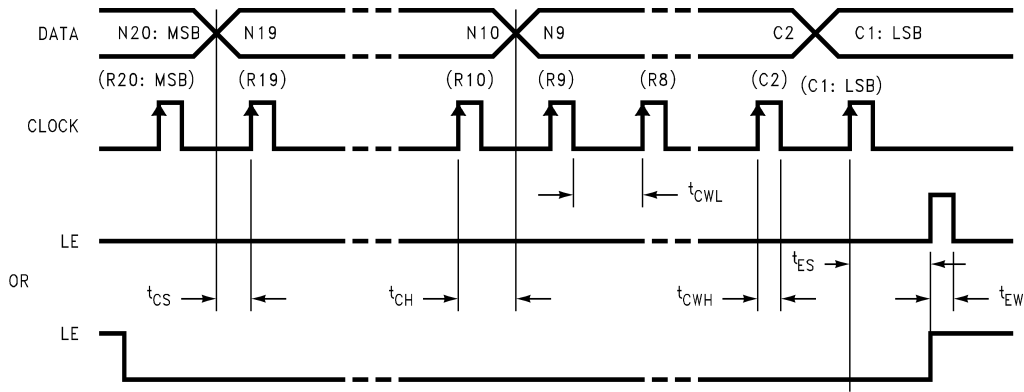

01280610

Note 1: Parenthesis data indicates programmable reference divider data.

Data shifted into register on clock rising edge.

Data is shifted in MSB first.

Note 2: t_{cs} = Data to Clock Set-Up Time

t_{ch} = Data to Clock Hold Time

t_{cwh} = Clock Pulse Width High

t_{cwl} = Clock Pulse Width Low

t_{es} = Clock to Load Enable Set-Up Time

t_{ew} = Load Enable Pulse Width

Test Conditions: The Serial Data Input Timing is tested using a symmetrical waveform around $V_{CC}/2$. The test waveform has an edge rate of 0.6 V/ns with amplitudes of 2.2V @ $V_{CC} = 2.7V$ and 2.6V @ $V_{CC} = 5.5V$.

PHASE COMPARATOR AND INTERNAL CHARGE PUMP CHARACTERISTICS

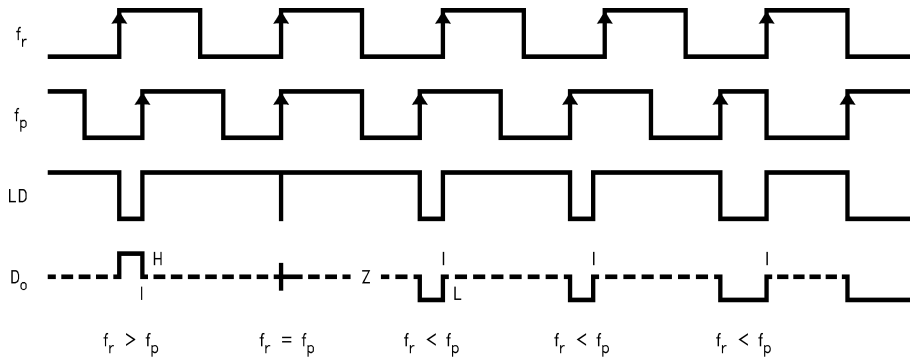

01280611

Notes: Phase difference detection range: -2π to $+2\pi$

The minimum width pump up and pump down current pulses occur at the D_o pin when the loop is locked.

R16 = HIGH

Typical Application Example

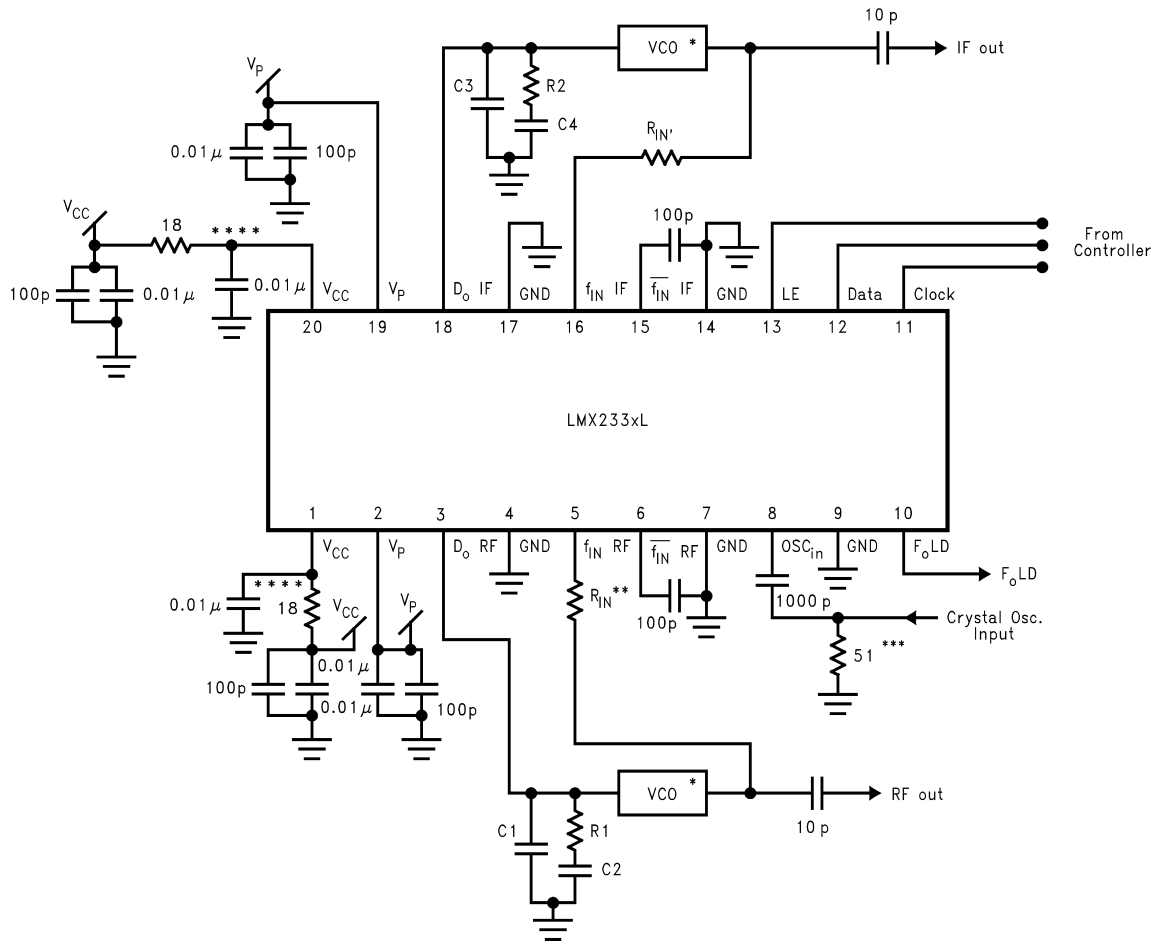

01280612

Operational Notes:

* VCO is assumed AC coupled.

** R_{IN} increases impedance so that VCO output power is provided to the load rather than the PLL. Typical values are 10Ω to 200Ω depending on the VCO power level. f_{IN} RF impedance ranges from 40Ω to 100Ω. f_{IN} IF impedances are higher.

*** Adding RC filters to the V_{CC} lines is recommended to reduce loop-to-loop noise coupling.

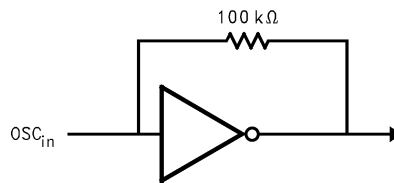

01280613

Application Hints:

Proper use of grounds and bypass capacitors is essential to achieve a high level of performance. Crosstalk between pins can be reduced by careful board layout.

This is an electrostatic sensitive device. It should be handled only at static free work stations.

Application Information

A block diagram of the basic phase locked loop is shown in *Figure 1*.

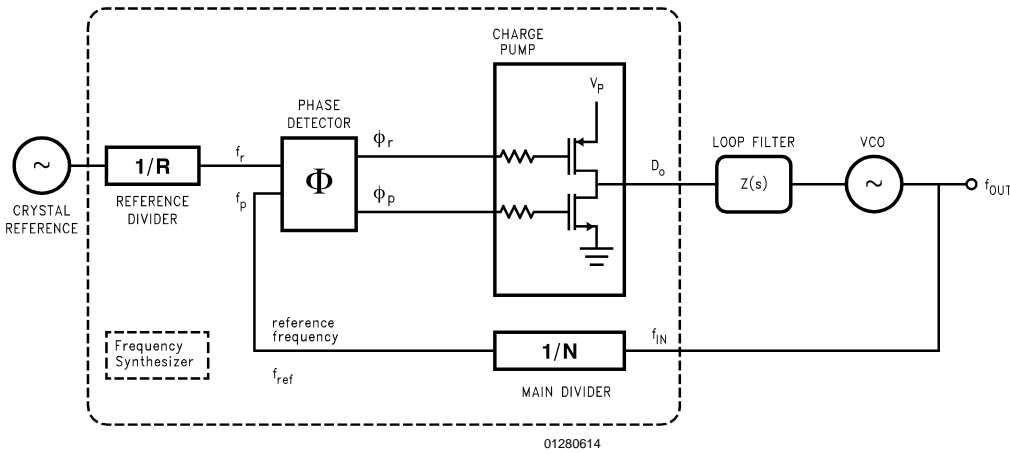

FIGURE 1. Basic Charge Pump Phase Locked Loop

LOOP GAIN EQUATIONS

A linear control system model of the phase feedback for a PLL in the locked state is shown in *Figure 2*. The open loop gain is the product of the phase comparator gain (K_ϕ), the VCO gain (K_{VCO}/s), and the loop filter gain $Z(s)$ divided by the gain of the feedback counter modulus (N). The passive loop filter configuration used is displayed in *Figure 3*, while the complex impedance of the filter is given in *Equation (1)*.

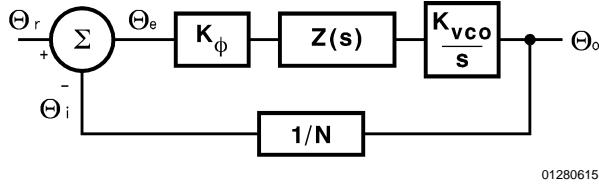

FIGURE 2. PLL Linear Model

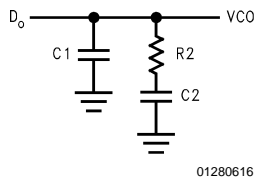

FIGURE 3. Passive Loop Filter

$$\begin{aligned} \text{Open loop gain} &= H(s)G(s) = \Theta_i/\Theta_e \\ &= K_\phi Z(s) K_{VCO}/Ns \\ Z(s) &= \frac{s(C2 \cdot R2) + 1}{s^2(C1 \cdot C2 \cdot R2) + sC1 + sC2} \end{aligned} \quad (1)$$

The time constants which determine the pole and zero frequencies of the filter transfer function can be defined as

$$T1 = R2 \cdot \frac{C1 \cdot C2}{C1 + C2} \quad (2)$$

and

$$T2 = R2 \cdot C2 \quad (3)$$

The 3rd order PLL Open Loop Gain can be calculated in terms of frequency, ω , the filter time constants $T1$ and $T2$, and the design constants K_ϕ , K_{VCO} , and N .

$$G(s) \cdot H(s)|_{s=j \cdot \omega} = \frac{-K_\phi \cdot K_{VCO} (1 + j\omega \cdot T2)}{\omega^2 C1 \cdot N (1 + j\omega \cdot T1)} \cdot \frac{T1}{T2} \quad (4)$$

From *Equations (2), (3)* we can see that the phase term will be dependent on the single pole and zero such that the phase margin is determined in *Equation (5)*.

$$\phi(\omega) = \tan^{-1}(\omega \cdot T2) - \tan^{-1}(\omega \cdot T1) + 180^\circ \quad (5)$$

A plot of the magnitude and phase of $G(s)H(s)$ for a stable loop, is shown in *Figure 4* with a solid trace. The parameter ϕ_p shows the amount of phase margin that exists at the point the gain drops below zero (the cutoff frequency ω_p of the loop). In a critically damped system, the amount of phase margin would be approximately 45 degrees.

If we were now to redefine the cut off frequency, ω_p' , as double the frequency which gave us our original loop bandwidth, ω_p , the loop response time would be approximately halved. Because the filter attenuation at the comparison frequency also diminishes, the spurs would have increased by approximately 6 dB. In the proposed Fastlock scheme, the higher spur levels and wider loop filter conditions would exist only during the initial lock-on phase—just long enough to reap the benefits of locking faster. The objective would be to open up the loop bandwidth but not introduce any additional complications or compromises related to our original design criteria. We would ideally like to momentarily shift the curve of *Figure 4* over to a different cutoff frequency, illustrated by the dotted line, without affecting the relative open loop gain and phase relationships. To maintain the same gain/phase relationship at twice the original cutoff frequency, other terms in the gain and phase *Equation (4)* and *Equation (5)* will have to compensate by the corresponding “ $1/\omega$ ” or “ $1/\omega^2$ ” factor. Examination of equations *Equations (2), (3)* and *Equation (5)* indicates the damping resistor variable $R2$ could be chosen to compensate the “ ω ” terms for the phase

Application Information (Continued)

margin. This implies that another resistor of equal value to R2 will need to be switched in parallel with R2 during the initial lock period. We must also insure that the magnitude of the open loop gain, $H(s)G(s)$ is equal to zero at $\omega_p' = 2\omega_p$. K_{VCO} , $K\phi$, N, or the net product of these terms can be

changed by a factor of 4, to counteract the ω^2 term present in the denominator of *Equation (2)* and *Equation (3)*. The $K\phi$ term was chosen to complete the transformation because it can readily be switched between 1X and 4X values. This is accomplished by increasing the charge pump output current from 1 mA in the standard mode to 4 mA in Fastlock.

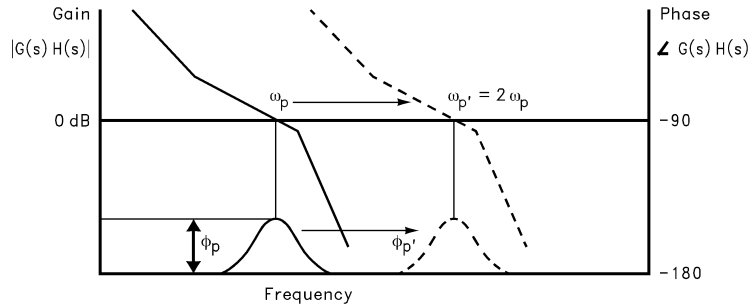

01280617

FIGURE 4. Open Loop Response Bode Plot

FASTLOCK CIRCUIT IMPLEMENTATION

A diagram of the Fastlock scheme as implemented in National Semiconductors LMX233XL PLL is shown in *Figure 5*. When a new frequency is loaded, and the RF Icp_o bit is set high the charge pump circuit receives an input to deliver 4 times the normal current per unit phase error while an open drain NMOS on chip device switches in a second R2 resistor to ground. The user calculates the loop filter component values for the normal steady state considerations. The device configuration ensures that as long as a second

identical damping resistor is wired in appropriately, the loop will lock faster without any additional stability considerations to account for. Once locked on the correct frequency, the user can return the PLL to standard low noise operation by sending a MICROWIRE instruction with the RF Icp_o bit set low. This transition does not affect the charge on the loop filter capacitors and is enacted synchronous with the charge pump output. This creates a nearly seamless change between Fastlock and standard mode.

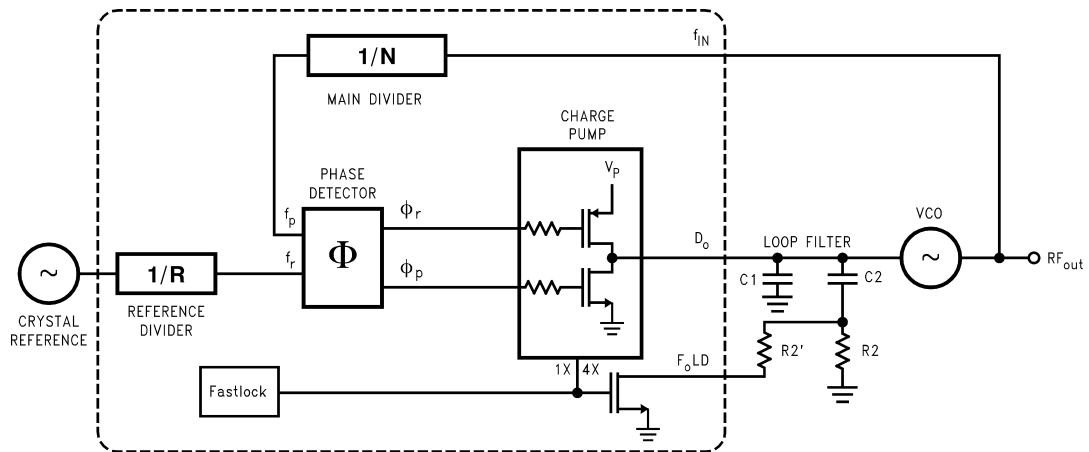

01280618

FIGURE 5. Fastlock PLL Architecture

Physical Dimensions inches (millimeters)

unless otherwise noted

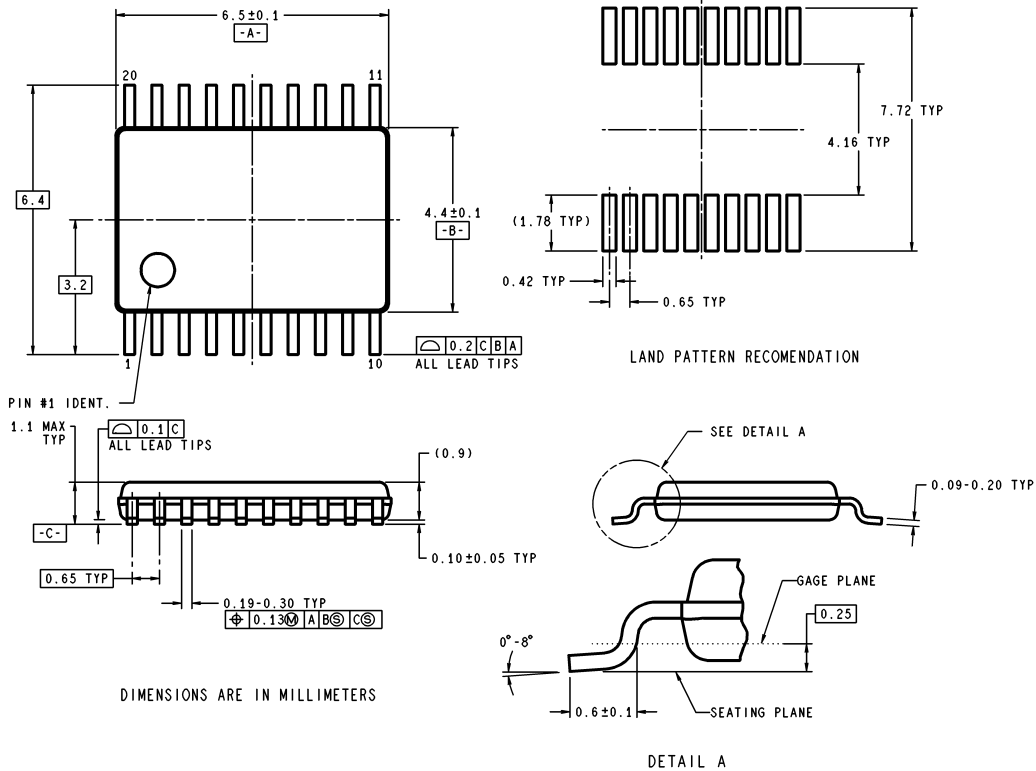

MTC20 (Rev D)

20-Lead (0.173" Wide) Thin Shrink Small Outline Package (TM)
Order Number LMX2330LTM, LMX2331LTM or LMX2332LTM
***For Tape and Reel (2500 units per reel)**
Order Number LMX2330LTMX, LMX2331LTMX or LMX2332LTMX
NS Package Number MTC20

Physical Dimensions inches (millimeters) unless otherwise noted (Continued)

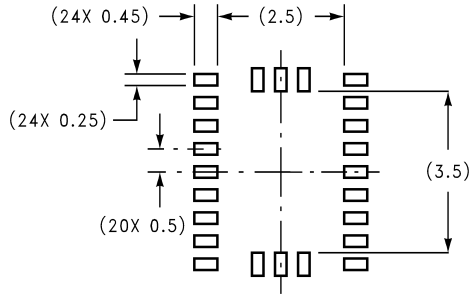

DIMENSIONS ARE IN MILLIMETERS

RECOMMENDED LAND PATTERN
1:1 RATIO WITH PACKAGE SOLDER PADS

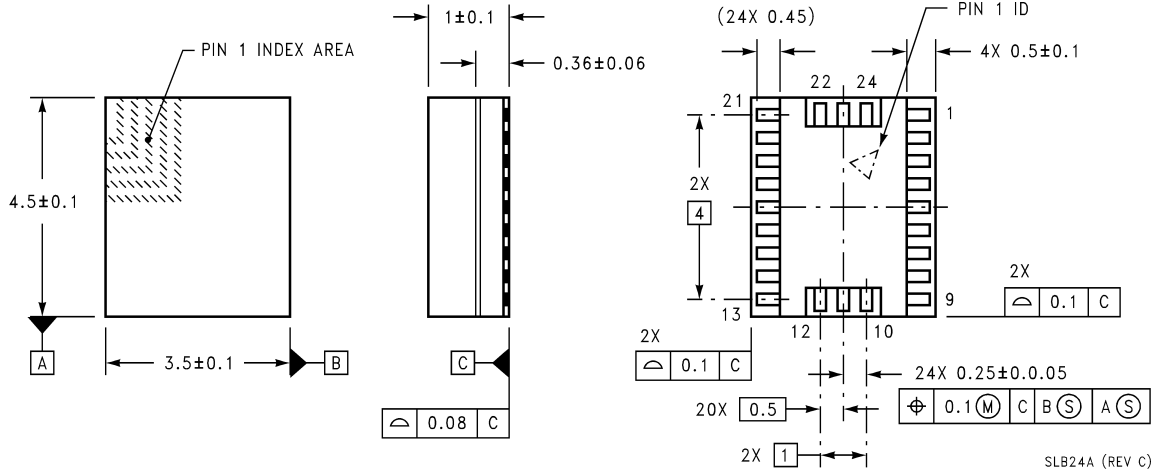

SLB24A (REV C)

24-Pin Chip Scale Package
For Tape and Reel (2500 Units per Reel)
Order Number LMX2330LSLBX, LMX2331LSLBX or LMX2332LSLBX
NS Package Number SLB24A

Physical Dimensions inches (millimeters) unless otherwise noted (Continued)

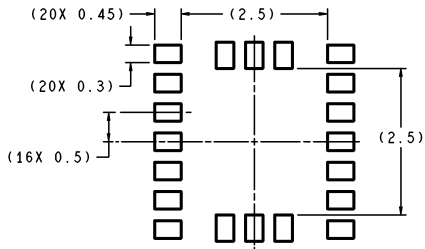

DIMENSIONS ARE IN MILLIMETERS

RECOMMENDED LAND PATTERN
1:1 RATIO WITH PACKAGE SOLDER PADS

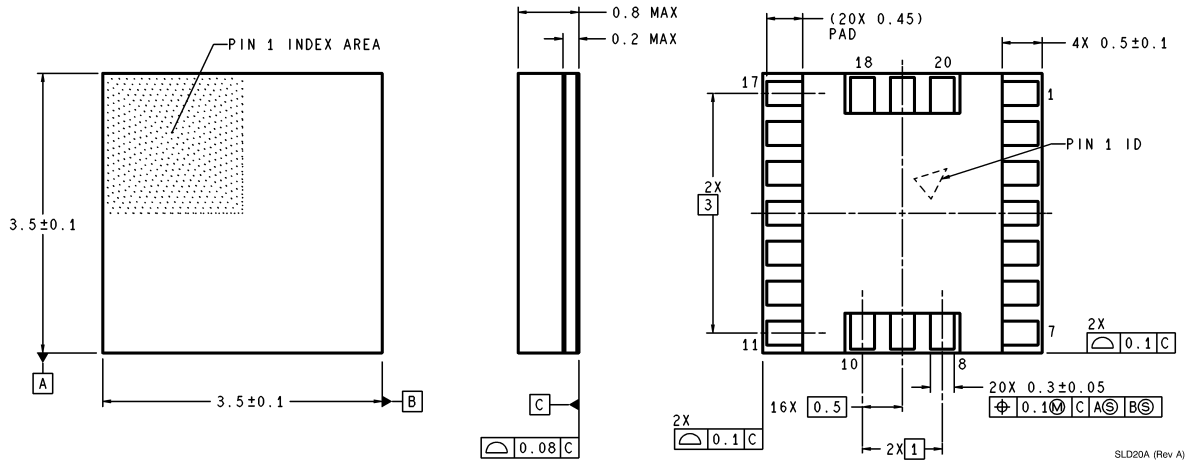

SLD20A (Rev A)

20-Pin Thin Chip Scale Package (SLD)
Order Number LMX2330LSLDX, LMX2331LSLDX or LMX2332LSLDX
NS Package Number SLD20A

LIFE SUPPORT POLICY

NATIONAL'S PRODUCTS ARE NOT AUTHORIZED FOR USE AS CRITICAL COMPONENTS IN LIFE SUPPORT DEVICES OR SYSTEMS WITHOUT THE EXPRESS WRITTEN APPROVAL OF THE PRESIDENT AND GENERAL COUNSEL OF NATIONAL SEMICONDUCTOR CORPORATION. As used herein:

1. Life support devices or systems are devices or systems which, (a) are intended for surgical implant into the body, or (b) support or sustain life, and whose failure to perform when properly used in accordance with instructions for use provided in the labeling, can be reasonably expected to result in a significant injury to the user.
2. A critical component is any component of a life support device or system whose failure to perform can be reasonably expected to cause the failure of the life support device or system, or to affect its safety or effectiveness.



National Semiconductor Corporation
Americas
Email: support@nsc.com

National Semiconductor Europe
Fax: +49 (0) 180-530 85 86
Email: europe.support@nsc.com
Deutsch Tel: +49 (0) 69 9508 6208
English Tel: +44 (0) 870 24 0 2171
Français Tel: +33 (0) 1 41 91 8790

National Semiconductor Asia Pacific Customer Response Group
Tel: 65-2544466
Fax: 65-2504466
Email: ap.support@nsc.com

National Semiconductor Japan Ltd.
Tel: 81-3-5639-7560
Fax: 81-3-5639-7507

www.national.com