

## 200MHz Rail-to-Rail Amplifiers



The EL8200, EL8201, and EL8401 represent rail-to-rail amplifiers with a -3dB bandwidth of 200MHz and slew

rate of 200V/μs. Running off a very low supply current of 2mA per channel, the EL8200, EL8201, and EL8401 also feature inputs that go to 0.15V below the  $V_{S-}$  rail. The EL8200 and EL8201 are dual channel amplifiers. The EL8401 is a quad channel amplifier.

The EL8200 includes a fast-acting disable/power-down circuit. With a 25ns disable and a 200ns enable, the EL8200 is ideal for multiplexing applications.

The EL8200, EL8201, and EL8401 are designed for a number of general purpose video, communication, instrumentation, and industrial applications. The EL8200 is available in a 10-pin MSOP package, the EL8201 in an 8-pin SO package, and the EL8401 in a 14-pin SO and 16-pin QSOP packages. All are specified for operation over the -40°C to +85°C temperature range.

## Ordering Information

PART NUMBER	PACKAGE	TAPE & REEL	PKG. DWG. #
EL8200Y	10-Pin MSOP	-	MDP0043
EL8200Y-T7	10-Pin MSOP	7"	MDP0043
EL8200Y-T13	10-Pin MSOP	13"	MDP0043
EL8201IS	8-Pin SO	-	MDP0027
EL8201IS-T7	8-Pin SO	7"	MDP0027
EL8201IS-T13	8-Pin SO	13"	MDP0027
EL8201ISZ (See Note)	8-Pin SO (Pb-free)	-	MDP0027
EL8201ISZ-T7 (See Note)	8-Pin SO (Pb-free)	7"	MDP0027
EL8201ISZ-T13 (See Note)	8-Pin SO (Pb-free)	13"	MDP0027
EL8401IS	14-Pin SO	-	MDP0027
EL8401IS-T7	14-Pin SO	7"	MDP0027
EL8401IS-T13	14-Pin SO	13"	MDP0027
EL8401ISZ (See Note)	14-Pin SO (Pb-free)	-	MDP0027
EL8401ISZ-T7 (See Note)	14-Pin SO (Pb-free)	7"	MDP0027
EL8401ISZ-T13 (See Note)	14-Pin SO (Pb-free)	13"	MDP0027
EL8401IU	16-Pin QSOP	-	MDP0040
EL8401IU-T7	16-Pin QSOP	7"	MDP0040
EL8401IU-T13	16-Pin QSOP	13"	MDP0040

NOTE: Intersil Pb-free products employ special Pb-free material sets; molding compounds/die attach materials and 100% matte tin plate termination finish, which is compatible with both SnPb and Pb-free soldering operations. Intersil Pb-free products are MSL classified at Pb-free peak reflow temperatures that meet or exceed the Pb-free requirements of IPC/JEDEC J Std-020B.

## Features

- 200MHz -3dB bandwidth
- 200V/μs slew rate
- Low supply current = 2mA per channel
- Supplies from 3V to 5.5V
- Rail-to-rail output
- Input to 0.15V below  $V_{S-}$
- Fast 25ns disable (EL8200 only)
- Low cost
- Pb-free available

## Applications

- Video amplifiers
- Portable/hand-held products
- Communications devices

Pinouts

EL8201  
(8-PIN SO)  
TOP VIEW

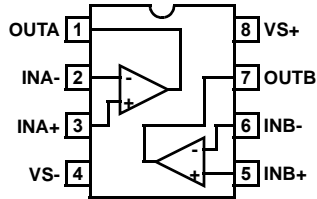

EL8200  
(10-PIN MSOP)  
TOP VIEW

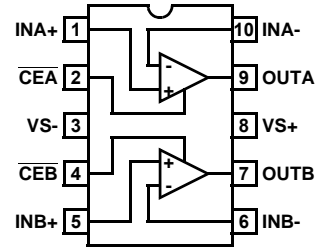

EL8401  
(14-PIN SO)  
TOP VIEW

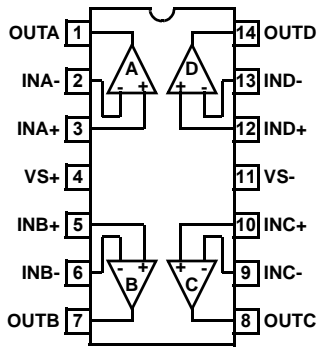

EL8401  
(16-PIN QSOP)  
TOP VIEW

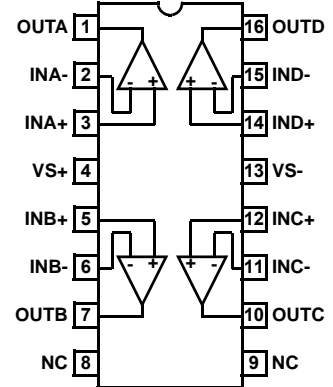

## EL8200, EL8201, EL8401

### Absolute Maximum Ratings ( $T_A = 25^\circ\text{C}$ )

Supply Voltage from $V_{S+}$ to $V_{S-}$ . . . . . 5.5V	Power Dissipation . . . . . See Curves
Input Voltage . . . . . $V_{S+} + 0.3\text{V}$ to $V_{S-} - 0.3\text{V}$	Storage Temperature . . . . . $-65^\circ\text{C}$ to $+150^\circ\text{C}$
Differential Input Voltage . . . . . $\pm 2\text{V}$	Ambient Operating Temperature . . . . . $-40^\circ\text{C}$ to $+85^\circ\text{C}$
Continuous Output Current . . . . . 40mA	Operating Junction Temperature . . . . . $+125^\circ\text{C}$

*CAUTION: Stresses above those listed in "Absolute Maximum Ratings" may cause permanent damage to the device. This is a stress only rating and operation of the device at these or any other conditions above those indicated in the operational sections of this specification is not implied.*

**IMPORTANT NOTE:** All parameters having Min/Max specifications are guaranteed. Typ values are for information purposes only. Unless otherwise noted, all tests are at the specified temperature and are pulsed tests, therefore:  $T_J = T_C = T_A$

### Electrical Specifications $V_{S+} = 5\text{V}$ , $V_{S-} = \text{GND}$ , $T_A = 25^\circ\text{C}$ , $V_{CM} = 2.5\text{V}$ , $R_L$ to $2.5\text{V}$ , $A_V = 1$ , Unless Otherwise Specified

PARAMETER	DESCRIPTION	CONDITIONS	MIN	TYP	MAX	UNIT
<b>INPUT CHARACTERISTICS</b>						
$V_{OS}$	Offset Voltage		-6	-0.8	+6	mV
$TCV_{OS}$	Offset Voltage Temperature Coefficient	Measured from $T_{MIN}$ to $T_{MAX}$		3		$\mu\text{V}/^\circ\text{C}$
$I_B$	Input Bias Current	$V_{IN} = 0\text{V}$	-2.5	-1.6		$\mu\text{A}$
$I_{OS}$	Input Offset Current	$V_{IN} = 0\text{V}$		0.2	0.55	$\mu\text{A}$
$TCI_{OS}$	Input Bias Current Temperature Coefficient	Measured from $T_{MIN}$ to $T_{MAX}$		2		$\text{nA}/^\circ\text{C}$
$CMRR$	Common Mode Rejection Ratio	$V_{CM} = -0.15\text{V}$ to $+3.5\text{V}$ (EL8200,EL8201)	70	90		dB
		$V_{CM} = -0.15\text{V}$ to $+3.5\text{V}$ (EL8401)	65	90		dB
$CMIR$	Common Mode Input Range		$V_{S-} - 0.15$		$V_{S+} - 1.5$	V
$R_{IN}$	Input Resistance	Common Mode		16		$\text{M}\Omega$
$C_{IN}$	Input Capacitance			0.5		pF
$A_{VOL}$	Open Loop Gain	$V_{OUT} = +1.5\text{V}$ to $+3.5\text{V}$ , $R_L = 1\text{k}\Omega$ to GND	75	90		dB
		$V_{OUT} = +1.5\text{V}$ to $+3.5\text{V}$ , $R_L = 150\Omega$ to GND		80		dB
<b>OUTPUT CHARACTERISTICS</b>						
$R_{OUT}$	Output Resistance	$A_V = +1$		30		$\text{m}\Omega$
$V_{OP}$	Positive Output Voltage Swing	$R_L = 1\text{k}\Omega$	4.85	4.9		V
		$R_L = 150\Omega$	4.6	4.7		V
$V_{ON}$	Negative Output Voltage Swing	$R_L = 150\Omega$		100	150	mV
		$R_L = 1\text{k}\Omega$		35	50	mV
$I_{OUT}$	Linear Output Current			65		mA
$I_{SC}(\text{source})$	Short Circuit Current	$R_L = 10\Omega$	60	70		mA
$I_{SC}(\text{sink})$	Short Circuit Current	$R_L = 10\Omega$	100	130		mA
<b>POWER SUPPLY</b>						
$PSRR$	Power Supply Rejection Ratio	$V_{S+} = 4.5\text{V}$ to $5.5\text{V}$	70	100		dB
$I_{S-ON}$	Supply Current - Enabled per Amplifier			2	2.4	mA
$I_{S-OFF}$	Supply Current - Disabled per Amplifier			40	90	$\mu\text{A}$
<b>ENABLE (EL8200 ONLY)</b>						
$t_{EN}$	Enable Time			200		ns

## EL8200, EL8201, EL8401

### Electrical Specifications $V_{S+} = 5V$ , $V_{S-} = GND$ , $T_A = 25^\circ C$ , $V_{CM} = 2.5V$ , $R_L$ to 2.5V, $A_V = 1$ , Unless Otherwise Specified (Continued)

PARAMETER	DESCRIPTION	CONDITIONS	MIN	TYP	MAX	UNIT
$t_{DS}$	Disable Time			25		ns
$V_{IH-ENB}$	$\overline{ENABLE}$ Pin Voltage for Power-up			0.8		V
$V_{IL-ENB}$	$\overline{ENABLE}$ Pin Voltage for Shut-down			2		V
$I_{IH-ENB}$	$\overline{ENABLE}$ Pin Input Current High			8.6		$\mu A$
$I_{IL-ENB}$	$\overline{ENABLE}$ Pin Input for Current Low			0.01		$\mu A$
<b>AC PERFORMANCE</b>						
BW	-3dB Bandwidth	$A_V = +1$ , $R_F = 0\Omega$ , $C_L = 1.5pF$		200		MHz
		$A_V = -1$ , $R_F = 1k\Omega$ , $C_L = 1.5pF$		90		MHz
		$A_V = +2$ , $R_F = 1k\Omega$ , $C_L = 1.5pF$		90		MHz
		$A_V = +10$ , $R_F = 1k\Omega$ , $C_L = 1.5pF$		10		MHz
BW	$\pm 0.1dB$ Bandwidth	$A_V = +1$ , $R_F = 0\Omega$ , $C_L = 1.5pF$		20		MHz
Peak	Peaking	$A_V = +1$ , $R_F = 1k\Omega$ , $C_L = 1.5pF$		1		dB
GBWP	Gain Bandwidth Product			100		MHz
PM	Phase Margin	$R_L = 1k\Omega$ , $C_L = 1.5pF$		55		$^\circ$
SR	Slew Rate	$A_V = 2$ , $R_L = 100\Omega$ , $V_{OUT} = 0.5V$ to 4.5V	160	200		V/ $\mu s$
$t_R$	Rise Time	$2.5V_{STEP}$ , 20% - 80%		8		ns
$t_F$	Fall Time	$2.5V_{STEP}$ , 20% - 80%		7		ns
OS	Overshoot	200mV step		10		%
$t_{PD}$	Propagation Delay	200mV step		2		ns
$t_S$	0.1% Settling Time	200mV step		20		ns
dG	Differential Gain	$A_V = +2$ , $R_F = 1k\Omega$ , $R_L = 150\Omega$		0.035		%
dP	Differential Phase	$A_V = +2$ , $R_F = 1k\Omega$ , $R_L = 150\Omega$		0.05		$^\circ$
$e_N$	Input Noise Voltage	$f = 10kHz$		10		nV/ $\sqrt{Hz}$
$i_{N+}$	Positive Input Noise Current	$f = 10kHz$		1		pA/ $\sqrt{Hz}$
$i_{N-}$	Negative Input Noise Current	$f = 10kHz$		0.8		pA/ $\sqrt{Hz}$
$e_S$	Channel Separation	$f = 100kHz$		95		dB

### Pin Descriptions

EL8200	EL8201	EL8401 (SO-14)	EL8401 (QSOP-16)	NAME	FUNCTION
1, 5	3, 5	3, 5, 10, 12	3,5,12,14	IN+	Non-inverting input for each channel
2, 4				$\overline{CE}$	Enable and disable input for each channel
3	4	11	13	VS-	Negative power supply
6, 10	2, 6	2, 6, 9, 13	2,6,11,15	IN-	Inverting input for each channel
7, 9	1, 7	1, 7, 8, 14	1,7,10,16	OUT	Amplifier output for each channel
8	8	4	4	VS+	Positive power supply

Typical Performance Curves

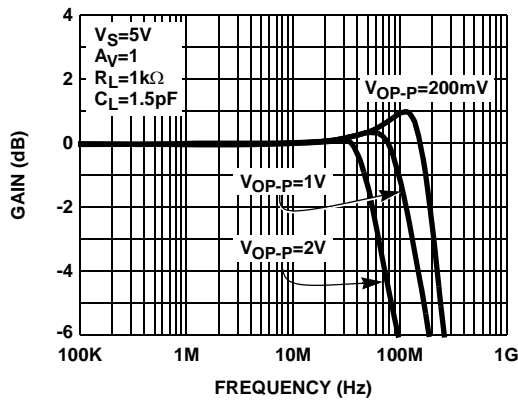

FIGURE 1. FREQUENCY RESPONSE FOR VARIOUS OUTPUT VOLTAGE LEVELS

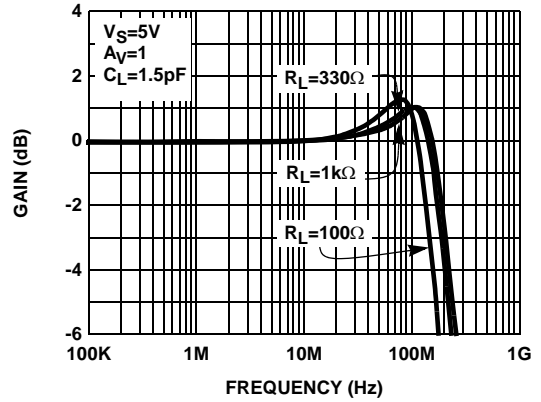

FIGURE 2. SMALL SIGNAL FREQUENCY RESPONSE FOR VARIOUS  $R_{LOAD}$

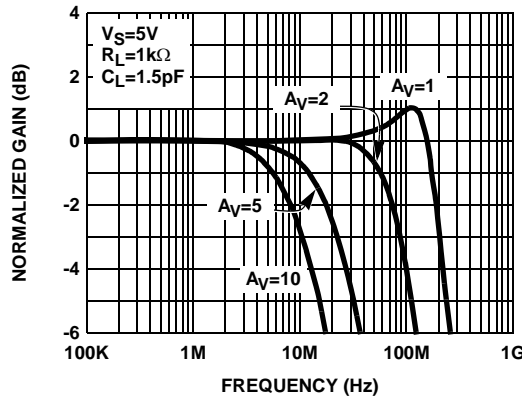

FIGURE 3. SMALL SIGNAL FREQUENCY RESPONSE FOR VARIOUS NON-INVERTING GAINS

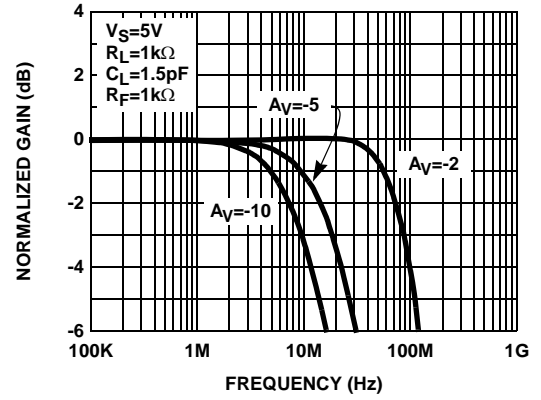

FIGURE 4. SMALL SIGNAL FREQUENCY RESPONSE FOR VARIOUS INVERTING GAINS

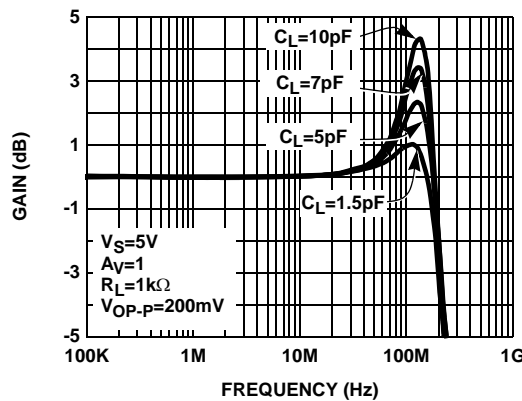

FIGURE 5. SMALL SIGNAL FREQUENCY RESPONSE FOR VARIOUS  $C_L$

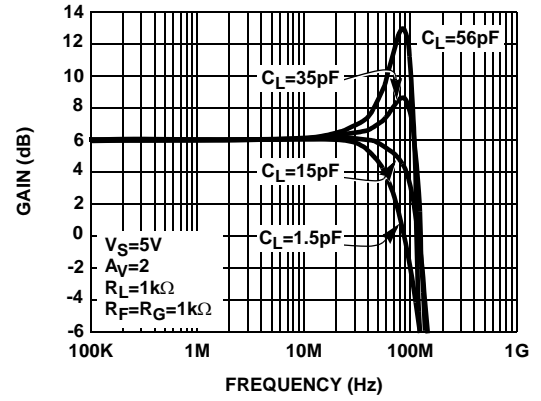

FIGURE 6. SMALL SIGNAL FREQUENCY RESPONSE FOR VARIOUS  $C_L$

Typical Performance Curves (Continued)

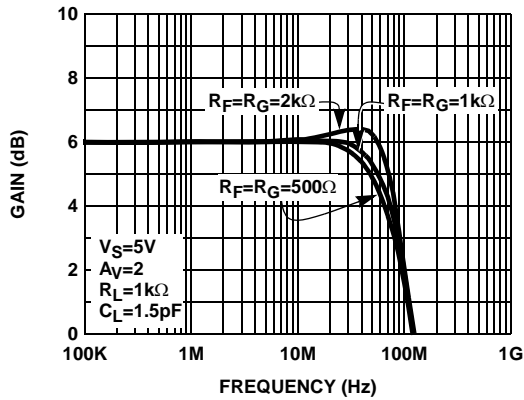

FIGURE 7. SMALL SIGNAL FREQUENCY RESPONSE FOR VARIOUS  $R_F$  AND  $R_G$

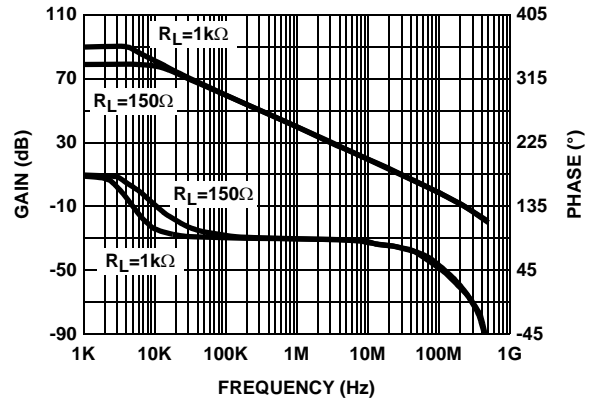

FIGURE 8. OPEN LOOP GAIN AND PHASE vs FREQUENCY

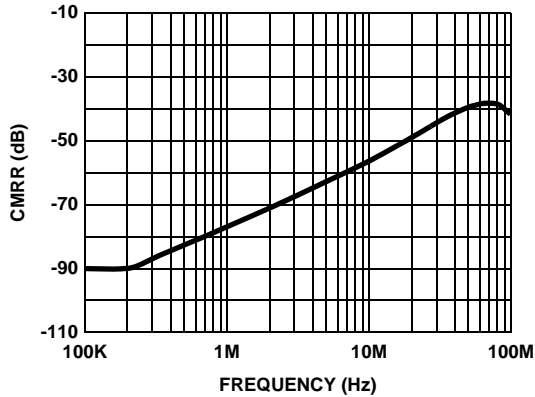

FIGURE 9. COMMON-MODE REJECTION RATIO vs FREQUENCY

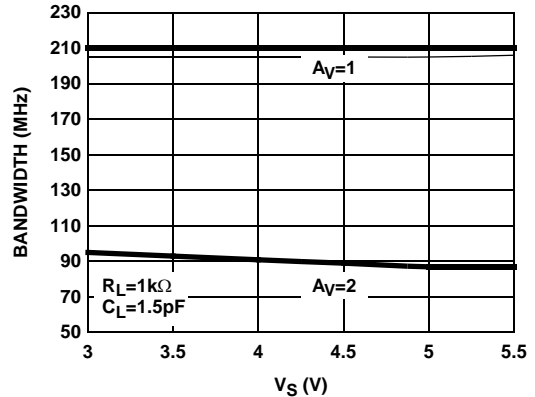

FIGURE 10. SMALL SIGNAL BANDWIDTH vs SUPPLY VOLTAGE

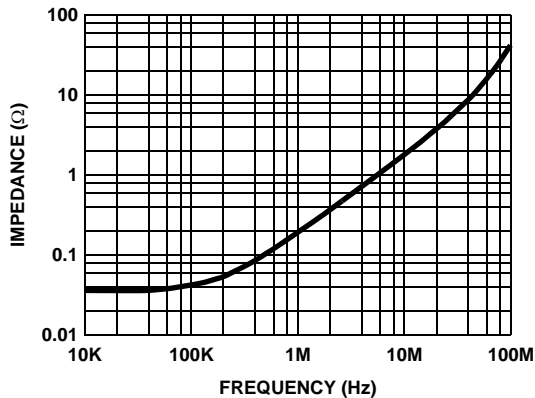

FIGURE 11. OUTPUT IMPEDANCE vs FREQUENCY

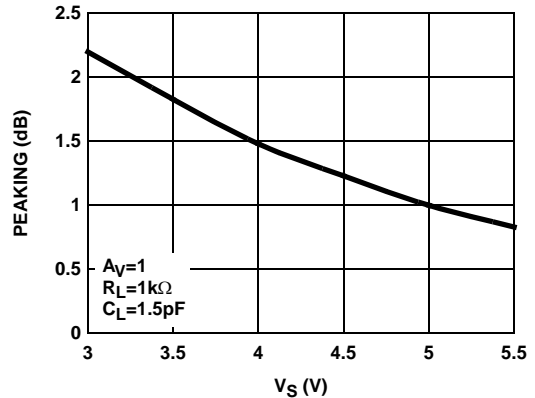

FIGURE 12. SMALL SIGNAL PEAKING vs SUPPLY VOLTAGE

Typical Performance Curves (Continued)

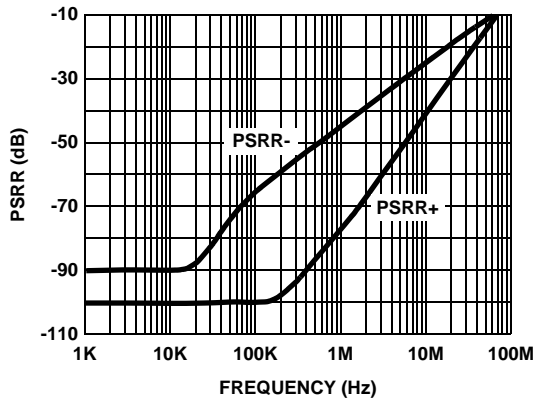

FIGURE 13. POWER SUPPLY REJECTION RATIO vs FREQUENCY

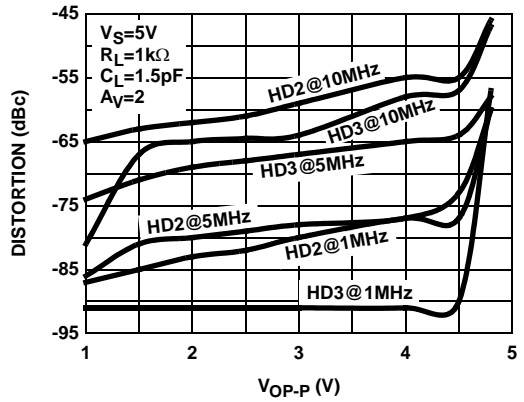

FIGURE 14. HARMONIC DISTORTION vs OUTPUT VOLTAGE

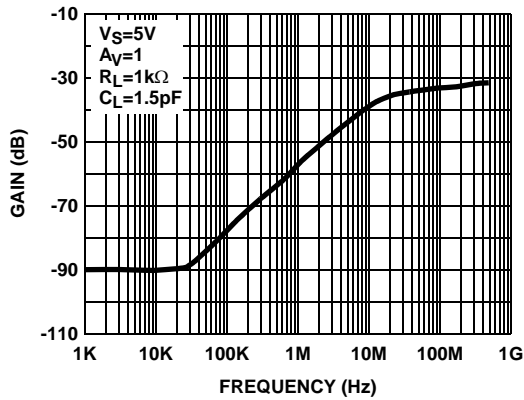

FIGURE 15. DISABLED OUTPUT ISOLATION FREQUENCY RESPONSE

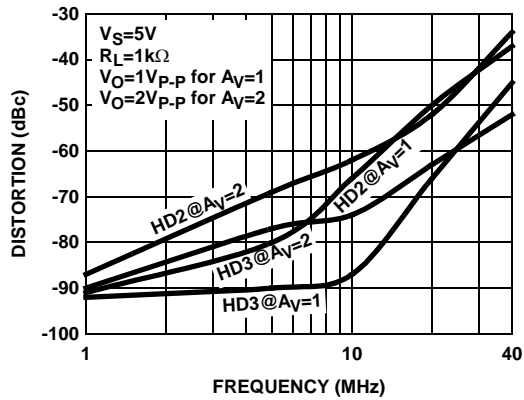

FIGURE 16. HARMONIC DISTORTION vs FREQUENCY

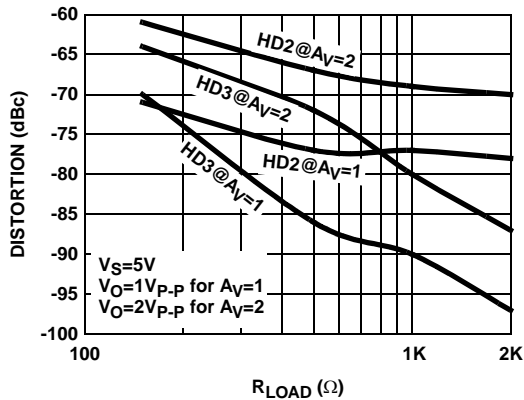

FIGURE 17. HARMONIC DISTORTION vs LOAD RESISTANCE

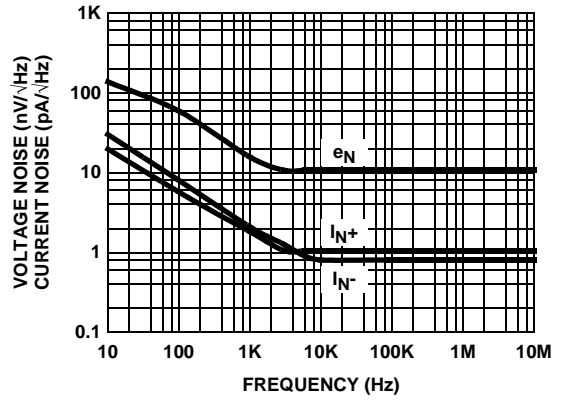

FIGURE 18. VOLTAGE AND CURRENT NOISE vs FREQUENCY

Typical Performance Curves (Continued)

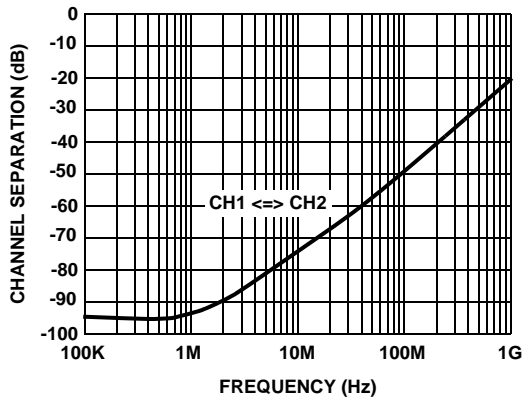

FIGURE 19. CHANNEL SEPARATION vs FREQUENCY (EL8200 AND EL8201)

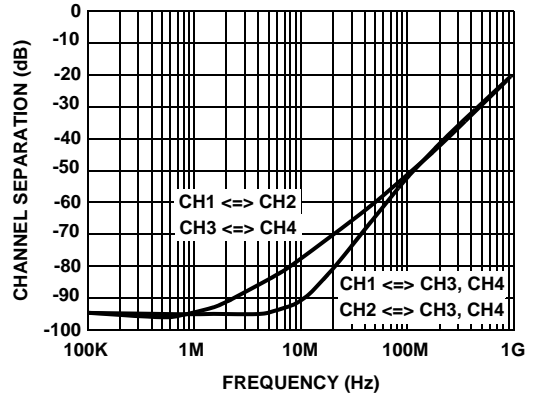

FIGURE 20. CHANNEL SEPARATION vs FREQUENCY (EL8401)

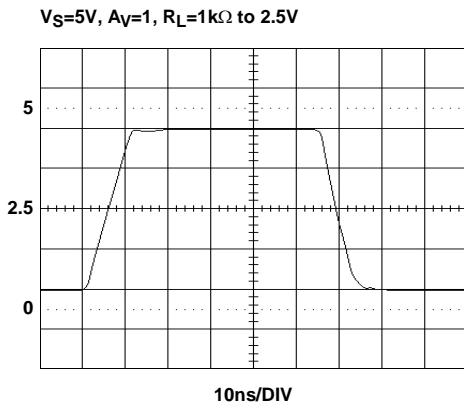

FIGURE 21. LARGE SIGNAL TRANSIENT RESPONSE

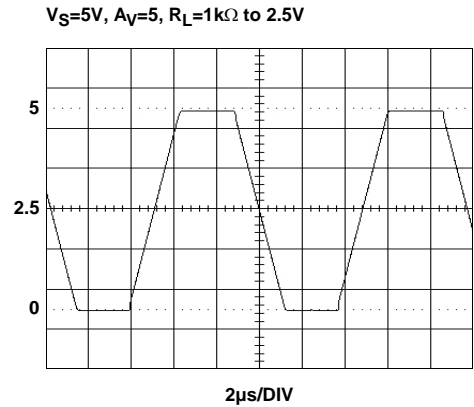

FIGURE 22. OUTPUT SWING

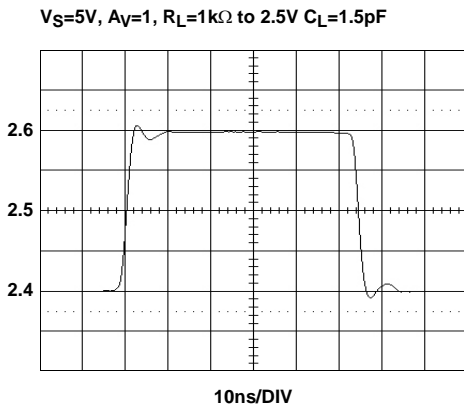

FIGURE 23. SMALL SIGNAL TRANSIENT RESPONSE

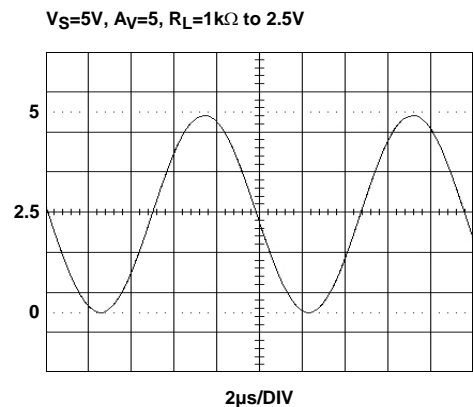

FIGURE 24. OUTPUT SWING



Typical Performance Curves (Continued)

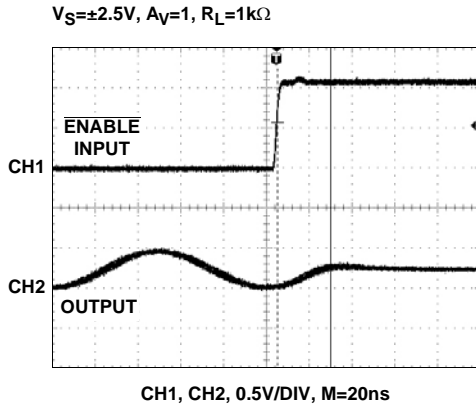

FIGURE 25. DISABLED RESPONSE (EL8200)

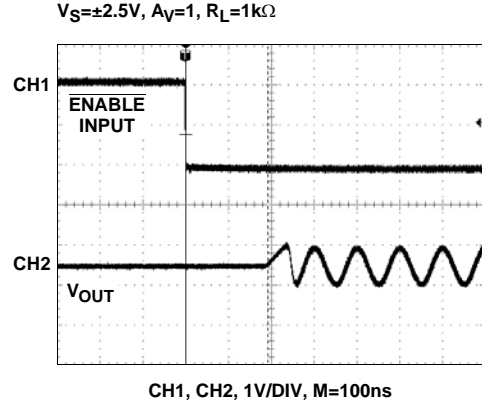

FIGURE 26. ENABLED RESPONSE (EL8200)

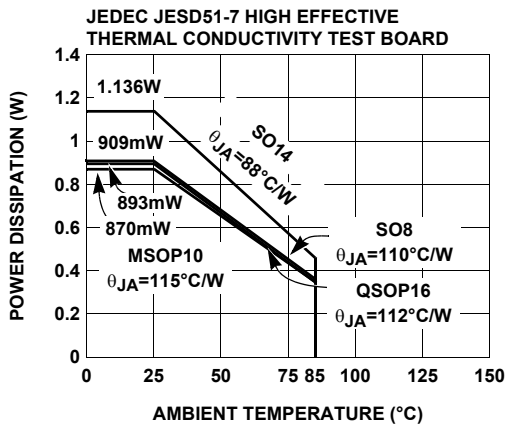

FIGURE 27. PACKAGE POWER DISSIPATION vs AMBIENT TEMPERATURE

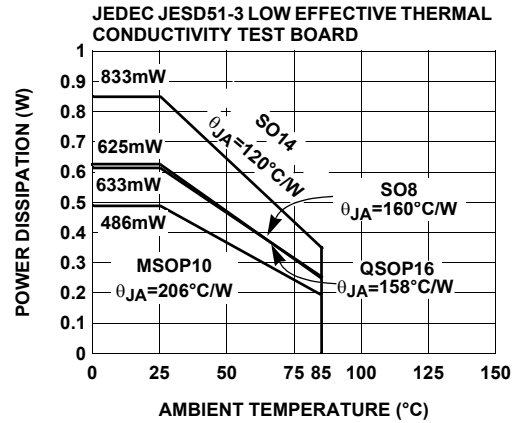
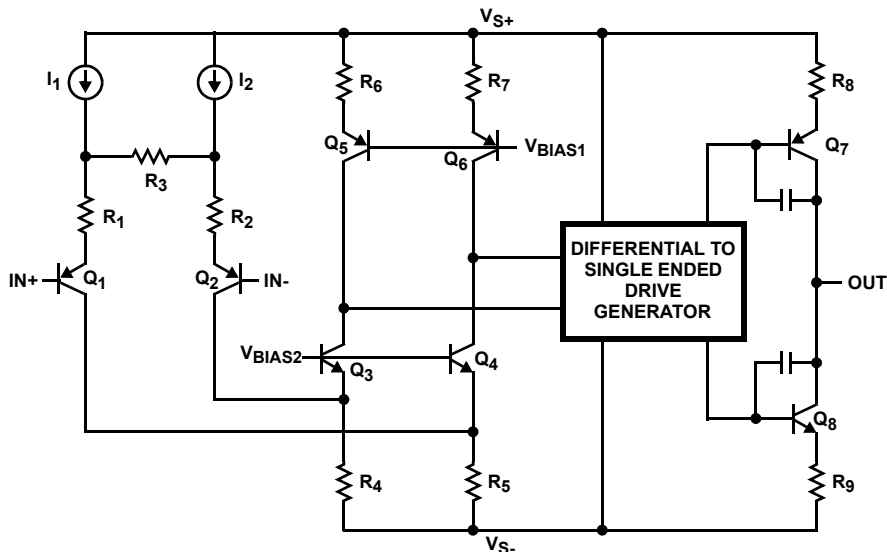

FIGURE 28. PACKAGE POWER DISSIPATION vs AMBIENT TEMPERATURE

Simplified Schematic Diagram



## **Description of Operation and Application Information**

### **Product Description**

The EL8200, EL8201 and EL8401 are wide bandwidth, single supply, low power and rail-to-rail output voltage feedback operational amplifiers. The amplifiers are internally compensated for closed loop gain of +1 or greater. Connected in voltage follower mode and driving a 1kΩ load, they have a -3dB bandwidth of 200MHz. Driving a 150Ω load, the bandwidth is about 130MHz while maintaining a 200V/us slew rate. The EL8200 is available with a power down pin to reduce power to 30μA typically while the amplifier is disabled.

### **Input, Output and Supply Voltage Range**

The EL8200, EL8201 and EL8401 have been designed to operate with a single supply voltage from 3V to 5.0V. Split supplies can also be used as long as their total voltage is within 3V to 5.0V. The amplifiers have an input common mode voltage range from 0.15V below the negative supply ( $V_{S-}$  pin) to within 1.5V of the positive supply ( $V_{S+}$  pin). If the input signal is outside the above specified range, it will cause the output signal to be distorted.

The output of the EL8200, EL8201 and EL8401 can swing rail to rail. As the load resistance becomes lower, the ability to drive close to each rail is reduced. For the load resistor 1kΩ, the output swing is about 4.9V at a 5V supply. For the load resistor 150Ω, the output swing is about 4.6V.

### **Choice of Feedback Resistor and Gain Bandwidth Product**

For applications that require a gain of +1, no feedback resistor is required. Just short the output pin to the inverting input pin. For gains greater than +1, the feedback resistor forms a pole with the parasitic capacitance at the inverting input. As this pole becomes smaller, the amplifier's phase margin is reduced. This causes ringing in the time domain and peaking in the frequency domain. Therefore,  $R_F$  has some maximum value that should not be exceeded for optimum performance. If a large value of  $R_F$  must be used, a small capacitor in the few Pico farad range in parallel with  $R_F$  can help to reduce the ringing and peaking at the expense of reducing the bandwidth.

As far as the output stage of the amplifier is concerned, the output stage is also a gain stage with the load.  $R_F$  and  $R_G$  appear in parallel with  $R_L$  for gains other than +1. As this combination gets smaller, the bandwidth falls off. Consequently,  $R_F$  also has a minimum value that should not be exceeded for optimum performance. For gain of +1,  $R_F=0$  is optimum. For the gains other than +1, optimum response is obtained with  $R_F$  between 300Ω to 1kΩ.

The EL8200, EL8201 and EL8401 have a gain bandwidth product of 100MHz. For gains  $\geq 5$ , its bandwidth can be predicted by the following equation:

$$\text{Gain} \times \text{BW} = 100\text{MHz}$$

### **Video Performance**

For good video performance, an amplifier is required to maintain the same output impedance and the same frequency response as DC levels are changed at the output. This is especially difficult when driving a standard video load of 150Ω, because the change in output current with DC level. Special circuitry has been incorporated in the EL8200, EL8201 and EL8401 to reduce the variation of the output impedance with the current output. This results in dG and dP specifications of 0.03% and 0.05°, while driving 150Ω at a gain of 2. Driving high impedance loads would give a similar or better dG and dP performance.

### **Driving Capacitive Loads and Cables**

The EL8200, EL8201 and EL8401 can drive 10pF loads in parallel with 1kΩ with less than 5dB of peaking at gain of +1. If less peaking is desired in applications, a small series resistor (usually between 5Ω to 50Ω) can be placed in series with the output to eliminate most peaking. However, this will reduce the gain slightly. If the gain setting is greater than 1, the gain resistor  $R_G$  can then be chosen to make up for any gain loss which may be created by the additional series resistor at the output.

When used as a cable driver, double termination is always recommended for reflection-free performance. For those applications, a back-termination series resistor at the amplifier's output will isolate the amplifier from the cable and allow extensive capacitive drive. However, other applications may have high capacitive loads without a back-termination resistor. Again, a small series resistor at the output can help to reduce peaking.

### **Disable/Power-Down**

The EL8200 can be disabled and placed its output in a high impedance state. The turn off time for each channel is about 25ns and the turn on time is about 200ns. When disabled, the amplifier's supply current is reduced to 30μA typically, thereby effectively eliminating the power consumption. The amplifier's power down can be controlled by standard TTL or CMOS signal levels at the  $\overline{\text{ENABLE}}$  pin. The applied logic signal is relative to  $V_{S-}$  pin. Letting the  $\overline{\text{ENABLE}}$  pin float or applying a signal that is less than 0.8V above  $V_{S-}$  will enable the amplifier. The amplifier will be disabled when the signal at  $\overline{\text{ENABLE}}$  pin is 2V above  $V_{S-}$ .

### **Output Drive Capability**

The EL8200, EL8201 and EL8401 do not have internal short circuit protection circuitry. They have a typical short circuit current of 70mA sourcing and 140mA sinking for the output is connected to half way between the rails with a 10Ω resistor. If the output is shorted indefinitely, the power

dissipation could easily increase such that the part will be destroyed. Maximum reliability is maintained if the output current never exceeds  $\pm 40\text{mA}$ . This limit is set by the design of the internal metal interconnections.

### Power Dissipation

With the high output drive capability of the EL8200, EL8201 and EL8401, it is possible to exceed the  $125^\circ\text{C}$  absolute maximum junction temperature under certain load current conditions. Therefore, it is important to calculate the maximum junction temperature for the application to determine if the load conditions or package types need to be modified for the amplifier to remain in the safe operating area.

The maximum power dissipation allowed in a package is determined according to:

$$PD_{MAX} = \frac{T_{JMAX} - T_{AMAX}}{\theta_{JA}}$$

Where:

$T_{JMAX}$  = Maximum junction temperature

$T_{AMAX}$  = Maximum ambient temperature

$\theta_{JA}$  = Thermal resistance of the package

The maximum power dissipation actually produced by an IC is the total quiescent supply current times the total power supply voltage, plus the power in the IC due to the load, or:

For sourcing:

$$PD_{MAX} = V_S \times I_{SMAX} + \sum (V_S - V_{OUTi}) \times \frac{V_{OUTi}}{R_{Li}}$$

For sinking:

$$PD_{MAX} = V_S \times I_{SMAX} + \sum (V_{OUTi} - V_{S-}) \times I_{LOADi}$$

Where:

$V_S$  = Total supply voltage

$I_{SMAX}$  = Maximum quiescent supply current

$V_{OUTi}$  = Maximum output voltage of the application for each channel

$R_{LOADi}$  = Load resistance tied to ground for each channel

$I_{LOADi}$  = Load current for each channel

By setting the two  $PD_{MAX}$  equations equal to each other, we can solve the output current and  $R_{LOADi}$  to avoid the device overheat.

### Power Supply Bypassing and Printed Circuit Board Layout

As with any high frequency device, a good printed circuit board layout is necessary for optimum performance. Lead lengths should be as short as possible. The power supply pin must be well bypassed to reduce the risk of oscillation. For

normal single supply operation, where the  $V_{S-}$  pin is connected to the ground plane, a single  $4.7\mu\text{F}$  tantalum capacitor in parallel with a  $0.1\mu\text{F}$  ceramic capacitor from  $V_{S+}$  to GND will suffice. This same capacitor combination should be placed at each supply pin to ground if split supplies are to be used. In this case, the  $V_{S-}$  pin becomes the negative supply rail.

For good AC performance, parasitic capacitance should be kept to a minimum. Use of wire wound resistors should be avoided because of their additional series inductance. Use of sockets should also be avoided if possible. Sockets add parasitic inductance and capacitance that can result in compromised performance. Minimizing parasitic capacitance at the amplifier's inverting input pin is very important. The feedback resistor should be placed very close to the inverting input pin. Strip line design techniques are recommended for the signal traces.

### Typical Applications

#### VIDEO SYNC PULSE REMOVER

Many CMOS analog to digital converters have a parasitic latch up problem when subjected to negative input voltage levels. Since the sync tip contains no useful video information and it is a negative going pulse, we can chop it off. Figure 29 shows a gain of 2 connections. Figure 30 shows the complete input video signal applied at the input, as well as the output signal with the negative going sync pulse removed.

#### MULTIPLEXER

Besides the normal power down usage, the  $\overline{\text{ENABLE}}$  pin of the EL8200 can be used for multiplexing applications. Figure 31 shows two channels with the outputs tied together, driving a back terminated  $75\Omega$  video load. A  $2V_{P-P}$  2MHz sine wave is applied to Amp A and a  $1V_{P-P}$  2MHz sine wave is applied to Amp B. Figure 32 shows the  $\overline{\text{ENABLE}}$  signal and the resulting output waveform at  $V_{OUT}$ . Observe the break-before-make operation of the multiplexing. Amp A is on and  $V_{IN1}$  is passed through to the output when the  $\overline{\text{ENABLE}}$  signal is low and turns off in about 25ns when the  $\overline{\text{ENABLE}}$  signal is high. About 200ns later, Amp B turns on and  $V_{IN2}$  is passed through to the output. The break-before-make operation ensures that more than one amplifier isn't trying to drive the bus at the same time.

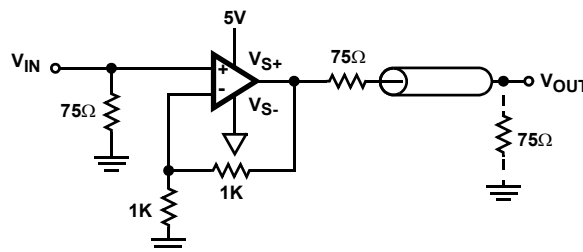

FIGURE 29. SYNC PULSE REMOVER

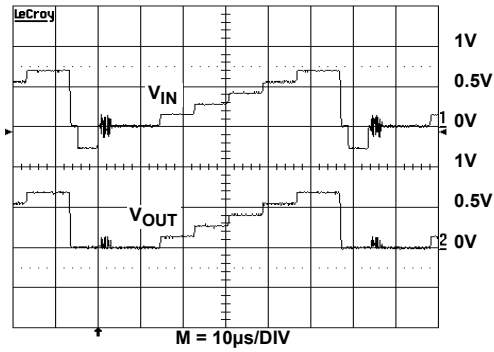

FIGURE 30. VIDEO SIGNAL

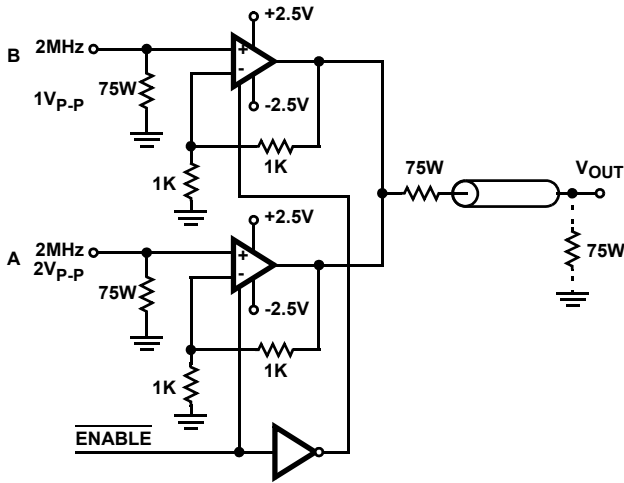

FIGURE 31. TWO TO ONE MULTIPLEXER

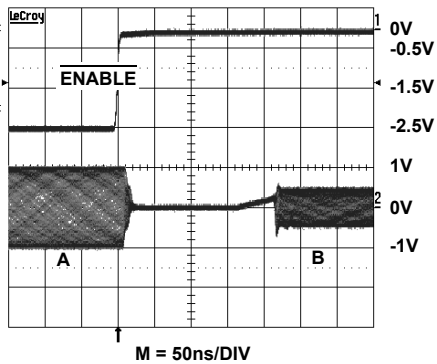

FIGURE 32. ENABLE SIGNAL

**SINGLE SUPPLY VIDEO LINE DRIVER**

The EL8200, EL8201 and EL8401 are wideband rail-to-rail output op amplifiers with large output current, excellent dG, dP, and low distortion that allow them to drive video signals in low supply applications. Figure 33 is the single supply non-inverting video line driver configuration and Figure 34 is the inverting video line driver configuration. The signal is AC coupled by C<sub>1</sub>. R<sub>1</sub> and R<sub>2</sub> are used to level shift the input and output to provide the largest output swing. R<sub>F</sub> and R<sub>G</sub>

set the AC gain. C<sub>2</sub> isolates the virtual ground potential. R<sub>T</sub> and R<sub>3</sub> are the termination resistors for the line. C<sub>1</sub>, C<sub>2</sub> and C<sub>3</sub> are selected big enough to minimize the droop of the luminance signal.

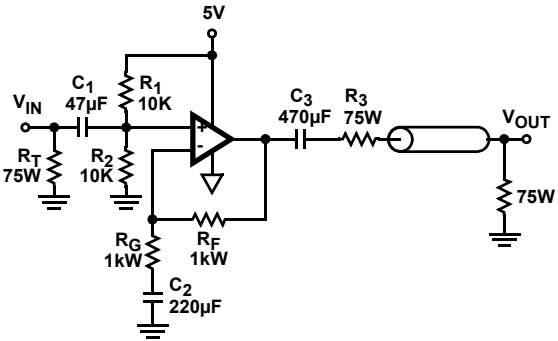

FIGURE 33. 5V SINGLE SUPPLY NON INVERTING VIDEO LINE DRIVER

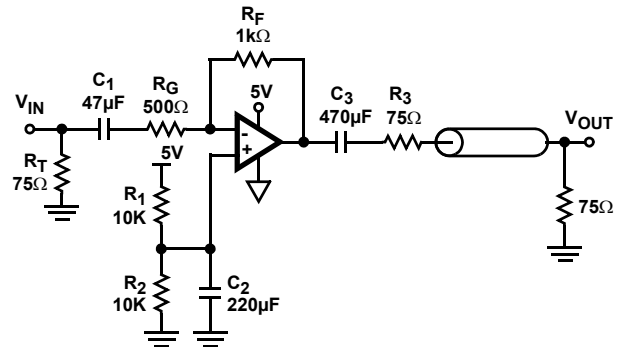

FIGURE 34. 5V SINGLE SUPPLY INVERTING VIDEO LINE DRIVER

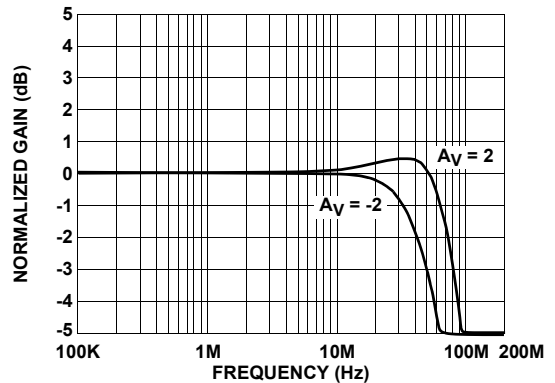
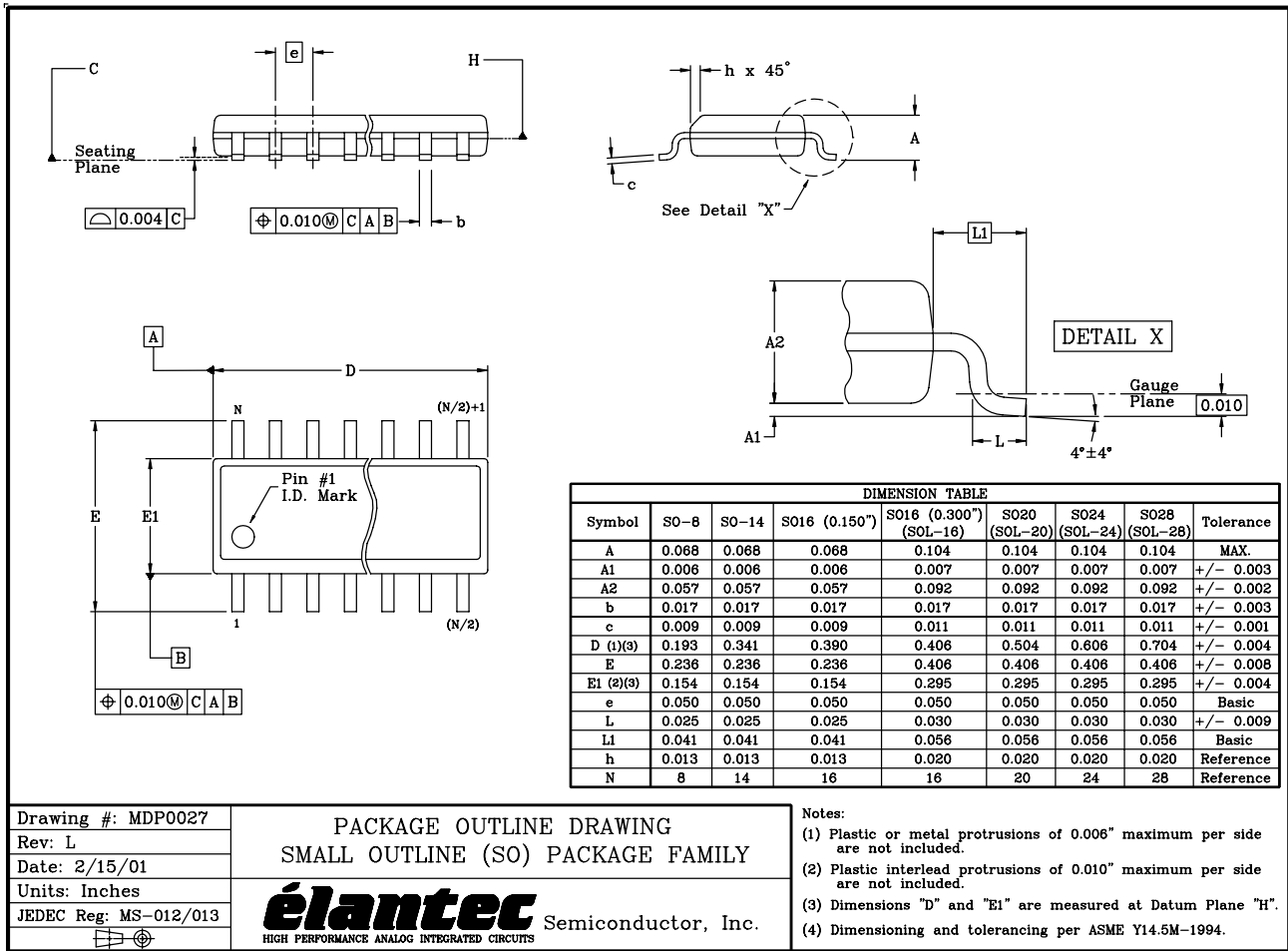

FIGURE 35. VIDEO LINE DRIVER FREQUENCY RESPONSE

SO Package Outline Drawing



Drawing #: MDP0027  
 Rev: L  
 Date: 2/15/01  
 Units: Inches  
 JEDEC Reg: MS-012/013

PACKAGE OUTLINE DRAWING  
 SMALL OUTLINE (SO) PACKAGE FAMILY

**élantec** Semiconductor, Inc.  
 HIGH PERFORMANCE ANALOG INTEGRATED CIRCUITS

Notes:  
 (1) Plastic or metal protrusions of 0.006" maximum per side are not included.  
 (2) Plastic interlead protrusions of 0.010" maximum per side are not included.  
 (3) Dimensions "D" and "E1" are measured at Datum Plane "H".  
 (4) Dimensioning and tolerancing per ASME Y14.5M-1994.

MSOP Package Outline Drawing

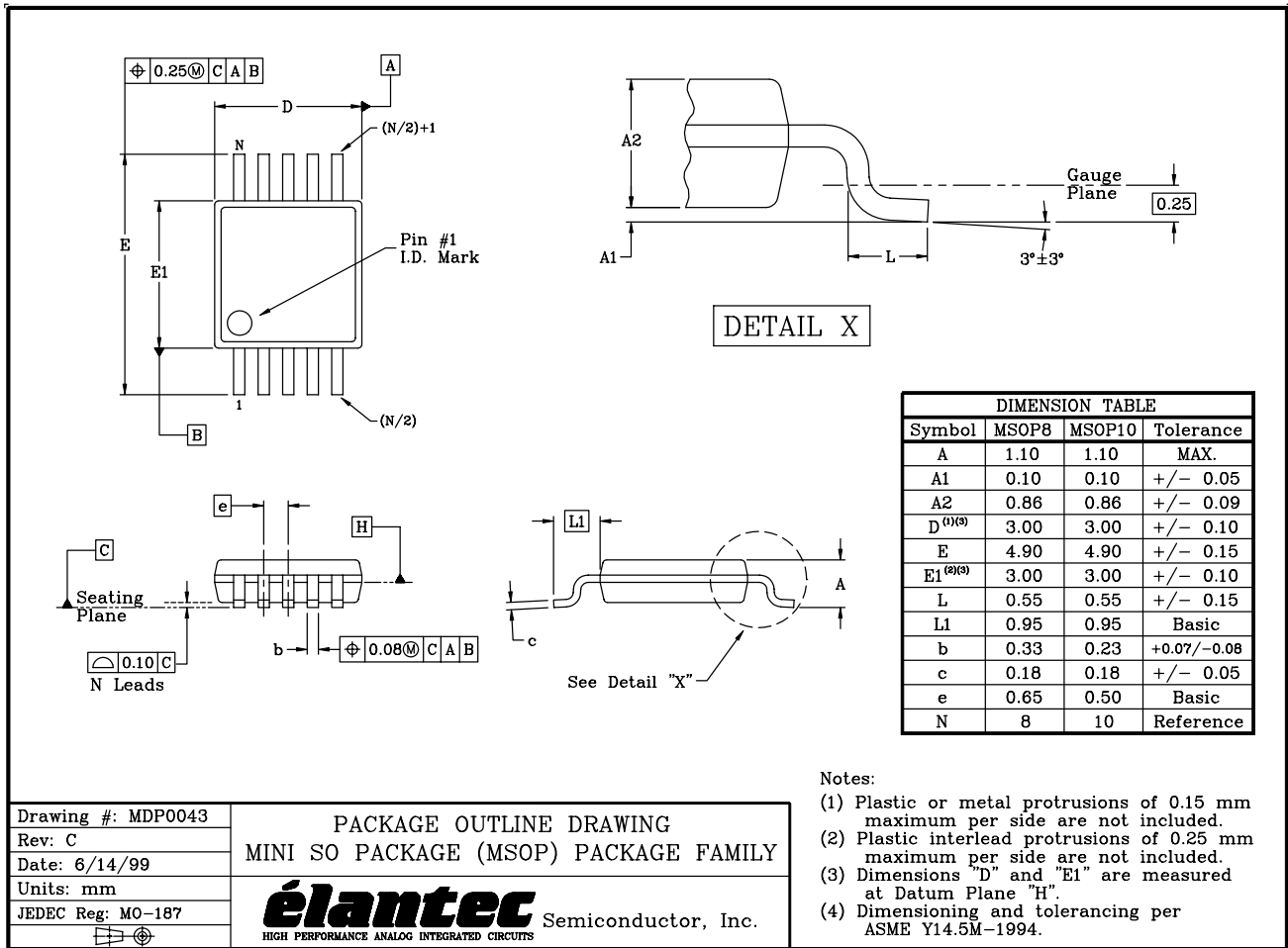

Drawing #: MDP0043 Rev: C Date: 6/14/99 Units: mm JEDEC Reg: MO-187	PACKAGE OUTLINE DRAWING MINI SO PACKAGE (MSOP) PACKAGE FAMILY  Semiconductor, Inc. HIGH PERFORMANCE ANALOG INTEGRATED CIRCUITS
---	---

QSOP Package Outline Drawing

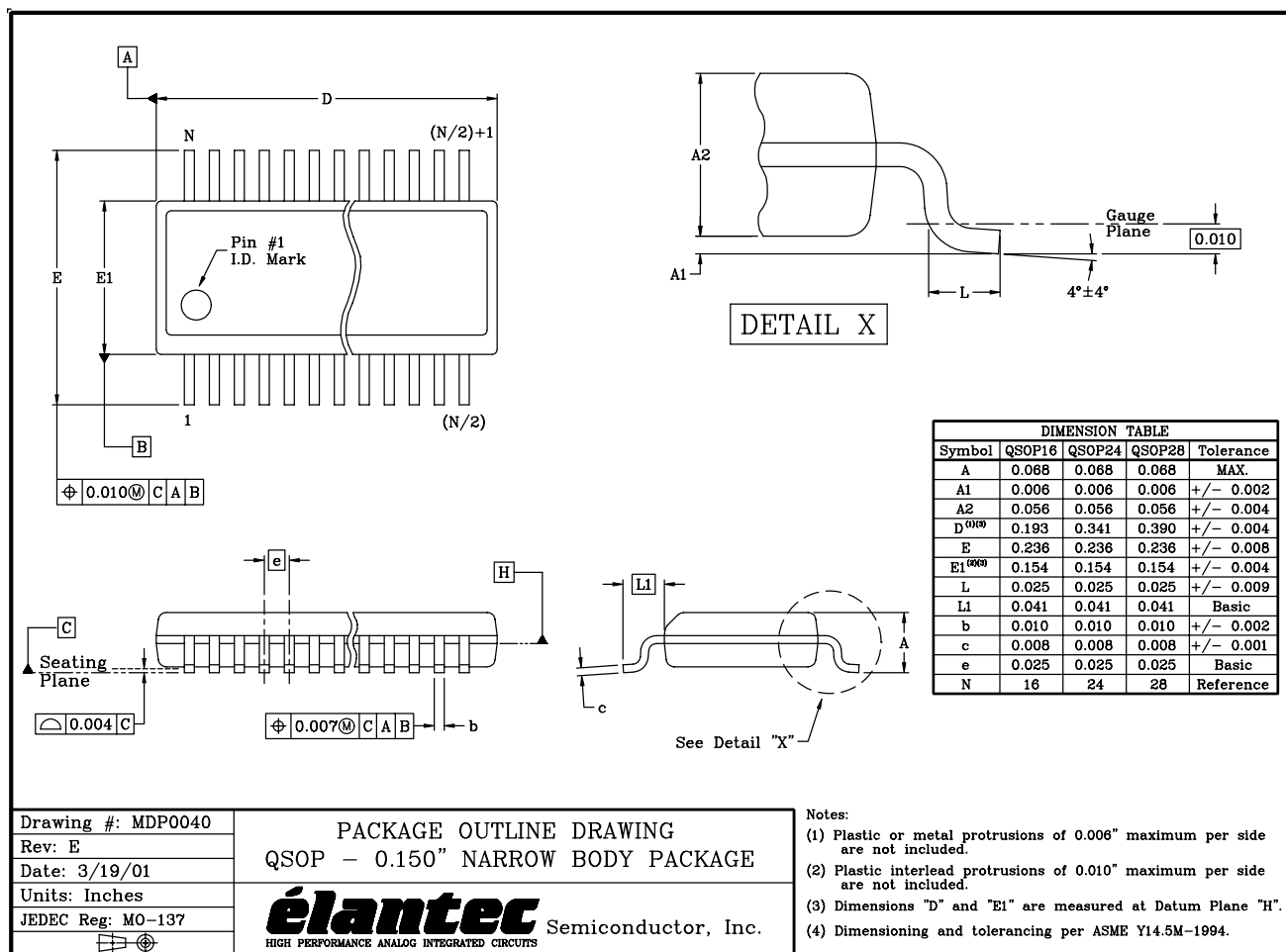

NOTE: The package drawing shown here may not be the latest version. To check the latest revision, please refer to the Intersil website at <http://www.intersil.com/design/packages/index.asp>

All Intersil U.S. products are manufactured, assembled and tested utilizing ISO9000 quality systems. Intersil Corporation's quality certifications can be viewed at [www.intersil.com/design/quality](http://www.intersil.com/design/quality)

Intersil products are sold by description only. Intersil Corporation reserves the right to make changes in circuit design, software and/or specifications at any time without notice. Accordingly, the reader is cautioned to verify that data sheets are current before placing orders. Information furnished by Intersil is believed to be accurate and reliable. However, no responsibility is assumed by Intersil or its subsidiaries for its use; nor for any infringements of patents or other rights of third parties which may result from its use. No license is granted by implication or otherwise under any patent or patent rights of Intersil or its subsidiaries.

For information regarding Intersil Corporation and its products, see [www.intersil.com](http://www.intersil.com)