

**40MHz, PRAM Four Channel Programmable Amplifiers**

The HA-2404 comprise a series of four-channel programmable amplifiers providing a level of versatility unsurpassed by any other monolithic operational amplifier. Versatility is achieved by employing four input amplifier channels, any one (or none) of which may be electronically selected and connected to a single output stage through DTL/TTL compatible address inputs. The device formed by the output and the selected pair of inputs is an op amp which delivers excellent slew rate, gain bandwidth and power bandwidth performance. Other advantageous features for these dielectrically isolated amplifiers include high voltage gain and input impedance coupled with low input offset voltage and offset current. External compensation is not required on this device at closed loop gains greater than 10.

Each channel of the HA-2404 can be controlled and operated with suitable feedback networks in any of the standard op amp configurations. This specialization makes these amplifiers excellent components for multiplexing signal selection and mathematical function designs. With 30V/μs slew rate, 40MHz gain bandwidth and 30MΩ input impedance these devices are ideal building blocks for signal generators, active filters and data acquisition designs. Programmability, coupled with 4mV typical offset voltage and 5nA offset current, makes these amplifiers outstanding components for signal conditioning circuits.

During Disable Mode  $V_{OUT}$  goes to  $V^-$ . For high output impedance during Disable, see HA2444.

For further design ideas, see Application Note AN514.

**Ordering Information**

PART NUMBER	TEMP. RANGE (°C)	PACKAGE	PKG. DWG. #
HA1-2404-4	-25 to 85	16 Ld CERDIP	F16.3

**TRUTH TABLE**

D1	D0	EN	SELECTED CHANNEL	D1
L	L	H	1	L
L	H	H	2	L
H	L	H	3	H
H	H	H	4	H
X	X	L	None, $V_{OUT}$ goes to $V^-$	X

**Features**

- Programmability
- High Rate Slew ..... 30V/μs
- Wide Gain Bandwidth..... 40MHz
- High Gain ..... 150kV/V
- Low Offset Current..... 5nA
- High Input Impedance ..... 30MΩ
- Single Capacitor Compensation
- DTL/TTL Compatible Inputs

**Applications**

- Thousands of Applications; Program
  - Signal Selection/Multiplexing
  - Operational Amplifier Gain
  - Oscillator Frequency
  - Filter Characteristics
  - Add-Subtract Functions
  - Integrator Characteristics
  - Comparator Levels

**Pinout**

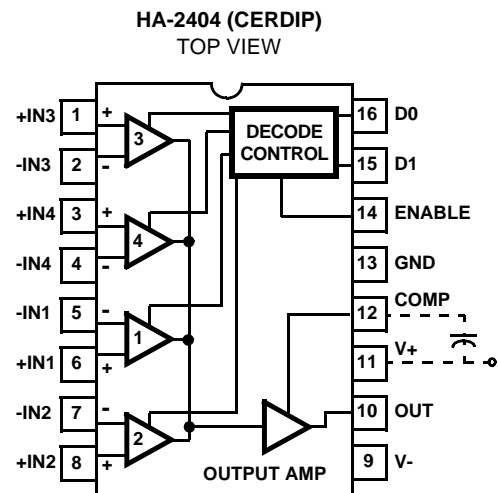

# HA-2404

## Absolute Maximum Ratings (T<sub>A</sub> = 25°C)

Voltage Between V+ and V- Terminals	45.0V
Differential Input Voltage	V <sub>SUPPLY</sub>
Digital Input Voltage	-0.76V to +10.0V
Output Current	Short Circuit Protected, I <sub>SC</sub> < ±33mA
Internal Power Dissipation (Note 1)	

## Thermal Information

Thermal Resistance (Typical, Note 2)	θ <sub>JA</sub> (°C/W)	θ <sub>JC</sub> (°C/W)
CERDIP Package	75	22
Maximum Junction Temperature (Ceramic Package)	175°C	
Maximum Junction Temperature (Plastic Package)	150°C	
Maximum Storage Temperature Range	-65°C to 150°C	
Maximum Lead Temperature (Soldering 10s)	300°C	

## Operating Conditions

Temperature Range	
HA-2404-4	-25°C to 85°C

**CAUTION:** Stresses above those listed in "Absolute Maximum Ratings" may cause permanent damage to the device. This is a stress only rating and operation of the device at these or any other conditions above those indicated in the operational sections of this specification is not implied.

### NOTES:

- Maximum power dissipation including output load, must be designed to maintain the junction temperature below 175°C for the ceramic package, and below 150°C for the plastic packages.
- θ<sub>JA</sub> is measured with the component mounted on a low effective thermal conductivity test board in free air. See Tech Brief TB379 for details.

**Electrical Specifications** Test Conditions: V<sub>SUPPLY</sub> = ±15V, Unless Otherwise Specified. Digital Inputs: V<sub>IL</sub> = +0.5V, V<sub>IH</sub> = +2.4. Limits apply to each of the four channels, when addressed

PARAMETER	TEST CONDITIONS	TEMP. (°C)	HA-2404			UNITS
			MIN	TYP	MAX	
<b>INPUT CHARACTERISTICS</b>						
Offset Voltage		25	-	4	9	mV
		Full	-	-	11	mV
Bias Current (Note 8)		25	-	50	200	nA
		Full	-	-	400	nA
Offset Current (Note 8)		25	-	5	50	nA
		Full	-	-	100	nA
Input Resistance (Note 8)		25	-	30	-	MΩ
Common Mode Range		Full	±9.0	-	-	V
<b>TRANSFER CHARACTERISTICS</b>						
Large Signal Voltage Gain	R <sub>L</sub> = 2kΩ	25	50	150	-	kV/V
	V <sub>OUT</sub> = 20V <sub>P-P</sub>	Full	25	-	-	kV/V
Common Mode Rejection Ratio	V <sub>CM</sub> = ±5V	Full	80	100	-	dB
Gain Bandwidth (Notes 3, 9)		25	20	40	-	MHz
Gain Bandwidth (Notes 4, 9)		25	4	8	-	MHz
Minimum Stable Gain	(C <sub>COMP</sub> = 0)		10	-	-	V/V
<b>OUTPUT CHARACTERISTICS</b>						
Output Voltage Swing	R <sub>L</sub> = 2kΩ	Full	±10.0	±12.0	-	V
Output Current		25	10	20	-	mA
Full Power Bandwidth (Notes 3, 10)	V <sub>OUT</sub> = 20V <sub>P-P</sub>	25	640	950	-	kHz
Full Power Bandwidth (Notes 4, 10)	V <sub>OUT</sub> = 20V <sub>P-P</sub>	25	200	250	-	kHz
<b>TRANSIENT RESPONSE (Note 11)</b>						
Rise Time (Note 4)	V <sub>OUT</sub> = 200mV <sub>PEAK</sub>	25	-	20	45	ns
Overshoot (Note 4)	V <sub>OUT</sub> = 200mV <sub>PEAK</sub>	25	-	25	40	%
Slew Rate (Note 3)	V <sub>OUT</sub> = 10V <sub>P-P</sub>	25	20	30	-	V/μs
Slew Rate (Notes 4, 9)	V <sub>OUT</sub> = 10V <sub>P-P</sub>	25	6	8	-	V/μs

## HA-2404

**Electrical Specifications** Test Conditions:  $V_{SUPPLY} = \pm 15V$ , Unless Otherwise Specified. Digital Inputs:  $V_{IL} = +0.5V$ ,  $V_{IH} = +2.4$ . Limits apply to each of the four channels, when addressed **(Continued)**

PARAMETER	TEST CONDITIONS	TEMP. (°C)	HA-2404			UNITS
			MIN	TYP	MAX	
Settling Time (Notes 4, 5, 9)	$V_{OUT} = 10V_{P-P}$	25	-	1.5	2.5	$\mu s$
<b>CHANNEL SELECT CHARACTERISTICS</b>						
Digital Input Current	$V_{IN} = 0V$	Full	-	1	1.5	mA
Digital Input Current	$V_{IN} = +5.0V$	Full	-	5	-	nA
Output Delay (Notes 6, 9)		25	-	100	250	ns
Crosstalk (Note 7)		25	-80	-110	-	dB
<b>POWER SUPPLY CHARACTERISTICS</b>						
Supply Current		25	-	4.8	6.0	mA
Power Supply Rejection Ratio	$V_S = \pm 10V$ to $\pm 20V$	Full	74	90	-	dB

**NOTES:**

3.  $A_V = +10$ ,  $C_{COMP} = 0$ ,  $R_L = 2k\Omega$ ,  $C_L = 50pF$ .
4.  $A_V = +1$ ,  $C_{COMP} = 15pF$ ,  $R_L = 2k\Omega$ ,  $C_L = 50pF$ .
5. To 0.1% of final value.
6. To 10% of final value; output then slews at normal rate to final value.
7. Unselected input to output;  $V_{IN} = \pm 10V_{DC}$ .
8. Unselected channels have approximately the same input parameters.
9. Guaranteed by design.
10. Full Power Bandwidth based on slew rate measurement using:  $FPBW = \frac{SR}{2\pi V_{PEAK}}$ ;  $V_{PEAK} = 5V$ .
11. See Figure 13 for test circuit.

Schematic Diagram

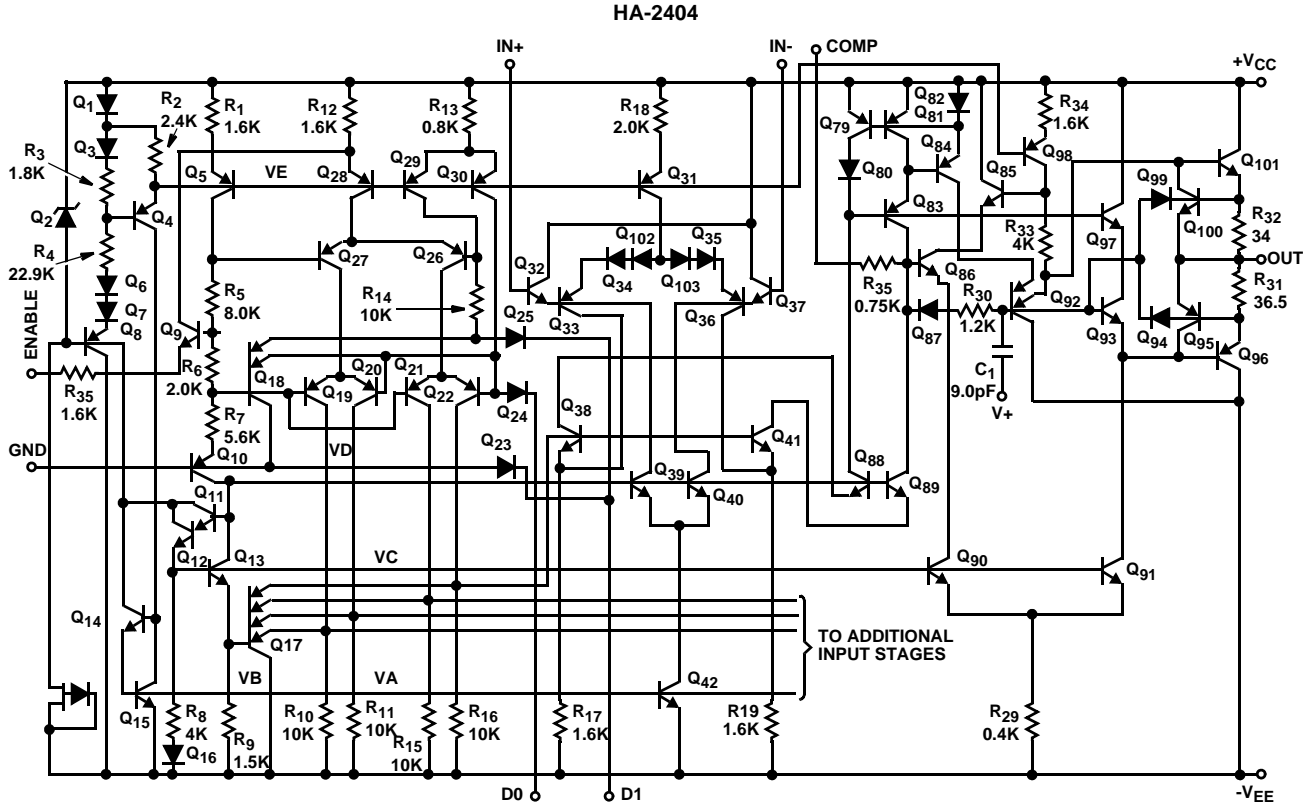

Diagram Includes: One Input Stage, Decode Control, Bias Network, and Output Stage

Typical Applications

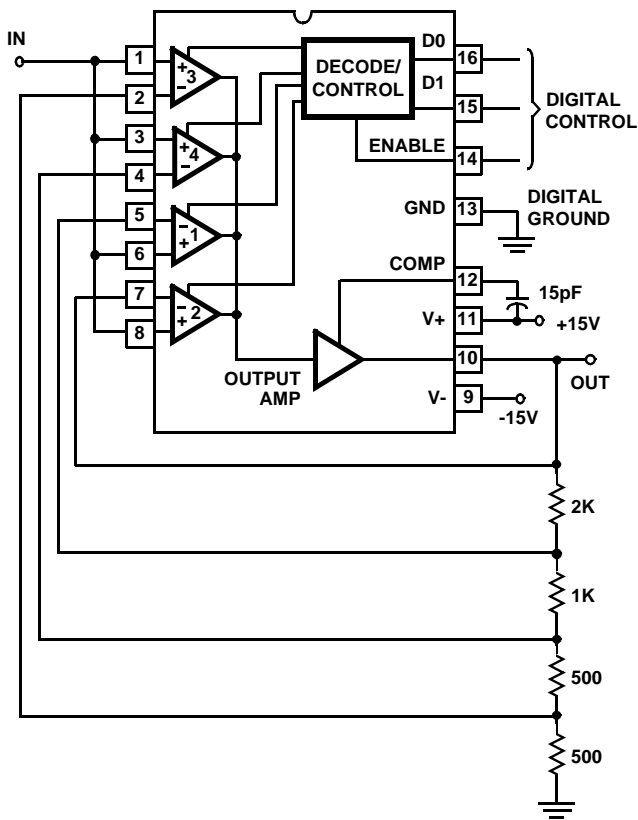
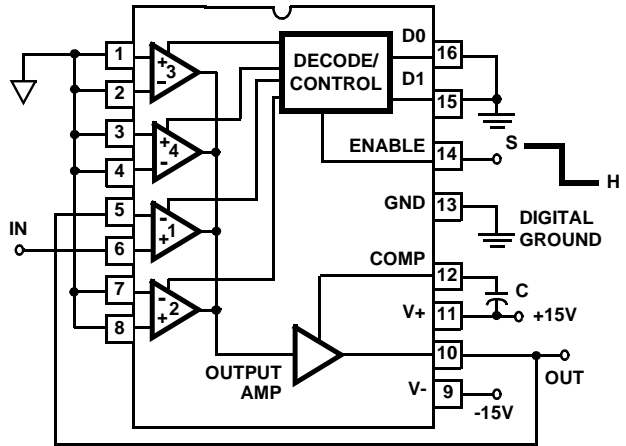

FIGURE 1. HA-2404 AMPLIFIER, NONINVERTING PROGRAMMABLE GAIN



$$\text{Sample Charging Rate} = \frac{I_1}{C} \text{V/s}$$

$$\text{Hold Drift Rate} = \frac{I_2}{C} \text{V/s}$$

$$\text{Switch Pedestal Error} = \frac{Q}{C} \text{V}$$

- $I_1 \approx 150 \times 10^{-6} \text{A}$
- $I_2 \approx 200 \times 10^{-9} \text{A}$  at  $25^\circ\text{C}$
- $\approx 600 \times 10^{-9} \text{A}$  at  $-55^\circ\text{C}$
- $\approx 100 \times 10^{-9} \text{A}$  at  $125^\circ\text{C}$
- $Q \approx 2 \times 10^{-12} \text{C}$

FIGURE 2. HA-2404 SAMPLE AND HOLD

For more examples, see Intersil Application Note AN514.

Typical Performance Curves

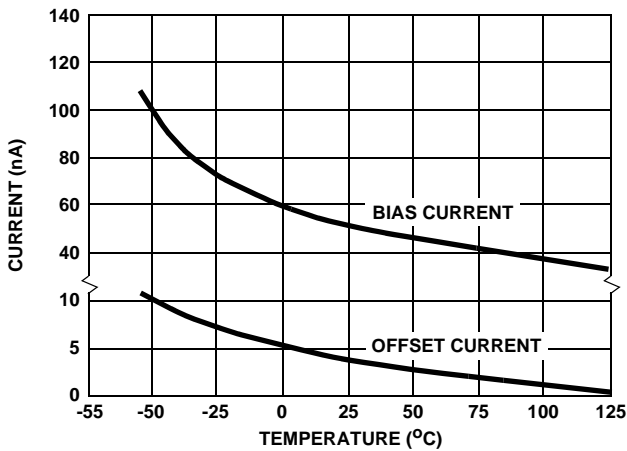

FIGURE 3. INPUT BIAS CURRENT AND OFFSET CURRENT vs TEMPERATURE

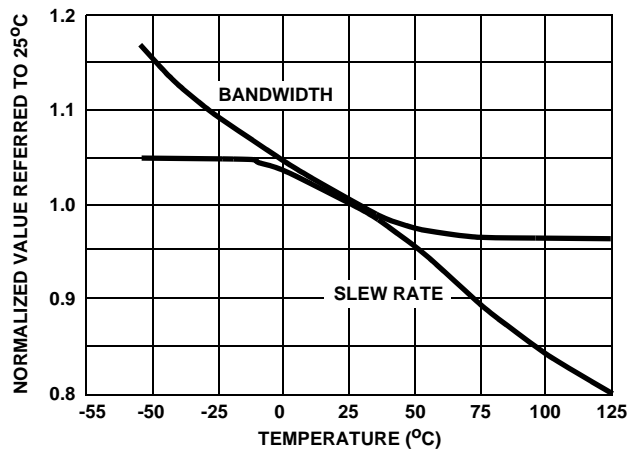

FIGURE 4. NORMALIZED AC PARAMETERS vs TEMPERATURE

Typical Performance Curves (Continued)

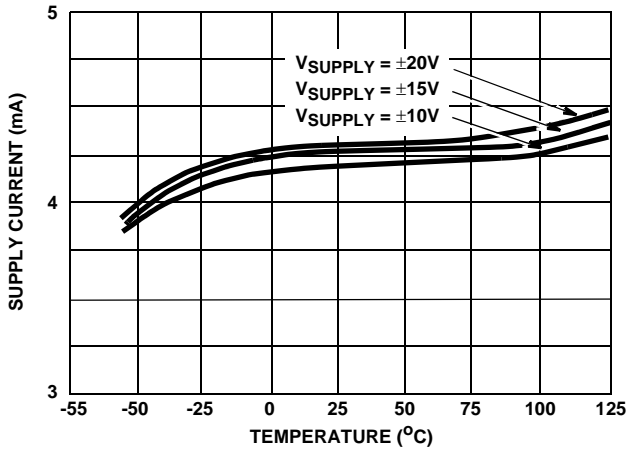

FIGURE 5. POWER SUPPLY CURRENT vs TEMPERATURE

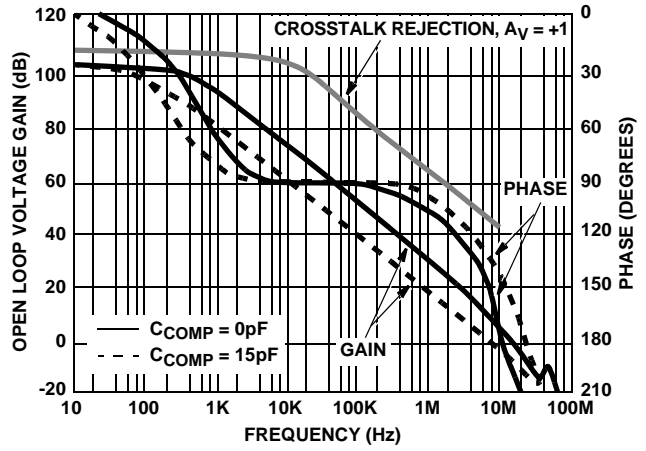

FIGURE 6. OPEN LOOP FREQUENCY AND PHASE RESPONSE

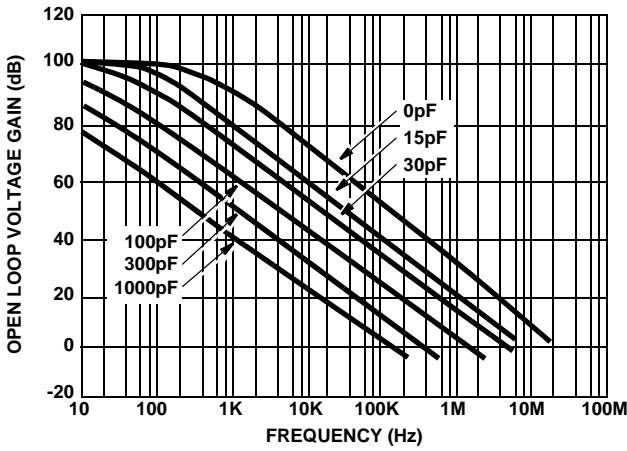

FIGURE 7. FREQUENCY RESPONSE vs C<sub>COMP</sub>

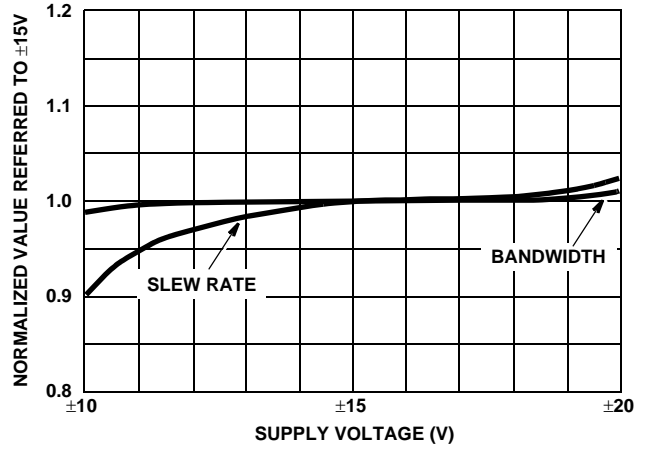

FIGURE 8. NORMALIZED AC PARAMETERS vs SUPPLY VOLTAGE

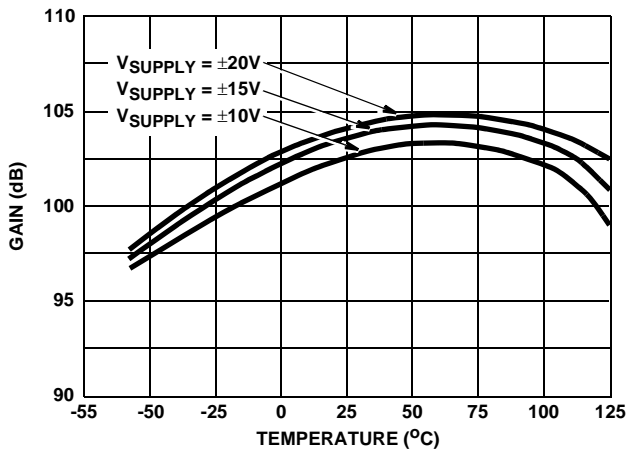

FIGURE 9. OPEN LOOP VOLTAGE GAIN vs TEMPERATURE

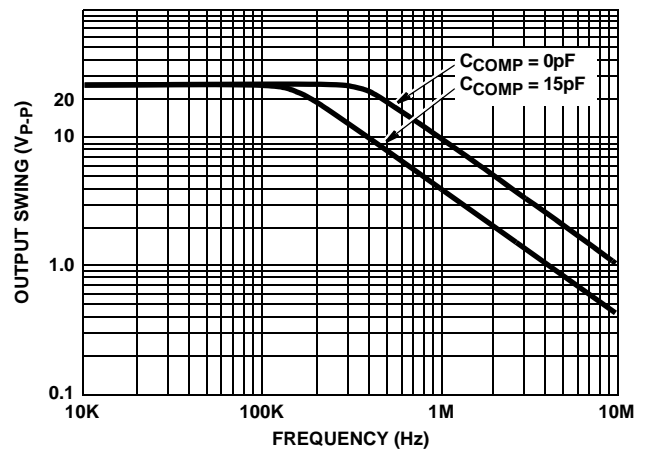

FIGURE 10. OUTPUT VOLTAGE SWING vs FREQUENCY

Typical Performance Curves (Continued)

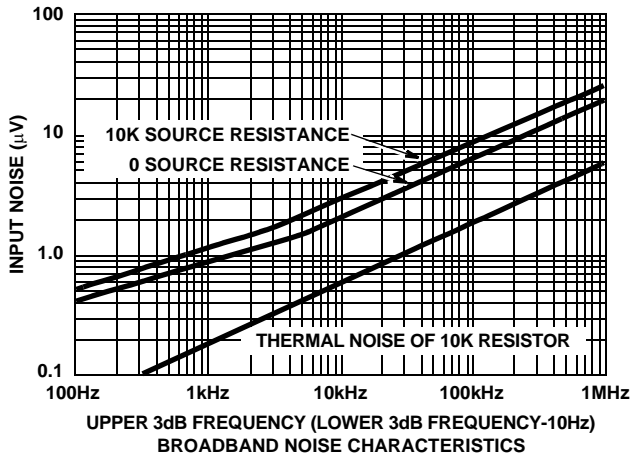

FIGURE 11. EQUIVALENT INPUT NOISE vs BANDWIDTH

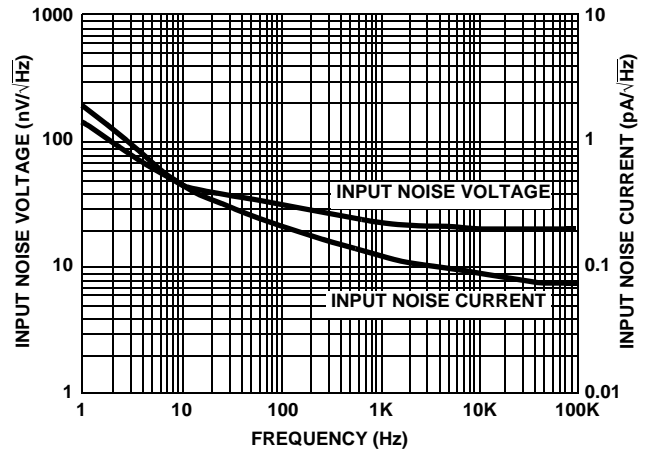

FIGURE 12. INPUT NOISE vs FREQUENCY

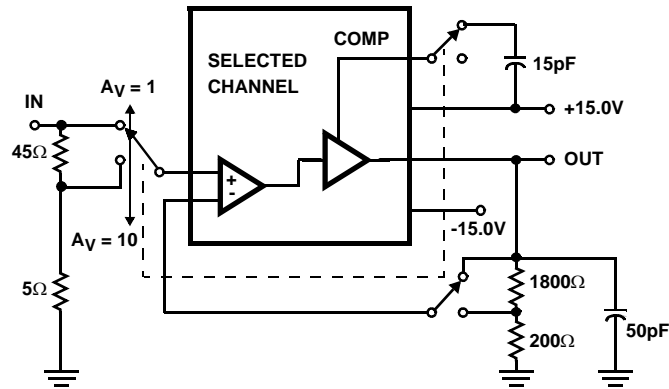
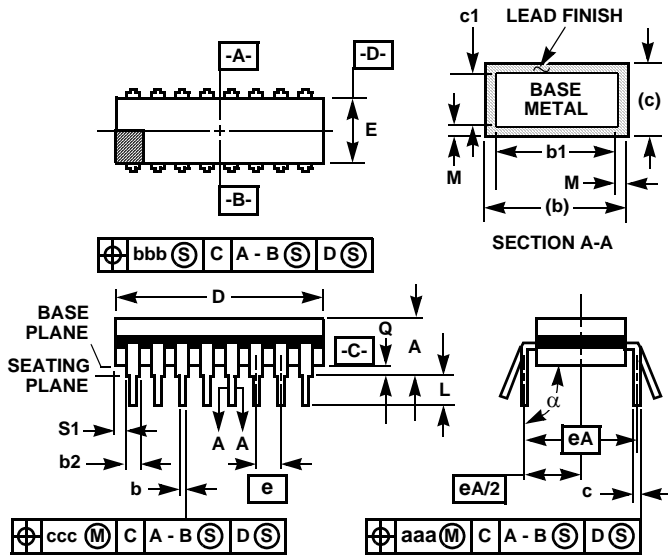

FIGURE 13. SLEW RATE AND TRANSIENT RESPONSE

**Ceramic Dual-In-Line Frit Seal Packages (CERDIP)**



**NOTES:**

1. Index area: A notch or a pin one identification mark shall be located adjacent to pin one and shall be located within the shaded area shown. The manufacturer's identification shall not be used as a pin one identification mark.
2. The maximum limits of lead dimensions b and c or M shall be measured at the centroid of the finished lead surfaces, when solder dip or tin plate lead finish is applied.
3. Dimensions b1 and c1 apply to lead base metal only. Dimension M applies to lead plating and finish thickness.
4. Corner leads (1, N, N/2, and N/2+1) may be configured with a partial lead paddle. For this configuration dimension b3 replaces dimension b2.
5. This dimension allows for off-center lid, meniscus, and glass overrun.
6. Dimension Q shall be measured from the seating plane to the base plane.
7. Measure dimension S1 at all four corners.
8. N is the maximum number of terminal positions.
9. Dimensioning and tolerancing per ANSI Y14.5M - 1982.
10. Controlling dimension: INCH.

**F16.3 MIL-STD-1835 GDIP1-T16 (D-2, CONFIGURATION A)  
16 LEAD CERAMIC DUAL-IN-LINE FRIT SEAL PACKAGE**

SYMBOL	INCHES		MILLIMETERS		NOTES
	MIN	MAX	MIN	MAX	
A	-	0.200	-	5.08	-
b	0.014	0.026	0.36	0.66	2
b1	0.014	0.023	0.36	0.58	3
b2	0.045	0.065	1.14	1.65	-
b3	0.023	0.045	0.58	1.14	4
c	0.008	0.018	0.20	0.46	2
c1	0.008	0.015	0.20	0.38	3
D	-	0.840	-	21.34	5
E	0.220	0.310	5.59	7.87	5
e	0.100 BSC		2.54 BSC		-
eA	0.300 BSC		7.62 BSC		-
eA/2	0.150 BSC		3.81 BSC		-
L	0.125	0.200	3.18	5.08	-
Q	0.015	0.060	0.38	1.52	6
S1	0.005	-	0.13	-	7
$\alpha$	90°	105°	90°	105°	-
aaa	-	0.015	-	0.38	-
bbb	-	0.030	-	0.76	-
ccc	-	0.010	-	0.25	-
M	-	0.0015	-	0.038	2, 3
N	16		16		8

Rev. 0 4/94

All Intersil U.S. products are manufactured, assembled and tested utilizing ISO9000 quality systems. Intersil Corporation's quality certifications can be viewed at [www.intersil.com/design/quality](http://www.intersil.com/design/quality)

*Intersil products are sold by description only. Intersil Corporation reserves the right to make changes in circuit design, software and/or specifications at any time without notice. Accordingly, the reader is cautioned to verify that data sheets are current before placing orders. Information furnished by Intersil is believed to be accurate and reliable. However, no responsibility is assumed by Intersil or its subsidiaries for its use; nor for any infringements of patents or other rights of third parties which may result from its use. No license is granted by implication or otherwise under any patent or patent rights of Intersil or its subsidiaries.*

For information regarding Intersil Corporation and its products, see [www.intersil.com](http://www.intersil.com)