

30MHz, Voltage Output, Two Quadrant Analog Multiplier

The HA-2546 is a monolithic, high speed, two quadrant, analog multiplier constructed in the Intersil Dielectrically Isolated High Frequency Process. The HA-2546 has a voltage output with a 30MHz signal bandwidth, 300V/μs slew rate and a 17MHz control bandwidth. High bandwidth and slew rate make this part an ideal component for use in video systems. The suitability for precision video applications is demonstrated further by the 0.1dB gain flatness to 5MHz, 1.6% multiplication error, -52dB feedthrough and differential inputs with 1.2μA bias currents. The HA-2546 also has low differential gain (0.1%) and phase (0.1 degree) errors.

The HA-2546 is well suited for AGC circuits as well as mixer applications for sonar, radar, and medical imaging equipment. The voltage output simplifies many designs by eliminating the current to voltage conversion stage required for current output multipliers. For MIL-STD-883 compliant product, consult the HA-2546/883 datasheet.

Pinout

**HA-2546 (SOIC)
TOP VIEW**

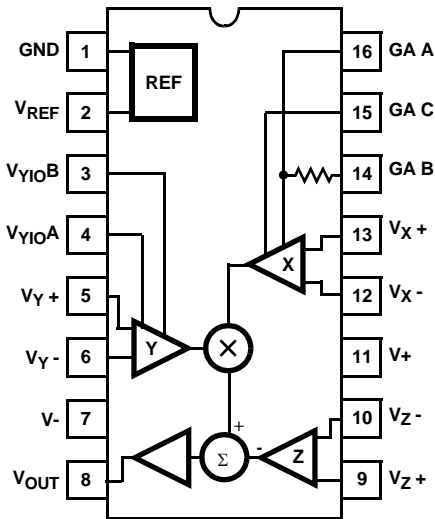

Features

- High Speed Voltage Output 300V/μs
- Low Multiplication error 1.6%
- Input Bias Currents 1.2μA
- Signal Input Feedthrough -52dB
- Wide Signal Bandwidth 30MHz
- Wide Control Bandwidth 17MHz
- Gain Flatness to 5MHz 0.10dB

Applications

- Military Avionics
- Missile Guidance Systems
- Medical Imaging Displays
- Video Mixers
- Sonar AGC Processors
- Radar Signal Conditioning
- Voltage Controlled Amplifier
- Vector Generator

Ordering Information

PART NUMBER	TEMP. RANGE (°C)	PACKAGE	PKG. DWG. #
HA9P2546-5	0 to 65	16 Ld SOIC	M16.3

Simplified Schematic

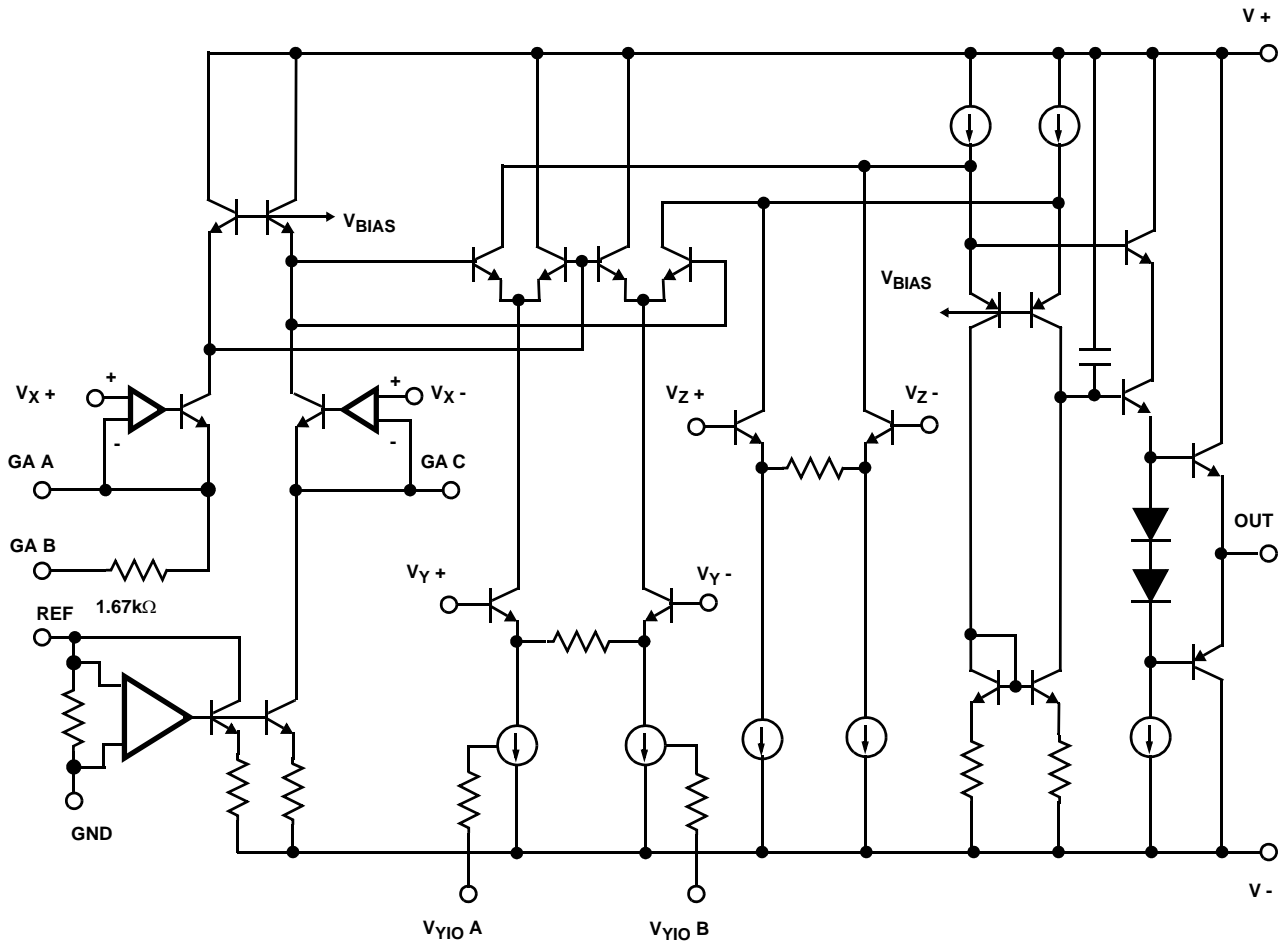

Absolute Maximum Ratings

Voltage Between V+ and V- 35V
 Differential Input Voltage 6V
 Output Current ±60mA

Operating Conditions

Temperature Range
 HA9P2546-5 0°C to 65°C

Thermal Information

Thermal Resistance (Typical, Note 1) θ_{JA} (°C/W) θ_{JC} (°C/W)
 SOIC Package 96 N/A
 Maximum Junction Temperature (Plastic Package) 150°C
 Maximum Storage Temperature Range -65°C to 150°C
 Maximum Lead Temperature (Soldering 10s) 300°C
 (Lead Tips Only)

CAUTION: Stresses above those listed in "Absolute Maximum Ratings" may cause permanent damage to the device. This is a stress only rating and operation of the device at these or any other conditions above those indicated in the operational sections of this specification is not implied.

NOTE:

- θ_{JA} is measured with the component mounted on an evaluation PC board in free air.

Electrical Specifications $V_{SUPPLY} = \pm 15V$, $R_L = 1k\Omega$, $C_L = 50pF$, Unless Otherwise Specified

PARAMETER	TEST CONDITIONS	TEMP (°C)	MIN	TYP	MAX	UNITS
MULTIPLIER PERFORMANCE						
Multiplication Error (Note 2)		25	-	1.6	3	%
		Full	-	3.0	7	%
Multiplication Error Drift		Full	-	0.003	-	%/°C
Differential Gain (Notes 3, 9)		25	-	0.1	0.2	%
Differential Phase (Notes 3, 9)		25	-	0.1	0.3	Degrees
Gain Flatness (Note 9)	DC to 5MHz, $V_X = 2V$	25	-	0.1	0.2	dB
	5 MHz to 8MHz, $V_X = 2V$	25	-	0.18	0.3	dB
Scale Factor Error		Full	-	0.7	5.0	%
1% Amplitude Bandwidth Error		25	-	6	-	MHz
1% Vector Bandwidth Error		25	-	260	-	kHz
THD + N (Note 4)		25	-	0.03	-	%
Voltage Noise	$f_O = 10Hz$, $V_X = V_Y = 0V$	25	-	400	-	nV/ \sqrt{Hz}
	$f_O = 100Hz$, $V_X = V_Y = 0V$	25	-	150	-	nV/ \sqrt{Hz}
	$f_O = 1kHz$, $V_X = V_Y = 0V$	25	-	75	-	nV/ \sqrt{Hz}
Common Mode Range		25	-	±9	-	V
SIGNAL INPUT, V_Y						
Input Offset Voltage		25	-	3	10	mV
		Full	-	8	20	mV
Average Offset Voltage Drift		Full	-	45	-	$\mu V/^\circ C$
Input Bias Current		25	-	7	15	μA
		Full	-	10	15	μA

HA-2546

Electrical Specifications $V_{\text{SUPPLY}} = \pm 15\text{V}$, $R_L = 1\text{k}\Omega$, $C_L = 50\text{pF}$, Unless Otherwise Specified (Continued)

PARAMETER	TEST CONDITIONS	TEMP (°C)	MIN	TYP	MAX	UNITS
Input Offset Current		25	-	0.7	2	μA
		Full	-	1.0	3	μA
Input Capacitance		25	-	2.5	-	pF
Differential Input Resistance		25	-	720	-	k Ω
Small Signal Bandwidth (-3dB)	$V_X = 2\text{V}$	25	-	30	-	MHz
Full Power Bandwidth (Note 5)	$V_X = 2\text{V}$	25	-	9.5	-	MHz
Feedthrough	Note 11	25	-	-52	-	dB
CMRR	Note 6	Full	60	78	-	dB
V_Y TRANSIENT RESPONSE (Note 10)						
Slew Rate	$V_{\text{OUT}} = \pm 5\text{V}$, $V_X = 2\text{V}$	25	-	300	-	V/ μs
Rise Time	Note 7	25	-	11	-	ns
Overshoot	Note 7	25	-	17	-	%
Propagation Delay		25	-	25	-	ns
Settling Time (To 0.1%)	$V_{\text{OUT}} = \pm 5\text{V}$, $V_X = 2\text{V}$	25	-	200	-	ns
CONTROL INPUT, V_X						
Input Offset Voltage		25	-	0.3	2	mV
		Full	-	3	20	mV
Average Offset Voltage Drift		Full	-	10	-	$\mu\text{V}/^\circ\text{C}$
Input Bias Current		25	-	1.2	2	μA
		Full	-	1.8	5	μA
Input Offset Current		25	-	0.3	2	μA
		Full	-	0.4	3	μA
Input Capacitance		25	-	2.5	-	pF
Differential Input Resistance		25	-	360	-	k Ω
Small Signal Bandwidth (-3dB)	$V_Y = 5\text{V}$, $V_X = -1\text{V}$	25	-	17	-	MHz
Feedthrough	Note 12	25	-	-40	-	dB
Common Mode Rejection Ratio	Note 13	25	-	80	-	dB

Electrical Specifications $V_{SUPPLY} = \pm 15V$, $R_L = 1kW$, $C_L = 50pF$, Unless Otherwise Specified **(Continued)**

PARAMETER	TEST CONDITIONS	TEMP (°C)	MIN	TYP	MAX	UNITS
V_X TRANSIENT RESPONSE (Note 10)						
Slew Rate	Note 13	25	-	95	-	V/μs
Rise Time	Note 14	25	-	20	-	ns
Overshoot	Note 14	25	-	17	-	%
Propagation Delay		25	-	50	-	ns
Settling Time (To 0.1%)	Note 13	25	-	200	-	ns
V_Z CHARACTERISTICS						
Input Offset Voltage	$V_X = V_Y = 0V$	25	-	4	15	mV
		Full	-	8	20	mV
Open Loop Gain		25	-	70	-	dB
Differential Input Resistance		25	-	900	-	kΩ
OUTPUT CHARACTERISTICS						
Output Voltage Swing	$V_X = 2.5V$, $V_Y = \pm 5V$	Full	-	±6.25	-	V
Output Current		Full	±20	±45	-	mA
Output Resistance		25	-	1	-	Ω
POWER SUPPLY						
PSRR	Note 8	Full	58	63	-	dB
Supply Current		Full	-	23	29	mA

NOTES:

2. Error is percent of full scale, 1% = 50mV.
3. $f_O = 3.58MHz/4.43MHz$, $V_Y = 300mV_{P-P}$, 0 to 1V_{DC} offset, $V_X = 2V$.
4. $f_O = 10kHz$, $V_Y = 1V_{RMS}$, $V_X = 2V$.
5. Full Power Bandwidth calculated by equation: $FPBW = \frac{Slew\ Rate}{2\pi V_{PEAK}}$, $V_{PEAK} = 5V$.
6. $V_Y = 0$ to $\pm 5V$, $V_X = 2V$.
7. $V_{OUT} = 0$ to $\pm 100mV$, $V_X = 2V$.
8. $V_S = \pm 12V$ to $\pm 15V$, $V_Y = 5V$, $V_X = 2V$.
9. Guaranteed by characterization and not 100% tested.
10. See Test Circuit.
11. $f_O = 5MHz$, $V_X = 0$, $V_Y = 200mV_{RMS}$.
12. $f_O = 100kHz$, $V_Y = 0$, $V_{X+} = 200mV_{RMS}$, $V_{X-} = -0.5V$.
13. $V_X = 0$ to 2V, $V_Y = 5V$.
14. $V_X = 0$ to 200mV, $V_Y = 5V$.

Test Circuits and Waveforms

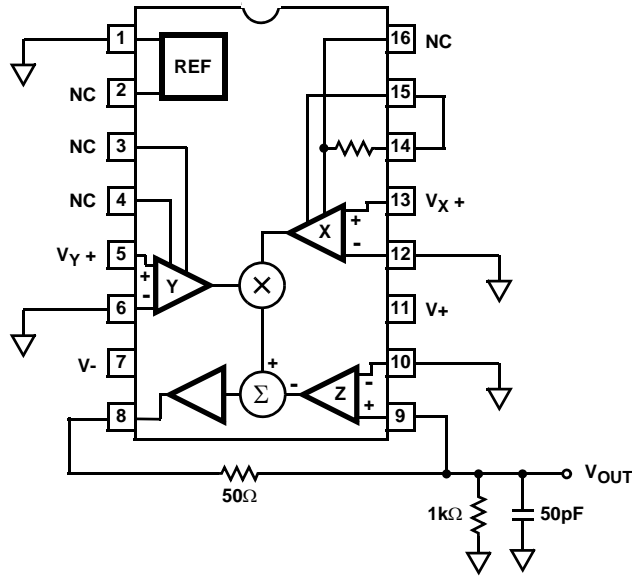
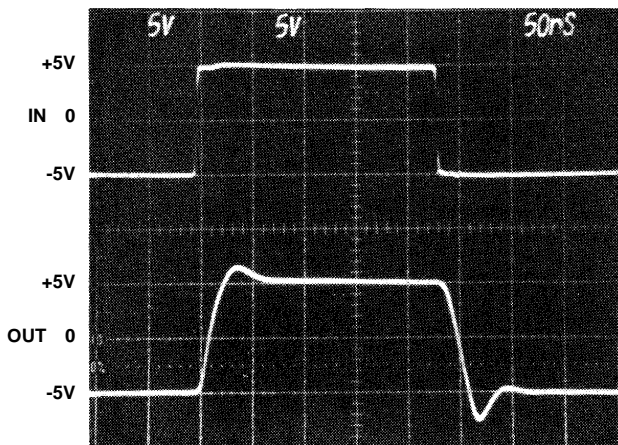
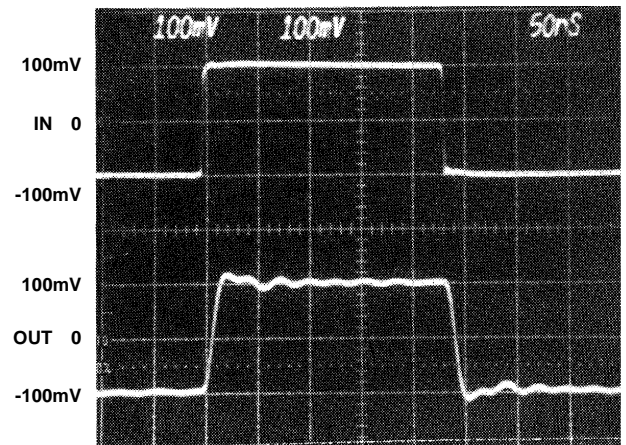

FIGURE 1. LARGE AND SMALL SIGNAL RESPONSE TEST CIRCUIT



VERTICAL SCALE: 5V/DIV HORIZONTAL SCALE: 50ns/DIV
V_Y LARGE SIGNAL RESPONSE



VERTICAL SCALE: 100mV/DIV HORIZONTAL SCALE: 50ns/DIV
V_Y SMALL SIGNAL RESPONSE

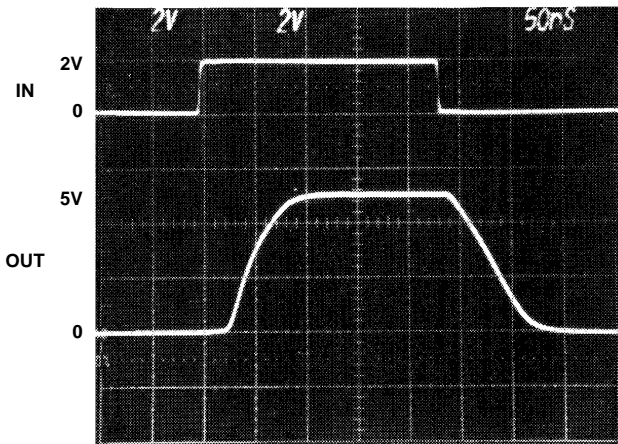

VERTICAL SCALE: 2V/DIV HORIZONTAL SCALE: 50ns/DIV
V_X LARGE SIGNAL RESPONSE

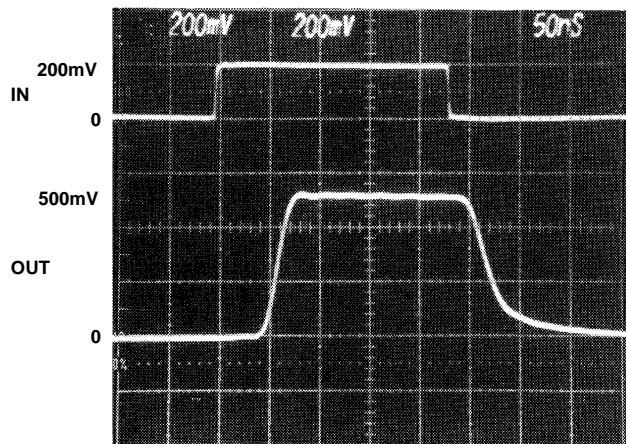

VERTICAL SCALE: 200mV/DIV HORIZONTAL SCALE: 50ns/DIV
V_X SMALL SIGNAL RESPONSE

Application Information

Theory Of Operation

The HA-2546 is a two quadrant multiplier with the following three differential inputs; the signal channel, V_{Y+} and V_{Y-} , the control channel, V_{X+} and V_{X-} , and the summed channel, V_{Z+} and V_{Z-} , to complete the feedback of the output amplifier. The differential voltages of channel X and Y are converted to differential currents. These currents are then multiplied in a circuit similar to a Gilbert Cell multiplier, producing a differential current product. The differential voltage of the Z channel is converted into a differential current which then sums with the products currents. The differential “product/sum” currents are converted to a single-ended current and then converted to a voltage output by a transimpedance amplifier.

The open loop transfer equation for the HA-2546 is:

$$V_{OUT} = A \left[\frac{(V_{X+} - V_{X-})(V_{Y+} - V_{Y-})}{SF} - (V_{Z+} - V_{Z-}) \right]$$

where; A = Output Amplifier Open Loop Gain
 SF = Scale Factor
 V_X, V_Y, V_Z = Differential Inputs

The scale factor is used to maintain the output of the multiplier within the normal operating range of $\pm 5V$. The scale factor can be defined by the user by way of an optional external resistor, R_{EXT} , and the Gain Adjust pins, Gain Adjust A (GA A), Gain Adjust B (GA B), and Gain Adjust C (GA C). The scale factor is determined as follows:

- SF = 2, when GA B is shorted to GA C
- SF $\cong 1.2 R_{EXT}$, when R_{EXT} is connected between GA A and GA C (R_{EXT} is in $k\Omega$)
- SF $\cong 1.2 (R_{EXT} + 1.667k\Omega)$, when R_{EXT} is connected to GA B and GA C (R_{EXT} is in $k\Omega$)

The scale factor can be adjusted from 2 to 5. It should be noted that any adjustments to the scale factor will affect the AC performance of the control channel, V_X . The normal input operating range of V_X is equal to the scale factor voltage.

The typical multiplier configuration is shown in Figure 2. The ideal transfer function for this configuration is:

$$V_{OUT} = \begin{cases} \frac{(V_{X+} - V_{X-})(V_{Y+} - V_{Y-})}{2} + V_{Z-}, & \text{when } V_X \geq 0V \\ 0, & \text{when } V_X < 0V \end{cases}$$

The V_{X-} pin is usually connected to ground so that when V_{X+} is negative there is no signal at the output, i.e. two quadrant operation. If the V_X input is a negative going signal the V_{X+} pin maybe grounded and the V_{X-} pin used as the control input.

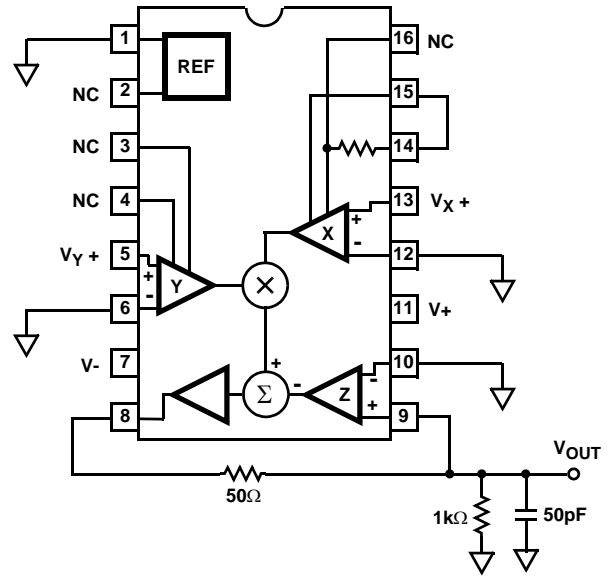

FIGURE 2.

The V_{Y-} terminal is usually grounded allowing the V_{Y+} to swing $\pm 5V$. The V_{Z+} terminal is usually connected directly to V_{OUT} to complete the feedback loop of the output amplifier while V_{Z-} is grounded. The scale factor is normally set to 2 by connecting GA B to GA C. Therefore the transfer equation simplifies to $V_{OUT} = (V_X V_Y) / 2$.

Offset Adjustment

The signal channel offset voltage may be nulled by using a 20k Ω potentiometer between V_{YIO} Adjust pins A and B and connecting the wiper to V_{-} . Reducing the signal channel offset will reduce V_X AC feedthrough. Output offset voltage can also be nulled by connecting V_{Z-} to the wiper of a 20k Ω potentiometer which is tied between V_{+} and V_{-} .

Capacitive Drive Capability

When driving capacitive loads $>20pF$, a 50 Ω resistor is recommended between V_{OUT} and V_{Z+} , using V_{Z+} as the output (see Figure 2). This will prevent the multiplier from going unstable.

Power Supply Decoupling

Power supply decoupling is essential for high frequency circuits. A 0.01 μF high quality ceramic capacitor at each supply pin in parallel with a 1 μF tantalum capacitor will provide excellent decoupling. Chip capacitors produce the best results due to the close spacing with which they may be placed to the supply pins minimizing lead inductance.

Adjusting Scale Factor

Adjusting the scale factor will tailor the control signal, V_X , input voltage range to match your needs. Referring to the simplified schematic on the front page and looking for the V_X input stage, you will notice the unusual design. The internal reference sets up a 1.2mA current sink for the V_X differential pair. The control signal applied to this input will be forced across the scale factor setting resistor and set the current flowing in the V_{X+} side of the differential pair. When the

current through this resistor reaches 1.2mA, all the current available is flowing in the one side and full scale has been reached. Normally the 1.67kΩ internal resistor sets the scale factor to 2V when the Gain Adjust pins B and C are connected together, but you may set this resistor to any convenient value using pins 16 (GA A) and 15 (GA C) (See Figure 3).

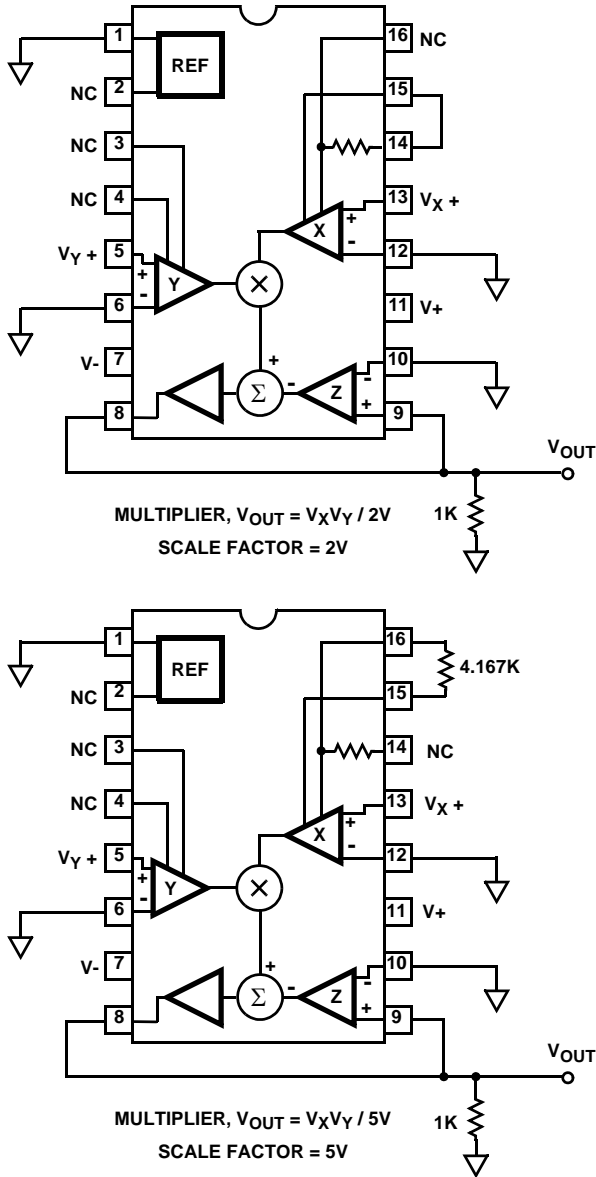

FIGURE 3. SETTING THE SCALE FACTOR

Typical Applications

Automatic Gain Control

In Figure 4 the HA-2546 is configured in a true Automatic Gain Control or AGC application. The HA-5127, low noise op amp, provides the gain control level to the X input. This level will set the peak output voltage of the multiplier to match the reference level. The feedback network around the HA-5127

provides stability and a response time adjustment for the gain control circuit.

This multiplier has the advantage over other AGC circuits, in that the signal bandwidth is not affected by the control signal gain adjustment.

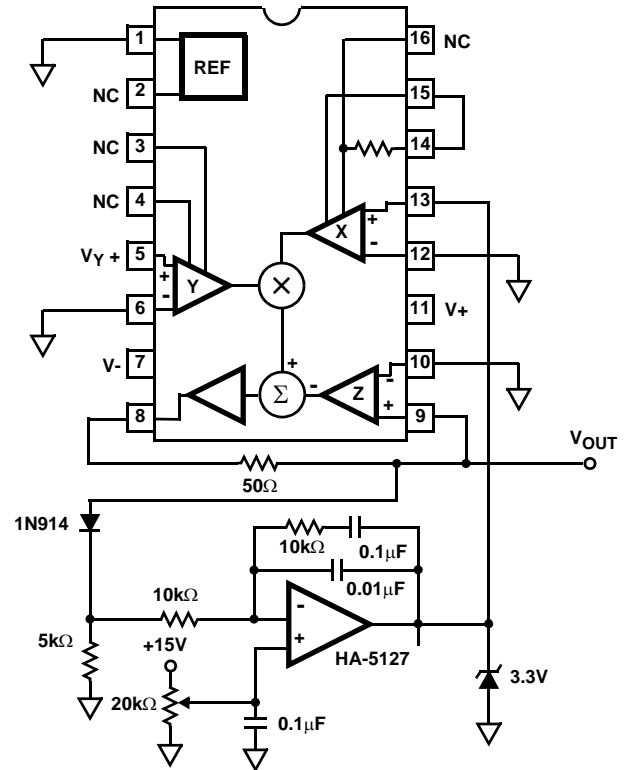

FIGURE 4. AUTOMATIC GAIN CONTROL

Voltage Controlled Amplifier

A wide range of gain adjustment is available with the Voltage Controlled Amplifier configuration shown in Figure 5. Here the gain of the HFA0002 is swept from 20V/V at a control voltage of 0.902V to a gain of almost 1000V/V with a control voltage of 0.03V.

Video Fader

The Video Fader circuit provides a unique function. Here Ch B is applied to the minus Z input in addition to the minus Y input. In this way, the function in Figure 6 is generated. V_{MIX} will control the percentage of Ch A and Ch B that are mixed together to produce a resulting video image or other signal.

Many other applications are possible including division, squaring, square-root, percentage calculations, etc. Please refer to the HA-2556 four quadrant multiplier data sheet for additional applications.

Typical Performance Curves $V_S = \pm 15V$, $T_A = 25^\circ C$, See Test Circuit For Multiplier Configuration

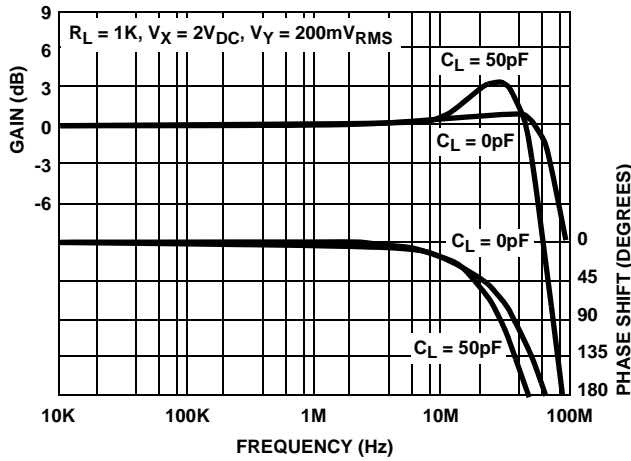

FIGURE 7. V_Y GAIN AND PHASE vs FREQUENCY

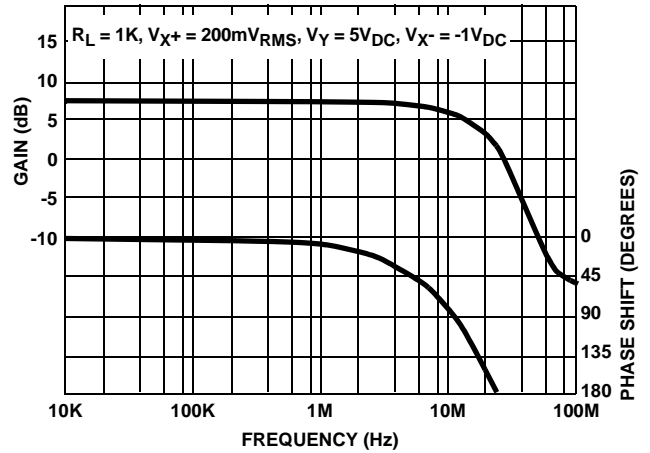

FIGURE 8. V_X GAIN AND PHASE vs FREQUENCY

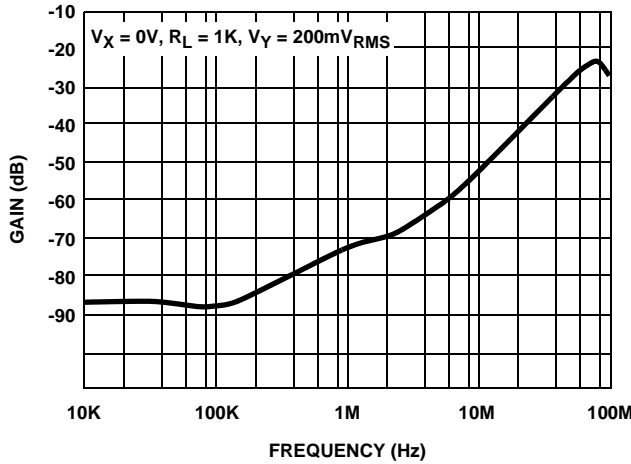

FIGURE 9. V_Y FEEDTHROUGH vs FREQUENCY

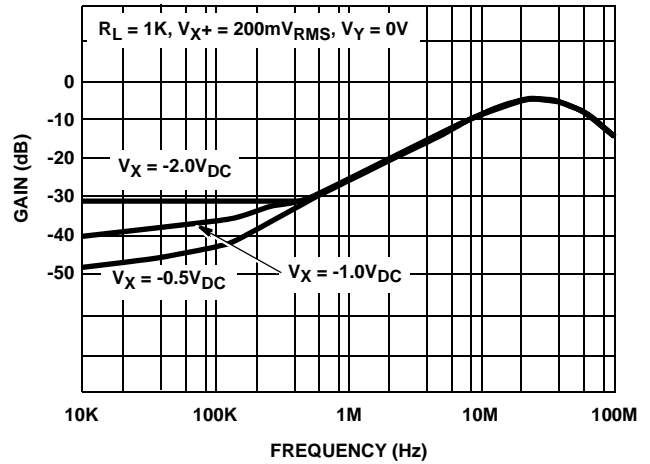

FIGURE 10. V_X FEEDTHROUGH vs FREQUENCY

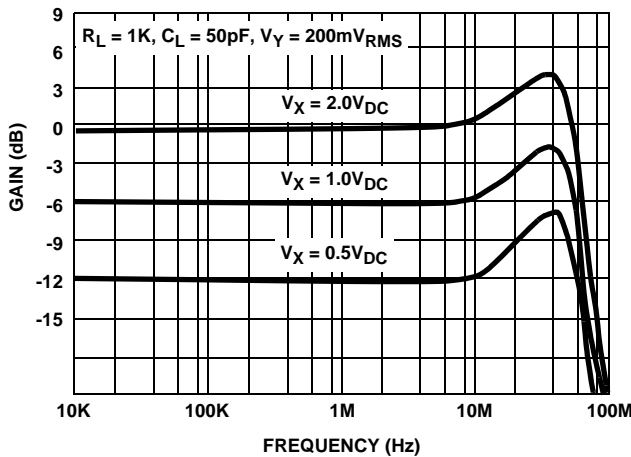

FIGURE 11. VARIOUS V_Y FREQUENCY RESPONSES

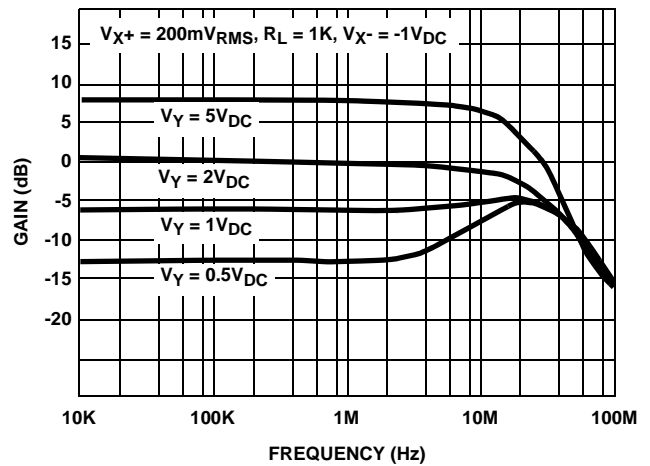

FIGURE 12. VARIOUS V_X FREQUENCY RESPONSES

Typical Performance Curves $V_S = \pm 15V$, $T_A = 25^\circ C$, See Test Circuit For Multiplier Configuration (Continued)

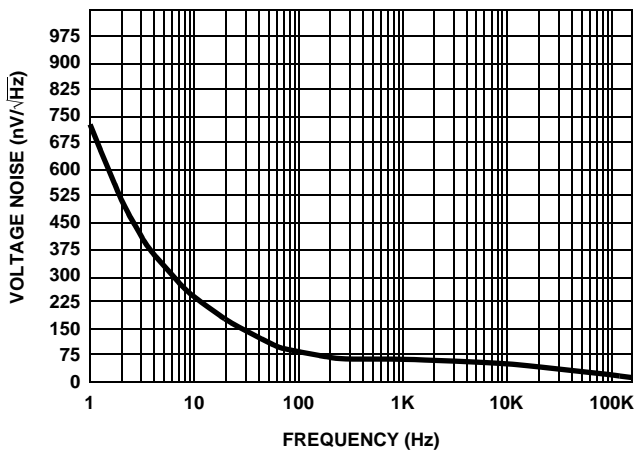

FIGURE 13. VOLTAGE NOISE DENSITY

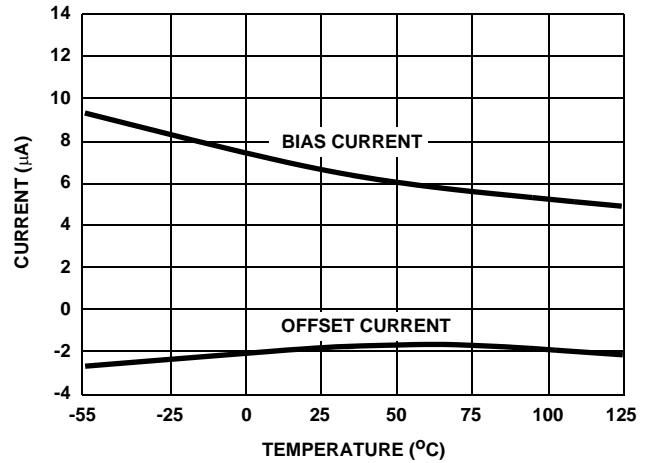

FIGURE 14. V_Y OFFSET AND BIAS CURRENT vs TEMPERATURE

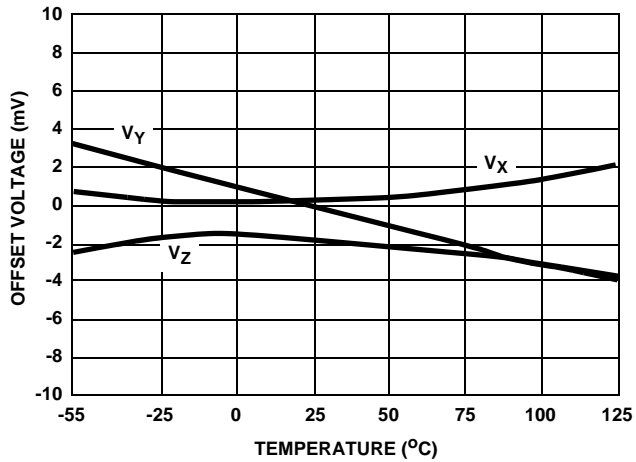

FIGURE 15. OFFSET VOLTAGE vs TEMPERATURE

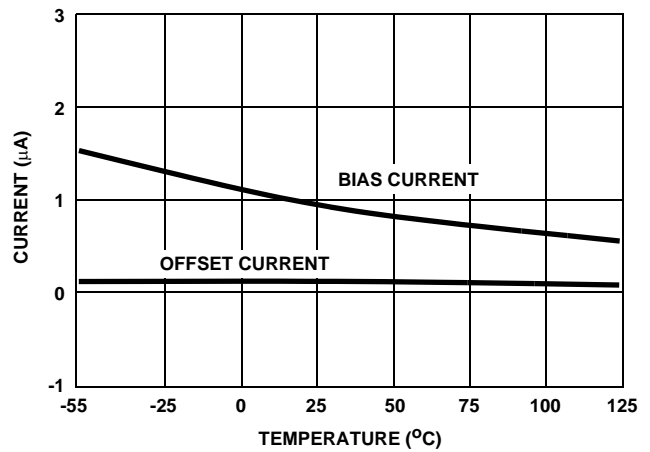

FIGURE 16. V_X OFFSET AND BIAS CURRENT vs TEMPERATURE

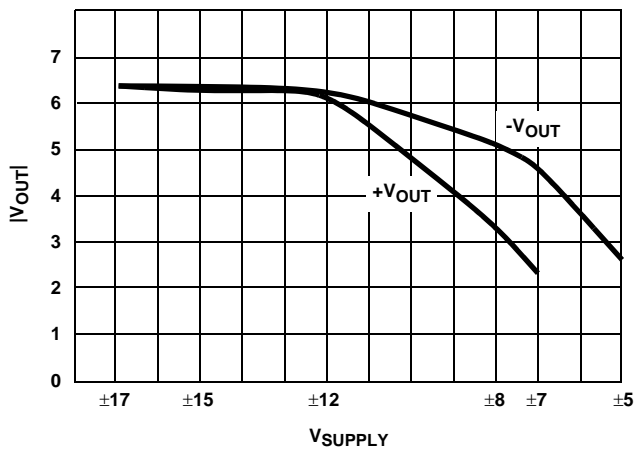

FIGURE 17. V_{OUT} vs V_{SUPPLY}

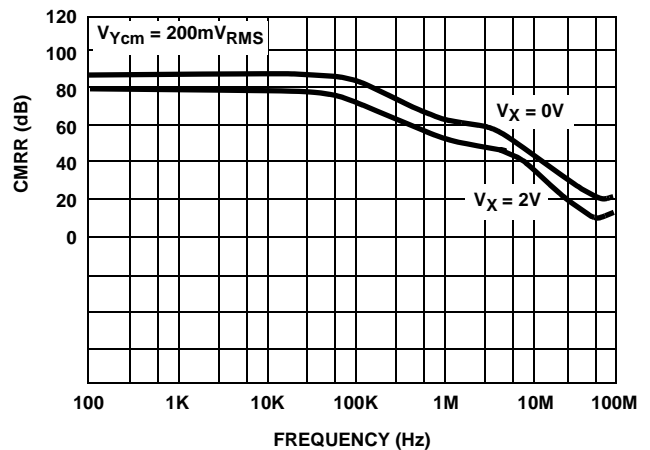

FIGURE 18. V_Y CMRR vs FREQUENCY

Typical Performance Curves $V_S = \pm 15V$, $T_A = 25^\circ C$, See Test Circuit For Multiplier Configuration (Continued)

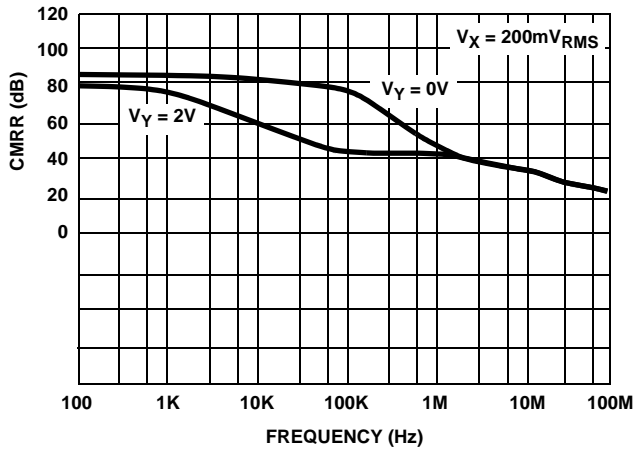

FIGURE 19. V_X COMMON MODE REJECTION RATIO vs FREQUENCY

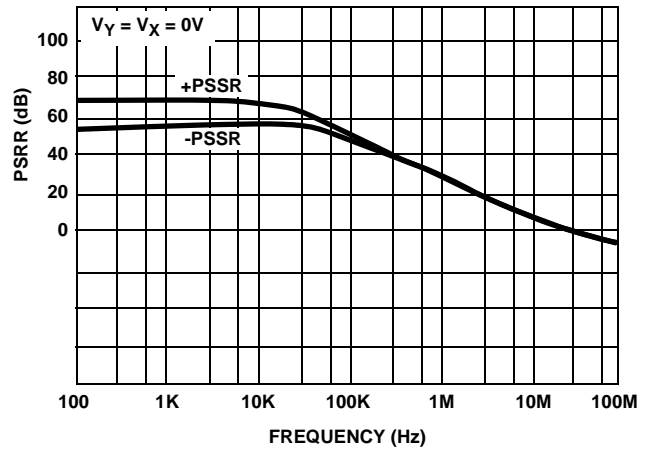

FIGURE 20. PSRR vs FREQUENCY

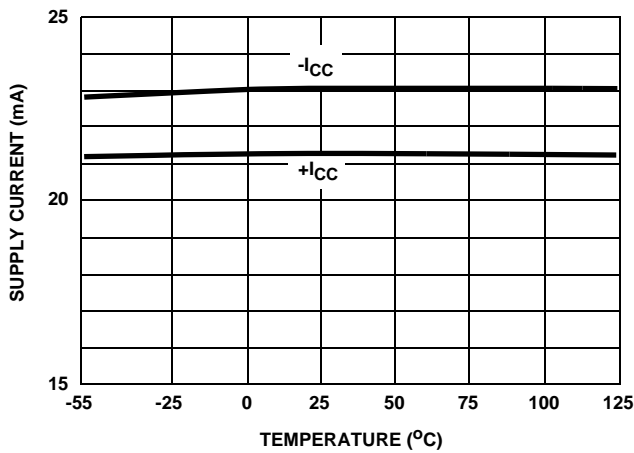

FIGURE 21. SUPPLY CURRENT vs TEMPERATURE

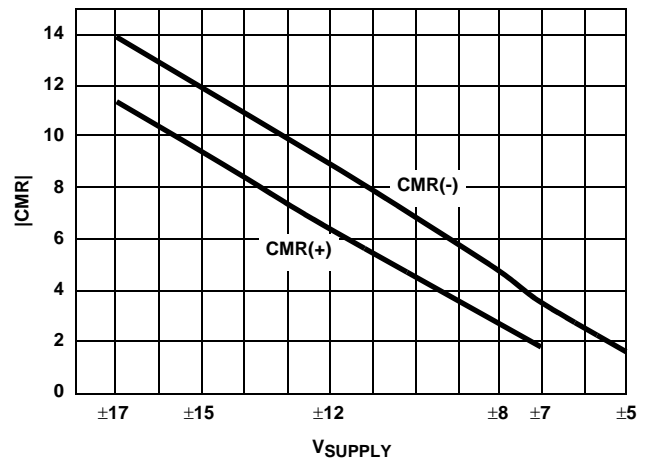

FIGURE 22. CMR vs V_{SUPPLY}

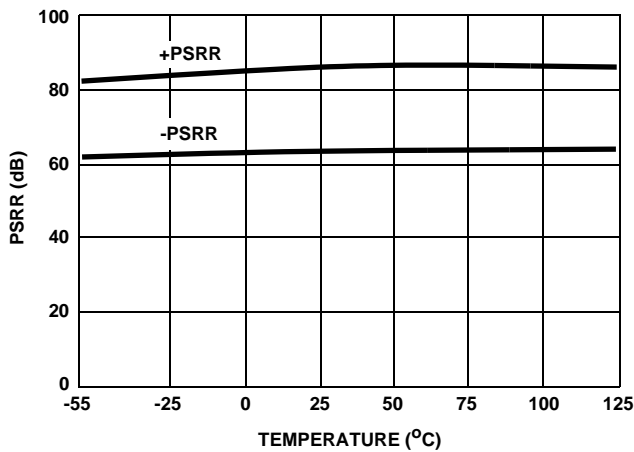

FIGURE 23. PSRR vs TEMPERATURE

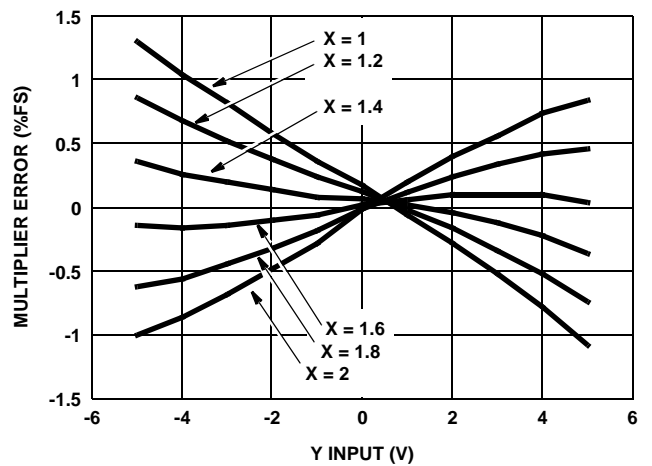

FIGURE 24. MULTIPLICATION ERROR vs V_Y

Typical Performance Curves $V_S = \pm 15V$, $T_A = 25^\circ C$, See Test Circuit For Multiplier Configuration (Continued)

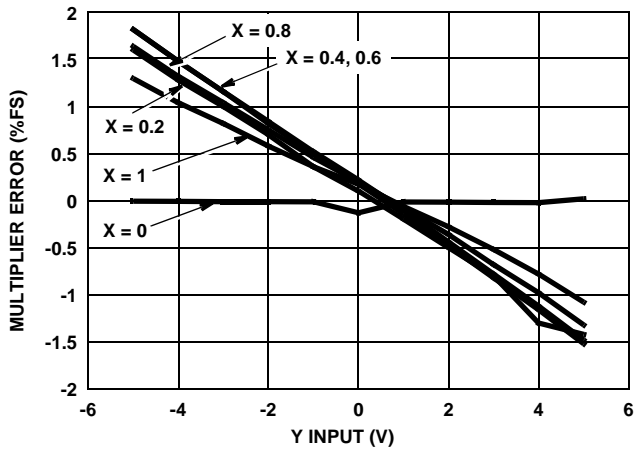

FIGURE 25.

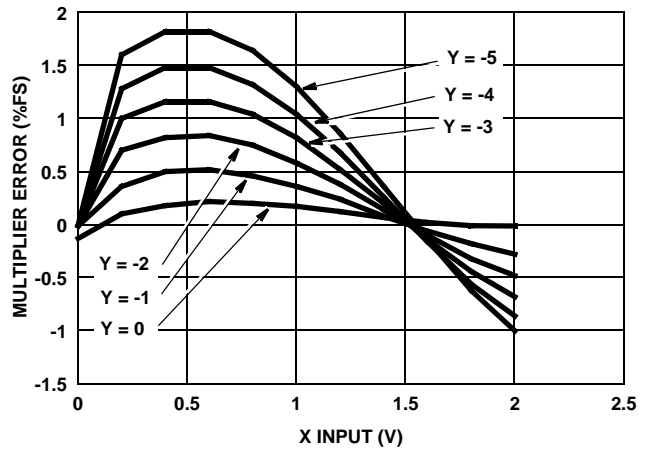

FIGURE 26.

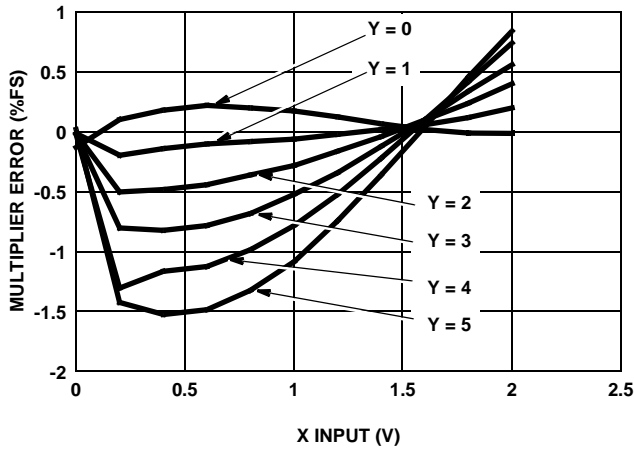

FIGURE 27.

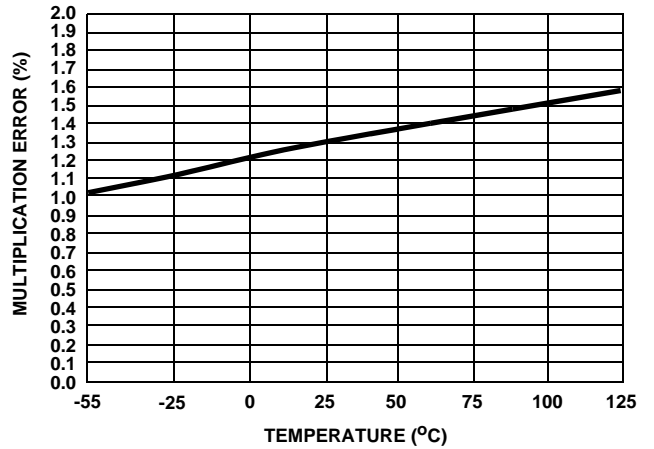

FIGURE 28. WORST CASE MULTIPLICATION ERROR vs TEMPERATURE

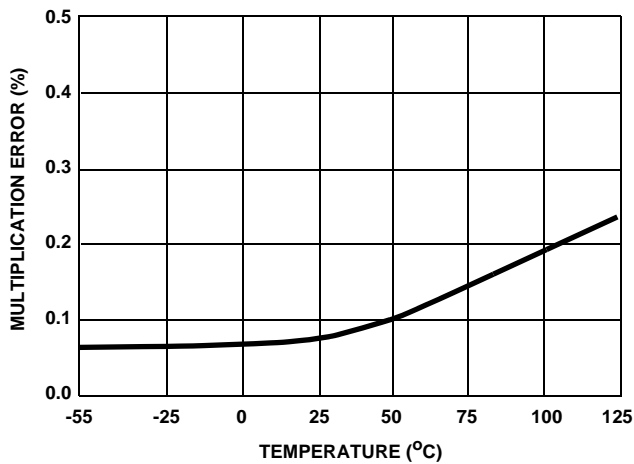

FIGURE 29. MULTIPLICATION ERROR vs TEMPERATURE

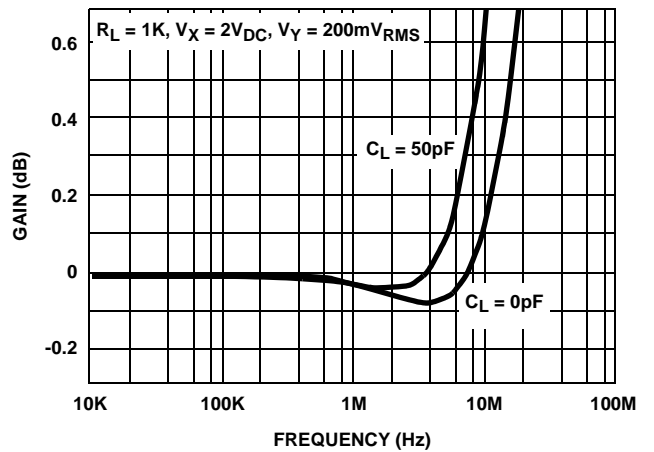

FIGURE 30. GAIN VARIATION vs FREQUENCY

Typical Performance Curves $V_S = \pm 15V$, $T_A = 25^\circ C$, See Test Circuit For Multiplier Configuration (Continued)

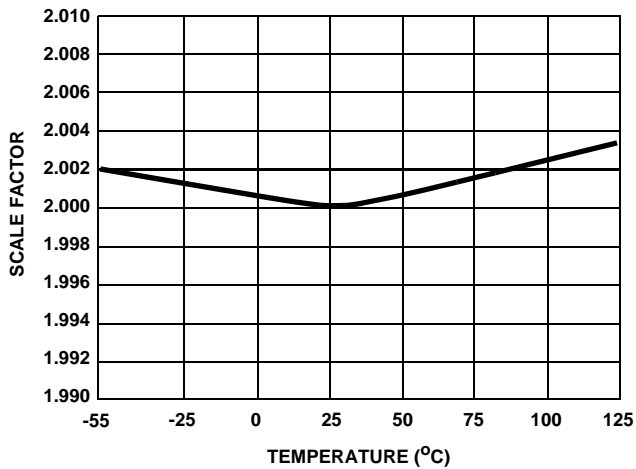

FIGURE 31. SCALE FACTOR vs TEMPERATURE

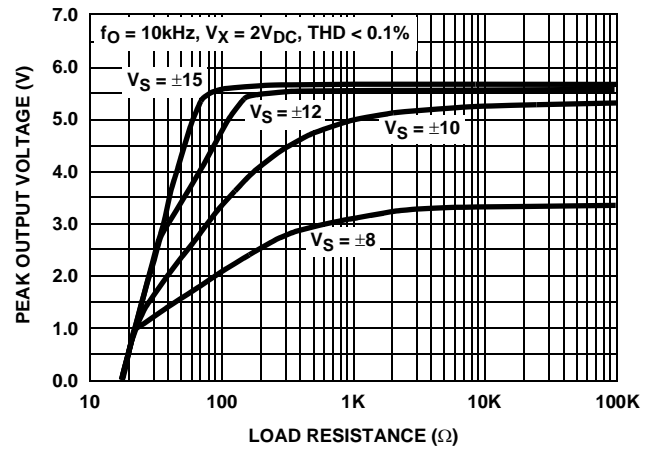

FIGURE 32. OUTPUT VOLTAGE SWING vs LOAD RESISTANCE

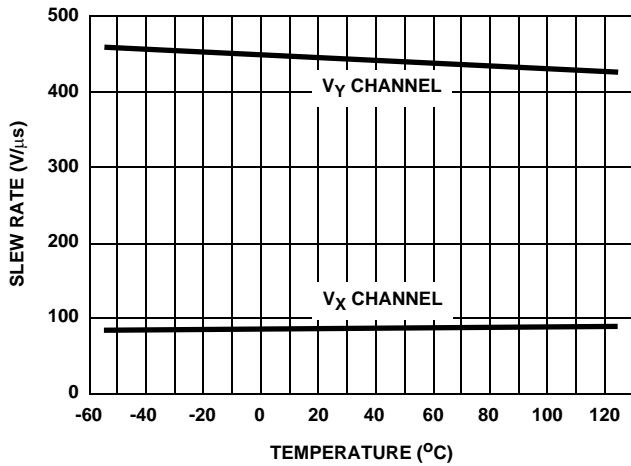

FIGURE 33. SLEW RATE vs TEMPERATURE

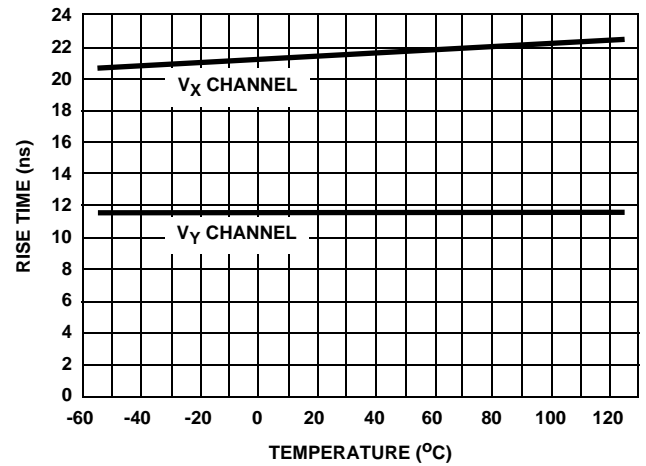

FIGURE 34. RISE TIME vs TEMPERATURE

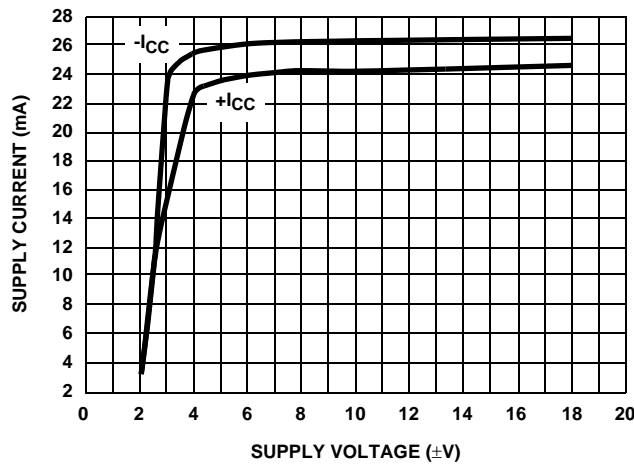

FIGURE 35. SUPPLY CURRENT vs SUPPLY VOLTAGE

HA-2546

Die Characteristics

DIE DIMENSIONS:

79.9 mils x 119.7 mils x 19 mils

METALLIZATION:

Type: Al, 1% CuI
 Thickness: $16\text{k}\text{\AA} \pm 2\text{k}\text{\AA}$

PASSIVATION:

Type: Nitride (Si_3N_4) over Silox (SiO_2 , 5% Phos)
 Silox Thickness: $12\text{k}\text{\AA} \pm 2\text{k}\text{\AA}$
 Nitride Thickness: $3.5\text{k}\text{\AA} \pm 2\text{k}\text{\AA}$

TRANSISTOR COUNT:

87

Metallization Mask Layout

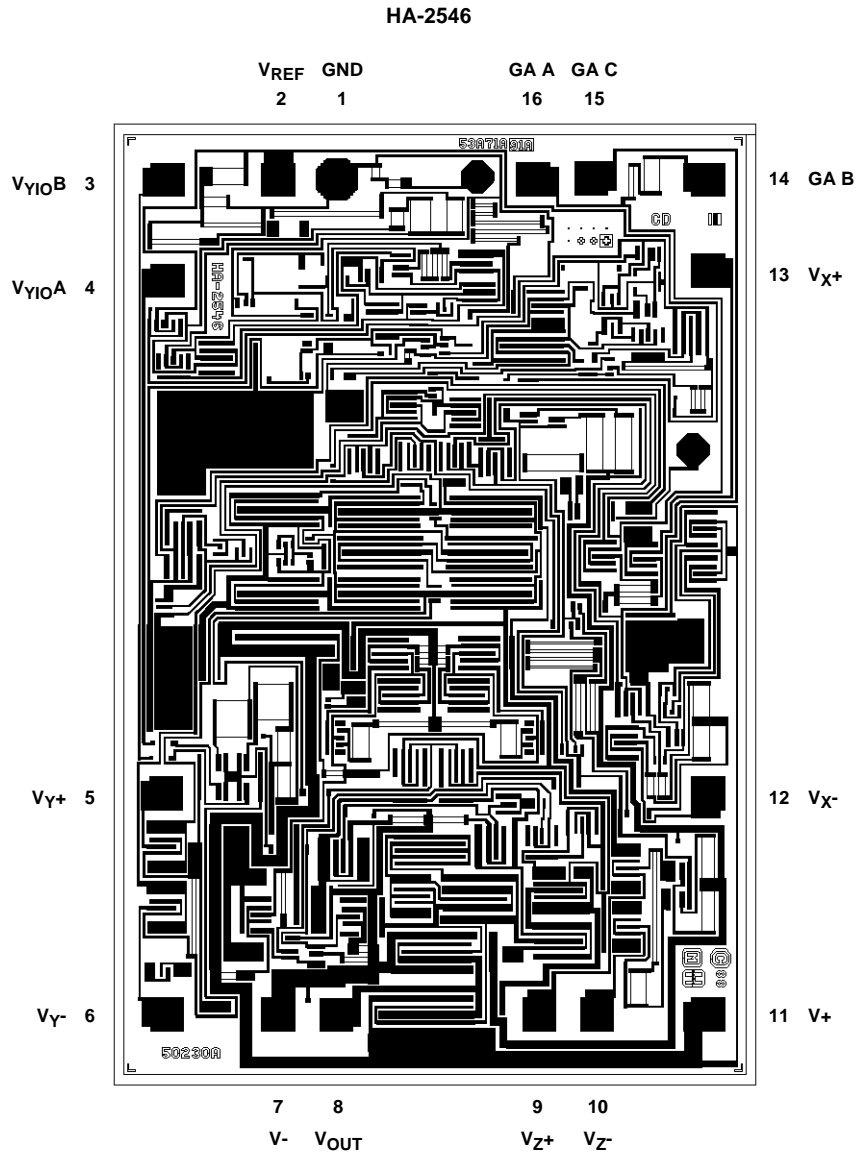

Small Outline Plastic Packages (SOIC)

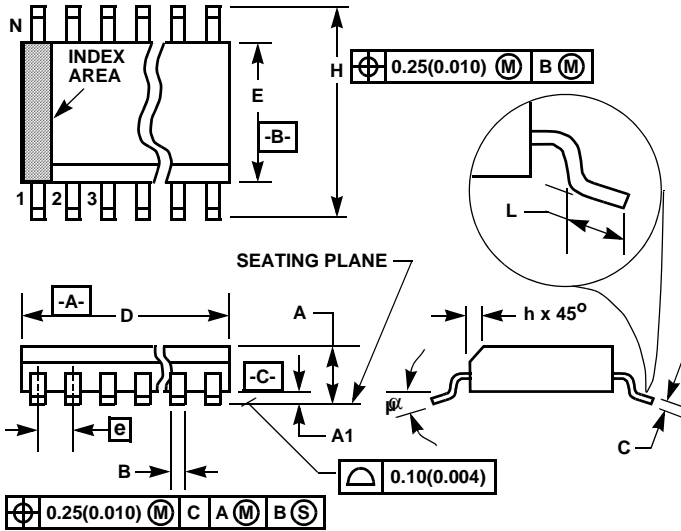

**M16.3 (JEDEC MS-013-AA ISSUE C)
16 LEAD WIDE BODY SMALL OUTLINE PLASTIC PACKAGE**

SYMBOL	INCHES		MILLIMETERS		NOTES
	MIN	MAX	MIN	MAX	
A	0.0926	0.1043	2.35	2.65	-
A1	0.0040	0.0118	0.10	0.30	-
B	0.013	0.0200	0.33	0.51	9
C	0.0091	0.0125	0.23	0.32	-
D	0.3977	0.4133	10.10	10.50	3
E	0.2914	0.2992	7.40	7.60	4
e	0.050 BSC		1.27 BSC		-
H	0.394	0.419	10.00	10.65	-
h	0.010	0.029	0.25	0.75	5
L	0.016	0.050	0.40	1.27	6
N	16		16		7
α	0°	8°	0°	8°	-

NOTES:

1. Symbols are defined in the "MO Series Symbol List" in Section 2.2 of Publication Number 95.
2. Dimensioning and tolerancing per ANSI Y14.5M-1982.
3. Dimension "D" does not include mold flash, protrusions or gate burrs. Mold flash, protrusion and gate burrs shall not exceed 0.15mm (0.006 inch) per side.
4. Dimension "E" does not include interlead flash or protrusions. Interlead flash and protrusions shall not exceed 0.25mm (0.010 inch) per side.
5. The chamfer on the body is optional. If it is not present, a visual index feature must be located within the crosshatched area.
6. "L" is the length of terminal for soldering to a substrate.
7. "N" is the number of terminal positions.
8. Terminal numbers are shown for reference only.
9. The lead width "B", as measured 0.36mm (0.014 inch) or greater above the seating plane, shall not exceed a maximum value of 0.61mm (0.024 inch)
10. Controlling dimension: MILLIMETER. Converted inch dimensions are not necessarily exact.

Rev. 0 12/93

All Intersil U.S. products are manufactured, assembled and tested utilizing ISO9000 quality systems. Intersil Corporation's quality certifications can be viewed at www.intersil.com/design/quality

Intersil products are sold by description only. Intersil Corporation reserves the right to make changes in circuit design, software and/or specifications at any time without notice. Accordingly, the reader is cautioned to verify that data sheets are current before placing orders. Information furnished by Intersil is believed to be accurate and reliable. However, no responsibility is assumed by Intersil or its subsidiaries for its use; nor for any infringements of patents or other rights of third parties which may result from its use. No license is granted by implication or otherwise under any patent or patent rights of Intersil or its subsidiaries.

For information regarding Intersil Corporation and its products, see www.intersil.com