

**QFN Packaged, +/-15kV ESD Protected,
+2.7V to +5.5V, 10Nanoamp, 250kbps,
RS-232 Transmitters/Receivers**

The Intersil ISL424XE devices are 2.7V to 5.5V powered RS-232 transmitters/receivers which meet EIA/TIA-232 and V.28/V.24 specifications, even at $V_{CC} = 3.0V$. Additionally, they provide $\pm 15kV$ ESD protection (IEC61000-4-2 Air Gap and Human Body Model) on transmitter outputs and receiver inputs (RS-232 pins). Targeted applications are PDAs, Palmtops, and notebook and laptop computers where the low operational, and even lower standby, power consumption is critical. Efficient on-chip charge pumps, coupled with manual and automatic powerdown functions, reduce the standby supply current to a 10nA trickle. Tiny 5mm x 5mm **Quad Flat No-Lead** (QFN) packaging and the use of small, low value capacitors ensure board space savings as well. Data rates greater than 250kbps are guaranteed at worst case load conditions.

The ISL424XE are 3 driver, 5 receiver devices that, coupled with the 5x5 QFN package, provide the industry's smallest, lowest power complete serial port suitable for PDAs, and laptop or notebook computers. The 5x5 QFN requires 60% less board area than a 28 lead TSSOP, and is nearly 20% thinner. The devices also include a noninverting always-active receiver for "wake-up" capability.

The **ISL4243E** features an **automatic powerdown** function that powers down the on-chip power-supply and driver circuits. This occurs when an attached peripheral device is shut off or the RS-232 cable is removed, conserving system power automatically without changes to the hardware or operating system. It powers up again when a valid RS-232 voltage is applied to any receiver input.

Table 1 summarizes the features of the ISL424XE, while Application Note AN9863 summarizes the features of each device comprising the 3V RS-232 family.

Features

- Parameters Fully Specified for 10% Tolerance Supplies and Full Industrial Temp Range
- Available in Small QFN (5mm x 5mm) Package which is 60% Smaller than a 28 Lead TSSOP
- ESD Protection for RS-232 I/O Pins to $\pm 15kV$ (IEC61000)
- Meets EIA/TIA-232 and V.28/V.24 Specifications at 3V
- RS-232 Compatible with $V_{CC} = 2.7V$
- On-Chip Voltage Converters Require Only Four External 0.1 μF Capacitors
- Manual and Automatic Powerdown Features
- Receiver Hysteresis For Improved Noise Immunity
- Guaranteed Minimum Data Rate 250kbps
- Wide Power Supply Range Single +2.7V to +5.5V
- Low Supply Current in Powerdown State. 10nA

Applications

- Any Space Constrained System Requiring RS-232 Ports
 - Battery Powered, Hand-Held, and Portable Equipment
 - Laptop Computers, Notebooks
 - PDAs and Palmtops, Data Cables
 - Cellular/Mobile Phones, Digital Cameras, GPS Receivers

Related Literature

- Technical Brief TB363 "Guidelines for Handling and Processing Moisture Sensitive Surface Mount Devices"
- "Technical Brief TB379 "Thermal Characterization of Packages for ICs"
- Technical Brief TB389 "PCB Land Pattern Design and Surface Mount Guidelines for QFN Packages"

TABLE 1. SUMMARY OF FEATURES

PART NUMBER	NO. OF Tx.	NO. OF Rx.	QFN PKG. AVAILABLE?	NO. OF MONITOR Rx. (ROUTB)	DATA RATE (kbps)	Rx. ENABLE FUNCTION?	READY OUTPUT?	MANUAL POWER-DOWN?	AUTOMATIC POWERDOWN FUNCTION?
ISL4241E	3	5	YES	2	250	YES	NO	YES	NO
ISL4243E	3	5	YES	1	250	NO	NO	YES	YES

Ordering Information

PART NO.	TEMP. RANGE (°C)	PACKAGE	PKG. NO.
ISL4241EIR	-40 to 85	32 Ld QFN	L32.5x5
ISL4241EIR-T	-40 to 85	Tape & Reel	L32.5x5
ISL4243EIR	-40 to 85	32 Ld QFN	L32.5x5
ISL4243EIR-T	-40 to 85	Tape & Reel	L32.5x5

Pinouts

ISL4241E (QFN)
TOP VIEW

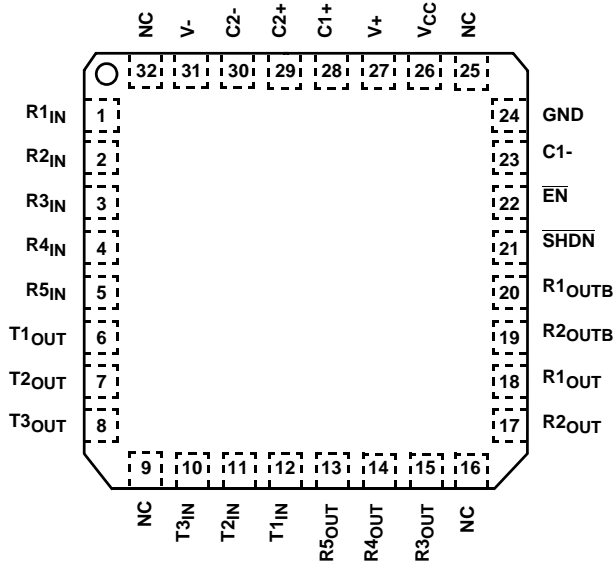

ISL4243E (QFN)
TOP VIEW

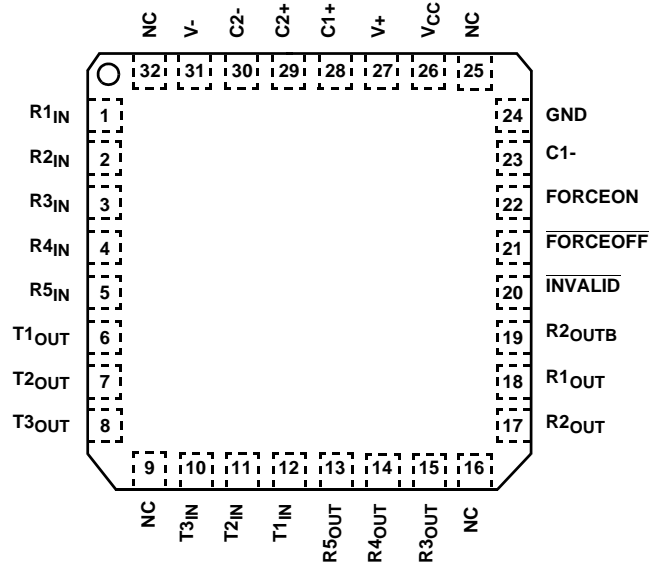

Pin Descriptions

PIN	FUNCTION
V _{CC}	System power supply input (2.7V to 5.5V).
V+	Internally generated positive transmitter supply (+5.5V).
V-	Internally generated negative transmitter supply (-5.5V).
GND	Ground connection.
C1+	External capacitor (voltage doubler) is connected to this lead.
C1-	External capacitor (voltage doubler) is connected to this lead.
C2+	External capacitor (voltage inverter) is connected to this lead.
C2-	External capacitor (voltage inverter) is connected to this lead.
T _{IN}	TTL/CMOS compatible transmitter Inputs.
T _{OUT}	±15kV ESD Protected, RS-232 level (nominally ±5.5V) transmitter outputs.
R _{IN}	±15kV ESD Protected, RS-232 compatible receiver inputs.
R _{OUT}	TTL/CMOS level receiver outputs.
R _{OUTB}	TTL/CMOS level, noninverting, always enabled receiver outputs.
INVALID	Active low output that indicates if no valid RS-232 levels are present on any receiver input.
FORCEOFF	Active low to shut down transmitters and on-chip power supply. This overrides any automatic circuitry and FORCEON (see Table 2).
FORCEON	Active high input to override automatic powerdown circuitry thereby keeping transmitters active. (FORCEOFF must be high).
EN	Active low receiver enable control.
SHDN	Active low input to shut down transmitters and on-board power supply, to place device in low power mode.
NC	No Connection

Typical Operating Circuits

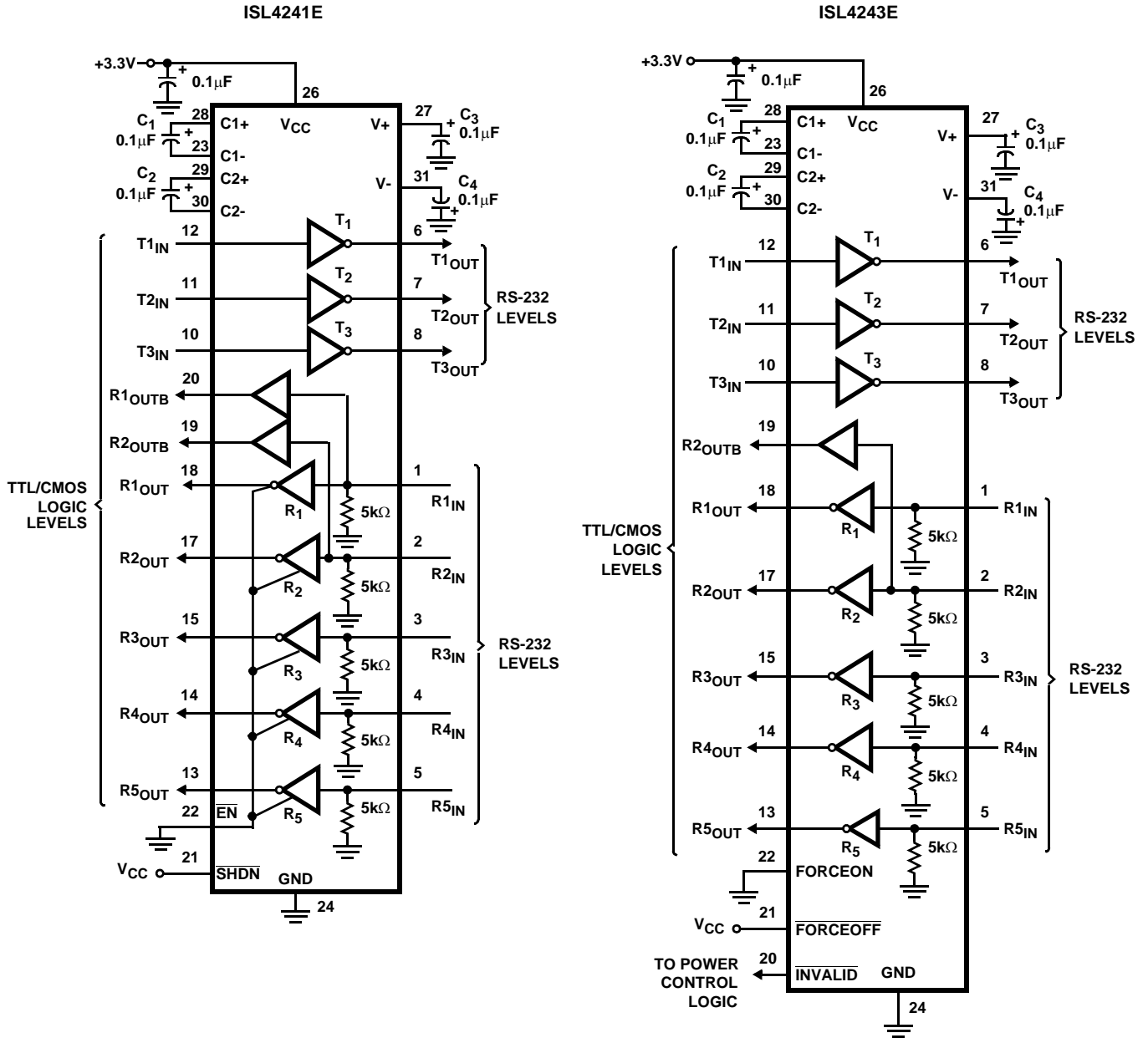

ISL4241E, ISL4243E

Absolute Maximum Ratings

V _{CC} to Ground	-0.3V to 6V
V ₊ to Ground	-0.3V to 7V
V ₋ to Ground	+0.3V to -7V
V ₊ to V ₋	14V
Input Voltages	
T _{IN} , FORCEOFF, FORCEON, EN, SHDN	-0.3V to 6V
R _{IN}	±25V
Output Voltages	
T _{OUT}	±13.2V
R _{OUT} , INVALID	-0.3V to V _{CC} +0.3V
Short Circuit Duration	
T _{OUT}	Continuous
ESD Rating	See Specification Table

Thermal Information

Thermal Resistance (Typical, Note 1)	θ _{JA} (°C/W)
32 Ld QFN Package	32
Moisture Sensitivity (see Technical Brief TB363)	
QFN Package	Level 1
Maximum Junction Temperature (Plastic Package)	150°C
Maximum Storage Temperature Range	-65°C to 150°C
Maximum Lead Temperature (Soldering 10s)	300°C

Operating Conditions

Temperature Range	ISL424XEIR	-40°C to 85°C
-------------------	------------	---------------

CAUTION: Stresses above those listed in "Absolute Maximum Ratings" may cause permanent damage to the device. This is a stress only rating and operation of the device at these or any other conditions above those indicated in the operational sections of this specification is not implied.

NOTE:

1. θ_{JA} is measured in free air with the component mounted on a high effective thermal conductivity test board with "direct attach" features. See Tech Brief TB379, and Tech Brief TB389.

Electrical Specifications Test Conditions: V_{CC} = 3V to 5.5V, C₁ - C₄ = 0.1µF; Unless Otherwise Specified.
Typicals are at T_A = 25°C

PARAMETER	TEST CONDITIONS	TEMP (°C)	MIN	TYP	MAX	UNITS
DC CHARACTERISTICS						
Operating Voltage Range		Full	2.7	-	5.5	V
Supply Current, Automatic Powerdown	All R _{IN} Open, FORCEON = GND, FORCEOFF = V _{CC} (ISL4243E Only)	25	-	3	300	nA
		Full	-	50	300	nA
Supply Current, Powerdown	All R _{IN} Open, FORCEOFF = SHDN = GND	25	-	3	300	nA
		Full	-	50	300	nA
Supply Current, Automatic Powerdown Disabled	All Outputs Unloaded, FORCEON = FORCEOFF = SHDN = V _{CC} , V _{CC} = 3.0V	25	-	0.3	1.0	mA
		Full	-	0.3	1.5	mA
LOGIC AND TRANSMITTER INPUTS AND RECEIVER OUTPUTS						
Input Logic Threshold Low	T _{IN} , FORCEON, FORCEOFF, EN, SHDN	Full	-	-	0.8	V
Input Logic Threshold High	T _{IN} , FORCEON, FORCEOFF, EN, SHDN, V _{CC} = 3.6V	Full	2.0	-	-	V
Input Leakage Current	T _{IN} , FORCEON, FORCEOFF, EN, SHDN	Full	-	±0.01	±1.0	µA
Output Leakage Current	FORCEOFF = GND (ISL4243E) or EN = V _{CC} (ISL4241E)	Full	-	±0.05	±10	µA
Transmitter Input Hysteresis		25	-	0.5	-	V
Output Voltage Low	I _{OUT} = 1.6mA	Full	-	-	0.4	V
Output Voltage High	I _{OUT} = -1.0mA	Full	V _{CC} -0.6	V _{CC} -0.1	-	V
AUTOMATIC POWERDOWN (ISL4243E Only, FORCEON = GND, FORCEOFF = V_{CC})						
Receiver Input Thresholds to Enable Transmitters	ISL4243E Powers Up (See Figure 7)	Full	-2.7	-	2.7	V
Receiver Input Thresholds to Disable Transmitters	ISL4243E Powers Down (See Figure 7)	Full	-0.3	-	0.3	V
INVALID Output Voltage Low	I _{OUT} = 1.6mA	Full	-	-	0.4	V
INVALID Output Voltage High	I _{OUT} = -1.0mA	Full	V _{CC} -0.6	-	-	V
Receiver Threshold to Transmitters Enabled Delay (t _{WU})		Full	-	20	100	µs
Receiver Positive or Negative Threshold to INVALID High Delay (t _{INVH})		25	-	0.5	1	µs
		Full	-	0.9	1.5	µs

ISL4241E, ISL4243E

Electrical Specifications Test Conditions: $V_{CC} = 3V$ to $5.5V$, $C_1 - C_4 = 0.1\mu F$; Unless Otherwise Specified.
Typicals are at $T_A = 25^\circ C$ (Continued)

PARAMETER	TEST CONDITIONS	TEMP (°C)	MIN	TYP	MAX	UNITS	
Receiver Positive or Negative Threshold to INVALID Low Delay (t_{INVL})		25	-	30	50	μs	
		Full	-	40	60	μs	
RECEIVER INPUTS							
Input Voltage Range		Full	-25	-	25	V	
Input Threshold Low	$V_{CC} = 3.0V$	Full	-	1.0	0.6	V	
Input Threshold High	$V_{CC} = 3.6V$	Full	2.4	1.5	-	V	
Input Hysteresis		25	-	0.5	-	V	
Input Resistance		Full	3	5	7	k Ω	
TRANSMITTER OUTPUTS							
Output Voltage Swing	All Transmitter Outputs Loaded with $3k\Omega$ to Ground	Full	± 5.0	± 5.4	-	V	
Output Resistance	$V_{CC} = V+ = V- = 0V$, Transmitter Output = $\pm 2V$	Full	300	10M	-	Ω	
Output Short-Circuit Current		Full	-	± 35	± 60	mA	
Output Leakage Current	$V_{OUT} = \pm 12V$, $V_{CC} = 0V$ or $3V$ to $5.5V$, Automatic Powerdown or $FORCEOFF = SHDN = GND$	Full	-	-	± 25	μA	
TIMING CHARACTERISTICS							
Maximum Data Rate	$R_L = 3k\Omega$, $C_L = 1000pF$, One Transmitter Switching	Full	250	500	-	kbps	
Receiver Propagation Delay	Receiver Input to Receiver Output, $C_L = 150pF$	t_{PHL}	25	-	0.15	0.3	μs
			Full	-	0.2	0.35	μs
		t_{PLH}	25	-	0.3	0.5	μs
			Full	-	0.35	0.55	μs
Receiver Skew	$t_{PHL} - t_{PLH}$, $C_L = 150pF$	25	-	120	250	ns	
		Full	-	150	300	ns	
Transmitter Propagation Delay	Transmitter Input to Transmitter Output, $C_L = 1000pF$, $R_L = 3k\Omega$	t_{PHL}	25	-	0.75	1	μs
			Full	-	0.85	1.1	μs
		t_{PLH}	25	-	0.8	1	μs
			Full	-	0.9	1.1	μs
Transmitter Skew	$t_{PHL} - t_{PLH}$ (Note 2), $R_L = 3k\Omega$, $C_L = 1000pF$	25	-	50	200	ns	
		Full	-	100	250	ns	
Receiver Output Enable Time	Normal Operation, $R_L = 1k\Omega$ to $0.5V_{CC}$, $C_L = 15pF$	25	-	200	350	ns	
		Full	-	200	400	ns	
Receiver Output Disable Time	Normal Operation, $R_L = 1k\Omega$ to $0.5V_{CC}$, $C_L = 15pF$	25	-	350	500	ns	
		Full	-	400	600	ns	
Transmitter Output Enable Time	Normal Operation, $R_L = 3k\Omega$, $C_L = 1000pF$	25	-	25	40	μs	
		Full	-	30	50	μs	
Transmitter Output Disable Time	Normal Operation, $R_L = 3k\Omega$, $C_L = 1000pF$	25	-	2.5	4	μs	
		Full	-	2.7	4	μs	
Transition Region Slew Rate	$V_{CC} = 3V$ to $3.6V$, $R_L = 3k\Omega$ to $7k\Omega$, Measured From $3V$ to $-3V$ or $-3V$ to $3V$	$C_L = 150pF$ to $2500pF$	25	4	9	30	V/ μs
			Full	4	8	30	V/ μs
		$C_L = 150pF$ to $1000pF$	25	6	11	30	V/ μs
			Full	6	10	30	V/ μs

Electrical Specifications Test Conditions: $V_{CC} = 3V$ to $5.5V$, $C_1 - C_4 = 0.1\mu F$; Unless Otherwise Specified.
Typicals are at $T_A = 25^\circ C$ (Continued)

PARAMETER	TEST CONDITIONS	TEMP (°C)	MIN	TYP	MAX	UNITS
ESD PERFORMANCE						
RS-232 Pins (T_{OUT} , R_{IN})	Human Body Model	25	-	± 15	-	kV
	IEC61000-4-2 Contact Discharge	25	-	± 8	-	kV
	IEC61000-4-2 Air Gap Discharge	25	-	± 15	-	kV
All Other Pins	Human Body Model	25	-	± 2	-	kV

NOTE:

- Transmitter skew is measured at the transmitter zero crossing points.

Detailed Description

The ISL424XE operate from a single +2.7V to +5.5V supply, guarantee a 250kbps minimum data rate, require only four small external 0.1μF capacitors, feature low power consumption, and meet all EIA RS-232C and V.28 specifications even with $V_{CC} = 3.0V$. The circuit is divided into three sections: The charge pump, the transmitters, and the receivers.

Charge-Pump

Intersil's new ISL424XE devices utilize regulated on-chip dual charge pumps as voltage doublers, and voltage inverters to generate $\pm 5.5V$ transmitter supplies from a V_{CC} supply as low as 3.0V. This allows them to maintain RS-232 compliant output levels over the $\pm 10\%$ tolerance range of 3.3V powered systems. The efficient on-chip power supplies require only four small, external 0.1μF capacitors for the voltage doubler and inverter functions. The charge pumps operate discontinuously (i.e., they turn off as soon as the V+ and V- supplies are pumped up to the nominal values), resulting in significant power savings.

Transmitters

The transmitters are proprietary, low dropout, inverting drivers that translate TTL/CMOS inputs to EIA/TIA-232 output levels. Coupled with the on-chip $\pm 5.5V$ supplies, these transmitters deliver true RS-232 levels over a wide range of single supply system voltages.

All transmitter outputs disable and assume a high impedance state when the device enters the powerdown mode (see Table 2). These outputs may be driven to $\pm 12V$ when disabled.

The devices guarantee a 250kbps data rate for full load conditions ($3k\Omega$ and $1000pF$), $V_{CC} \geq 3.0V$, with one transmitter operating at full speed. Under more typical conditions of $V_{CC} \geq 3.3V$, $R_L = 3k\Omega$, and $C_L = 250pF$, one transmitter easily operates at 900kbps.

Transmitter inputs float if left unconnected, and may cause I_{CC} increases. Connect unused inputs to GND for the best performance.

Receivers

All the ISL424XE devices contain standard inverting receivers that three-state via the \overline{EN} or $\overline{FORCEOFF}$ control lines. Additionally, the ISL424XE products include noninverting (monitor) receivers (denoted by the R_{OUTB} label) that are always active, regardless of the state of any control lines. All the receivers convert RS-232 signals to CMOS output levels and accept inputs up to $\pm 25V$ while presenting the required $3k\Omega$ to $7k\Omega$ input impedance (see Figure 1) even if the power is off ($V_{CC} = 0V$). The receivers' Schmitt trigger input stage uses hysteresis to increase noise immunity and decrease errors due to slow input signal transitions.

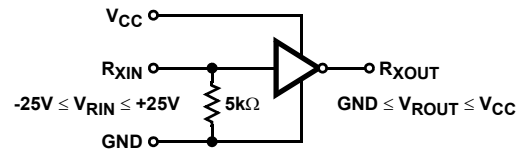

FIGURE 1. INVERTING RECEIVER CONNECTIONS

The ISL4241E inverting receivers disable only when \overline{EN} is driven high. ISL4243E receivers disable during forced (manual) powerdown, but not during automatic powerdown (see Table 2).

ISL424XE monitor receivers remain active even during manual powerdown, making them extremely useful for Ring Indicator monitoring. Standard receivers driving powered down peripherals must be disabled to prevent current flow through the peripheral's protection diodes (see Figures 2 and 3). This renders them useless for wake up functions, but the corresponding monitor receiver can be dedicated to this task as shown in Figure 3.

Low Power Operation

These 3V devices require a nominal supply current of 0.3mA, even at $V_{CC} = 5.5V$, during normal operation (not in powerdown mode). This is considerably less than the 5mA to 11mA current required by comparable 5V RS-232 devices, allowing users to reduce system power simply by switching to this new family.

TABLE 2. POWERDOWN AND ENABLE LOGIC TRUTH TABLE

RS-232 SIGNAL PRESENT AT RECEIVER INPUT?	$\overline{\text{SHDN}}$ OR FORCEOFF INPUT	FORCEON INPUT	$\overline{\text{EN}}$ INPUT	TRANSMITTER OUTPUTS	RECEIVER OUTPUTS	R _{OUTB} OUTPUTS	$\overline{\text{INVALID}}$ OUTPUT	MODE OF OPERATION
ISL4241E								
N.A.	L	N.A.	L	High-Z	Active	Active	N.A.	Manual Powerdown
N.A.	L	N.A.	H	High-Z	High-Z	Active	N.A.	Manual Powerdown w/Rcvr. Disabled
N.A.	H	N.A.	L	Active	Active	Active	N.A.	Normal Operation
N.A.	H	N.A.	H	Active	High-Z	Active	N.A.	Normal Operation w/Rcvr. Disabled
ISL4243E								
NO	H	H	N.A.	Active	Active	Active	L	Normal Operation (Auto Powerdown Disabled)
YES	H	L	N.A.	Active	Active	Active	H	Normal Operation (Auto Powerdown Enabled)
NO	H	L	N.A.	High-Z	Active	Active	L	Powerdown Due to Auto Powerdown Logic
YES	L	X	N.A.	High-Z	High-Z	Active	H	Manual Powerdown
NO	L	X	N.A.	High-Z	High-Z	Active	L	Manual Powerdown

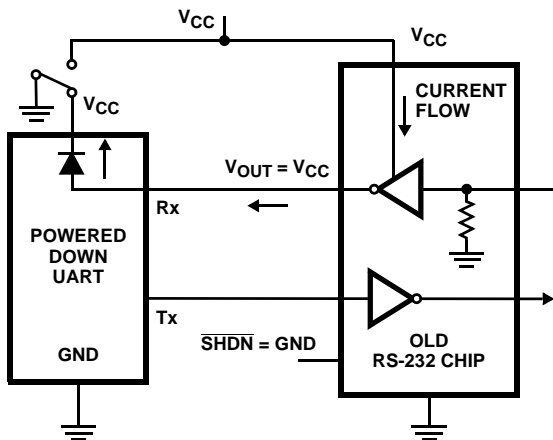

FIGURE 2. POWER DRAIN THROUGH POWERED DOWN PERIPHERAL

Powerdown Functionality

The already low current requirement drops significantly when the device enters powerdown mode. In powerdown, supply current drops to 10nA, because the on-chip charge pump turns off (V+ collapses to V_{CC}, V- collapses to GND), and the transmitter outputs three-state. Inverting receiver outputs disable only in manual powerdown; refer to Table 2 for details. This micro-power mode makes the ISL424XE ideal for battery powered and portable applications.

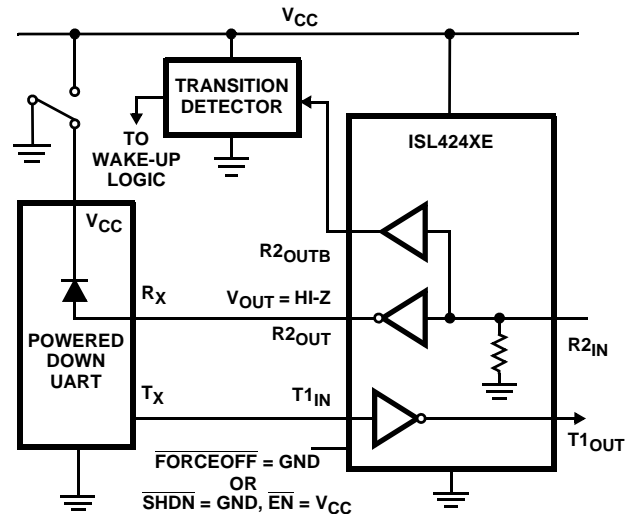

FIGURE 3. DISABLED RECEIVERS PREVENT POWER DRAIN

Software Controlled (Manual) Powerdown

Most devices in the ISL424XE family provide pins that allow the user to force the IC into the low power, standby state.

On the ISL4241E, the powerdown control is via a simple shutdown ($\overline{\text{SHDN}}$) pin. Driving this pin high enables normal operation, while driving it low forces the IC into its powerdown state. Connect $\overline{\text{SHDN}}$ to V_{CC} if the powerdown function isn't needed. Note that all the receiver outputs remain enabled during shutdown (see Table 2). For the lowest power consumption during powerdown, the receivers

should also be disabled by driving the $\overline{\text{EN}}$ input high (see next section, and Figures 2 and 3).

The ISL4243E utilize a two pin approach where the FORCEON and $\overline{\text{FORCEOFF}}$ inputs determine the IC's mode. For always enabled operation, FORCEON and $\overline{\text{FORCEOFF}}$ are both strapped high. To switch between active and powerdown modes, under logic or software control, only the $\overline{\text{FORCEOFF}}$ input need be driven. The FORCEON state isn't critical, as $\overline{\text{FORCEOFF}}$ dominates over FORCEON. Nevertheless, if strictly manual control over powerdown is desired, the user must strap FORCEON high to disable the automatic powerdown circuitry. ISL4243E inverting (standard) receiver outputs also disable when the device is in manual powerdown, thereby eliminating the possible current path through a shutdown peripheral's input protection diode (see Figures 2 and 3).

Connecting $\overline{\text{FORCEOFF}}$ and FORCEON together disables the automatic powerdown feature, enabling them to function as a manual SHUTDOWN input (see Figure 4).

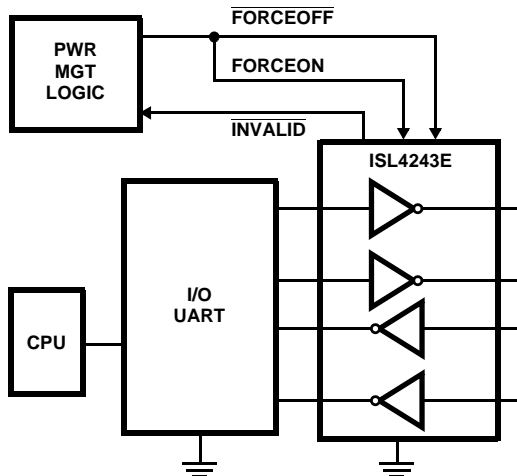

FIGURE 4. CONNECTIONS FOR MANUAL POWERDOWN WHEN NO VALID RECEIVER SIGNALS ARE PRESENT

With any of the above control schemes, the time required to exit powerdown, and resume transmission is only 100 μs . A mouse, or other application, may need more time to wake up from shutdown. If automatic powerdown is being utilized, the RS-232 device will reenter powerdown if valid receiver levels aren't reestablished within 30 μs of the ISL4243E powering up. Figure 5 illustrates a circuit that keeps the ISL4243E from initiating automatic powerdown for 100ms after powering up. This gives the slow-to-wake peripheral circuit time to reestablish valid RS-232 output levels.

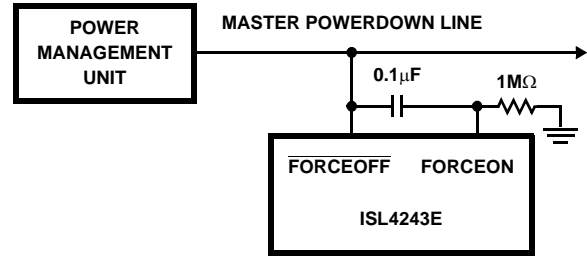

FIGURE 5. CIRCUIT TO PREVENT AUTO POWERDOWN FOR 100ms AFTER FORCED POWERUP

$\overline{\text{INVALID}}$ Output (ISL4243E Only)

The $\overline{\text{INVALID}}$ output always indicates whether or not a valid RS-232 signal (see Figure 6) is present at any of the receiver inputs (see Table 2), giving the user an easy way to determine when the interface block should power down. Invalid receiver levels occur whenever the driving peripheral's outputs are shut off (powered down) or when the RS-232 interface cable is disconnected. In the case of a disconnected interface cable where all the receiver inputs are floating (but pulled to GND by the internal receiver pull down resistors), the $\overline{\text{INVALID}}$ logic detects the invalid levels and drives the output low. The power management logic then uses this indicator to power down the interface block. Reconnecting the cable restores valid levels at the receiver inputs, $\overline{\text{INVALID}}$ switches high, and the power management logic wakes up the interface block. $\overline{\text{INVALID}}$ can also be used to indicate the DTR or RING INDICATOR signal, as long as the other receiver inputs are floating, or driven to GND (as in the case of a powered down driver).

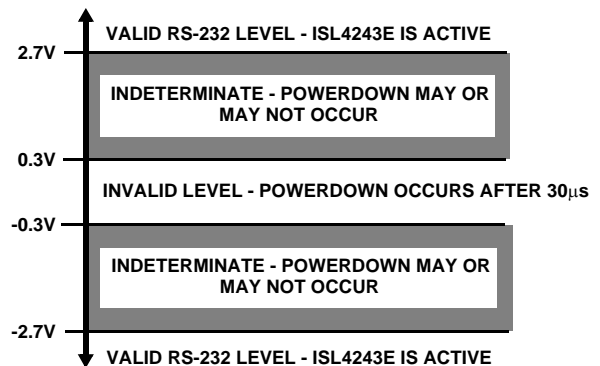

FIGURE 6. DEFINITION OF VALID RS-232 RECEIVER LEVELS

$\overline{\text{INVALID}}$ switches low after invalid levels have persisted on all of the receiver inputs for more than 30 μs (see Figure 7). $\overline{\text{INVALID}}$ switches back high 1 μs after detecting a valid RS-232 level on a receiver input. $\overline{\text{INVALID}}$ operates in all modes (forced or automatic powerdown, or forced on), so it is also useful for systems employing manual powerdown circuitry. When automatic powerdown is utilized, $\overline{\text{INVALID}} = 0$ indicates that the ISL4243E is in powerdown mode.

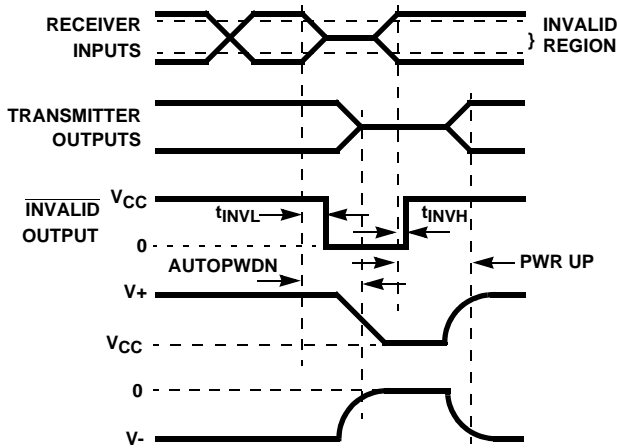

FIGURE 7. AUTOMATIC POWERDOWN AND $\overline{\text{INVALID}}$ TIMING DIAGRAMS

Automatic Powerdown (ISL4243E Only)

Even greater power savings is available by using the ISL4243E which features an *automatic* powerdown function. When no valid RS-232 voltages (see Figure 5) are sensed on any receiver input for 30μs, the charge pump and transmitters powerdown, thereby reducing supply current to 10nA. Invalid receiver levels occur whenever the driving peripheral's outputs are shut off (powered down) or when the RS-232 interface cable is disconnected. The ISL4243E powers back up whenever it detects a valid RS-232 voltage level on any receiver input. This automatic powerdown feature provides additional system power savings without changes to the existing operating system.

Automatic powerdown operates when the FORCEON input is low, and the $\overline{\text{FORCEOFF}}$ input is high. Tying FORCEON high disables automatic powerdown, but manual powerdown is always available via the overriding $\overline{\text{FORCEOFF}}$ input. Table 2 summarizes the automatic powerdown functionality.

The time to recover from automatic powerdown mode is typically 100μs.

Capacitor Selection

The charge pumps require 0.1μF, or greater, capacitors for proper operation. Increasing the capacitor values (by a factor of 2) reduces ripple on the transmitter outputs and slightly reduces power consumption.

When using minimum required capacitor values, make sure that capacitor values do not degrade excessively with temperature. If in doubt, use capacitors with a larger nominal value. The capacitor's equivalent series resistance (ESR) usually rises at low temperatures and it influences the amount of ripple on V₊ and V₋.

Power Supply Decoupling

In most circumstances a 0.1μF bypass capacitor is adequate. In applications that are particularly sensitive to

power supply noise, decouple V_{CC} to ground with a capacitor of the same value as the charge-pump capacitor C₁. Connect the bypass capacitor as close as possible to the IC.

Transmitter Outputs when Exiting Powerdown

Figure 8 shows the response of two transmitter outputs when exiting powerdown mode. As they activate, the two transmitter outputs properly go to opposite RS-232 levels, with no glitching, ringing, nor undesirable transients. Each transmitter is loaded with 3kΩ in parallel with 2500pF. Note that the transmitters enable only when the magnitude of the supplies exceed approximately 3V.

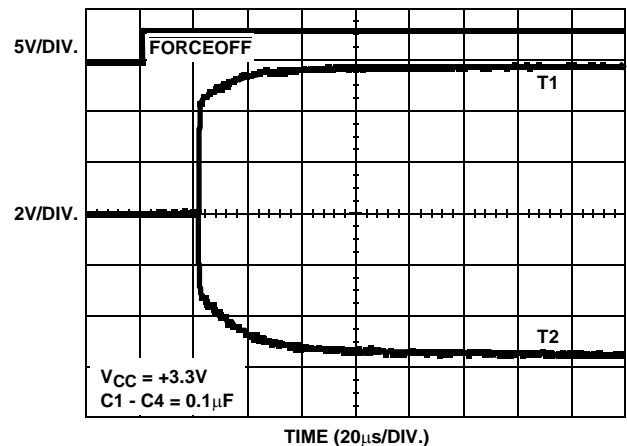

FIGURE 8. TRANSMITTER OUTPUTS WHEN EXITING POWERDOWN

Operation Down to 2.7V

ISL424XE transmitter outputs meet RS-562 levels (±3.7V), at the full data rate, with V_{CC} as low as 2.7V. RS-562 levels typically ensure inter operability with RS-232 devices.

High Data Rates

The ISL424XE maintain the RS-232 ±5V minimum transmitter output voltages even at high data rates. Figure 9 details a transmitter loopback test circuit, and Figure 10 illustrates the loopback test result at 120kbps. For this test, all transmitters were simultaneously driving RS-232 loads in parallel with 1000pF, at 120kbps. Figure 11 shows the loopback results for a single transmitter driving 1000pF and an RS-232 load at 250kbps. The static transmitters were also loaded with an RS-232 receiver.

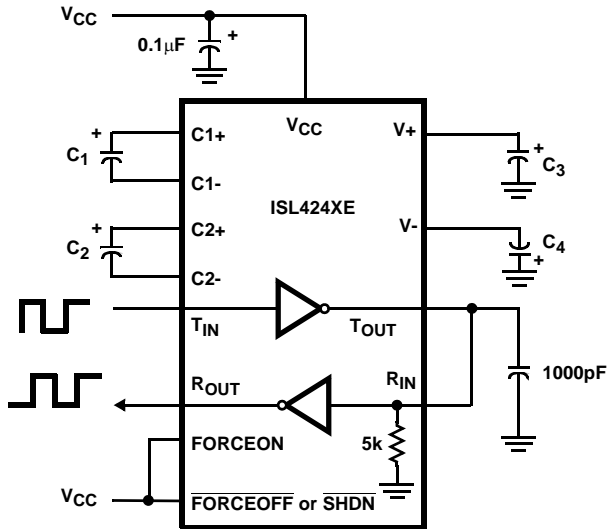

FIGURE 9. TRANSMITTER LOOPBACK TEST CIRCUIT

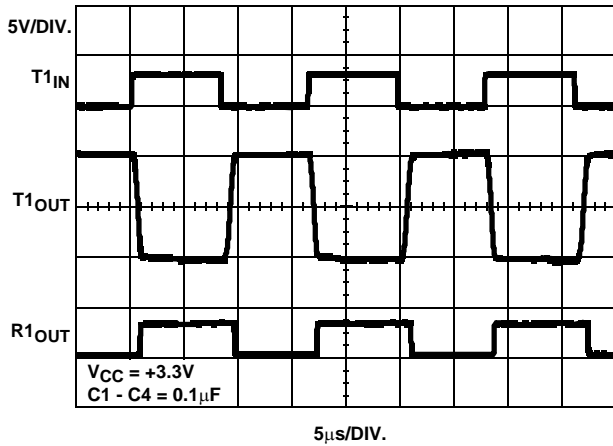

FIGURE 10. LOOPBACK TEST AT 120kbps

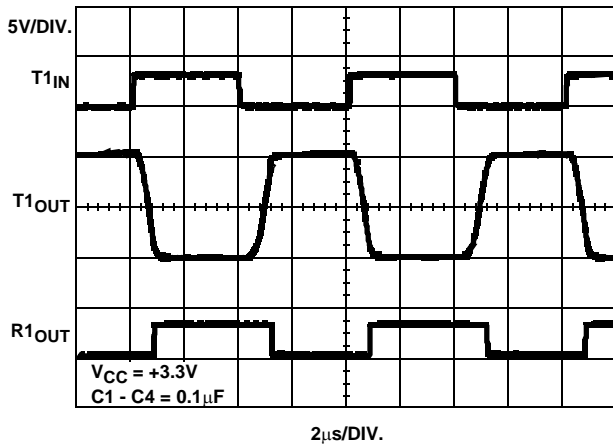

FIGURE 11. LOOPBACK TEST AT 250kbps

Interconnection with 3V and 5V Logic

The ISL424XE directly interface with 5V CMOS and TTL logic families. Nevertheless, with the ISL424XE at 3.3V, and the logic supply at 5V, AC, HC, and CD4000 outputs can drive ISL424XE inputs, but ISL424XE outputs do not reach the minimum V_{IH} for these logic families. See Table 3 for more information.

TABLE 3. LOGIC FAMILY COMPATIBILITY WITH VARIOUS SUPPLY VOLTAGES

SYSTEM POWER-SUPPLY VOLTAGE (V)	V _{CC} SUPPLY VOLTAGE (V)	COMPATIBILITY
3.3	3.3	Compatible with all CMOS families.
5	5	Compatible with all TTL and CMOS logic families.
5	3.3	Compatible with ACT and HCT CMOS, and with TTL. ISL424XE outputs are incompatible with AC, HC, and CD4000 CMOS inputs.

±15kV ESD Protection

All pins on ISL424XE devices include ESD protection structures, but the RS-232 pins (transmitter outputs and receiver inputs) incorporate advanced structures which allow them to survive ESD events up to ±15kV. The RS-232 pins are particularly vulnerable to ESD damage because they typically connect to an exposed port on the exterior of the finished product. Simply touching the port pins, or connecting a cable, can cause an ESD event that might destroy unprotected ICs. These new ESD structures protect the device whether or not it is powered up, protect without allowing any latchup mechanism to activate, and don't interfere with RS-232 signals as large as ±25V.

Human Body Model (HBM) Testing

As the name implies, this test method emulates the ESD event delivered to an IC during human handling. The tester delivers the charge through a 1.5kΩ current limiting resistor, making the test less severe than the IEC61000 test which utilizes a 330Ω limiting resistor. The HBM method determines an ICs ability to withstand the ESD transients typically present during handling and manufacturing. Due to the random nature of these events, each pin is tested with respect to all other pins. The RS-232 pins on "E" family devices can withstand HBM ESD events to ±15kV.

IEC61000-4-2 Testing

The IEC61000 test method applies to finished equipment, rather than to an individual IC. Therefore, the pins most likely to suffer an ESD event are those that are exposed to the outside world (the RS-232 pins in this case), and the IC is tested in its typical application configuration (power applied) rather than testing each pin-to-pin combination. The lower current limiting resistor coupled with the larger charge

storage capacitor yields a test that is much more severe than the HBM test. The extra ESD protection built into this device's RS-232 pins allows the design of equipment meeting level 4 criteria without the need for additional board level protection on the RS-232 port.

AIR-GAP DISCHARGE TEST METHOD

For this test method, a charged probe tip moves toward the IC pin until the voltage arcs to it. The current waveform delivered to the IC pin depends on approach speed, humidity, temperature, etc., so it is difficult to obtain

repeatable results. The "E" device RS-232 pins withstand ±15kV air-gap discharges.

CONTACT DISCHARGE TEST METHOD

During the contact discharge test, the probe contacts the tested pin before the probe tip is energized, thereby eliminating the variables associated with the air-gap discharge. The result is a more repeatable and predictable test, but equipment limits prevent testing devices at voltages higher than ±8kV. All "E" family devices survive ±8kV contact discharges on the RS-232 pins.

Typical Performance Curves $V_{CC} = 3.3V, T_A = 25^{\circ}C$

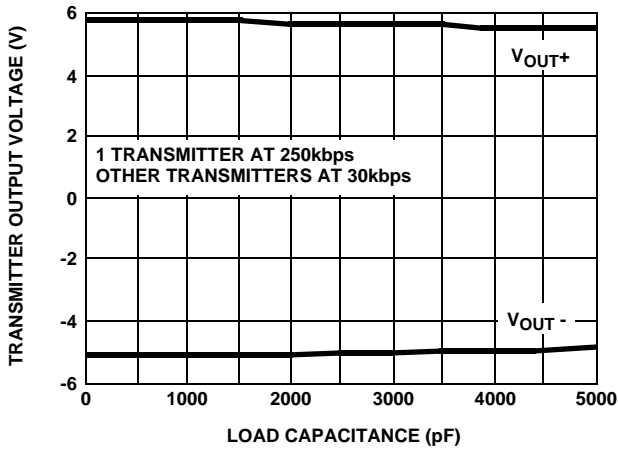

FIGURE 12. TRANSMITTER OUTPUT VOLTAGE vs LOAD CAPACITANCE

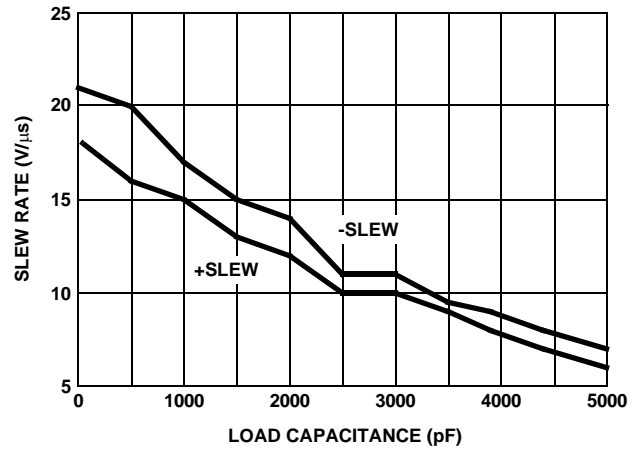

FIGURE 13. SLEW RATE vs LOAD CAPACITANCE

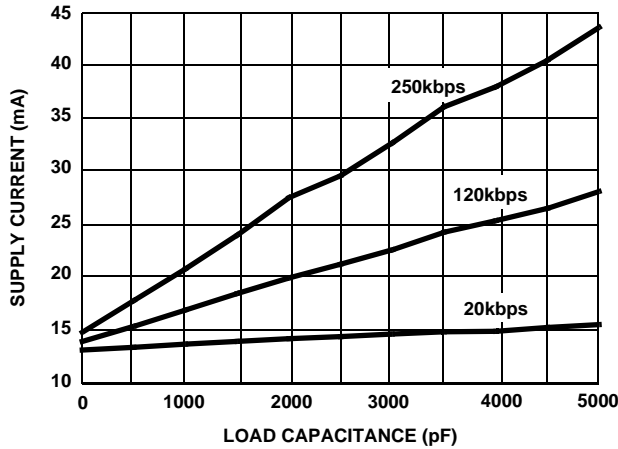

FIGURE 14. SUPPLY CURRENT vs LOAD CAPACITANCE WHEN TRANSMITTING DATA

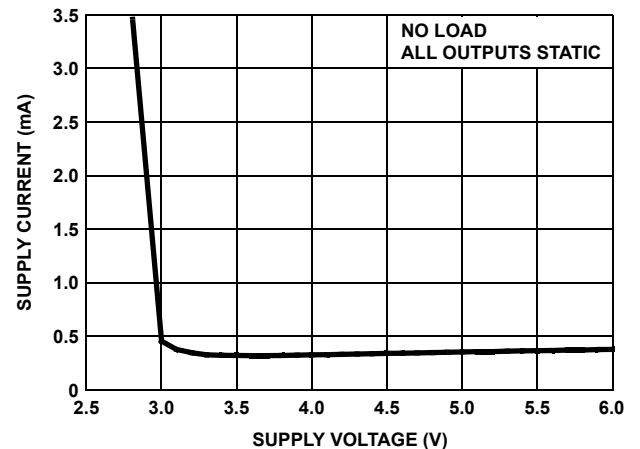

FIGURE 15. SUPPLY CURRENT vs SUPPLY VOLTAGE

Die Characteristics

SUBSTRATE POTENTIAL (POWERED UP):

GND

TRANSISTOR COUNT:

ISL424XE: 464

PROCESS:

Si Gate CMOS

**Quad Flat No-Lead Plastic Package (QFN)
Micro Lead Frame Plastic Package (MLFP)**

L32.5x5

32 LEAD QUAD FLAT NO-LEAD PLASTIC PACKAGE
(COMPLIANT TO JEDEC MO-220VHHD-2 ISSUE C)

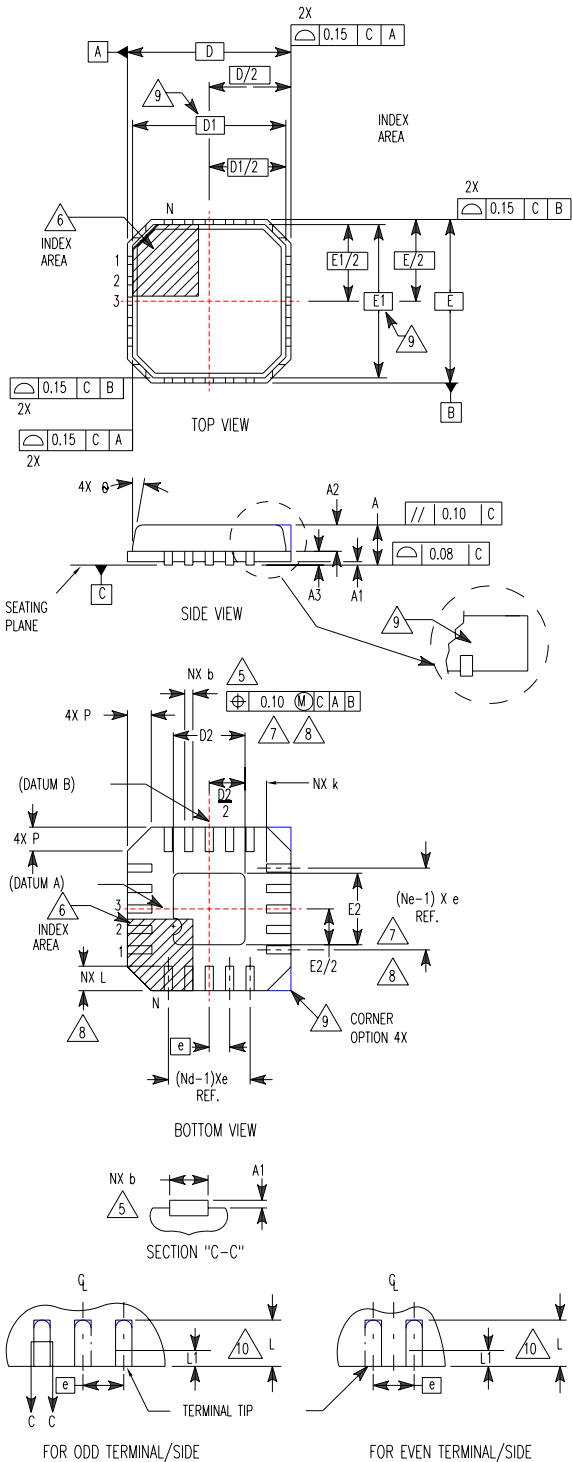

SYMBOL	MILLIMETERS			NOTES
	MIN	NOMINAL	MAX	
A	0.80	0.90	1.00	-
A1	-	-	0.05	-
A2	-	-	1.00	9
A3	0.20 REF			9
b	0.18	0.23	0.30	5,8
D	5.00 BSC			-
D1	4.75 BSC			9
D2	2.95	3.10	3.25	7,8
E	5.00 BSC			-
E1	4.75 BSC			9
E2	2.95	3.10	3.25	7,8
e	0.50 BSC			-
k	0.25	-	-	-
L	0.30	0.40	0.50	8
L1	-	-	0.15	10
N	32			2
Nd	8			3
Ne	8	8	-	3
P	-	-	0.60	9
θ	-	-	12	9

Rev. 1 10/02

NOTES:

1. Dimensioning and tolerancing conform to ASME Y14.5-1994.
2. N is the number of terminals.
3. Nd and Ne refer to the number of terminals on each D and E.
4. All dimensions are in millimeters. Angles are in degrees.
5. Dimension b applies to the metallized terminal and is measured between 0.15mm and 0.30mm from the terminal tip.
6. The configuration of the pin #1 identifier is optional, but must be located within the zone indicated. The pin #1 identifier may be either a mold or mark feature.
7. Dimensions D2 and E2 are for the exposed pads which provide improved electrical and thermal performance.
8. Nominal dimensions are provided to assist with PCB Land Pattern Design efforts, see Intersil Technical Brief TB389.
9. Features and dimensions A2, A3, D1, E1, P & θ are present when Anvil singulation method is used and not present for saw singulation.
10. Depending on the method of lead termination at the edge of the package, a maximum 0.15mm pull back (L1) maybe present. L minus L1 to be equal to or greater than 0.3mm.

All Intersil U.S. products are manufactured, assembled and tested utilizing ISO9000 quality systems.

Intersil Corporation's quality certifications can be viewed at www.intersil.com/design/quality

Intersil products are sold by description only. Intersil Corporation reserves the right to make changes in circuit design, software and/or specifications at any time without notice. Accordingly, the reader is cautioned to verify that data sheets are current before placing orders. Information furnished by Intersil is believed to be accurate and reliable. However, no responsibility is assumed by Intersil or its subsidiaries for its use; nor for any infringements of patents or other rights of third parties which may result from its use. No license is granted by implication or otherwise under any patent or patent rights of Intersil or its subsidiaries.

For information regarding Intersil Corporation and its products, see www.intersil.com