

**+/-15kV ESD Protected, +3V to +5.5V,
1Microamp, 250kbps, RS-232
Transmitters/Receivers**

The Intersil ISL83220E is a 3.0V to 5.5V powered RS-232 transmitter/receiver which meets EIA/TIA-232 and V.28/V.24 specifications, even at $V_{CC} = 3.0V$. Additionally, it provides $\pm 15kV$ ESD protection (IEC 1000-4-2 Air Gap and Human Body Model) on transmitter outputs and receiver inputs (RS-232 pins). Targeted applications are PDAs, Palmtops, and notebook and laptop computers where the low operational, and even lower standby, power consumption is critical. Efficient on-chip charge pumps, coupled with a manual powerdown function, reduce the standby supply current to a $1\mu A$ trickle. Small footprint packaging, and the use of small, low value capacitors ensure board space savings as well. Data rates greater than 250kbps are guaranteed at worst case load conditions. This family is fully compatible with 3.3V only systems, mixed 3.3V and 5.0V systems, and 5.0V only systems.

Table 1 summarizes the features of the ISL83320E, while Application Note AN9863 summarizes the features of each device comprising the ICL32XXE 3V family.

Features

- ESD Protection for RS-232 I/O Pins to $\pm 15kV$ (IEC1000)
- Drop in Replacement for SP3220E
- Meets EIA/TIA-232 and V.28/V.24 Specifications at 3V
- Interoperable with RS-232 down to $V_{CC} = 2.7V$
- Latch-Up Free
- On-Chip Voltage Converters Require Only Four External $0.1\mu F$ Capacitors
- Manual Powerdown Feature with Receivers Active
- Separate Receiver Enable Pin
- R_X and T_X Hysteresis For Improved Noise Immunity
- Guaranteed Minimum Data Rate 250kbps
- Guaranteed Minimum Slew Rate $6V/\mu s$
- Wide Power Supply Range Single +3V to +5.5V
- Low Supply Current in Powerdown State. $1\mu A$

Applications

- Any System Requiring RS-232 Communication Ports
 - Battery Powered, Hand-Held, and Portable Equipment
 - Laptop Computers, Notebooks, Palmtops
 - Modems, Printers and other Peripherals
 - Digital Cameras
 - Cellular/Mobile Phones

Related Literature

- Technical Brief TB363 "Guidelines for Handling and Processing Moisture Sensitive Surface Mount Devices (SMDs)"

TABLE 1. SUMMARY OF FEATURES

PART NUMBER	NO. OF Tx.	NO. OF Rx.	NO. OF MONITOR Rx. (R_{OUTB})	DATA RATE (kbps)	Rx. ENABLE FUNCTION?	READY OUTPUT?	MANUAL POWER-DOWN?	AUTOMATIC POWERDOWN FUNCTION?
ISL83220E	1	1	0	250	YES	NO	YES	NO

Ordering Information

(NOTE 1) PART NO.	TEMP. RANGE (°C)	PACKAGE	PKG. NO.
ISL83220ECB	0 to 70	16 Ld SOIC	M16.3
ISL83220EIB	-40 to 85	16 Ld SOIC	M16.3
ISL83220ECA	0 to 70	16 Ld SSOP	M16.209
ISL83220EIA	-40 to 85	16 Ld SSOP	M16.209
ISL83220ECV	0 to 70	16 Ld TSSOP	M16.173
ISL83220EIV	-40 to 85	16 Ld TSSOP	M16.173

NOTE:

1. Most surface mount devices are available on tape and reel; add "-T" to suffix.

Pinout

ISL83220E (SOIC, SSOP, TSSOP)
TOP VIEW

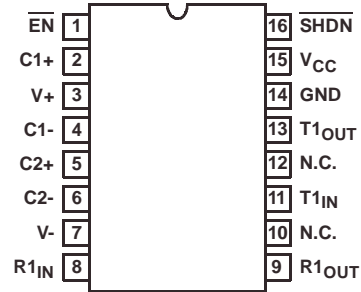

Pin Descriptions

PIN	FUNCTION
V _{CC}	System power supply input (3.0V to 5.5V).
V+	Internally generated positive transmitter supply (+5.5V).
V-	Internally generated negative transmitter supply (-5.5V).
GND	Ground connection.
C1+	External capacitor (voltage doubler) is connected to this lead.
C1-	External capacitor (voltage doubler) is connected to this lead.
C2+	External capacitor (voltage inverter) is connected to this lead.
C2-	External capacitor (voltage inverter) is connected to this lead.
T _{IN}	TTL/CMOS compatible transmitter Inputs.
T _{OUT}	±15kV ESD Protected, RS-232 level (nominally ±5.5V) transmitter outputs.
R _{IN}	±15kV ESD Protected, RS-232 compatible receiver inputs.
R _{OUT}	TTL/CMOS level receiver outputs.
EN	Active low receiver enable control; doesn't disable R _{OUTB} outputs.
SHDN	Active low input shuts down transmitters and on-board power supply, to place device in low power mode.
N.C.	No internal connection.

Typical Operating Circuit

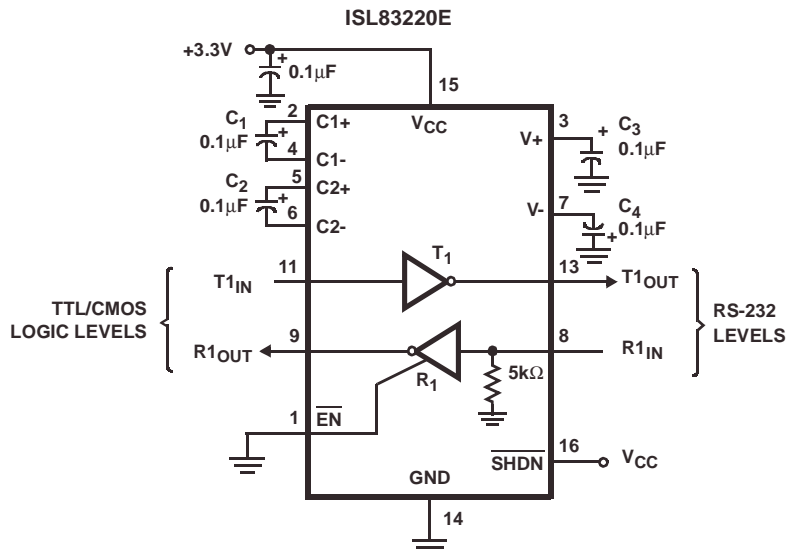

Absolute Maximum Ratings

V _{CC} to Ground	-0.3V to 6V
V+ to Ground	-0.3V to 7V
V- to Ground	+0.3V to -7V
V+ to V-	14V
Input Voltages	
T _{IN} , EN, SHDN	-0.3V to 6V
R _{IN}	±25V
Output Voltages	
T _{OUT}	±13.2V
R _{OUT}	-0.3V to V _{CC} +0.3V
Short Circuit Duration	
T _{OUT}	Continuous
ESD Rating	See Specification Table

Thermal Information

Thermal Resistance (Typical, Note 2)	θ _{JA} (°C/W)
16 Ld Wide SOIC Package	100
16 Ld SSOP Package	135
16 Ld TSSOP Package	145
Moisture Sensitivity (see Technical Brief TB363)	
All Packages	Level 1
Maximum Junction Temperature (Plastic Package)	150°C
Maximum Storage Temperature Range	-65°C to 150°C
Maximum Lead Temperature (Soldering 10s) (Lead Tips Only)	300°C

Operating Conditions

Temperature Range	
ISL83220ECX	0°C to 70°C
ISL83220EIX	-40°C to 85°C

CAUTION: Stresses above those listed in "Absolute Maximum Ratings" may cause permanent damage to the device. This is a stress only rating and operation of the device at these or any other conditions above those indicated in the operational sections of this specification is not implied.

NOTE:

- θ_{JA} is measured with the component mounted on a low effective thermal conductivity test board in free air. See Tech Brief TB379 for details.

Electrical Specifications

Test Conditions: V_{CC} = 3V to 5.5V, C₁ - C₄ = 0.1µF; Unless Otherwise Specified.
Typicals are at T_A = 25°C

PARAMETER	TEST CONDITIONS	TEMP (°C)	MIN	TYP	MAX	UNITS
DC CHARACTERISTICS						
Supply Current	All Outputs Unloaded, SHDN = V _{CC}	V _{CC} = 3.15V	25	-	0.3	1.0 mA
Supply Current, Powerdown	SHDN = GND		25	-	1.0	10 µA
LOGIC AND TRANSMITTER INPUTS AND RECEIVER OUTPUTS						
Input Logic Threshold Low	T _{IN} , EN, SHDN		Full	-	-	0.8 V
Input Logic Threshold High	T _{IN} , EN, SHDN	V _{CC} = 3.3V	Full	2.0	-	- V
		V _{CC} = 5.0V	Full	2.4	-	- V
Transmitter Input Hysteresis		25	-	0.3		V
Input Leakage Current	T _{IN} , EN, SHDN		Full	-	±0.01	±1.0 µA
Output Leakage Current	EN = V _{CC}		Full	-	±0.05	±10 µA
Output Voltage Low	I _{OUT} = 1.6mA		Full	-	-	0.4 V
Output Voltage High	I _{OUT} = -1.0mA		Full	V _{CC} -0.6	V _{CC} -0.1	- V
TRANSMITTER OUTPUTS						
Output Voltage Swing	All Transmitter Outputs Loaded with 3kΩ to Ground		Full	±5.0	±5.4	- V
Output Resistance	V _{CC} = V+ = V- = 0V, Transmitter Output = ±2V		Full	300	10M	- Ω
Output Short-Circuit Current	V _{OUT} = 0V		Full	-	±35	±60 mA
Output Leakage Current	V _{OUT} = ±12V, V _{CC} = 0V or 3V to 5.5V, SHDN = GND		Full	-	-	±25 µA
RECEIVER INPUTS						
Input Voltage Range			Full	-25	-	25 V
Input Threshold Low	V _{CC} = 3.3V		Full	0.6	1.2	- V
	V _{CC} = 5.0V		Full	0.8	1.5	- V

Electrical Specifications Test Conditions: $V_{CC} = 3V$ to $5.5V$, $C_1 - C_4 = 0.1\mu F$; Unless Otherwise Specified.
Typicals are at $T_A = 25^\circ C$ (Continued)

PARAMETER	TEST CONDITIONS	TEMP (°C)	MIN	TYP	MAX	UNITS	
Input Threshold High	$V_{CC} = 3.3V$	Full	-	1.5	2.4	V	
	$V_{CC} = 5.0V$	Full	-	1.8	2.4	V	
Input Hysteresis		25	-	0.3	-	V	
Input Resistance		Full	3	5	7	k Ω	
TIMING CHARACTERISTICS							
Maximum Data Rate	$R_L = 3k\Omega$, $C_L = 1000pF$, One Transmitter Switching	Full	250	500	-	kbps	
Transmitter Propagation Delay	Transmitter Input to Transmitter Output, $R_L = 3k\Omega$, $C_L = 1000pF$	t_{PHL}	25	-	1.0	-	μs
		t_{PLH}	25	-	1.0	-	μs
Receiver Propagation Delay	Receiver Input to Receiver Output, $C_L = 150pF$	t_{PHL}	25	-	0.20	-	μs
		t_{PLH}	25	-	0.30	-	μs
Receiver Output Enable Time	Normal Operation	25	-	200	-	ns	
Receiver Output Disable Time	Normal Operation	25	-	200	-	ns	
Transmitter Skew	$t_{PHL} - t_{PLH}$ (Note 3)	25	-	100	500	ns	
Receiver Skew	$t_{PHL} - t_{PLH}$	Full	-	100	1000	ns	
Transition Region Slew Rate	$V_{CC} = 3.3V$, $R_L = 3k\Omega$ to $7k\Omega$, Measured From $3V$ to $-3V$ or $-3V$ to $3V$	$C_L = 150pF$ to $2500pF$	25	4	-	30	V/ μs
		$C_L = 150pF$ to $1000pF$	25	6	-	30	V/ μs
ESD PERFORMANCE							
RS-232 Pins (T_{OUT} , R_{IN})	Human Body Model	25	-	± 15	-	kV	
	IEC1000-4-2 Contact Discharge	25	-	± 8	-	kV	
	IEC1000-4-2 Air Gap Discharge	25	-	± 15	-	kV	
All Other Pins	Human Body Model	25	-	± 3	-	kV	

NOTE:

- Transmitter skew is measured at the transmitter zero crossing points.

Detailed Description

The ISL83220E operates from a single +3V to +5.5V supply, guarantees a 250kbps minimum data rate, requires only four small external 0.1 μF capacitors, features low power consumption, and meets all EIA RS-232C and V.28 specifications. The circuit is divided into three sections: The charge pump, the transmitter, and the receiver.

Charge-Pump

Intersil's new 3.3V family utilizes regulated on-chip dual charge pumps as voltage doublers, and voltage inverters to generate $\pm 5.5V$ transmitter supplies from a V_{CC} supply as low as 3.0V. This allows these devices to maintain RS-232 compliant output levels over the $\pm 10\%$ tolerance range of 3.3V powered systems. The efficient on-chip power supplies require only four small, external 0.1 μF capacitors for the voltage doubler and inverter functions, even at $V_{CC} = 3.3V$. The charge pumps operate discontinuously (i.e., they turn off as soon as the V+ and V- supplies are pumped up to the nominal values), resulting in significant power savings.

Transmitters

The transmitters are proprietary, low dropout, inverting drivers that translate TTL/CMOS inputs to EIA/TIA-232 output levels. Coupled with the on-chip $\pm 5.5V$ supplies, these transmitters deliver true RS-232 levels over a wide range of single supply system voltages.

The transmitter output disables and assumes a high impedance state when the device enters the powerdown mode (see Table 2). This output may be driven to $\pm 12V$ when disabled.

All devices guarantee a 250kbps data rate for full load conditions ($3k\Omega$ and $1000pF$), $V_{CC} \geq 3.0V$. Under more typical conditions of $V_{CC} \geq 3.3V$, $R_L = 3k\Omega$, and $C_L = 250pF$, the ISL83220E easily operates at 900kbps.

Transmitter inputs float if left unconnected, and may cause I_{CC} increases.

Power Supply Decoupling

In most circumstances a 0.1µF bypass capacitor is adequate. In applications that are particularly sensitive to power supply noise, decouple V_{CC} to ground with a capacitor of the same value as the charge-pump capacitor C₁. Connect the bypass capacitor as close as possible to the IC.

Transmitter Output when Exiting Powerdown

Figure 3 shows the response of the transmitter output when exiting powerdown mode. As it activates, the transmitter output properly goes to RS-232 levels, with no glitching, ringing, nor undesirable transients. The transmitter is loaded with 3kΩ in parallel with 2500pF. Note that the transmitter enables only when the magnitude of the supplies exceed approximately 3V.

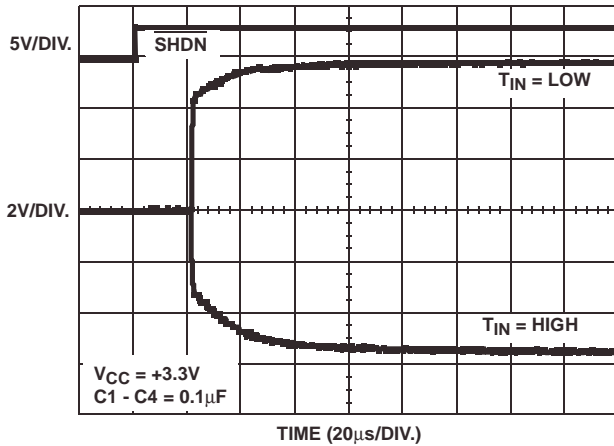

FIGURE 3. TRANSMITTER OUTPUT WHEN EXITING POWERDOWN

High Data Rates

The ISL83220E maintains the RS-232 ±5V minimum transmitter output voltages even at high data rates. Figure 4 details a transmitter loopback test circuit, and Figure 5 illustrates the loopback test result at 120kbps. For this test, the transmitter is driving an RS-232 load in parallel with 1000pF, at 120kbps. Figure 6 shows the loopback results for the transmitter driving 1000pF and an RS-232 load at 250kbps.

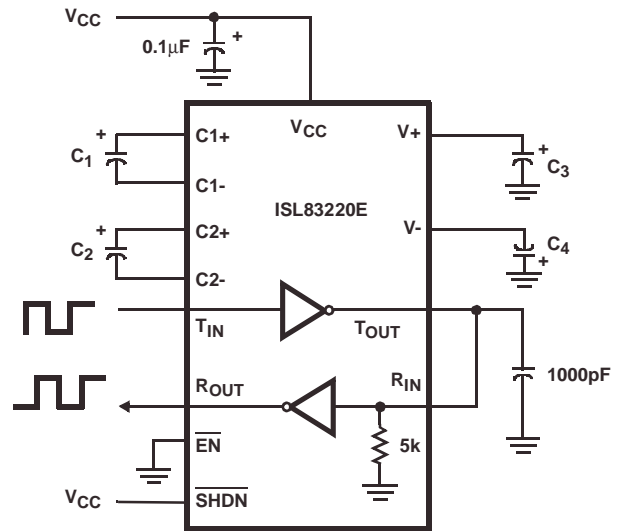

FIGURE 4. TRANSMITTER LOOPBACK TEST CIRCUIT

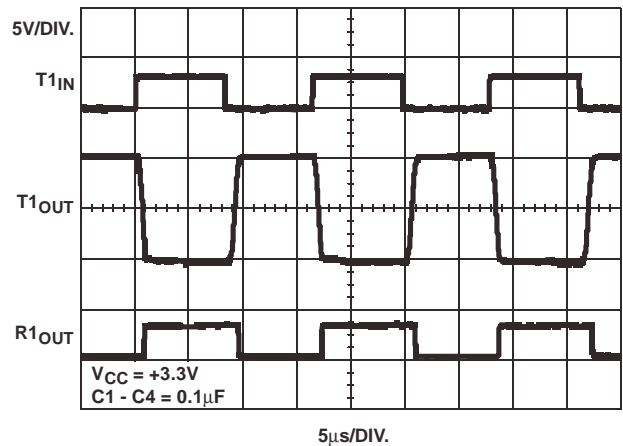

FIGURE 5. LOOPBACK TEST AT 120kbps

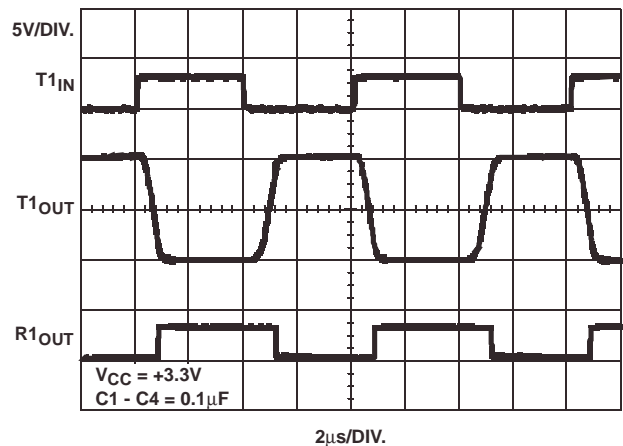

FIGURE 6. LOOPBACK TEST AT 250kbps

Interconnection with 3V and 5V Logic

The ISL83220E directly interfaces with 5V CMOS and TTL logic families. Nevertheless, with the ISL83220E at 3.3V, and the logic supply at 5V, AC, HC, and CD4000 outputs can drive ISL83220E inputs, but ISL83220E outputs do not reach the minimum V_{IH} for these logic families. See Table 3 for more information.

TABLE 3. LOGIC FAMILY COMPATIBILITY WITH VARIOUS SUPPLY VOLTAGES

SYSTEM POWER-SUPPLY VOLTAGE (V)	V _{CC} SUPPLY VOLTAGE (V)	COMPATIBILITY
3.3	3.3	Compatible with all CMOS families.
5	5	Compatible with all TTL and CMOS logic families.
5	3.3	Compatible with ACT and HCT CMOS, and with TTL. ISL83220E outputs are incompatible with AC, HC, and CD4000 CMOS inputs.

±15kV ESD Protection

All pins on ISL8XXX devices include ESD protection structures, but the ISL8XXXE family incorporates advanced structures which allow the RS-232 pins (transmitter outputs and receiver inputs) to survive ESD events up to ±15kV. The RS-232 pins are particularly vulnerable to ESD damage because they typically connect to an exposed port on the exterior of the finished product. Simply touching the port pins, or connecting a cable, can cause an ESD event that might destroy unprotected ICs. These new ESD structures protect the device whether or not it is powered up, protect without allowing any latchup mechanism to activate, and don't interfere with RS-232 signals as large as ±25V.

Human Body Model (HBM) Testing

As the name implies, this test method emulates the ESD event delivered to an IC during human handling. The tester delivers the charge through a 1.5kΩ current limiting resistor, making the test less severe than the IEC-1000 test which utilizes a 330Ω limiting resistor. The HBM method determines an ICs ability to withstand the ESD transients typically present during handling and manufacturing. Due to the random nature of these events, each pin is tested with respect to all other pins. The RS-232 pins on "E" family devices can withstand HBM ESD events to ±15kV.

IEC1000-4-2 Testing

The IEC 1000 test method applies to finished equipment, rather than to an individual IC. Therefore, the pins most likely to suffer an ESD event are those that are exposed to the outside world (the RS-232 pins in this case), and the IC is tested in its typical application configuration (power applied) rather than testing each pin-to-pin combination. The lower

current limiting resistor coupled with the larger charge storage capacitor yields a test that is much more severe than the HBM test. The extra ESD protection built into this device's RS-232 pins allows the design of equipment meeting level 4 criteria without the need for additional board level protection on the RS-232 port.

AIR-GAP DISCHARGE TEST METHOD

For this test method, a charged probe tip moves toward the IC pin until the voltage arcs to it. The current waveform delivered to the IC pin depends on approach speed, humidity, temperature, etc., so it is difficult to obtain repeatable results. The "E" device RS-232 pins withstand ±15kV air-gap discharges.

CONTACT DISCHARGE TEST METHOD

During the contact discharge test, the probe contacts the tested pin before the probe tip is energized, thereby eliminating the variables associated with the air-gap discharge. The result is a more repeatable and predictable test, but equipment limits prevent testing devices at voltages higher than ±8kV. All "E" family devices survive ±8kV contact discharges on the RS-232 pins.

Typical Performance Curves $V_{CC} = 3.3V, T_A = 25^{\circ}C$

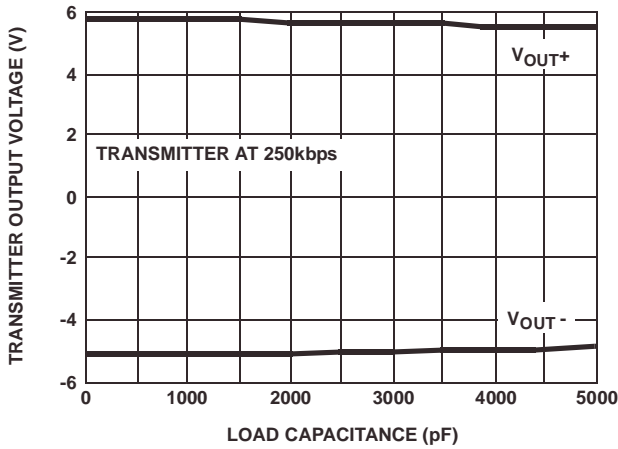

FIGURE 7. TRANSMITTER OUTPUT VOLTAGE vs LOAD CAPACITANCE

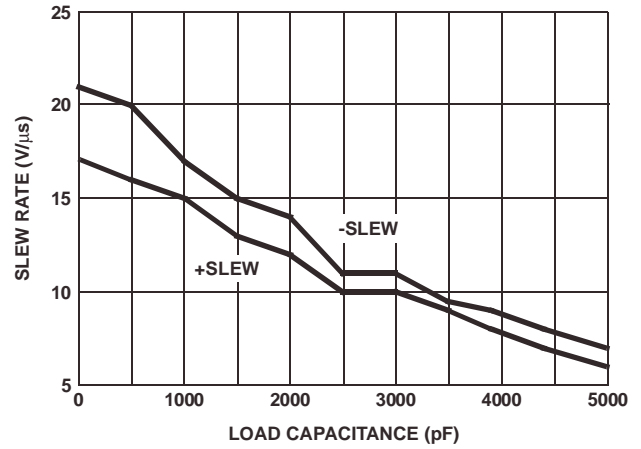

FIGURE 8. SLEW RATE vs LOAD CAPACITANCE

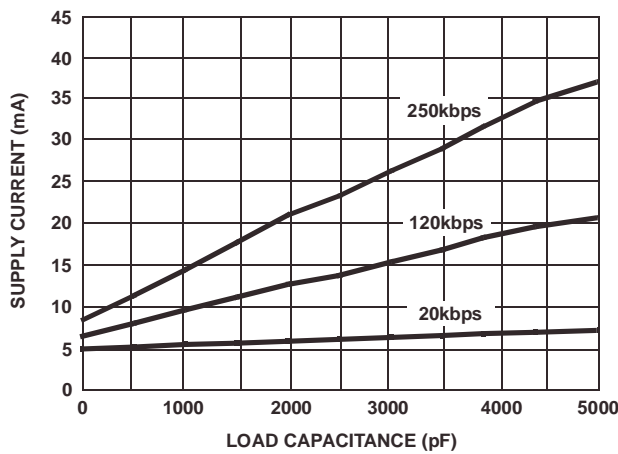

FIGURE 9. SUPPLY CURRENT vs LOAD CAPACITANCE WHEN TRANSMITTING DATA

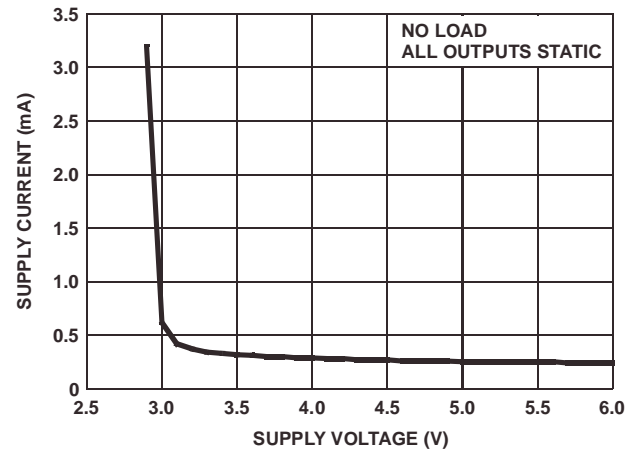

FIGURE 10. SUPPLY CURRENT vs SUPPLY VOLTAGE

Die Characteristics

DIE DIMENSIONS:

100 mils x 100 mils (2540 μ m x 2540 μ m)

METALLIZATION:

Type: Metal 1: AlSi(1%)
 Thickness: Metal 1: 8k \AA
 Type: Metal 2: AlSi(1%)
 Thickness: Metal 2: 10k \AA

SUBSTRATE POTENTIAL (POWERED UP):

GND

PASSIVATION:

Type: Silox
 Thickness: 13k \AA

TRANSISTOR COUNT:

286

PROCESS:

Si Gate CMOS

Small Outline Plastic Packages (SSOP)

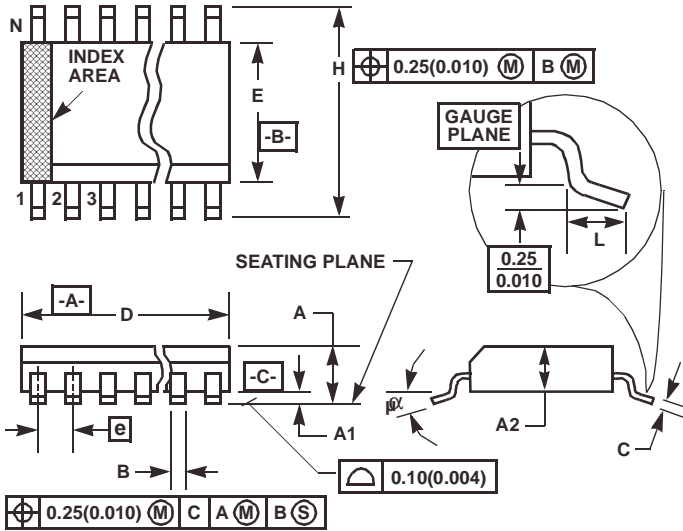

M16.209 (JEDEC MO-150-AC ISSUE B)
16 LEAD SHRINK SMALL OUTLINE PLASTIC PACKAGE

SYMBOL	INCHES		MILLIMETERS		NOTES
	MIN	MAX	MIN	MAX	
A	-	0.078	-	2.00	-
A1	0.002	-	0.05	-	-
A2	0.065	0.072	1.65	1.85	-
B	0.009	0.014	0.22	0.38	9
C	0.004	0.009	0.09	0.25	-
D	0.233	0.255	5.90	6.50	3
E	0.197	0.220	5.00	5.60	4
e	0.026 BSC		0.65 BSC		-
H	0.292	0.322	7.40	8.20	-
L	0.022	0.037	0.55	0.95	6
N	16		16		7
α	0°	8°	0°	8°	-

NOTES:

1. Symbols are defined in the "MO Series Symbol List" in Section 2.2 of Publication Number 95.
2. Dimensioning and tolerancing per ANSI Y14.5M-1982.
3. Dimension "D" does not include mold flash, protrusions or gate burrs. Mold flash, protrusion and gate burrs shall not exceed 0.20mm (0.0078 inch) per side.
4. Dimension "E" does not include interlead flash or protrusions. Interlead flash and protrusions shall not exceed 0.20mm (0.0078 inch) per side.
5. The chamfer on the body is optional. If it is not present, a visual index feature must be located within the crosshatched area.
6. "L" is the length of terminal for soldering to a substrate.
7. "N" is the number of terminal positions.
8. Terminal numbers are shown for reference only.
9. Dimension "B" does not include dambar protrusion. Allowable dambar protrusion shall be 0.13mm (0.005 inch) total in excess of "B" dimension at maximum material condition.
10. Controlling dimension: MILLIMETER. Converted inch dimensions are not necessarily exact.

Rev. 2 3/95

Small Outline Plastic Packages (SOIC)

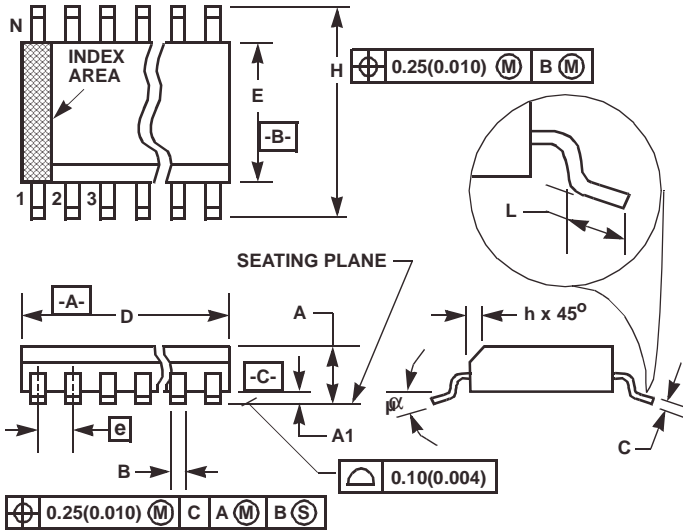

**M16.3 (JEDEC MS-013-AA ISSUE C)
16 LEAD WIDE BODY SMALL OUTLINE PLASTIC PACKAGE**

SYMBOL	INCHES		MILLIMETERS		NOTES
	MIN	MAX	MIN	MAX	
A	0.0926	0.1043	2.35	2.65	-
A1	0.0040	0.0118	0.10	0.30	-
B	0.013	0.0200	0.33	0.51	9
C	0.0091	0.0125	0.23	0.32	-
D	0.3977	0.4133	10.10	10.50	3
E	0.2914	0.2992	7.40	7.60	4
e	0.050 BSC		1.27 BSC		-
H	0.394	0.419	10.00	10.65	-
h	0.010	0.029	0.25	0.75	5
L	0.016	0.050	0.40	1.27	6
N	16		16		7
α	0°	8°	0°	8°	-

NOTES:

1. Symbols are defined in the "MO Series Symbol List" in Section 2.2 of Publication Number 95.
2. Dimensioning and tolerancing per ANSI Y14.5M-1982.
3. Dimension "D" does not include mold flash, protrusions or gate burrs. Mold flash, protrusion and gate burrs shall not exceed 0.15mm (0.006 inch) per side.
4. Dimension "E" does not include interlead flash or protrusions. Interlead flash and protrusions shall not exceed 0.25mm (0.010 inch) per side.
5. The chamfer on the body is optional. If it is not present, a visual index feature must be located within the crosshatched area.
6. "L" is the length of terminal for soldering to a substrate.
7. "N" is the number of terminal positions.
8. Terminal numbers are shown for reference only.
9. The lead width "B", as measured 0.36mm (0.014 inch) or greater above the seating plane, shall not exceed a maximum value of 0.61mm (0.024 inch)
10. Controlling dimension: MILLIMETER. Converted inch dimensions are not necessarily exact.

Rev. 0 12/93

All Intersil products are manufactured, assembled and tested utilizing ISO9000 quality systems.
Intersil Corporation's quality certifications can be viewed at www.intersil.com/design/quality

Intersil products are sold by description only. Intersil Corporation reserves the right to make changes in circuit design and/or specifications at any time without notice. Accordingly, the reader is cautioned to verify that data sheets are current before placing orders. Information furnished by Intersil is believed to be accurate and reliable. However, no responsibility is assumed by Intersil or its subsidiaries for its use; nor for any infringements of patents or other rights of third parties which may result from its use. No license is granted by implication or otherwise under any patent or patent rights of Intersil or its subsidiaries.

For information regarding Intersil Corporation and its products, see www.intersil.com

Sales Office Headquarters

NORTH AMERICA

Intersil Corporation
7585 Irvine Center Drive
Suite 100
Irvine, CA 92618
TEL: (949) 341-7000
FAX: (949) 341-7123

Intersil Corporation
2401 Palm Bay Rd.
Palm Bay, FL 32905
TEL: (321) 724-7000
FAX: (321) 724-7946

EUROPE

Intersil Europe Sarl
Ave. C - F Ramuz 43
CH-1009 Pully
Switzerland
TEL: +41 21 7293637
FAX: +41 21 7293684

ASIA

Intersil Corporation
Unit 1804 18/F Guangdong Water Building
83 Austin Road
TST, Kowloon Hong Kong
TEL: +852 2723 6339
FAX: +852 2730 1433