

±15kV ESD Protected, 10nA Supply-Current, +3V to +5.5V, 250kbps, RS-232 Transmitters/Receivers

The Intersil ISL83239E contains 3.0V to 5.5V powered RS-232 transmitters/receivers which meet EIA/TIA-232 and V.28/V.24 specifications, even at $V_{CC} = 3.0V$. Additionally, it provides ±15kV ESD protection (IEC 1000-4-2 Air Gap and Human Body Model) on transmitter outputs and receiver inputs (RS-232 pins). Targeted applications are cell phones, PDAs, Palmtops, and data cables where the low operational, and even lower standby, power consumption is critical. Efficient on-chip charge pumps, coupled with the manual powerdown function, reduce the standby supply current to a 10nA trickle. Small footprint packaging, and the use of small, low value capacitors ensure board space savings as well. Data rates greater than 250kbps are guaranteed at worst case load conditions.

The ISL83239E is a 5 driver, 3 receiver device that also includes a noninverting always-active receiver for “wake-up” capability.

Table 1 summarizes the features of the device represented by this data sheet, while Application Note AN9863 summarizes the features of each device comprising the ICL32XX 3V family.

Features

- ESD Protection For RS-232 I/O Pins to ±15kV (IEC1000)
- Drop In Replacement for SP3239E
- Meets EIA/TIA-232 and V.28/V.24 Specifications at 3V
- RS-232 Compatible Outputs at 2.7V
- Latch-Up Free
- On-Chip Voltage Converters Require Only Four External Capacitors
- Manual Powerdown Feature
- Flow Through Pinout
- Rx and Tx Hysteresis For Improved Noise Immunity
- Guaranteed Minimum Data Rate 250kbps
- Guaranteed Minimum Slew Rate 6V/μs
- Wide Power Supply Range Single +3V to +5.5V
- Low Supply Current in Powerdown State 10nA

Applications

- Any System Requiring RS-232 Communication Ports
 - Battery Powered, Hand-Held, and Portable Equipment
 - Laptop Computers, Notebooks, Palmtops
 - Modems, Printers and other Peripherals
 - PDA Data Cradles and Cables
 - Cellular/Mobile Phones, Data Cables

Ordering Information

PART NO.	TEMP. RANGE (°C)	PACKAGE	PKG. NO.
ISL83239EIA	-40 to 85	28 Ld SSOP	M28.209
ISL83239EIA-T	-40 to 85	Tape and Reel	M28.209
ISL83239EIV	-40 to 85	28 Ld TSSOP	M28.173
ISL83239EIV-T	-40 to 85	Tape and Reel	M28.173

TABLE 1. SUMMARY OF FEATURES

PART NUMBER	NO. OF Tx.	NO. OF Rx.	NO. OF MONITOR Rx. (ROUTB)	DATA RATE (kbps)	Rx. ENABLE FUNCTION?	READY OUTPUT?	MANUAL POWER-DOWN?	AUTOMATIC POWERDOWN FUNCTION?
ISL83239E	5	3	1	250	NO	NO	YES	NO

Pinout

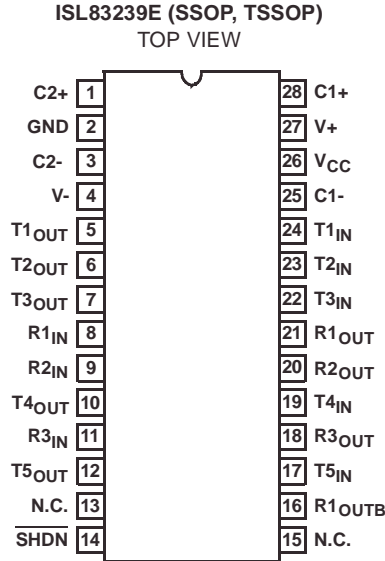

Pin Descriptions

PIN	FUNCTION
V _{CC}	System power supply input (3.0V to 5.5V).
V+	Internally generated positive transmitter supply (+5.5V).
V-	Internally generated negative transmitter supply (-5.5V).
GND	Ground connection.
C1+	External capacitor (voltage doubler) is connected to this lead.
C1-	External capacitor (voltage doubler) is connected to this lead.
C2+	External capacitor (voltage inverter) is connected to this lead.
C2-	External capacitor (voltage inverter) is connected to this lead.
T _{IN}	TTL/CMOS compatible transmitter Inputs.
T _{OUT}	±15kV ESD Protected, RS-232 level (nominally ±5.5V) transmitter outputs.
R _{IN}	±15kV ESD Protected, RS-232 compatible receiver inputs.
R _{OUT}	TTL/CMOS level receiver outputs.
R _{OUTB}	TTL/CMOS level, noninverting, always enabled receiver output.
SHDN	Active low input shuts down transmitters, receivers, and on-board power supply, to place device in low power mode.
N.C.	No internal connection.

Typical Operating Circuit

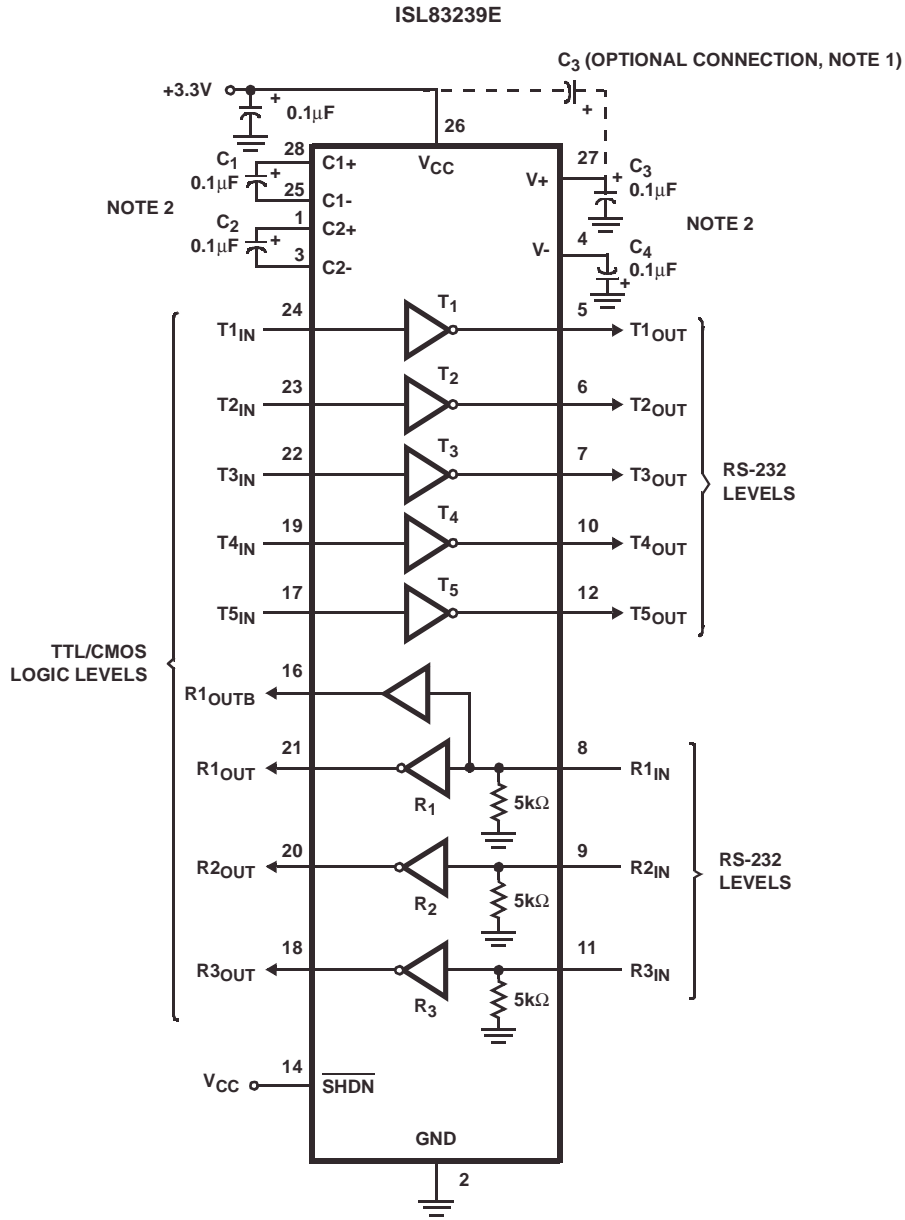

NOTES:

1. THE NEGATIVE TERMINAL OF C₃ CAN BE CONNECTED TO EITHER V_{CC} OR GND.
2. FOR V_{CC} = 3.15V (3.3V -5%), USE C₁ - C₄ = 0.1 μF OR GREATER. FOR V_{CC} = 3.0V (3.3V -10%), USE C₁ - C₄ = 0.22 μF.

Absolute Maximum Ratings

V_{CC} to Ground -0.3V to 6V
 V+ to Ground -0.3V to 7V
 V- to Ground +0.3V to -7V
 V+ to V- 14V
 Input Voltages
 T_{IN}, $\overline{\text{SHDN}}$ -0.3V to 6V
 R_{IN} ±25V
 Output Voltages
 T_{OUT} ±13.2V
 R_{OUT} -0.3V to V_{CC} +0.3V
 Short Circuit Duration
 T_{OUT} Continuous
 ESD Rating See Specification Table

Thermal Information

Thermal Resistance (Typical, Note 3) θ_{JA} (°C/W)
 28 Ld TSSOP Package 75
 28 Ld SSOP Package 100
 Moisture Sensitivity (see Technical Brief TB363)
 All Packages Level 1
 Maximum Junction Temperature (Plastic Package) 150°C
 Maximum Storage Temperature Range -65°C to 150°C
 Maximum Lead Temperature (Soldering 10s) 300°C
 (Lead Tips Only)

Operating Conditions

Temperature Range
 ISL83239EI -40°C to 85°C

CAUTION: Stresses above those listed in "Absolute Maximum Ratings" may cause permanent damage to the device. This is a stress only rating and operation of the device at these or any other conditions above those indicated in the operational sections of this specification is not implied.

NOTE:

- θ_{JA} is measured with the component mounted on a low effective thermal conductivity test board in free air. See Tech Brief TB379 for details.

Electrical Specifications

Test Conditions: V_{CC} = 3.15V to 5.5V, C₁ - C₄ = 0.1µF; V_{CC} = 3V, C₁ - C₄ = 0.22µF, Unless Otherwise Specified. Typical values are at T_A = 25°C

PARAMETER	TEST CONDITIONS	TEMP (°C)	MIN	TYP	MAX	UNITS
DC CHARACTERISTICS						
Supply Current, Powerdown Disabled	All Outputs Unloaded, V _{CC} = 3.15V, $\overline{\text{SHDN}} = V_{CC}$	25	-	0.3	1.0	mA
Supply Current, Powerdown	$\overline{\text{SHDN}} = \text{GND}$	25	-	10	300	nA
LOGIC AND TRANSMITTER INPUTS AND RECEIVER OUTPUTS						
Input Logic Threshold Low	T _{IN} , $\overline{\text{SHDN}}$	Full	-	-	0.8	V
Input Logic Threshold High	T _{IN} , $\overline{\text{SHDN}}$	V _{CC} = 3.3V	Full	2.0	-	V
		V _{CC} = 5.0V	Full	2.4	-	V
Transmitter Input Hysteresis		25	-	0.5	-	V
Input Leakage Current	T _{IN} , $\overline{\text{SHDN}}$	Full	-	±0.01	±1.0	µA
Output Leakage Current	$\overline{\text{SHDN}} = \text{GND}$ (Receivers Disabled)	Full	-	±0.05	±10	µA
Output Voltage Low	I _{OUT} = 1.6mA	Full	-	-	0.4	V
Output Voltage High	I _{OUT} = -1.0mA	Full	V _{CC} - 0.6	V _{CC} - 0.1	-	V
RECEIVER INPUTS						
Input Voltage Range		Full	-25	-	25	V
Input Threshold Low	V _{CC} = 3.3V	25	0.6	1.2	-	V
	V _{CC} = 5.0V	25	0.8	1.5	-	V
Input Threshold High	V _{CC} = 3.3V to 5.0V	25	-	1.6	2.4	V
Input Hysteresis		25	-	0.5	-	V
Input Resistance		25	3	5	7	kΩ
TRANSMITTER OUTPUTS						
Output Voltage Swing	All Transmitter Outputs Loaded with 3kΩ to Ground	Full	±5.0	±5.4	-	V
Output Resistance	V _{CC} = V+ = V- = 0V, Transmitter Output = ±2V	Full	300	10M	-	Ω
Output Short-Circuit Current		Full	-	±35	±60	mA
Output Leakage Current	V _{OUT} = ±12V, V _{CC} = 0V or 3V to 5.5V, $\overline{\text{SHDN}} = \text{GND}$	Full	-	-	±25	µA
TIMING CHARACTERISTICS						

ISL83239E

Electrical Specifications Test Conditions: $V_{CC} = 3.15V$ to $5.5V$, $C_1 - C_4 = 0.1\mu F$; $V_{CC} = 3V$, $C_1 - C_4 = 0.22\mu F$, Unless Otherwise Specified. Typicals are at $T_A = 25^\circ C$ **(Continued)**

PARAMETER	TEST CONDITIONS	TEMP (°C)	MIN	TYP	MAX	UNITS	
Maximum Data Rate	$R_L = 3k\Omega$, $C_L = 1000pF$ One Transmitter Switching	Full	250	700	-	kbps	
Receiver Propagation Delay	Receiver Input to Receiver Output, $C_L = 150pF$	t _{PHL}	25	-	0.15	-	μs
		t _{PLH}	25	-	0.15	-	μs
Receiver Output Enable Time	Normal Operation	25	-	200	-	ns	
Receiver Output Disable Time	Normal Operation	25	-	200	-	ns	
Transmitter Skew	t _{PHL} - t _{PLH}	25	-	100		ns	
Receiver Skew	t _{PHL} - t _{PLH} , $C_L = 150pF$	25	-	50	-	ns	
Transition Region Slew Rate	$V_{CC} = 3.3V$, $R_L = 3k\Omega$ to $7k\Omega$, Measured From $3V$ to $-3V$ or $-3V$ to $3V$	$C_L = 150pF$ to $1000pF$	25	6	17	30	$V/\mu s$
		$C_L = 150pF$ to $2500pF$	25	4	12	30	$V/\mu s$
ESD PERFORMANCE							
RS-232 Pins (T _{OUT} , R _{IN})	Human Body Model	25	-	±15	-	kV	
	IEC1000-4-2 Air Gap Discharge	25	-	±15	-	kV	
	IEC1000-4-2 Contact Discharge	25	-	±8	-	kV	
All Other Pins	Human Body Model	25	-	±2.5	-	kV	

Detailed Description

The ISL83239E operates from a single +3V to +5.5V supply, guarantees a 250kbps minimum data rate, requires only four small external 0.1µF (0.22µF for V_{CC} = 3.0V) capacitors, features low power consumption, and meets all EIA/TIA-232 and V.28 specifications. The circuit is divided into three sections: The charge pump, the transmitters, and the receivers.

Charge-Pump

Intersil's new 3V RS-232 family utilizes regulated on-chip dual charge pumps as voltage doublers, and voltage inverters to generate ±5.5V transmitter supplies from a V_{CC} supply as low as 3.0V. This allows these devices to maintain RS-232 compliant output levels over the ±10% tolerance range of 3.3V powered systems. The efficient on-chip power supplies require only four small, external 0.1µF capacitors for the voltage doubler and inverter functions at V_{CC} = 3.3V. See the "Capacitor Selection" section, and Table 3 for capacitor recommendations for other operating conditions. The charge pumps operate discontinuously (i.e., they turn off as soon as the V+ and V- supplies are pumped up to the nominal values), resulting in significant power savings.

Transmitters

The transmitters are proprietary, low dropout, inverting drivers that translate TTL/CMOS inputs to EIA/TIA-232 output levels. Coupled with the on-chip ±5.5V supplies, these transmitters deliver true RS-232 levels over a wide range of single supply system voltages.

All transmitter outputs disable and assume a high impedance state when the device enters the powerdown mode (see Table 2). These outputs may be driven to ±12V when disabled.

The ISL83239E guarantees a 250Kbps data rate for full load conditions (3kΩ and 250pF), V_{CC} ≥ 3.0V, with one transmitter operating at full speed. Under more typical conditions of V_{CC} ≥ 3.3V, C₁₋₄ = 0.1µF, R_L = 3kΩ, and C_L = 250pF, one transmitter easily operates at 1Mbps.

Transmitter inputs float if left unconnected, and may cause I_{CC} increases. Connect unused inputs to GND for the best performance.

Receivers

The ISL83239E contains standard inverting receivers that tristate when the SHDN control line is driven low.

Additionally, it includes a noninverting (monitor) receiver (denoted by the R_{OUTB} label) that is always active, regardless of the state of any control lines. All the receivers convert RS-232 signals to CMOS output levels and accept inputs up to ±25V while presenting the required 3kΩ to 7kΩ input impedance (see Figure 1) even if the power is off (V_{CC} = 0V). The receivers' Schmitt trigger input stage uses hysteresis to increase noise immunity and decrease errors due to slow input signal transitions.

Monitor receivers remain active even during manual powerdown, making them extremely useful for Ring Indicator monitoring. Standard receivers driving powered down peripherals must be disabled to prevent current flow through the peripheral's protection diodes (see Figures 2 and 3). This renders them useless for wake up functions, but the corresponding monitor receiver can be dedicated to this task as shown in Figure 3.

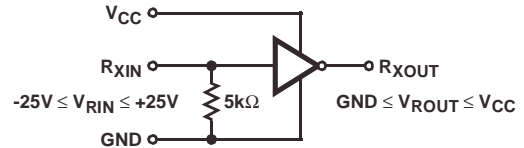

FIGURE 1. INVERTING RECEIVER CONNECTIONS

Powerdown Functionality

This 3V device requires a nominal supply current of 0.3mA during normal operation (not in powerdown mode). This is considerably less than the 5mA to 11mA current required of 5V RS-232 devices. The already low current requirement drops significantly when the device enters powerdown mode. In powerdown, supply current drops to 10nA, because the on-chip charge pump turns off (V+ collapses to V_{CC}, V- collapses to GND), and the transmitter outputs tristate. This micro-power mode makes the ISL83239E ideal for battery powered and portable applications.

Software Controlled (Manual) Powerdown

On the ISL83239E, the powerdown control is via a simple shutdown ($\overline{\text{SHDN}}$) pin. Driving this pin high enables normal operation, while driving it low forces the IC into its powerdown state. Connect $\overline{\text{SHDN}}$ to V_{CC} if the powerdown function isn't needed. Note that all the transmitter and receiver outputs tri-state during shutdown (see Table 2). The time required to exit powerdown, and resume transmission is only 100µs.

TABLE 2. POWERDOWN LOGIC TRUTH TABLE

SHDN INPUT	TRANSMITTER OUTPUTS	RECEIVER OUTPUTS	R _{OUTB} OUTPUT	MODE OF OPERATION
L	High-Z	High-Z	Active	Manual Powerdown
H	Active	Active	Active	Normal Operation

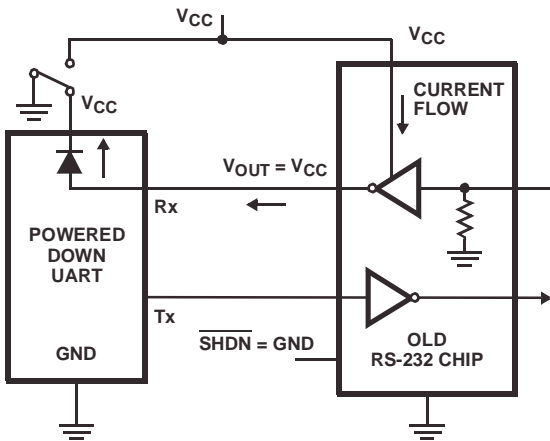

FIGURE 2. POWER DRAIN THROUGH POWERED DOWN PERIPHERAL

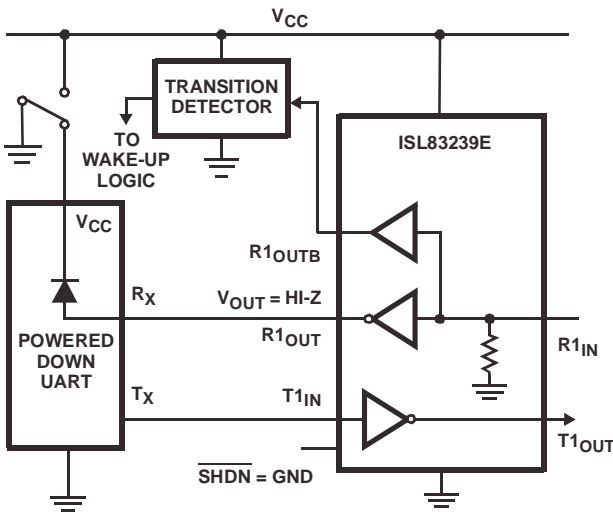

FIGURE 3. DISABLED RECEIVERS PREVENT POWER DRAIN

Capacitor Selection

The charge pumps require 0.1µF capacitors for 3.3V (5% tolerance) operation. For other supply voltages refer to Table 3 for capacitor values. Do not use values smaller than those listed in Table 3. Increasing the capacitor values (by a factor of 2) reduces ripple on the transmitter outputs and slightly reduces power consumption. C₂, C₃, and C₄ can be increased without increasing C₁'s value, however, do not increase C₁ without also increasing C₂, C₃, and C₄ to maintain the proper ratios (C₁ to the other capacitors).

When using minimum required capacitor values, make sure that capacitor values do not degrade excessively with temperature. If in doubt, use capacitors with a larger nominal value. The capacitor's equivalent series resistance (ESR) usually rises at low temperatures and it influences the amount of ripple on V₊ and V₋.

TABLE 3. REQUIRED CAPACITOR VALUES

V _{CC} (V)	C ₁ (µF)	C ₂ , C ₃ , C ₄ (µF)
3.0 to 3.6 (3.3V ±10%)	0.22	0.22
3.15 to 3.6 (3.3V ±5%)	0.1	0.1
4.5 to 5.5	0.047	0.33
3.0 to 5.5	0.22	1.0

Power Supply Decoupling

In most circumstances a 0.1µF bypass capacitor is adequate. In applications that are particularly sensitive to power supply noise, decouple V_{CC} to ground with a capacitor of the same value as the charge-pump capacitor C₁. Connect the bypass capacitor as close as possible to the IC.

Operation down to 2.7V

ISL83239E transmitter outputs meet RS-562 levels (±3.7V) with V_{CC} as low as 2.7V. RS-562 levels typically ensure interoperability with RS-232 devices.

Transmitter Outputs when Exiting Powerdown

Figure 4 shows the response of two transmitter outputs when exiting powerdown mode. As they activate, the two transmitter outputs properly go to opposite RS-232 levels, with no glitching, ringing, nor undesirable transients. Each transmitter is loaded with 3kΩ in parallel with 2500pF. Note that the transmitters enable only when the magnitude of the supplies exceed approximately 3V.

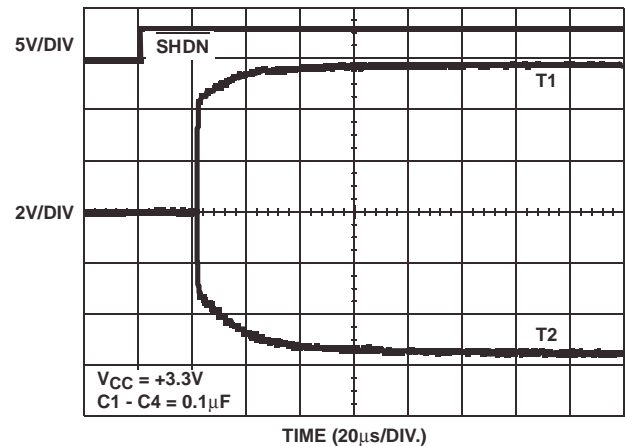

FIGURE 4. TRANSMITTER OUTPUTS WHEN EXITING POWERDOWN

High Data Rates

The ISL83239E maintains the RS-232 ±5V minimum transmitter output voltages even at high data rates. Figure 5 details a transmitter loopback test circuit, and Figure 6 illustrates the loopback test result at 120kbps. For this test,

all transmitters were simultaneously driving RS-232 loads in parallel with 1000pF, at 120kbps. Figure 7 shows the loopback results for a single transmitter driving 1000pF and an RS-232 load at 250kbps. The static transmitters were also loaded with an RS-232 receiver.

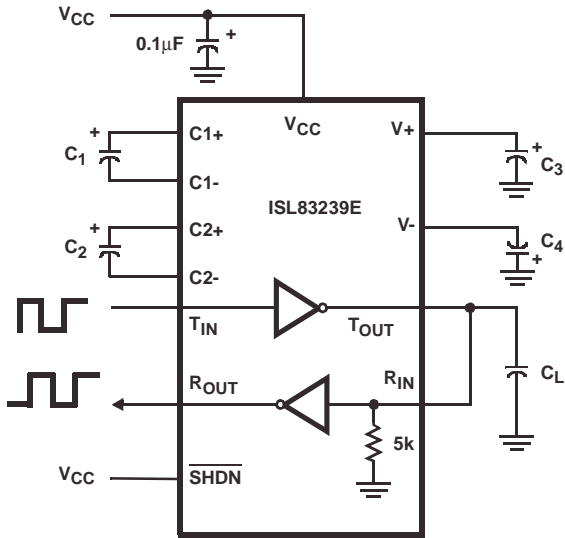

FIGURE 5. TRANSMITTER LOOPBACK TEST CIRCUIT

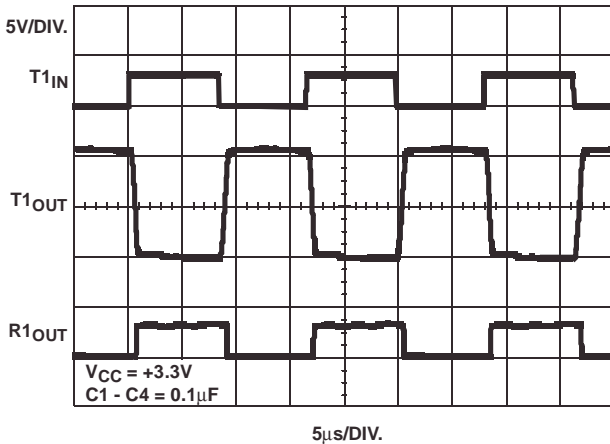

FIGURE 6. LOOPBACK TEST AT 120kbps

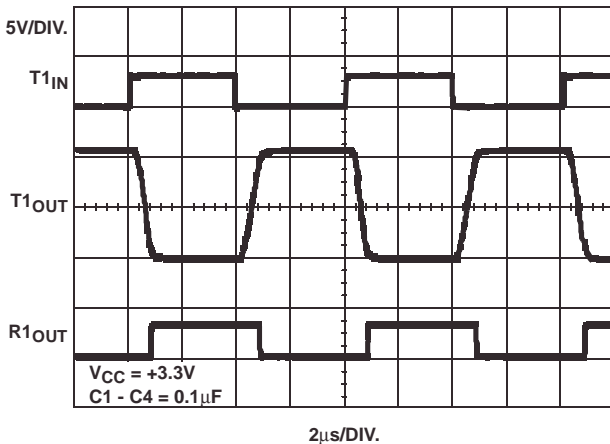

FIGURE 7. LOOPBACK TEST AT 250kbps

Interconnection with 3V and 5V Logic

The ISL83239E directly interfaces with 5V CMOS and TTL logic families. Nevertheless, with the device at 3.3V, and the logic supply at 5V, AC, HC, and CD4000 outputs can drive ISL83239E inputs, but ISL83239E outputs do not reach the minimum V_{IH} for these logic families. See Table 4 for more information.

TABLE 4. LOGIC FAMILY COMPATIBILITY WITH VARIOUS SUPPLY VOLTAGES

SYSTEM POWER-SUPPLY VOLTAGE (V)	V _{CC} SUPPLY VOLTAGE (V)	COMPATIBILITY
3.3	3.3	Compatible with all CMOS families.
5	5	Compatible with all TTL and CMOS logic families.
5	3.3	Compatible with ACT and HCT CMOS, and with TTL. ISL83239E outputs are incompatible with AC, HC, and CD4000 CMOS inputs.

±15kV ESD Protection

All pins on ISL832XX devices include ESD protection structures, but the ISL83239E fsincorporates advanced structures which allow the RS-232 pins (transmitter outputs and receiver inputs) to survive ESD events up to ±15kV. The RS-232 pins are particularly vulnerable to ESD damage because they typically connect to an exposed port on the exterior of the finished product. Simply touching the port pins, or connecting a cable, can cause an ESD event that might destroy unprotected ICs. These new ESD structures protect the device whether or not it is powered up, protect without allowing any latchup mechanism to activate, and don't interfere with RS-232 signals as large as ±25V.

Human Body Model (HBM) Testing

As the name implies, this test method emulates the ESD event delivered to an IC during human handling. The tester delivers the charge through a 1.5kΩ current limiting resistor, making the test less severe than the IEC-1000 test which utilizes a 330Ω limiting resistor. The HBM method determines an ICs ability to withstand the ESD transients typically present during handling and manufacturing. Due to the random nature of these events, each pin is tested with respect to all other pins. The RS-232 pins on "E" family devices can withstand HBM ESD events to ±15kV.

IEC1000-4-2 Testing

The IEC 1000 test method applies to finished equipment, rather than to an individual IC. Therefore, the pins most likely to suffer an ESD event are those that are exposed to the outside world (the RS-232 pins in this case), and the IC is tested in its typical application configuration (power applied) rather than testing each pin-to-pin combination. The lower

current limiting resistor coupled with the larger charge storage capacitor yields a test that is much more severe than the HBM test. The extra ESD protection built into this device's RS-232 pins allows the design of equipment meeting level 4 criteria without the need for additional board level protection on the RS-232 port.

AIR-GAP DISCHARGE TEST METHOD

For this test method, a charged probe tip moves toward the IC pin until the voltage arcs to it. The current waveform delivered to the IC pin depends on approach speed, humidity, temperature, etc., so it is difficult to obtain

repeatable results. The "E" device RS-232 pins withstand ±15kV air-gap discharges.

CONTACT DISCHARGE TEST METHOD

During the contact discharge test, the probe contacts the tested pin before the probe tip is energized, thereby eliminating the variables associated with the air-gap discharge. The result is a more repeatable and predictable test, but equipment limits prevent testing devices at voltages higher than ±8kV. All "E" family devices survive ±8kV contact discharges on the RS-232 pins.

Typical Performance Curves $V_{CC} = 3.3V, T_A = 25^{\circ}C$

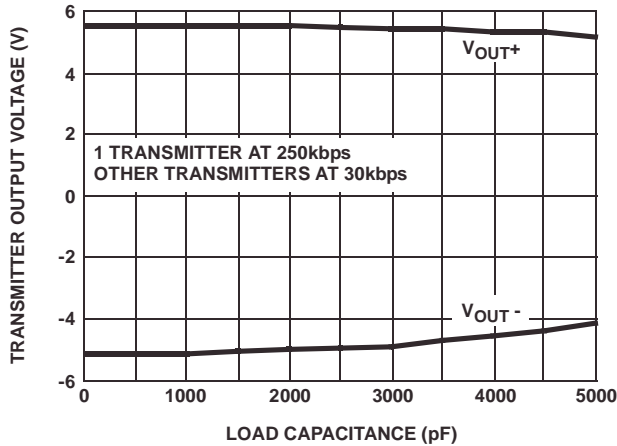

FIGURE 8. TRANSMITTER OUTPUT VOLTAGE vs LOAD CAPACITANCE

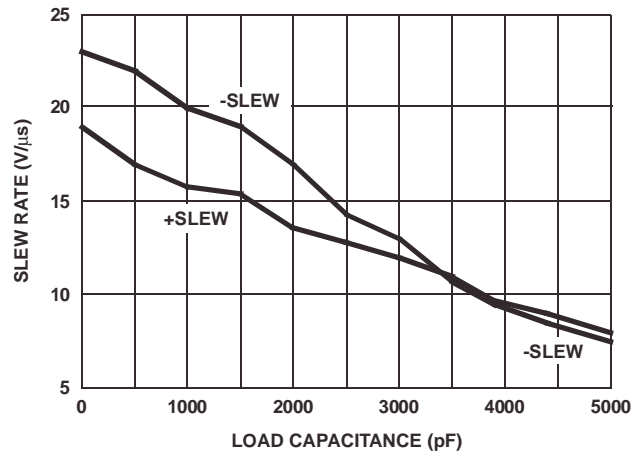

FIGURE 9. SLEW RATE vs LOAD CAPACITANCE

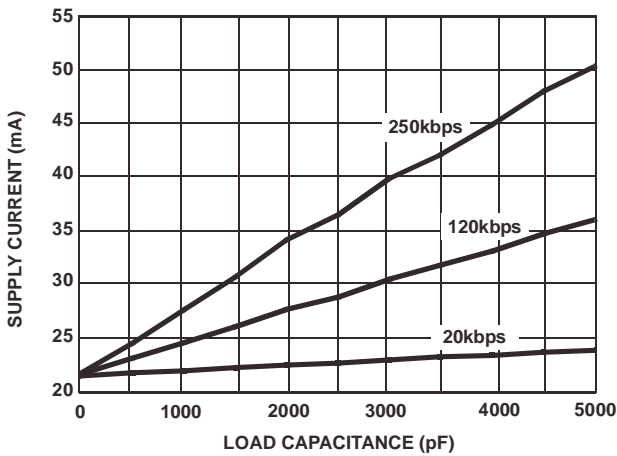

FIGURE 10. SUPPLY CURRENT vs LOAD CAPACITANCE WHEN TRANSMITTING DATA

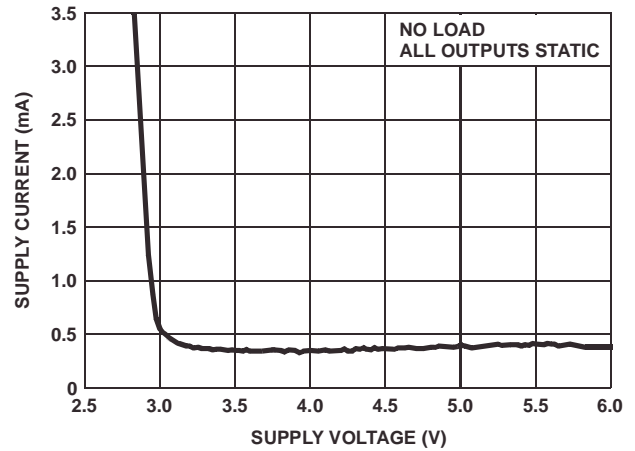

FIGURE 11. SUPPLY CURRENT vs SUPPLY VOLTAGE

Die Characteristics

DIE DIMENSIONS:

106 mils x 128 mils (2700 μ m x 3250 μ m)

METALLIZATION:

Type: Metal 1: AlSi(1%)
Thickness: Metal 1: 8k \AA
Type: Metal 2: AlSi (1%)
Thickness: Metal 2: 10k \AA

SUBSTRATE POTENTIAL (POWERED UP):

GND

PASSIVATION:

Type: Silox
Thickness: 13k \AA

TRANSISTOR COUNT:

609

PROCES

Si Gate CMOS

Shrink Small Outline Plastic Packages (SSOP)

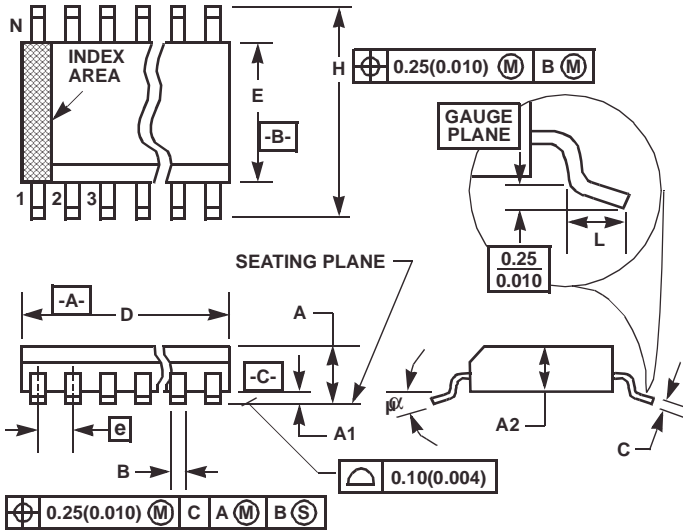

M28.209 (JEDEC MO-150-AH ISSUE B)
28 LEAD SHRINK SMALL OUTLINE PLASTIC PACKAGE

SYMBOL	INCHES		MILLIMETERS		NOTES
	MIN	MAX	MIN	MAX	
A	-	0.078	-	2.00	-
A1	0.002	-	0.05	-	-
A2	0.065	0.072	1.65	1.85	-
B	0.009	0.014	0.22	0.38	9
C	0.004	0.009	0.09	0.25	-
D	0.390	0.413	9.90	10.50	3
E	0.197	0.220	5.00	5.60	4
e	0.026 BSC		0.65 BSC		-
H	0.292	0.322	7.40	8.20	-
L	0.022	0.037	0.55	0.95	6
N	28		28		7
α	0°	8°	0°	8°	-

Rev. 1 3/95

NOTES:

- Symbols are defined in the "MO Series Symbol List" in Section 2.2 of Publication Number 95.
- Dimensioning and tolerancing per ANSI Y14.5M-1982.
- Dimension "D" does not include mold flash, protrusions or gate burrs. Mold flash, protrusion and gate burrs shall not exceed 0.20mm (0.0078 inch) per side.
- Dimension "E" does not include interlead flash or protrusions. Interlead flash and protrusions shall not exceed 0.20mm (0.0078 inch) per side.
- The chamfer on the body is optional. If it is not present, a visual index feature must be located within the crosshatched area.
- "L" is the length of terminal for soldering to a substrate.
- "N" is the number of terminal positions.
- Terminal numbers are shown for reference only.
- Dimension "B" does not include dambar protrusion. Allowable dambar protrusion shall be 0.13mm (0.005 inch) total in excess of "B" dimension at maximum material condition.
- Controlling dimension: MILLIMETER. Converted inch dimensions are not necessarily exact.

Thin Shrink Small Outline Plastic Packages (TSSOP)

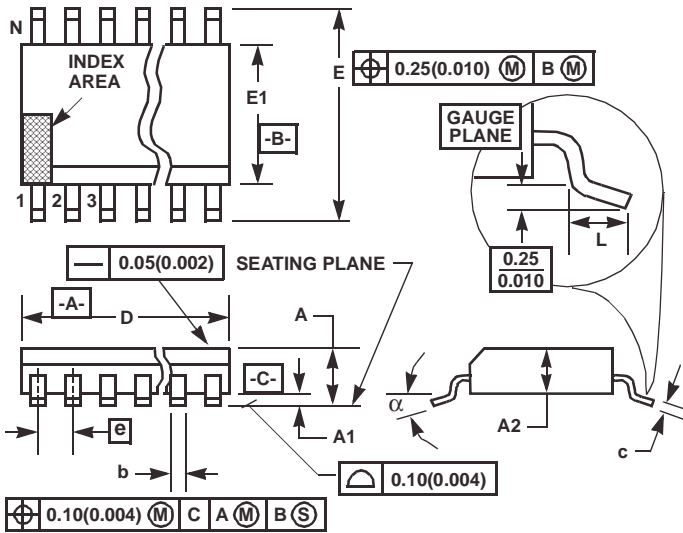

M28.173
28 LEAD THIN SHRINK SMALL OUTLINE PLASTIC PACKAGE

SYMBOL	INCHES		MILLIMETERS		NOTES
	MIN	MAX	MIN	MAX	
A	-	0.047	-	1.20	-
A1	0.002	0.006	0.05	0.15	-
A2	0.031	0.051	0.80	1.05	-
b	0.0075	0.0118	0.19	0.30	9
c	0.0035	0.0079	0.09	0.20	-
D	0.378	0.386	9.60	9.80	3
E1	0.169	0.177	4.30	4.50	4
e	0.026 BSC		0.65 BSC		-
E	0.246	0.256	6.25	6.50	-
L	0.0177	0.0295	0.45	0.75	6
N	28		28		7
α	0°	8°	0°	8°	-

NOTES:

14. These package dimensions are within allowable dimensions of JEDEC MO-153-AE, Issue E.
15. Dimensioning and tolerancing per ANSI Y14.5M-1982.
16. Dimension "D" does not include mold flash, protrusions or gate burrs. Mold flash, protrusion and gate burrs shall not exceed 0.15mm (0.006 inch) per side.
17. Dimension "E1" does not include interlead flash or protrusions. Interlead flash and protrusions shall not exceed 0.15mm (0.006 inch) per side.
18. The chamfer on the body is optional. If it is not present, a visual index feature must be located within the crosshatched area.
19. "L" is the length of terminal for soldering to a substrate.
20. "N" is the number of terminal positions.
21. Terminal numbers are shown for reference only.
22. Dimension "b" does not include dambar protrusion. Allowable dambar protrusion shall be 0.08mm (0.003 inch) total in excess of "b" dimension at maximum material condition. Minimum space between protrusion and adjacent lead is 0.07mm (0.0027 inch).
23. Controlling dimension: MILLIMETER. Converted inch dimensions are not necessarily exact. (Angles in degrees)

Rev. 0 6/98

All Intersil products are manufactured, assembled and tested utilizing ISO9000 quality systems. Intersil Corporation's quality certifications can be viewed at www.intersil.com/design/quality

Intersil products are sold by description only. Intersil Corporation reserves the right to make changes in circuit design and/or specifications at any time without notice. Accordingly, the reader is cautioned to verify that data sheets are current before placing orders. Information furnished by Intersil is believed to be accurate and reliable. However, no responsibility is assumed by Intersil or its subsidiaries for its use; nor for any infringements of patents or other rights of third parties which may result from its use. No license is granted by implication or otherwise under any patent or patent rights of Intersil or its subsidiaries.

For information regarding Intersil Corporation and its products, see www.intersil.com

Sales Office Headquarters

NORTH AMERICA
 Intersil Corporation
 7585 Irvine Center Drive
 Suite 100
 Irvine, CA 92618
 TEL: (949) 341-7000
 FAX: (949) 341-7123

Intersil Corporation
 2401 Palm Bay Rd.
 Palm Bay, FL 32905
 TEL: (321) 724-7000
 FAX: (321) 724-7946

EUROPE
 Intersil Europe Sarl
 Ave. C - F Ramuz 43
 CH-1009 Pully
 Switzerland
 TEL: +41 21 7293637
 FAX: +41 21 7293684

ASIA
 Intersil Corporation
 Unit 1804 18/F Guangdong Water Building
 83 Austin Road
 TST, Kowloon Hong Kong
 TEL: +852 2723 6339
 FAX: +852 2730 1433