

## Ultra Low ON-Resistance, Low Voltage, Single Supply, SPST Analog Switches

The Intersil ISL84715 and ISL84716 devices are low ON-resistance, low voltage, bidirectional, single pole/single throw (SPST) analog switches designed to operate from a single +1.65V to +3.6V supply. Targeted applications include battery powered equipment that benefit from low  $R_{ON}$  resistance, excellent  $R_{ON}$  flatness, and fast switching speeds ( $t_{ON} = 9ns$ ,  $t_{OFF} = 5ns$ ). The digital logic input is 1.8V CMOS compatible when using a single +3V supply.

Cell phones, for example, often face ASIC functionality limitations. The number of analog input or GPIO pins may be limited and digital geometries are not well suited to analog switch performance. This family of parts may be used to switch in additional functionality while reducing ASIC design risk. The ISL8471X are offered in a 5 lead SC70 package, alleviating board space limitations.

The ISL84715 has one normally open (NO) switch and ISL84716 has one normally closed (NC) switch.

**TABLE 1. FEATURES AT A GLANCE**

	<b>ISL84715</b>	<b>ISL84716</b>
<b>Number of Switches</b>	1	1
<b>SW</b>	NO	NC
<b>1.8V <math>R_{ON}</math></b>	0.45 $\Omega$	0.45 $\Omega$
<b>1.8V <math>t_{ON}/t_{OFF}</math></b>	17ns/7ns	17ns/7ns
<b>3V <math>R_{ON}</math></b>	0.24 $\Omega$	0.24 $\Omega$
<b>3V <math>t_{ON}/t_{OFF}</math></b>	8ns/4ns	8ns/4ns
<b>Package</b>	5 Ld SC70	

## Features

- Pb-Free Available
- Drop in replacement for the MAX4715 and MAX4716
- ON resistance ( $R_{ON}$ )
  - $V_{CC} = +2.7V$  . . . . . 0.26 $\Omega$
  - $V_{CC} = +1.8V$  . . . . . 0.45 $\Omega$
- $R_{ON}$  flatness (+2.7V Supply) . . . . . 0.038 $\Omega$
- Single supply operation . . . . . +1.65V to +3.6V
- Fast switching action (+2.7V Supply)
  - $t_{ON}$  . . . . . 9ns
  - $t_{OFF}$  . . . . . 5ns
- ESD HBM rating . . . . . >4kV
- 1.8V, CMOS logic compatible (+3V supply)
- Available in 5 lead SC70 packaging

## Applications

- Battery powered, handheld, and portable equipment
  - Cellular/mobile phones
  - Pagers
  - Laptops, notebooks, palmtops
- Portable Test and Measurement
- Medical Equipment
- Audio and video switching

## Related Literature

- Technical Brief TB363 "Guidelines for Handling and Processing Moisture Sensitive Surface Mount Devices (SMDs)"

**Pinouts** (Note 1)

**ISL84715 (SC70)**  
TOP VIEW

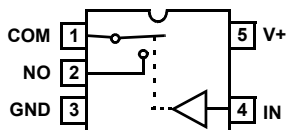

**ISL84716 (SC70)**  
TOP VIEW

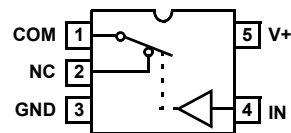

NOTE:

1. Switches Shown for Logic "0" Input.

**Truth Table**

LOGIC	ISL84715	ISL84716
0	Off	On
1	On	Off

NOTE: Logic "0"  $\leq 0.5V$ . Logic "1"  $\geq 1.4V$  with a 3V supply.

**Pin Descriptions**

PIN	FUNCTION
V+	System Power Supply Input (+1.65V to +3.6V)
GND	Ground Connection
IN	Digital Control Input
COM	Analog Switch Common Pin
NO	Analog Switch Normally Open Pin
NC	Analog Switch Normally Closed Pin

**Ordering Information**

PART NO. (BRAND)	TEMP. RANGE (°C)	PACKAGE	PKG. DWG. #
ISL84715IH-T (715I)	-40 to 85	5 Ld SC70 Tape and Reel	P5.049
ISL84715IHZ-T (715I) (See Note)	-40 to 85	5 Ld SC70 Tape and Reel (Pb-Free)	P5.049
ISL84716IH-T (716I)	-40 to 85	5 Ld SC70 Tape and Reel	P5.049
ISL84716IHZ-T (716I) (See Note)	-40 to 85	5 Ld SC70 Tape and Reel (Pb-Free)	P5.049

NOTE: Intersil Pb-free products employ special Pb-free material sets; molding compounds/die attach materials and 100% matte tin plate termination finish, which is compatible with both SnPb and Pb-free soldering operations. Intersil Pb-free products are MSL classified at Pb-free peak reflow temperatures that meet or exceed the Pb-free requirements of IPC/JEDEC J Std-020B.

**Absolute Maximum Ratings**

V+ to GND	-0.3 to 4.8V
Input Voltages	
NO, NC, IN (Note 2)	-0.3 to ((V+) + 0.3V)
Output Voltages	
COM (Note 2)	-0.3 to ((V+) + 0.3V)
Continuous Current NO, NC, or COM	±300mA
Peak Current NO, NC, or COM (Pulsed 1ms, 10% Duty Cycle, Max)	± 600mA
ESD Rating:	
HBM >	>4kV
MM	>300V
CDM	>1000V

**Thermal Information**

Thermal Resistance (Typical, Note 3)	$\theta_{JA}$ (°C/W)
5 Ld SC70 Package	660
Maximum Junction Temperature (Plastic Package)	150°C
Maximum Storage Temperature Range	-65°C to 150°C
Maximum Lead Temperature (Soldering 10s) (Lead Tips Only)	300°C

**Operating Conditions**

Temperature Range	
ISL8471XIH	-40°C to 85°C

CAUTION: Stresses above those listed in "Absolute Maximum Ratings" may cause permanent damage to the device. This is a stress only rating and operation of the device at these or any other conditions above those indicated in the operational sections of this specification is not implied.

NOTES:

2. Signals on NC, NO, IN, or COM exceeding V+ or GND are clamped by internal diodes. Limit forward diode current to maximum current ratings.
3.  $\theta_{JA}$  is measured with the component mounted on a high effective thermal conductivity test board in free air. See Tech Brief TB379 for details.

**Electrical Specifications - 3V Supply**

Test Conditions: V+ = +2.7V to +3.6V, GND = 0V, V<sub>INH</sub> = 1.4V, V<sub>INL</sub> = 0.5V (Notes 4, 6), Unless Otherwise Specified

PARAMETER	TEST CONDITIONS	TEMP (°C)	(NOTE 5) MIN	TYP	(NOTE 5) MAX	UNITS
<b>ANALOG SWITCH CHARACTERISTICS</b>						
Analog Signal Range, V <sub>ANALOG</sub>		Full	0	-	V+	V
ON Resistance, R <sub>ON</sub>	V+ = 2.7V, I <sub>COM</sub> = 100mA, V <sub>NO</sub> or V <sub>NC</sub> = 1.5V (See Figure 4)	25	-	0.26	0.4	Ω
		Full	-	-	0.45	Ω
R <sub>ON</sub> Flatness, R <sub>FLAT(ON)</sub>	V+ = 2.7V, I <sub>COM</sub> = 100mA, V <sub>NO</sub> or V <sub>NC</sub> = 0.6V, 1.5V, 2.1V (Note 7)	25	-	0.038	0.07	Ω
		Full	-	-	0.09	Ω
NO or NC OFF Leakage Current, I <sub>NO(OFF)</sub> or I <sub>NC(OFF)</sub>	V+ = 3.3V, V <sub>COM</sub> = 0.3V, 3V, V <sub>NO</sub> or V <sub>NC</sub> = 3V, 0.3V	25	-3	-	3	nA
		Full	-20	-	20	nA
COM OFF Leakage Current, I <sub>COM(OFF)</sub>	V+ = 3.3V, V <sub>COM</sub> = 0.3V, 3V, V <sub>NO</sub> or V <sub>NC</sub> = 3V, 0.3V	25	-3	-	3	nA
		Full	-20	-	20	nA
COM ON Leakage Current, I <sub>COM(ON)</sub>	V+ = 3.3V, V <sub>COM</sub> = 0.3V, 3V, or V <sub>NO</sub> or V <sub>NC</sub> = 0.3V, 3V, or Floating	25	-3	-	3	nA
		Full	-35	-	35	nA
<b>DYNAMIC CHARACTERISTICS</b>						
Turn-ON Time, t <sub>ON</sub>	V+ = 2.7V, V <sub>NO</sub> or V <sub>NC</sub> = 1.5V, R <sub>L</sub> = 50Ω, C <sub>L</sub> = 35pF (See Figure 1, Note 8)	25	-	9	12	ns
		Full	-	-	15	ns
Turn-OFF Time, t <sub>OFF</sub>	V+ = 2.7V, V <sub>NO</sub> or V <sub>NC</sub> = 1.5V, R <sub>L</sub> = 50Ω, C <sub>L</sub> = 35pF (See Figure 1, Note 8)	25	-	5	8	ns
		Full	-	-	11	ns
Charge Injection, Q	V <sub>G</sub> = V+/2, R <sub>G</sub> = 0Ω, C <sub>L</sub> = 1.0nF (See Figure 2)	25	-	70	-	pC
OFF Isolation	R <sub>L</sub> = 50Ω, C <sub>L</sub> = 5pF, f = 1MHz, V <sub>COM</sub> = 1V <sub>RMS</sub> (See Figure 3)	25	-	-45	-	dB
Total Harmonic Distortion	f = 20Hz to 20kHz, V <sub>COM</sub> = 2V <sub>P-P</sub> , R <sub>L</sub> = 32Ω	25	-	0.003	-	%
NO or NC OFF Capacitance, C <sub>OFF</sub>	f = 1MHz, V <sub>NO</sub> or V <sub>NC</sub> = V <sub>COM</sub> = 0V (See Figure 5)	25	-	68	-	pF
COM OFF Capacitance, C <sub>COM(OFF)</sub>	f = 1MHz, V <sub>NO</sub> or V <sub>NC</sub> = V <sub>COM</sub> = 0V (See Figure 5)	25	-	68	-	pF
COM ON Capacitance, C <sub>COM(ON)</sub>	f = 1MHz, V <sub>NO</sub> or V <sub>NC</sub> = V <sub>COM</sub> = 0V (See Figure 5)	25	-	160	-	pF

## ISL84715, ISL84716

### Electrical Specifications - 3V Supply

Test Conditions:  $V_+ = +2.7V$  to  $+3.6V$ ,  $GND = 0V$ ,  $V_{INH} = 1.4V$ ,  $V_{INL} = 0.5V$  (Notes 4, 6), Unless Otherwise Specified **(Continued)**

PARAMETER	TEST CONDITIONS	TEMP (°C)	(NOTE 5) MIN	TYP	(NOTE 5) MAX	UNITS
<b>POWER SUPPLY CHARACTERISTICS</b>						
Power Supply Range		Full	1.65	-	3.6	V
Positive Supply Current, $I_+$	$V_+ = 3.6V$ , $V_{IN} = 0V$ or $V_+$	25	-	0.018	0.05	$\mu A$
		Full	-	-	0.35	$\mu A$
<b>DIGITAL INPUT CHARACTERISTICS</b>						
Input Voltage Low, $V_{INL}$		Full	-	-	0.5	V
Input Voltage High, $V_{INH}$		Full	1.4	-	-	V
Input Current, $I_{INH}$ , $I_{INL}$	$V_+ = 3.6V$ , $V_{IN} = 0V$ or $V_+$	Full	-1	-	1	$\mu A$

**NOTES:**

4.  $V_{IN}$  = input voltage to perform proper function.
5. The algebraic convention, whereby the most negative value is a minimum and the most positive a maximum, is used in this data sheet.
6. Parts are 100% tested at +25°C. Limits across the full temperature range are guaranteed by design and correlation.
7. Flatness is defined as the difference between maximum and minimum value of on-resistance over the specified analog signal range.
8. Guaranteed by design.

### Electrical Specifications - 1.8V Supply

Test Conditions:  $V_+ = +1.8V$ ,  $GND = 0V$ ,  $V_{INH} = 1V$ ,  $V_{INL} = 0.4V$  (Notes 4, 6), Unless Otherwise Specified

PARAMETER	TEST CONDITIONS	TEMP (°C)	(NOTE 5) MIN	TYP	(NOTE 5) MAX	UNITS
<b>ANALOG SWITCH CHARACTERISTICS</b>						
Analog Signal Range, $V_{ANALOG}$		Full	0	-	$V_+$	V
ON Resistance, $R_{ON}$	$V_+ = 1.8V$ , $I_{COM} = 10mA$ , $V_{NO}$ or $V_{NC} = 0.9V$ (See Figure 4)	25	-	0.45	0.6	$\Omega$
		Full	-	-	0.8	$\Omega$
NO or NC OFF Leakage Current, $I_{NO(OFF)}$ or $I_{NC(OFF)}$	$V_+ = 1.8V$ , $V_{COM} = 0.3V, 1.5V$ , $V_{NO}$ or $V_{NC} = 1.5V, 0.3V$	25	-2	-	2	nA
		Full	-20	-	20	nA
COM OFF Leakage Current, $I_{COM(OFF)}$	$V_+ = 1.8V$ , $V_{COM} = 0.3V, 1.5V$ , $V_{NO}$ or $V_{NC} = 1.5V, 0.3V$	25	-2	-	2	nA
		Full	-20	-	20	nA
COM ON Leakage Current, $I_{COM(ON)}$	$V_+ = 1.8V$ , $V_{COM} = 0.3V, 1.5V$ , or $V_{NO}$ or $V_{NC} = 0.3V, 1.5V$ , or Floating	25	-1	-	1	nA
		Full	-20	-	20	nA
<b>DYNAMIC CHARACTERISTICS</b>						
Turn-ON Time, $t_{ON}$	$V_+ = 1.8V$ , $V_{NO}$ or $V_{NC} = 1.5V$ , $R_L = 50\Omega$ , $C_L = 35pF$ (See Figure 1, Note 8)	25	-	17	22	ns
		Full	-	-	24	ns
Turn-OFF Time, $t_{OFF}$	$V_+ = 1.8V$ , $V_{NO}$ or $V_{NC} = 1.5V$ , $R_L = 50\Omega$ , $C_L = 35pF$ (See Figure 1, Note 8)	25	-	7	11	ns
		Full	-	-	14	ns
Charge Injection, Q	$V_G = V_+/2$ , $R_G = 0\Omega$ , $C_L = 1.0nF$ (See Figure 2)	25	-	60	-	pC
<b>POWER SUPPLY CHARACTERISTICS</b>						
Positive Supply Current, $I_+$	$V_{IN} = 0V$ or $V_+$	25	-	0.018	0.05	$\mu A$
		Full	-	-	0.35	$\mu A$
<b>DIGITAL INPUT CHARACTERISTICS</b>						
Input Voltage Low, $V_{INL}$		Full	-	-	0.4	V
Input Voltage High, $V_{INH}$		Full	1	-	-	V
Input Current, $I_{INH}$ , $I_{INL}$	$V_{IN} = 0V$ or $V_+$	Full	-1	-	1	$\mu A$

Test Circuits and Waveforms

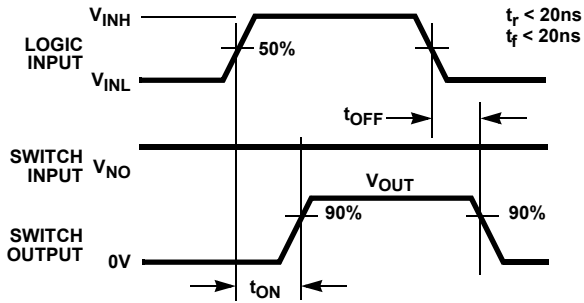

Logic input waveform is inverted for switches that have the opposite logic sense.

FIGURE 1A. MEASUREMENT POINTS

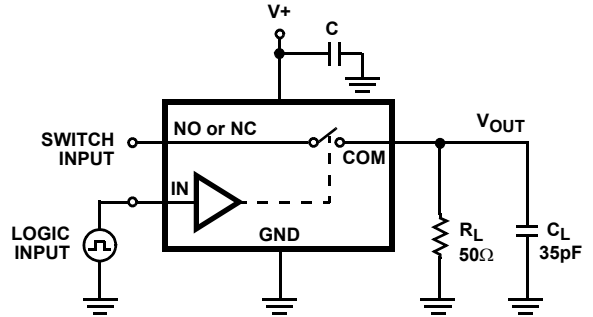

Repeat test for all switches.  $C_L$  includes fixture and stray capacitance.

$$V_{OUT} = V_{(NO \text{ or } NC)} \frac{R_L}{R_L + R_{(ON)}}$$

FIGURE 1B. TEST CIRCUIT

FIGURE 1. SWITCHING TIMES

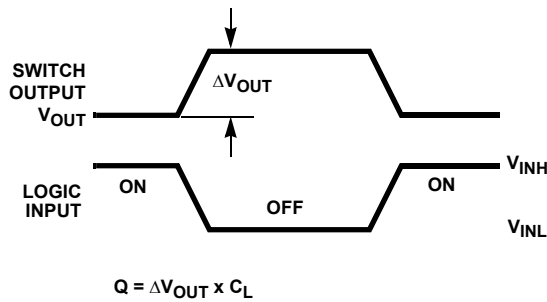

FIGURE 2A. MEASUREMENT POINTS

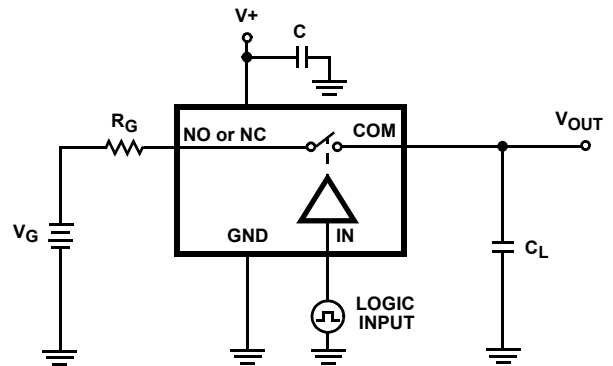

FIGURE 2B. TEST CIRCUIT

FIGURE 2. CHARGE INJECTION

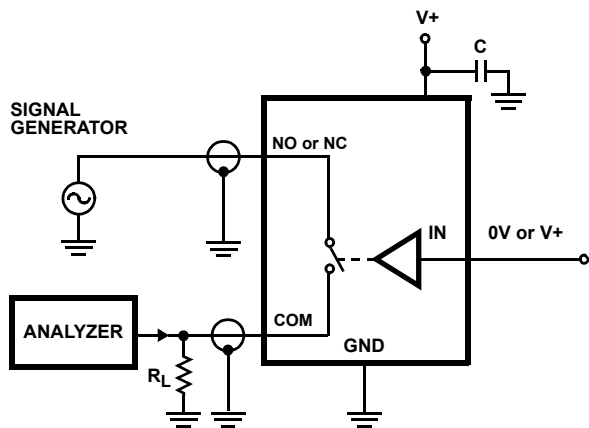

FIGURE 3. OFF ISOLATION TEST CIRCUIT

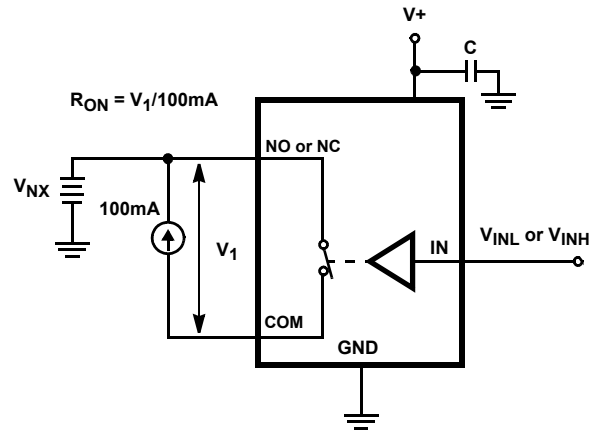

FIGURE 4.  $R_{ON}$  TEST CIRCUIT

## Test Circuits and Waveforms (Continued)

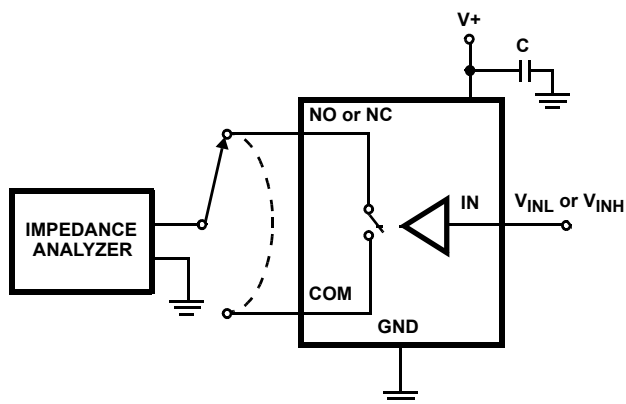

FIGURE 5. CAPACITANCE TEST CIRCUIT

### Detailed Description

The ISL84715 and ISL84716 are bidirectional, single pole/single throw (SPST) analog switches. They offer precise switching capability from a single 1.65V to 3.6V supply with ultra low on-resistance and high speed operation. With a single supply of 3V the typical on-resistance is only  $0.26\Omega$ , with a typical turn-on and turn-off time of:  $t_{ON} = 9\text{ns}$ ,  $t_{OFF} = 5\text{ns}$ . The devices are especially well suited for portable battery powered equipment due to its low operating supply voltage (1.65V), low power consumption ( $1.05\mu\text{W}$ ), low leakage currents (35nA max), and the tiny SC70 packaging.

The ISL84715 is a normally open (NO) SPST analog switch. The ISL84716 is a normally closed (NC) SPST analog switch.

### Supply Sequencing And Overvoltage Protection

With any CMOS device, proper power supply sequencing is required to protect the device from excessive input currents which might permanently damage the IC. All I/O pins contain ESD protection diodes from the pin to V+ and to GND (see Figure 6). To prevent forward biasing these diodes, V+ must be applied before any input signals, and the input signal voltages must remain between V+ and GND. If these conditions cannot be guaranteed, then one of the following two protection methods should be employed.

Logic inputs can easily be protected by adding a  $1\text{k}\Omega$  resistor in series with the input (see Figure 6). The resistor limits the input current below the threshold that produces permanent damage, and the sub-microamp input current produces an insignificant voltage drop during normal operation.

This method is not acceptable for the signal path inputs. Adding a series resistor to the switch input defeats the purpose of using a low  $R_{ON}$  switch, so two small signal diodes can be added in series with the supply pins to provide overvoltage protection for all pins (see Figure 6). These additional diodes limit the analog signal from 1V below V+ to 1V above GND. The low leakage current performance is unaffected by this approach, but the switch signal range is reduced and the resistance may increase, especially at low supply voltages.

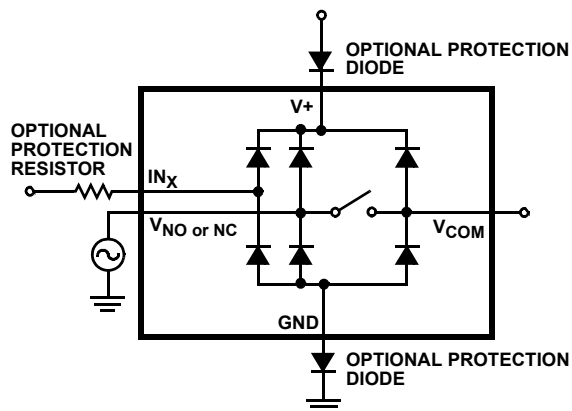

FIGURE 6. OVERVOLTAGE PROTECTION

### Power-Supply Considerations

The ISL8471X construction is typical of most single supply CMOS analog switches in that they have two supply pins: V+ and GND. V+ and GND drive the internal CMOS switches and set their analog voltage limits. Unlike switches with a 4V maximum supply voltage, the ISL84714 4.8V maximum

supply voltage provides plenty of room for the 10% tolerance of 3.6V supplies, as well as room for overshoot and noise spikes.

The minimum recommended supply voltage is 3.6V but the part will operate with a supply below 1.5V. It is important to note that the input signal range, switching times, and on-resistance degrade at lower supply voltages. Refer to the electrical specification tables and *Typical Performance* curves for details.

V+ and GND also power the internal logic and level shifter. The level shifter converts the input logic levels to switched V+ and GND signals to drive the analog switch gate terminals.

This family of switches cannot be operated with bipolar supplies, because the input switching point becomes negative in this configuration.

**Logic-Level Thresholds**

This switch family is 1.8V CMOS compatible (0.5V and 1.4V) over a supply range of 2V to 3.6V (see Figure 13). At 3.6V the  $V_{IH}$  level is about 1.1V. This is still below the 1.8V CMOS guaranteed high output minimum level of 1.4V, but noise margin is reduced.

The digital input stages draw supply current whenever the digital input voltage is not at one of the supply rails. Driving the digital input signals from GND to V+ with a fast transition time minimizes power dissipation.

**High-Frequency Performance**

In 50Ω systems, signal response is reasonably flat even past 100MHz (see Figure 14). The frequency response is very

consistent over a wide V+ range, and for varying analog signal levels.

An OFF switch acts like a capacitor and passes higher frequencies with less attenuation, resulting in signal feedthrough from a switch's input to its output. Off Isolation is the resistance to this feedthrough. Figure 15 details the high Off Isolation rejection provided by this family. At 1MHz, Off Isolation is about 45dB in 50Ω systems, decreasing approximately 20dB per decade as frequency increases. Higher load impedances decrease Off Isolation and Crosstalk rejection due to the voltage divider action of the switch OFF impedance and the load impedance.

**Leakage Considerations**

Reverse ESD protection diodes are internally connected between each analog-signal pin and both V+ and GND. One of these diodes conducts if any analog signal exceeds V+ or GND.

Virtually all the analog leakage current comes from the ESD diodes to V+ or GND. Although the ESD diodes on a given signal pin are identical and therefore fairly well balanced, they are reverse biased differently. Each is biased by either V+ or GND and the analog signal. This means their leakages will vary as the signal varies. The difference in the two diode leakages to the V+ and GND pins constitutes the analog-signal-path leakage current. All analog leakage current flows between each pin and one of the supply terminals, not to the other switch terminal. This is why both sides of a given switch can show leakage currents of the same or opposite polarity. There is no connection between the analog signal paths and V+ or GND.

**Typical Performance Curves**  $T_A = 25^\circ\text{C}$ , Unless Otherwise Specified

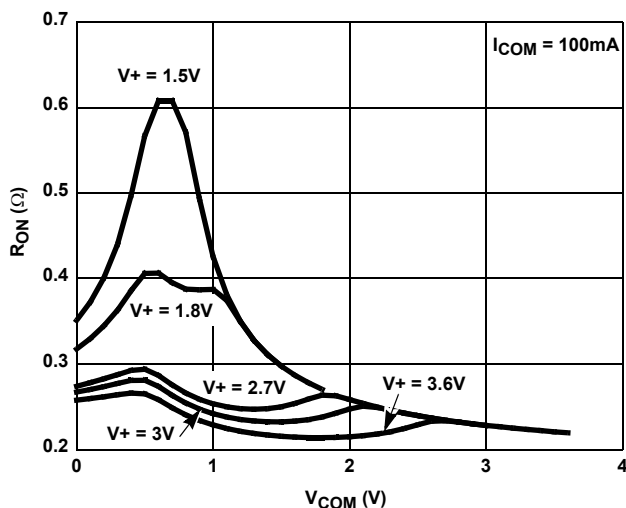

FIGURE 7. ON RESISTANCE vs SUPPLY VOLTAGE vs SWITCH VOLTAGE

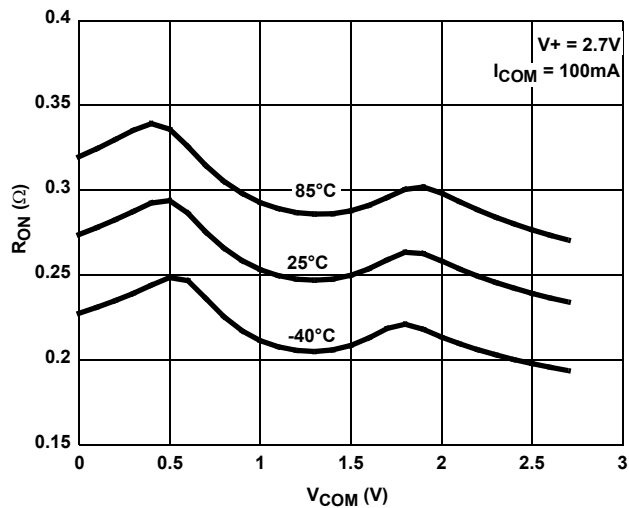

FIGURE 8. ON RESISTANCE vs SWITCH VOLTAGE

**Typical Performance Curves**  $T_A = 25^\circ\text{C}$ , Unless Otherwise Specified (Continued)

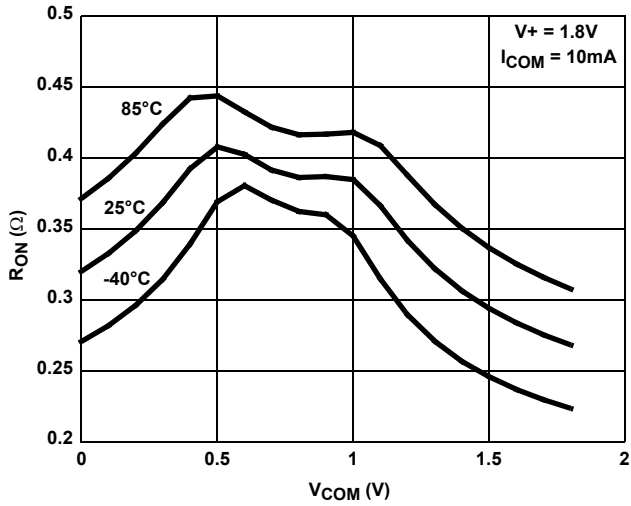

FIGURE 9. ON RESISTANCE vs SWITCH VOLTAGE

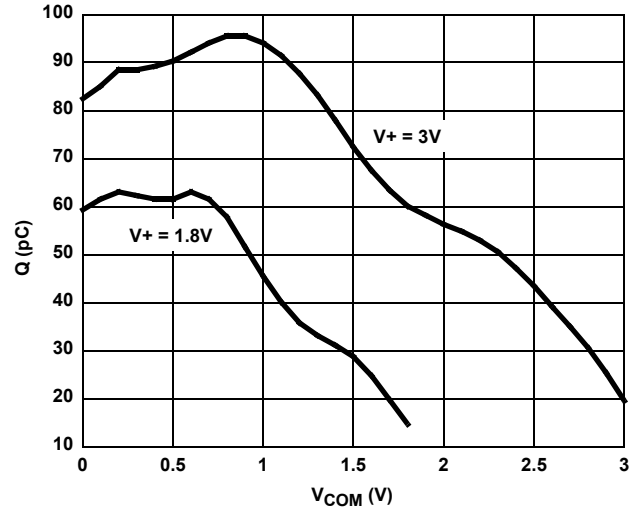

FIGURE 10. CHARGE INJECTION vs SWITCH VOLTAGE

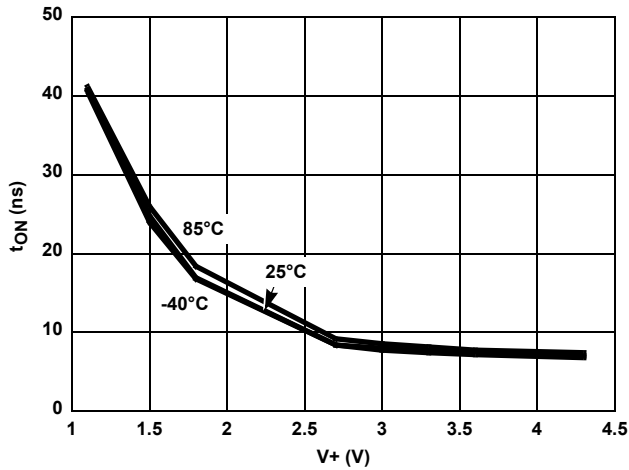

FIGURE 11. TURN - ON TIME vs SUPPLY VOLTAGE

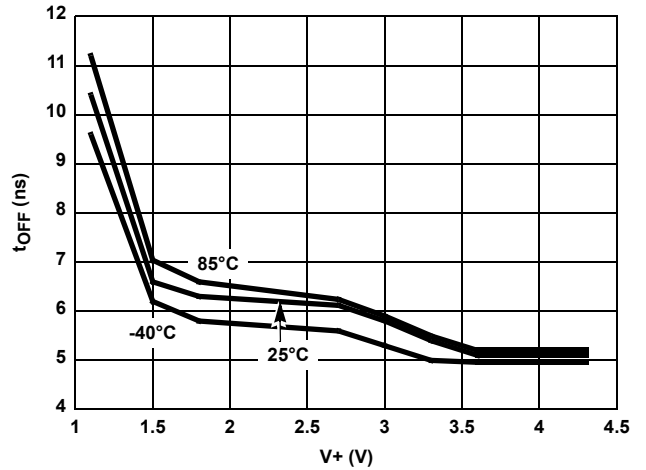

FIGURE 12. TURN - OFF TIME vs SUPPLY VOLTAGE

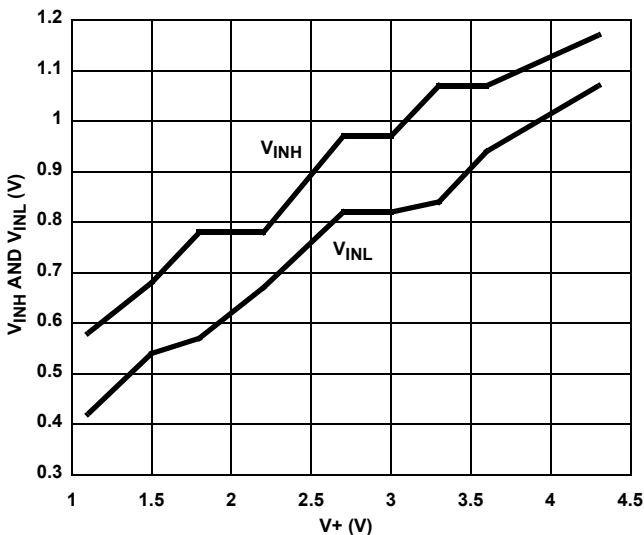

FIGURE 13. DIGITAL SWITCHING POINT vs SUPPLY VOLTAGE

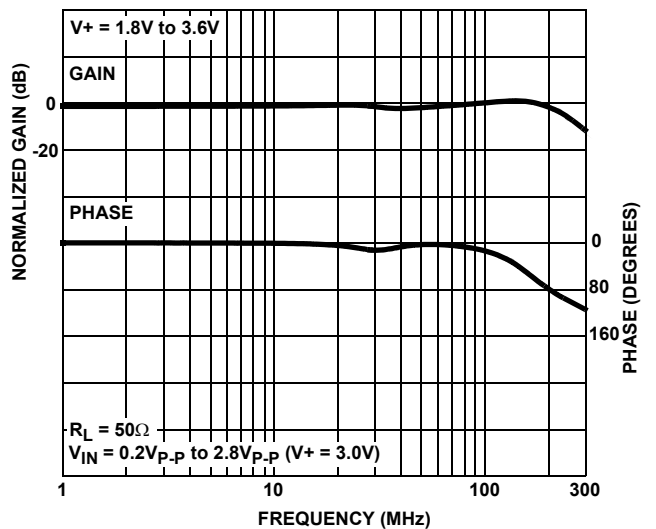

FIGURE 14. FREQUENCY RESPONSE

**Typical Performance Curves**  $T_A = 25^\circ\text{C}$ , Unless Otherwise Specified (Continued)

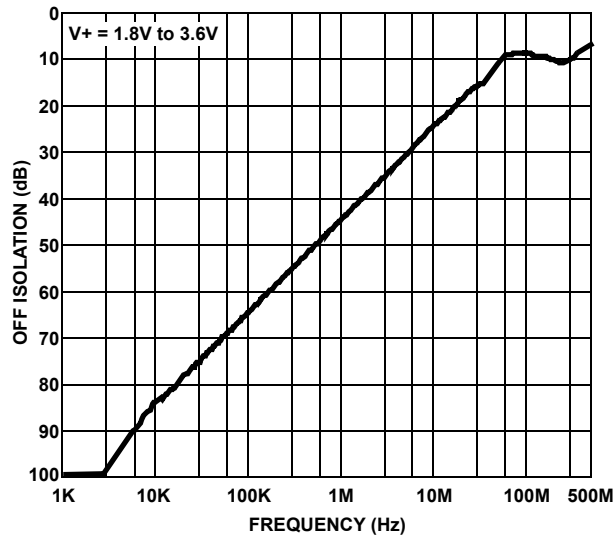

FIGURE 15. OFF ISOLATION

**Die Characteristics**

**SUBSTRATE POTENTIAL (POWERED UP):**

GND

**TRANSISTOR COUNT: 57**

**PROCESS:**

Submicron CMOS

Small Outline Transistor Plastic Packages (SC70-5)

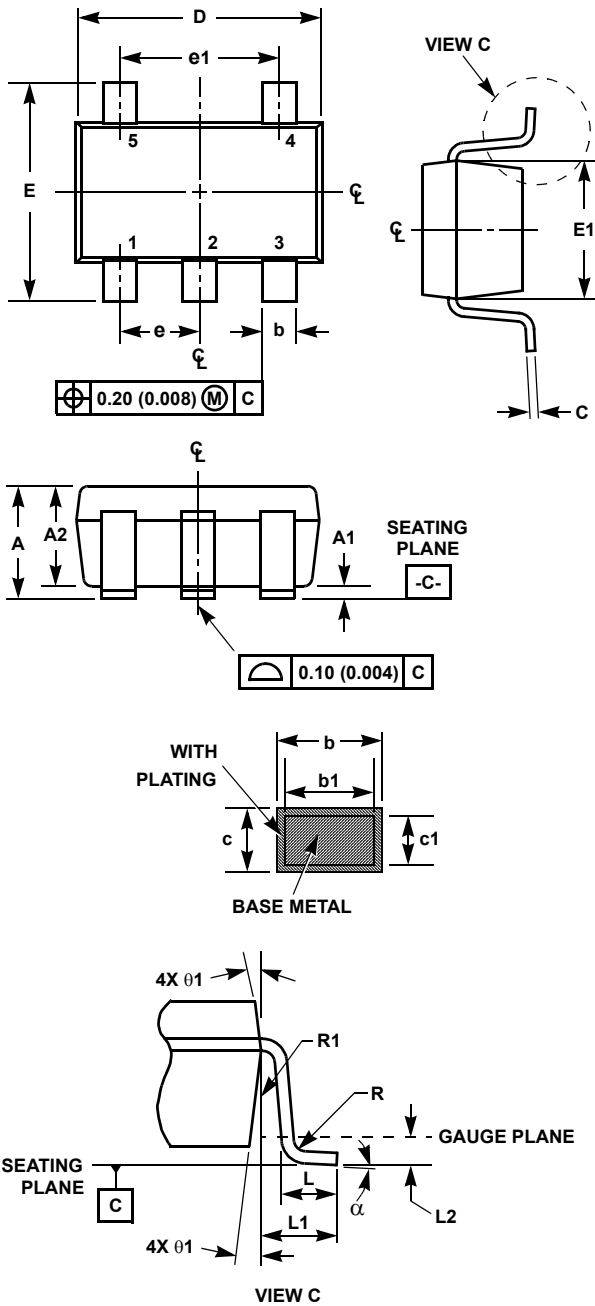

P5.049

5 LEAD SMALL OUTLINE TRANSISTOR PLASTIC PACKAGE

SYMBOL	INCHES		MILLIMETERS		NOTES
	MIN	MAX	MIN	MAX	
A	0.031	0.043	0.80	1.10	-
A1	0.000	0.004	0.00	0.10	-
A2	0.031	0.039	0.80	1.00	-
b	0.006	0.012	0.15	0.30	-
b1	0.006	0.010	0.15	0.25	-
c	0.003	0.009	0.08	0.22	6
c1	0.003	0.009	0.08	0.20	6
D	0.073	0.085	1.85	2.15	3
E	0.071	0.094	1.80	2.40	-
E1	0.045	0.053	1.15	1.35	3
e	0.0256 Ref		0.65 Ref		-
e1	0.0512 Ref		1.30 Ref		-
L	0.010	0.018	0.26	0.46	4
L1	0.017 Ref.		0.420 Ref.		-
L2	0.006 BSC		0.15 BSC		-
$\alpha$	0°	8°	0°	8°	-
N	5		5		5
R	0.004	-	0.10	-	-
R1	0.004	0.010	0.15	0.25	-

Rev. 2 9/03

NOTES:

1. Dimensioning and tolerances per ASME Y14.5M-1994.
2. Package conforms to EIAJ SC70 and JEDEC MO-203AA.
3. Dimensions D and E1 are exclusive of mold flash, protrusions, or gate burrs.
4. Footlength L measured at reference to gauge plane.
5. "N" is the number of terminal positions.
6. These Dimensions apply to the flat section of the lead between 0.08mm and 0.15mm from the lead tip.
7. Controlling dimension: MILLIMETER. Converted inch dimensions are for reference only.

All Intersil U.S. products are manufactured, assembled and tested utilizing ISO9000 quality systems.

Intersil Corporation's quality certifications can be viewed at [www.intersil.com/design/quality](http://www.intersil.com/design/quality)

*Intersil products are sold by description only. Intersil Corporation reserves the right to make changes in circuit design, software and/or specifications at any time without notice. Accordingly, the reader is cautioned to verify that data sheets are current before placing orders. Information furnished by Intersil is believed to be accurate and reliable. However, no responsibility is assumed by Intersil or its subsidiaries for its use; nor for any infringements of patents or other rights of third parties which may result from its use. No license is granted by implication or otherwise under any patent or patent rights of Intersil or its subsidiaries.*

For information regarding Intersil Corporation and its products, see [www.intersil.com](http://www.intersil.com)