

### 3A, 80V, 0.800 Ohm, Logic Level, N-Channel Power MOSFETs

The RFD3N08L and RFD3N08LSM are N-Channel enhancement mode silicon gate power field effect transistors specifically designed for use with logic level (5V) driving sources in applications such as programmable controllers, automotive switching, and solenoid drivers. This performance is accomplished through a special gate oxide design which provides full rated conductance at gate biases in the 3V to 5V range, thereby facilitating true on-off power control directly from logic circuit supply voltages.

Formerly developmental type TA09922.

### Ordering Information

PART NUMBER	PACKAGE	BRAND
RFD3N08L	TO-251AA	F3N08L
RFD3N08LSM	TO-252AA	F3N08L

NOTE: When ordering, include the entire part number. Add the suffix 9A to obtain the TO-252AA variant in tape and reel, i.e. RFD3N08LSM9A

### Features

- 3A, 80V
- $r_{DS(ON)} = 0.800\Omega$
- Temperature Compensating PSPICE® Model
- On Resistance vs Gate Drive Voltage Curves
- Peak Current vs Pulse Width Curve
- UIS Rating Curve
- 175°C Operating Temperature
- Related Literature
  - TB334 "Guidelines for Soldering Surface Mount Components to PC Boards"

### Symbol

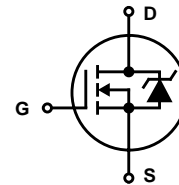

### Packaging

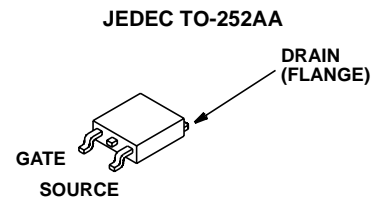
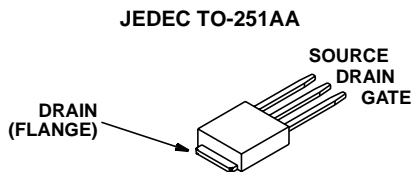

# RFD3N08L, RFD3N08LSM

## Absolute Maximum Ratings $T_C = 25^\circ\text{C}$ , Unless Otherwise Specified

	RFD3N08L, RFD3N08LSM	UNITS
Drain to Source Voltage (Note 1) . . . . .	80	V
Drain to Gate Voltage ( $R_{GS} = 20\text{K}\Omega$ ) (Note 1) . . . . .	80	V
Gate to Source Voltage . . . . .	$\pm 10$	V
Continuous Drain Current . . . . .	3	A
Pulsed Drain Current (Figures 3, 5) (Note 3) . . . . .	Refer to Peak Current Curve	
Maximum Power Dissipation . . . . .	30	W
Derate Above $25^\circ\text{C}$ . . . . .	0.2	$\text{W}/^\circ\text{C}$
Pulsed Avalanche Energy Rating (Figure 6) (Note 4) . . . . .	Refer to UIS Curve	
Operating and Storage Temperature Range . . . . .	-55 to 175	$^\circ\text{C}$
Maximum Temperature for Soldering		
Leads at 0.063in (1.6mm) from Case for 10s. . . . .	300	$^\circ\text{C}$
Package Body for 10s, See Techbrief 334 . . . . .	260	$^\circ\text{C}$

*CAUTION: Stresses above those listed in "Absolute Maximum Ratings" may cause permanent damage to the device. This is a stress only rating and operation of the device at these or any other conditions above those indicated in the operational sections of this specification is not implied.*

**NOTE:**

1.  $T_J = 25^\circ\text{C}$  to  $150^\circ\text{C}$ .

## Electrical Specifications $T_C = 25^\circ\text{C}$ , Unless Otherwise Specified

PARAMETER	SYMBOL	TEST CONDITIONS	MIN	TYP	MAX	UNITS
Drain to Source Breakdown Voltage	$BV_{DSS}$	$I_D = 250\mu\text{A}$ , $V_{GS} = 0\text{V}$ (Figure 12)	80	-	-	V
Gate to Threshold Voltage	$V_{GS(TH)}$	$V_{GS} = V_{DS}$ , $I_D = 250\mu\text{A}$ (Figure 11)	1	-	2.5	V
Zero Gate Voltage Drain Current	$I_{DSS}$	$V_{DS} = \text{Rated } BV_{DSS}$ , $V_{GS} = 0\text{V}$	-	-	25	$\mu\text{A}$
		$V_{DS} = 0.8 \times \text{Rated } BV_{DSS}$ , $V_{GS} = 0\text{V } 125^\circ\text{C}$	-	-	250	$\mu\text{A}$
Gate to Source Leakage Current	$I_{GSS}$	$V_{GS} = \pm 10\text{V}$	-	-	$\pm 100$	nA
Drain to Source On Resistance (Note 2)	$r_{DS(ON)}$	$I_D = 3\text{A}$ , $V_{GS} = 5\text{V}$ , (Figures 9, 10)	-	-	0.800	$\Omega$
Turn-On Time	$t_{(ON)}$	$V_{DD} = 40\text{V}$ , $I_D = 3\text{A}$ , $R_L = 13.3\Omega$ , $V_{GS} = 5\text{V}$ , $R_G = 25\Omega$ , (Figures 13, 15, 18, 19)	-	-	75	ns
Turn-On Delay Time	$t_{d(ON)}$		-	15	-	ns
Rise Time	$t_r$		-	45	-	ns
Turn-Off Delay Time	$t_{d(OFF)}$		-	22	-	ns
Fall Time	$t_f$		-	15	-	ns
Turn-Off Time	$t_{(OFF)}$		-	-	45	ns
Total Gate Charge	$Q_g(\text{TOT})$	$V_{GS} = 0\text{V to } 10\text{V}$	-	6.8	8.5	nC
Gate Charge at 5V	$Q_g(5)$	$V_{GS} = 0\text{V to } 5\text{V}$				
Threshold Gate Charge	$Q_g(\text{TH})$	$V_{GS} = 0\text{V to } 1\text{V}$				
Input Capacitance	$C_{ISS}$	$V_{DS} = 25\text{V}$ , $V_{GS} = 0\text{V}$ , $f = 1\text{MHz}$ , (Figure 14)	-	-	125	pF
Output Capacitance	$C_{OSS}$		-	-	55	pF
Reverse Transfer Characteristics	$C_{RSS}$		-	-	15	pF
Thermal Resistance, Junction to Case	$R_{\theta JC}$		-	-	5.0	$^\circ\text{C}/\text{W}$
Thermal Resistance, Junction to Ambient	$R_{\theta JA}$		-	-	100	$^\circ\text{C}/\text{W}$

## Source to Drain Diode Ratings and Specifications

PARAMETER	SYMBOL	TEST CONDITIONS	MIN	TYP	MAX	UNITS
Source to Drain Diode Voltage (Note 2)	$V_{SD}$	$I_{SD} = 3\text{A}$	-	-	1.25	V
Reverse Recovery Time	$t_{rr}$	$I_{SD} = 3\text{A}$ , $dI_{SD}/dt = 100\text{A}/\mu\text{s}$	-	-	85	ns

**NOTES:**

2. Pulsed: pulse duration =  $300\mu\text{s}$  max, duty cycle = 2%.
3. Repetitive rating: pulse width limited by maximum junction temperature. See Transient Thermal Impedance curve (Figure 3).
4. Refer to Intersil Application Notes AN9321 and AN9322.

Typical Performance Curves Unless Otherwise Specified

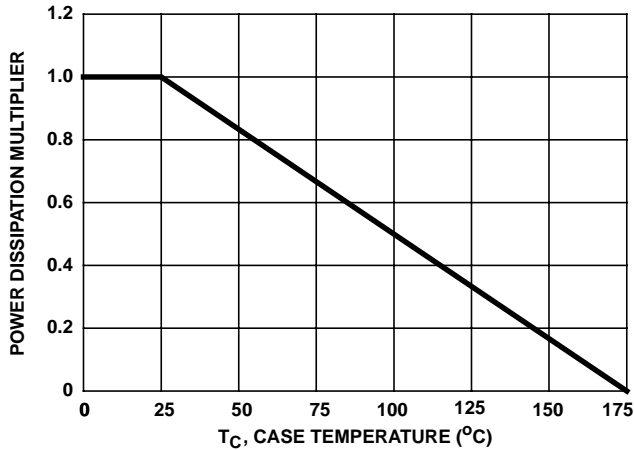

FIGURE 1. NORMALIZED POWER DISSIPATION vs CASE TEMPERATURE

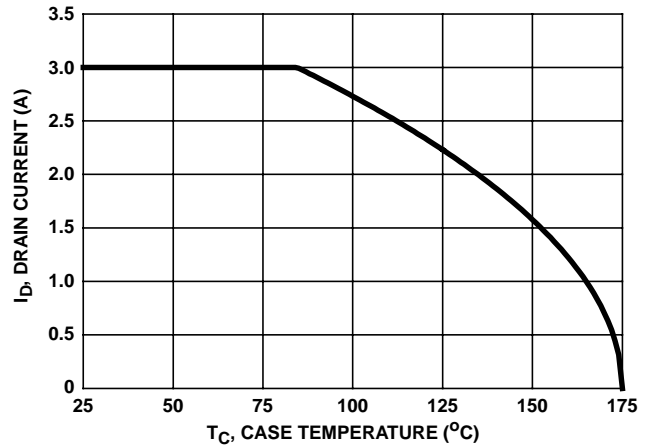

FIGURE 2. MAXIMUM CONTINUOUS DRAIN CURRENT vs TEMPERATURE

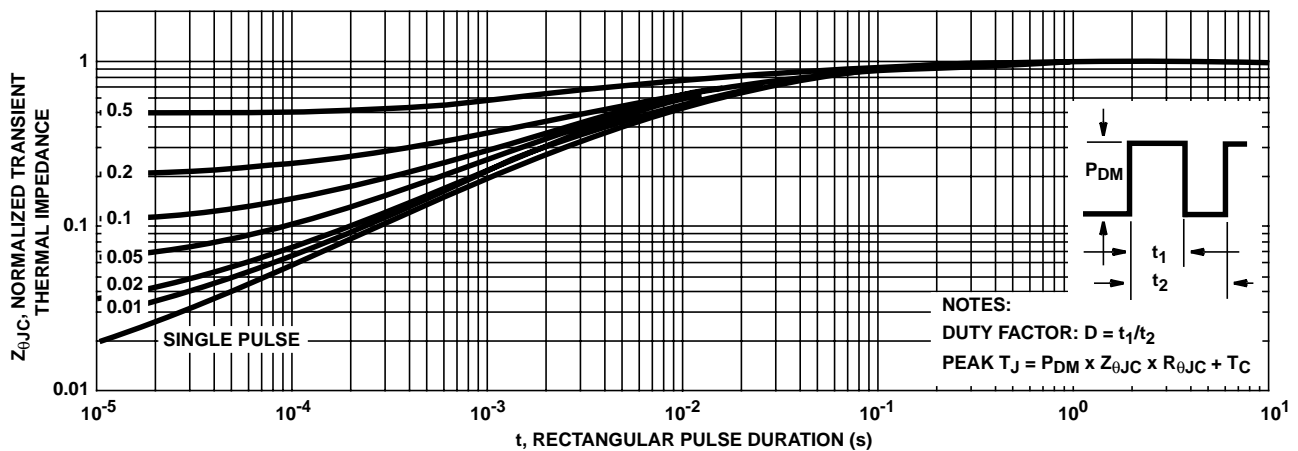

FIGURE 3. NORMALIZED MAXIMUM TRANSIENT THERMAL IMPEDANCE

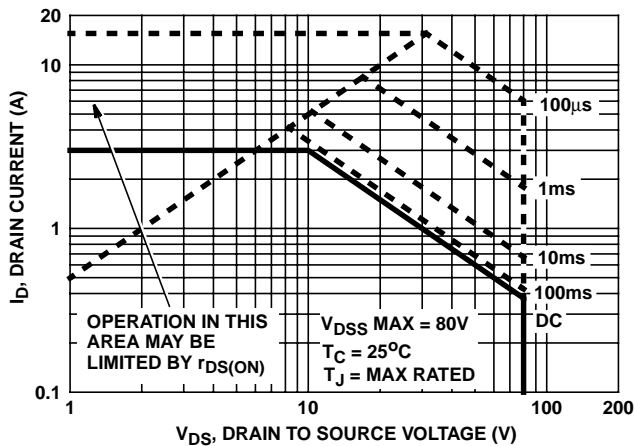

FIGURE 4. FORWARD BIAS SAFE OPERATING AREA

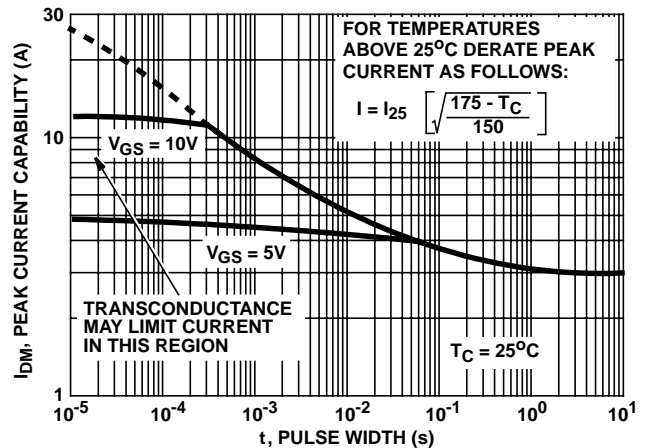
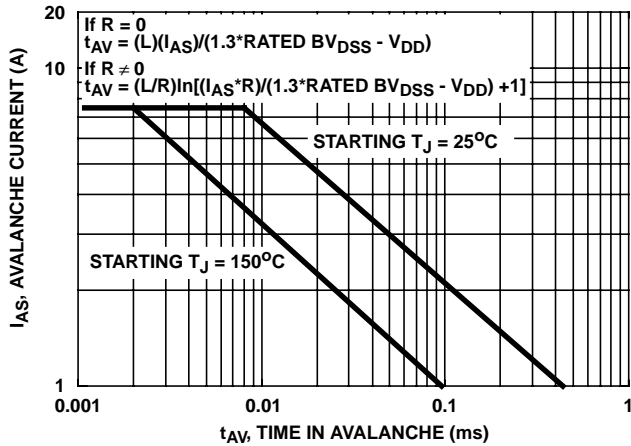

FIGURE 5. PEAK CURRENT CAPABILITY

Typical Performance Curves Unless Otherwise Specified (Continued)



NOTE: Refer to Intersil Application Notes AN9321 and AN9322.

FIGURE 6. UNCLAMPED INDUCTIVE SWITCHING CAPABILITY

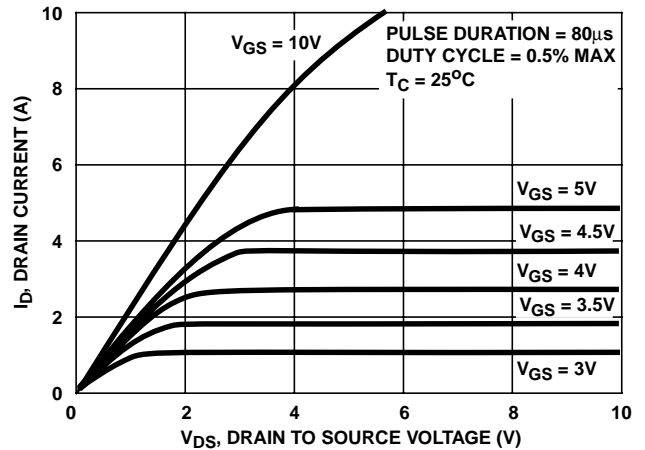

FIGURE 7. SATURATION CHARACTERISTICS

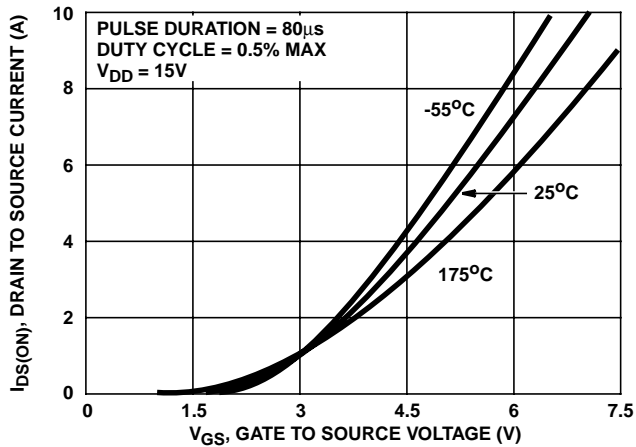

FIGURE 8. TRANSFER CHARACTERISTICS

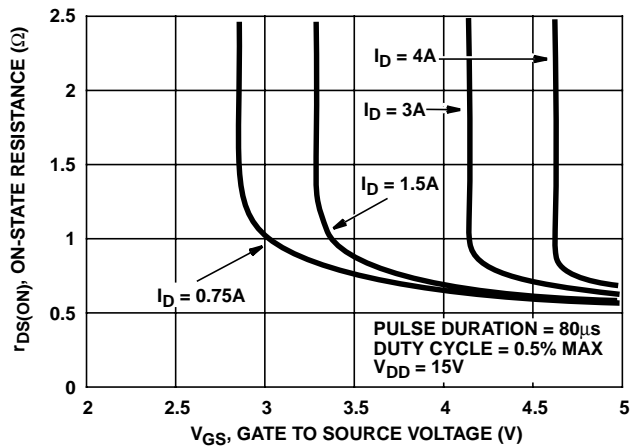

FIGURE 9. DRAIN TO SOURCE ON RESISTANCE vs GATE VOLTAGE AND DRAIN CURRENT

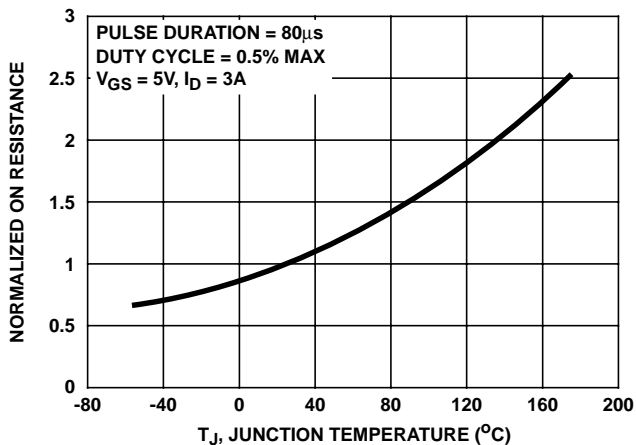

FIGURE 10. NORMALIZED DRAIN TO SOURCE ON RESISTANCE vs JUNCTION TEMPERATURE

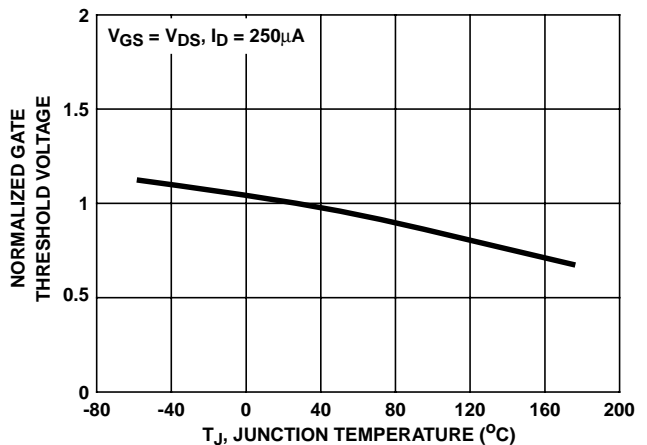

FIGURE 11. NORMALIZED GATE THRESHOLD VOLTAGE vs JUNCTION TEMPERATURE

Typical Performance Curves Unless Otherwise Specified (Continued)

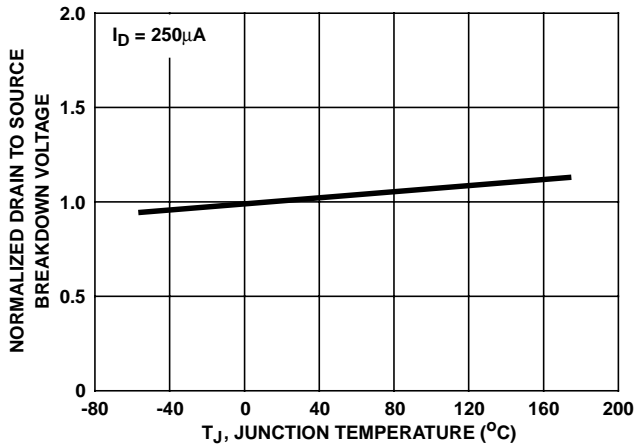

FIGURE 12. NORMALIZED DRAIN TO SOURCE BREAKDOWN VOLTAGE vs JUNCTION TEMPERATURE

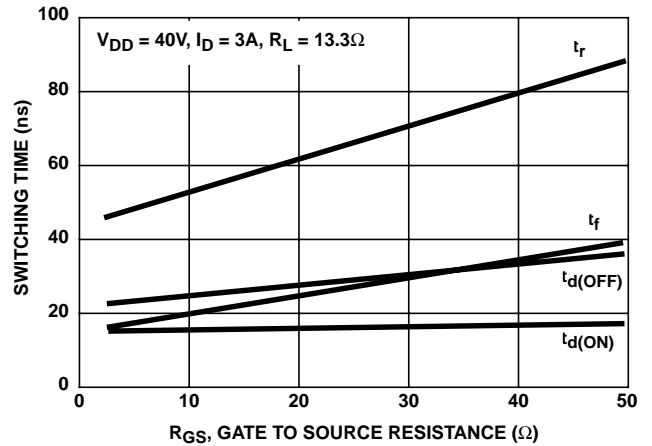

FIGURE 13. SWITCHING TIME vs GATE RESISTANCE

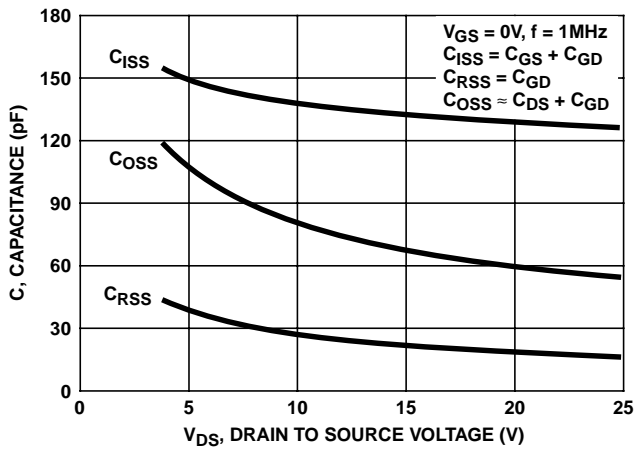
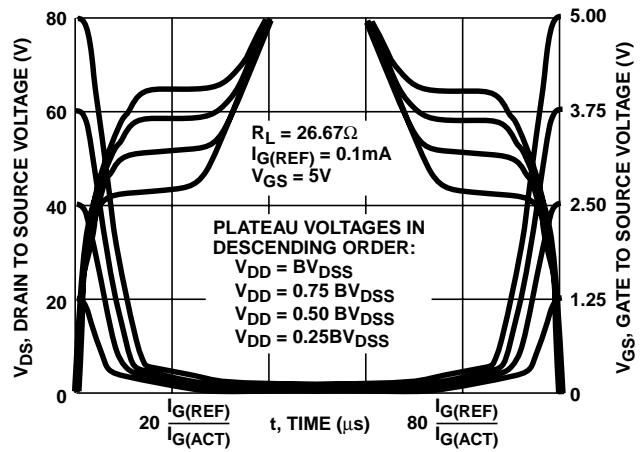

FIGURE 14. CAPACITANCE vs DRAIN TO SOURCE VOLTAGE



NOTE: Refer to Intersil Application Notes AN7254 and AN7260.

FIGURE 15. NORMALIZED SWITCHING WAVEFORMS FOR CONSTANT GATE CURRENT

Test Circuits and Waveforms

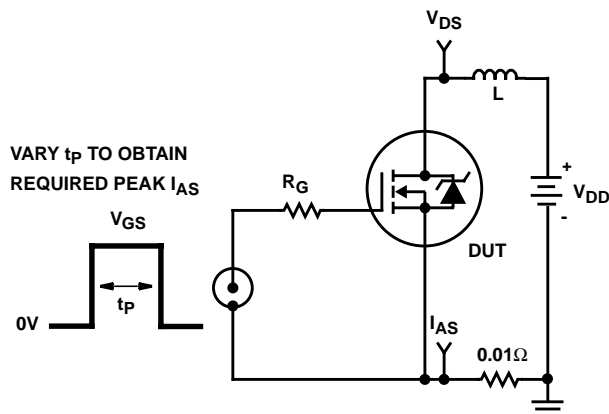

FIGURE 16. UNCLAMPED ENERGY TEST CIRCUIT

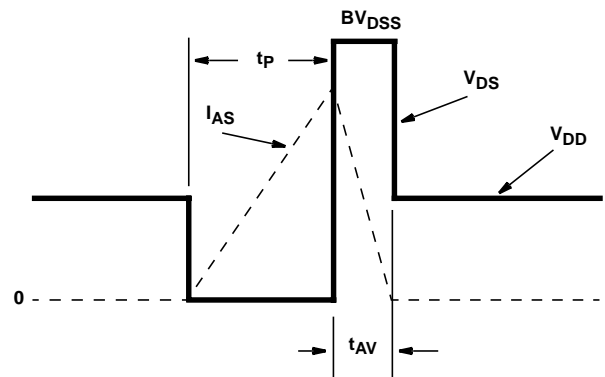

FIGURE 17. UNCLAMPED ENERGY WAVEFORMS

Test Circuits and Waveforms (Continued)

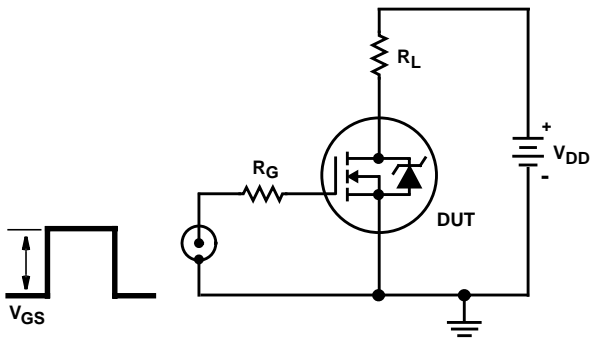

FIGURE 18. SWITCHING TIME TEST CIRCUIT

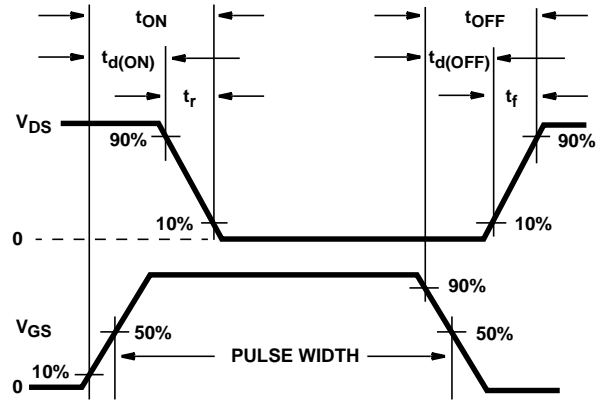

FIGURE 19. RESISTIVE SWITCHING WAVEFORMS

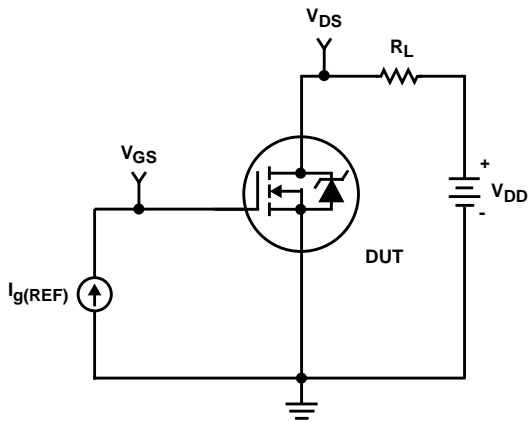

FIGURE 20. GATE CHARGE TEST CIRCUIT

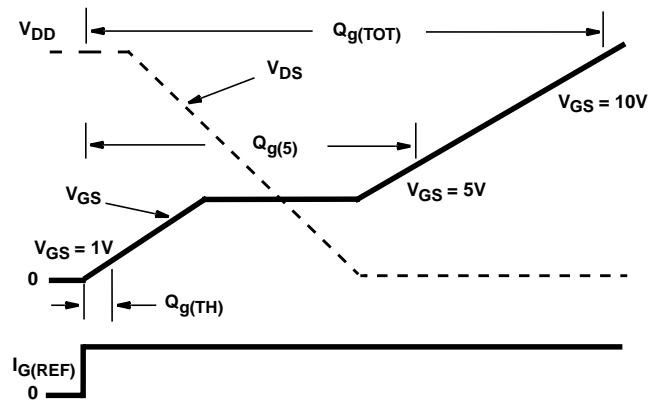

FIGURE 21. GATE CHARGE WAVEFORMS

**PSPICE Electrical Model**

SUBCKT RFD3N08L 2 1 3 ; rev 5/10/95

CA 12 8 4.10e-10  
 CB 15 14 3.25e-10  
 CIN 6 8 1.10e-10

DBODY 7 5 DBDMOD  
 DBREAK 5 11 DBREAKMOD  
 DPLCAP 10 5 DPLCAPMOD

EBREAK 11 7 17 18 93.57  
 EDS 14 8 5 8 1  
 EGS 13 8 6 8 1  
 ESG 6 10 6 8 1  
 EVTHRESH 6 21 19 8 1  
 EZTEMPCO 20 6 18 22 1

IT 8 17 1

LDRAIN 2 5 1e-9  
 LGATE 1 9 5.8e-9  
 LSOURCE 3 7 5.8e-9

MOS1 16 6 8 8 MSTRONG M=0.80  
 MOS2 16 21 8 8 MWEAK M=0.20

RBREAK 17 18 RBREAKMOD 1  
 RDRAIN 50 16 RDRAINMOD 174.2e-3  
 RGATE 9 20 24.9  
 RIN 6 8 1e9  
 RLDRAIN 2 5 10  
 RLGATE 1 9 58  
 RLSOURCE 3 7 58  
 RSCL1 5 51 RSCLMOD 1e-6  
 RSCL2 5 50 1e3  
 RSOURCE 8 7 RSOURCEMOD 200.2e-3  
 RTHRESH 22 8 RTHRESHMOD 1  
 RZTEMPCO 18 19 RZTEMPCOMOD 1

S1A 6 12 13 8 S1AMOD  
 S1B 13 12 13 8 S1BMOD  
 S2A 6 15 14 13 S2AMOD  
 S2B 13 15 14 13 S2BMOD

VBAT 22 19 DC 1

ESCL 51 50 VALUE = {(V(5,51)/ABS(V(5,51)))\*(PWR(V(5,51)/(1e-6\*10),6))}

.MODEL DBDMOD D (IS = 9.90e-14 RS = 6.00e-2 TRS1 = 1.42e-3 TRS2 = -3.58e-6 CJO = 1.40e-10 TT = 5.75e-8 M = 0.4)  
 .MODEL DBREAKMOD D (RS = 2.32 TRS1 = 1.03e-3 TRS2 = -6.17e-11)  
 .MODEL DPLCAPMOD D (CJO = 1.13e-10 IS = 1e-30 N = 10 M=0.6)  
 .MODEL MSTRONG NMOS (VTO = 1.773 KP = 1.70 IS = 1e-30 N = 10 TOX = 1L = 1u W = 1u)  
 .MODEL MWEAK NMOS (VTO = 1.496 KP = 2.09 IS = 1e-30 N = 10 TOX = 1L = 1u W = 1u)  
 .MODEL RBREAKMOD RES (TC1 = 8.19e-4 TC2 = 5.9e-7)  
 .MODEL RDRAINMOD RES (TC1 = 1.55e-2 TC2 = 8.58e-5)  
 .MODEL RDSOURCEMOD RES (TC1 = 0 TC2 = 0)  
 .MODEL RSCLMOD RES (TC1 = 0 TC2 = 0)  
 .MODEL RTHRESHMOD RES (TC1 = -5.0e-4 TC2 = -6.0e-6)  
 .MODEL RZTEMPCOMOD RES (TC1 = -1.19e-3 TC2 = 1.12e-6)  
 .MODEL S1AMOD VSWITCH (RON = 1e-5 ROFF = 0.1 VON = -5.2 VOFF = -3.2)  
 .MODEL S1BMOD VSWITCH (RON = 1e-5 ROFF = 0.1 VON = -3.2 VOFF = -5.2)  
 .MODEL S2AMOD VSWITCH (RON = 1e-5 ROFF = 0.1 VON = -0.60 VOFF = 4.4)  
 .MODEL S2BMOD VSWITCH (RON = 1e-5 ROFF = 0.1 VON = 4.4 VOFF = -0.60)

.ENDS

NOTE:

1. For further discussion of the PSPICE model, consult **A New PSPICE Sub-circuit for the Power MOSFET** Featuring Global Temperature Options; IEEE Power Electronics Specialist Conference Records, 1991.

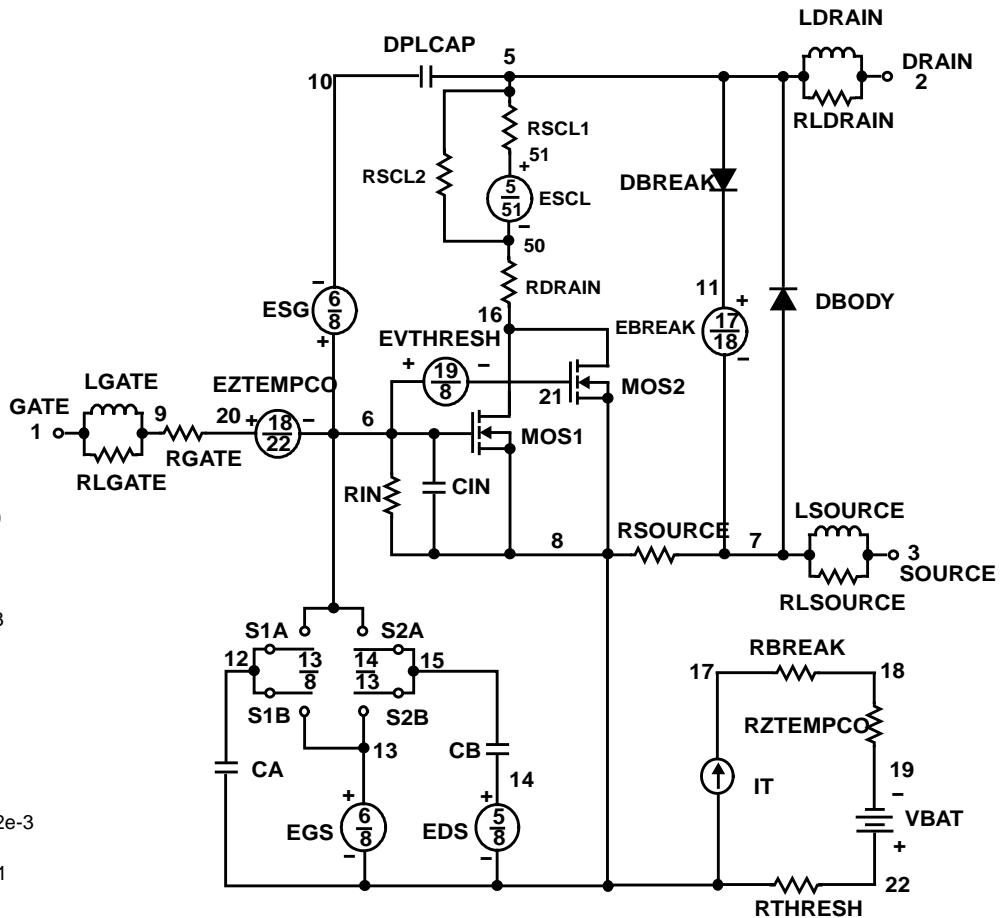

All Intersil semiconductor products are manufactured, assembled and tested under **ISO9000** quality systems certification.

*Intersil semiconductor products are sold by description only. Intersil Corporation reserves the right to make changes in circuit design and/or specifications at any time without notice. Accordingly, the reader is cautioned to verify that data sheets are current before placing orders. Information furnished by Intersil is believed to be accurate and reliable. However, no responsibility is assumed by Intersil or its subsidiaries for its use; nor for any infringements of patents or other rights of third parties which may result from its use. No license is granted by implication or otherwise under any patent or patent rights of Intersil or its subsidiaries.*

For information regarding Intersil Corporation and its products, see web site <http://www.intersil.com>

### **Sales Office Headquarters**

#### **NORTH AMERICA**

Intersil Corporation  
P. O. Box 883, Mail Stop 53-204  
Melbourne, FL 32902  
TEL: (407) 724-7000  
FAX: (407) 724-7240

#### **EUROPE**

Intersil SA  
Mercure Center  
100, Rue de la Fusee  
1130 Brussels, Belgium  
TEL: (32) 2.724.2111  
FAX: (32) 2.724.22.05

#### **ASIA**

Intersil (Taiwan) Ltd.  
7F-6, No. 101 Fu Hsing North Road  
Taipei, Taiwan  
Republic of China  
TEL: (886) 2 2716 9310  
FAX: (886) 2 2715 3029