

100MHz Current Feedback Amplifier with DC Gain Control

FEATURES

- Very Fast Transconductance Amplifier
 - Bandwidth: 75MHz
 - $g_m = 10 \times I_{SET}$
 - Low THD: 0.2% at 30mV_{RMS} Input
 - Wide I_{SET} Range: 1 μ A to 1mA
- Very Fast Current Feedback Amplifier
 - Bandwidth: 100MHz
 - Slew Rate: 1000V/ μ s
 - Output Drive Current: 30mA
 - Differential Gain: 0.04%
 - Differential Phase: 0.1°
 - High Input Impedance: 25M Ω , 6pF
- Wide Supply Range: $\pm 2V$ to $\pm 15V$
- Inputs Common Mode to Within 1.5V of Supplies
- Outputs Swing Within 0.8V of Supplies
- Supply Current: 7mA

APPLICATIONS

- Video DC Restore (Clamp) Circuits
- Video Differential Input Amplifiers
- Video Keyer/Fader Amplifiers
- AGC Amplifiers
- Tunable Filters
- Oscillators

DESCRIPTION

The LT1228 makes it easy to electronically control the gain of signals from DC to video frequencies. The LT1228 implements gain control with a transconductance amplifier (voltage to current) whose gain is proportional to an externally controlled current. A resistor is typically used to convert the output current to a voltage, which is then amplified with a current feedback amplifier. The LT1228 combines both amplifiers into an 8-pin package, and operates on any supply voltage from 4V ($\pm 2V$) to 30V ($\pm 15V$). A complete differential input, gain controlled amplifier can be implemented with the LT1228 and just a few resistors.

The LT1228 transconductance amplifier has a high impedance differential input and a current source output with wide output voltage compliance. The transconductance, g_m , is set by the current that flows into pin 5, I_{SET} . The small signal g_m is equal to ten times the value of I_{SET} and this relationship holds over several decades of set current. The voltage at pin 5 is two diode drops above the negative supply, pin 4.

The LT1228 current feedback amplifier has very high input impedance and therefore it is an excellent buffer for the output of the transconductance amplifier. The current feedback amplifier maintains its wide bandwidth over a wide range of voltage gains making it easy to interface the transconductance amplifier output to other circuitry. The current feedback amplifier is designed to drive low impedance loads, such as cables, with excellent linearity at high frequencies.

TYPICAL APPLICATION

Differential Input Variable Gain Amp

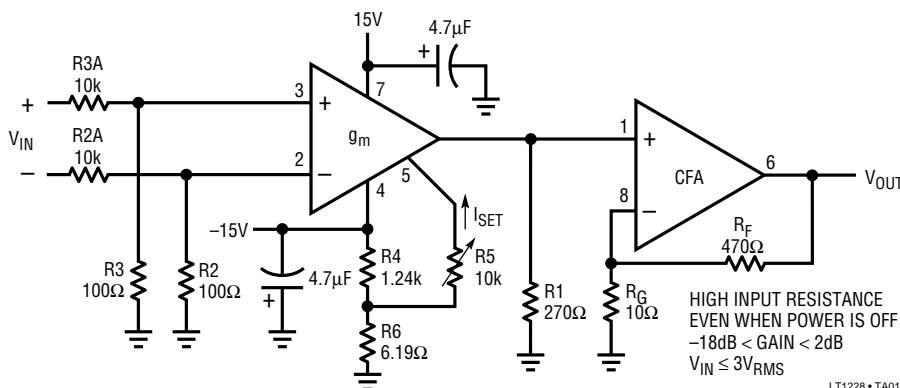

LT1228 • TA01

Frequency Response

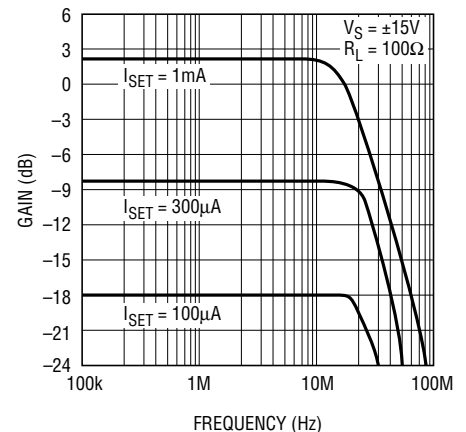

LT1228 • TA02

ABSOLUTE MAXIMUM RATINGS

Supply Voltage	±18V
Input Current, Pins 1, 2, 3, 5, 8 (Note 7)	±15mA
Output Short Circuit Duration (Note 1)	Continuous
Operating Temperature Range	
LT1228C	0°C to 70°C
LT1228M	-55°C to 125°C
Storage Temperature Range	-65°C to 150°C
Junction Temperature	
Plastic Package	150°C
Ceramic Package	175°C
Lead Temperature (Soldering, 10 sec).....	300°C

PACKAGE/ORDER INFORMATION

J8 PACKAGE N8 PACKAGE
8-LEAD CERAMIC DIP 8-LEAD PLASTIC DIP

S8 PACKAGE
8-LEAD PLASTIC SOIC

$T_{J\text{ MAX}} = 175^{\circ}\text{C}$, $\theta_{JA} = 100^{\circ}\text{C/W}$ (J)
 $T_{J\text{ MAX}} = 150^{\circ}\text{C}$, $\theta_{JA} = 100^{\circ}\text{C/W}$ (N)
 $T_{J\text{ MAX}} = 150^{\circ}\text{C}$, $\theta_{JA} = 150^{\circ}\text{C/W}$ (S)

ORDER PART NUMBER

LT1228MJ8
LT1228CJ8
LT1228CN8
LT1228CS8

S8 PART MARKING

1228

Consult Factory for Industrial grade parts.

ELECTRICAL CHARACTERISTICS

Current Feedback Amplifier, Pins 1, 6, 8. $\pm 5\text{V} \leq V_S \leq \pm 15\text{V}$, $I_{SET} = 0\mu\text{A}$, $V_{CM} = 0\text{V}$ unless otherwise noted.

SYMBOL	PARAMETER	CONDITIONS	MIN	TYP	MAX	UNITS	
V_{OS}	Input Offset Voltage	$T_A = 25^{\circ}\text{C}$	●	±3	±10	mV	
	Input Offset Voltage Drift		●	10	±15	$\mu\text{V}/^{\circ}\text{C}$	
I_{IN}^{+}	Noninverting Input Current	$T_A = 25^{\circ}\text{C}$	●	±0.3	±3	μA	
I_{IN}^{-}	Inverting Input Current	$T_A = 25^{\circ}\text{C}$	●	±10	±65	μA	
e_n	Input Noise Voltage Density	$f = 1\text{kHz}$, $R_F = 1\text{k}$, $R_G = 10\Omega$, $R_S = 0\Omega$		6		$\text{nV}/\sqrt{\text{Hz}}$	
i_n	Input Noise Current Density	$f = 1\text{kHz}$, $R_F = 1\text{k}$, $R_G = 10\Omega$, $R_S = 10\text{k}$		1.4		$\text{pV}/\sqrt{\text{Hz}}$	
R_{IN}	Input Resistance	$V_{IN} = \pm 13\text{V}$, $V_S = \pm 15\text{V}$	●	2	25	M Ω	
		$V_{IN} = \pm 3\text{V}$, $V_S = \pm 5\text{V}$	●	2	25	M Ω	
C_{IN}	Input Capacitance (Note 2)	$V_S = \pm 5\text{V}$		6		pF	
		Input Voltage Range	$V_S = \pm 15\text{V}$, $T_A = 25^{\circ}\text{C}$	●	±13	±13.5	V
				●	±12		V
			$V_S = \pm 5\text{V}$, $T_A = 25^{\circ}\text{C}$	●	±3	±3.5	V
		●	±2		V		
CMRR	Common-Mode Rejection Ratio	$V_S = \pm 15\text{V}$, $V_{CM} = \pm 13\text{V}$, $T_A = 25^{\circ}\text{C}$	●	55	69	dB	
		$V_S = \pm 15\text{V}$, $V_{CM} = \pm 12\text{V}$	●	55		dB	
		$V_S = \pm 5\text{V}$, $V_{CM} = \pm 3\text{V}$, $T_A = 25^{\circ}\text{C}$	●	55	69	dB	
		$V_S = \pm 5\text{V}$, $V_{CM} = \pm 2\text{V}$	●	55		dB	
PSRR	Power Supply Rejection Ratio	$V_S = \pm 15\text{V}$, $V_{CM} = \pm 13\text{V}$, $T_A = 25^{\circ}\text{C}$	●	2.5	10	$\mu\text{A/V}$	
		$V_S = \pm 15\text{V}$, $V_{CM} = \pm 12\text{V}$	●		10	$\mu\text{A/V}$	
		$V_S = \pm 5\text{V}$, $V_{CM} = \pm 3\text{V}$, $T_A = 25^{\circ}\text{C}$	●	2.5	10	$\mu\text{A/V}$	
		$V_S = \pm 5\text{V}$, $V_{CM} = \pm 2\text{V}$	●		10	$\mu\text{A/V}$	
	Noninverting Input Current Power Supply Rejection	$V_S = \pm 2\text{V}$ to $\pm 15\text{V}$, $T_A = 25^{\circ}\text{C}$	●	10	50	nA/V	
		$V_S = \pm 3\text{V}$ to $\pm 15\text{V}$	●		50	nA/V	
	Inverting Input Current Power Supply Rejection	$V_S = \pm 2\text{V}$ to $\pm 15\text{V}$, $T_A = 25^{\circ}\text{C}$	●	0.1	5	$\mu\text{A/V}$	
		$V_S = \pm 3\text{V}$ to $\pm 15\text{V}$	●		5	$\mu\text{A/V}$	

ELECTRICAL CHARACTERISTICS

Current Feedback Amplifier, Pins 1, 6, 8. $\pm 5V \leq V_S \leq \pm 15V$, $I_{SET} = 0\mu A$, $V_{CM} = 0V$ unless otherwise noted.

SYMBOL	PARAMETER	CONDITIONS	MIN	TYP	MAX	UNITS
A _V	Large-Signal Voltage Gain	V _S = ±15V, V _{OUT} = ±10V, R _{LOAD} = 1k	●	55	65	dB
		V _S = ±5V, V _{OUT} = ±2V, R _{LOAD} = 150Ω	●	55	65	dB
R _{OL}	Transresistance, ΔV _{OUT} /ΔI _{IN} ⁻	V _S = ±15V, V _{OUT} = ±10V, R _{LOAD} = 1k	●	100	200	kΩ
		V _S = ±5V, V _{OUT} = ±2V, R _{LOAD} = 150Ω	●	100	200	kΩ
V _{OUT}	Maximum Output Voltage Swing	V _S = ±15V, R _{LOAD} = 400Ω, T _A = 25°C	●	±12	±13.5	V
			●	±10		V
		V _S = ±5V, R _{LOAD} = 150Ω, T _A = 25°C	●	±3	±3.7	V
			●	±2.5		V
I _{OUT}	Maximum Output Current	R _{LOAD} = 0Ω, T _A = 25°C	●	30	65	mA
			●	25	125	mA
I _S	Supply Current	V _{OUT} = 0V, I _{SET} = 0V	●	6	11	mA
SR	Slew Rate (Notes 3 and 5)	T _A = 25°C		300	500	V/μs
SR	Slew Rate	V _S = ±15V, R _F = 750Ω, R _G = 750Ω, R _L = 400Ω		3500		V/μs
t _r	Rise Time (Notes 4 and 5)	T _A = 25°C		10	20	ns
BW	Small-Signal Bandwidth	V _S = ±15V, R _F = 750Ω, R _G = 750Ω, R _L = 100Ω		100		MHz
t _r	Small-Signal Rise Time	V _S = ±15V, R _F = 750Ω, R _G = 750Ω, R _L = 100Ω		3.5		ns
	Propagation Delay	V _S = ±15V, R _F = 750Ω, R _G = 750Ω, R _L = 100Ω		3.5		ns
	Small-Signal Overshoot	V _S = ±15V, R _F = 750Ω, R _G = 750Ω, R _L = 100Ω		15		%
	Settling Time	0.1%, V _{OUT} = 10V, R _F = 1k, R _G = 1k, R _L = 1k		45		ns
t _s	Differential Gain (Note 6)	V _S = ±15V, R _F = 750Ω, R _G = 750Ω, R _L = 1k		0.01		%
	Differential Phase (Note 6)	V _S = ±15V, R _F = 750Ω, R _G = 750Ω, R _L = 1k		0.01		DEG
	Differential Gain (Note 6)	V _S = ±15V, R _F = 750Ω, R _G = 750Ω, R _L = 150Ω		0.04		%
	Differential Phase (Note 6)	V _S = ±15V, R _F = 750Ω, R _G = 750Ω, R _L = 150Ω		0.1		DEG

ELECTRICAL CHARACTERISTICS

Transconductance Amplifier, Pins 1, 2, 3, 5. $\pm 5V \leq V_S \leq \pm 15V$, $I_{SET} = 100\mu A$, $V_{CM} = 0V$ unless otherwise noted.

SYMBOL	PARAMETER	CONDITIONS	MIN	TYP	MAX	UNITS
V _{OS}	Input Offset Voltage	I _{SET} = 1mA, T _A = 25°C	●	±0.5	±5	mV
	Input Offset Voltage Drift		●	10	±10	μV/°C
I _{OS}	Input Offset Current	T _A = 25°C	●	40	200	nA
			●		500	nA
I _B	Input Bias Current	T _A = 25°C	●	0.4	1	μA
			●		5	μA
e _n	Input Noise Voltage Density	f = 1kHz		20		nV/√Hz
R _{IN}	Input Resistance-Differential Mode	V _{IN} ≈ ±30mV	●	30	200	kΩ
	Input Resistance-Common Mode	V _S = ±15V, V _{CM} = ±12V	●	50	1000	MΩ
		V _S = ±5V, V _{CM} = ±2V	●	50	1000	MΩ
C _{IN}	Input Capacitance			3		pF
	Input Voltage Range	V _S = ±15V, T _A = 25°C	●	±13	±14	V
		V _S = ±15V	●	±12		V
		V _S = ±5V, T _A = 25°C	●	±3	±4	V
		V _S = ±5V	●	±2		V

ELECTRICAL CHARACTERISTICS

Transconductance Amplifier, Pins 1, 2, 3, 5. $\pm 5V \leq V_S \leq \pm 15V$, $I_{SET} = 100\mu A$, $V_{CM} = 0V$ unless otherwise noted.

SYMBOL	PARAMETER	CONDITIONS	MIN	TYP	MAX	UNITS	
CMRR	Common-Mode Rejection Ratio	$V_S = \pm 15V$, $V_{CM} = \pm 13V$, $T_A = 25^\circ C$		60	100		dB
		$V_S = \pm 15V$, $V_{CM} = \pm 12V$	●	60			dB
		$V_S = \pm 5V$, $V_{CM} = \pm 3V$, $T_A = 25^\circ C$		60	100		dB
		$V_S = \pm 5V$, $V_{CM} = \pm 2V$	●	60			dB
PSRR	Power Supply Rejection Ratio	$V_S = \pm 2V$ to $\pm 15V$, $T_A = 25^\circ C$		60	100		dB
		$V_S = \pm 3V$ to $\pm 15V$	●	60			dB
g_m	Transconductance	$I_{SET} = 100\mu A$, $I_{OUT} = \pm 30\mu A$, $T_A = 25^\circ C$		0.75	1.00	1.25	$\mu A/mV$
	Transconductance Drift		●	-0.33			$\%/^\circ C$
I_{OUT}	Maximum Output Current	$I_{SET} = 100\mu A$	●	70	100	130	μA
I_{OL}	Output Leakage Current	$I_{SET} = 0\mu A$ ($+I_{IN}$ of CFA), $T_A = 25^\circ C$			0.3	3	μA
			●			10	μA
V_{OUT}	Maximum Output Voltage Swing	$V_S = \pm 15V$, $R_1 = \infty$	●	± 13	± 14		V
		$V_S = \pm 5V$, $R_1 = \infty$	●	± 3	± 4		V
R_O	Output Resistance	$V_S = \pm 15V$, $V_{OUT} = \pm 13V$	●	2	8		$M\Omega$
		$V_S = \pm 5V$, $V_{OUT} = \pm 3V$	●	2	8		$M\Omega$
	Output Capacitance (Note 2)	$V_S = \pm 5V$			6		pF
I_S	Supply Current, Both Amps	$I_{SET} = 1mA$	●		9	15	mA
THD	Total Harmonic Distortion	$V_{IN} = 30mV_{RMS}$ at 1kHz, $R_1 = 100k$			0.2		%
BW	Small-Signal Bandwidth	$R_1 = 50\Omega$, $I_{SET} = 500\mu A$			80		MHz
t_r	Small-Signal Rise Time	$R_1 = 50\Omega$, $I_{SET} = 500\mu A$, 10% to 90%			5		ns
	Propagation Delay	$R_1 = 50\Omega$, $I_{SET} = 500\mu A$, 50% to 50%			5		ns

The ● denotes specifications which apply over the operating temperature range.

Note 1: A heat sink may be required depending on the power supply voltage.

Note 2: This is the total capacitance at pin 1. It includes the input capacitance of the current feedback amplifier and the output capacitance of the transconductance amplifier.

Note 3: Slew rate is measured at $\pm 5V$ on a $\pm 10V$ output signal while operating on $\pm 15V$ supplies with $R_F = 1k$, $R_G = 110\Omega$ and $R_L = 400\Omega$. The slew rate is much higher when the input is overdriven, see the applications section.

Note 4: Rise time is measured from 10% to 90% on a $\pm 500mV$ output signal while operating on $\pm 15V$ supplies with $R_F = 1k$, $R_G = 110\Omega$ and $R_L = 100\Omega$. This condition is not the fastest possible, however, it does guarantee the internal capacitances are correct and it makes automatic testing practical.

Note 5: AC parameters are 100% tested on the ceramic and plastic DIP packaged parts (J and N suffix) and are sample tested on every lot of the SO packaged parts (S suffix).

Note 6: NTSC composite video with an output level of 2V.

Note 7: Back to back 6V Zener diodes are connected between pins 2 and 3 for ESD protection.

TYPICAL PERFORMANCE CHARACTERISTICS Transconductance Amplifier, Pins 1, 2, 3 & 5

Small-Signal Bandwidth vs Set Current

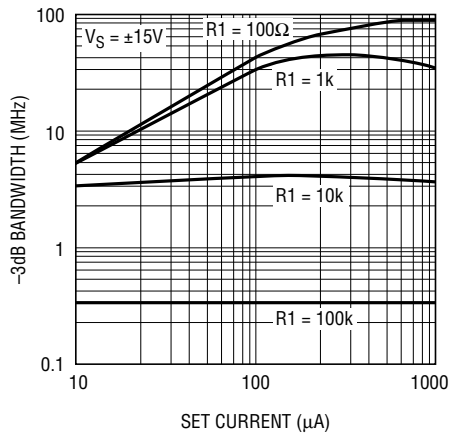

LT1228 • TPC01

Small-Signal Transconductance and Set Current vs Bias Voltage

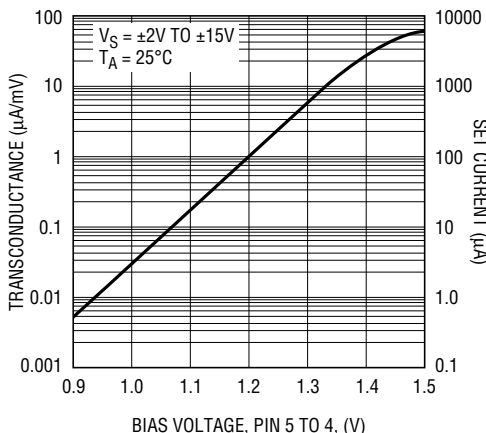

LT1228 • TPC02

Small-Signal Transconductance vs DC Input Voltage

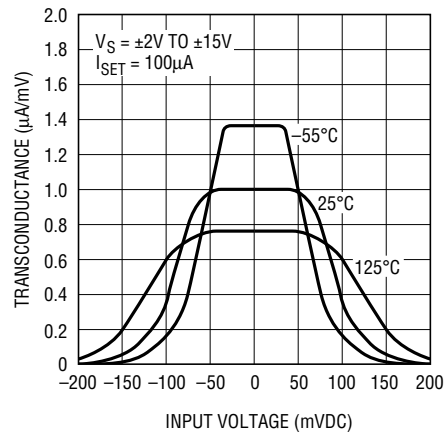

LT1228 • TPC03

Total Harmonic Distortion vs Input Voltage

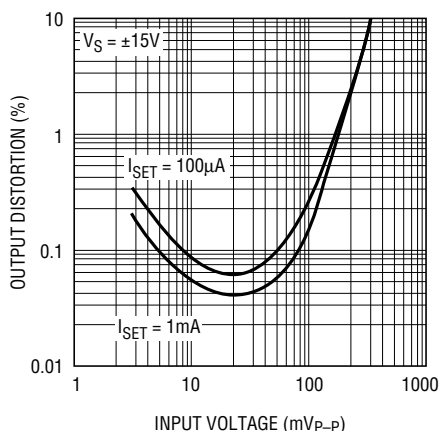

LT1228 • TPC04

Spot Output Noise Current vs Frequency

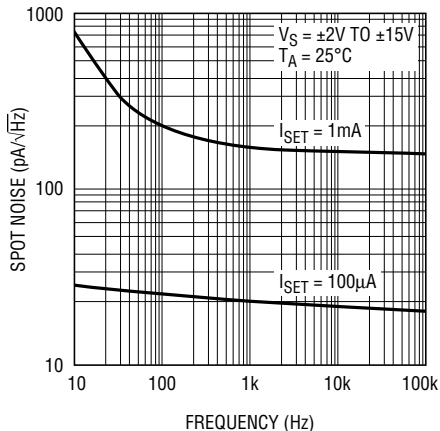

LT1228 • TPC05

Input Common-Mode Limit vs Temperature

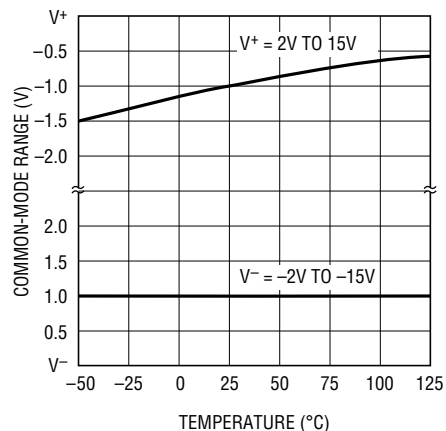

LT1228 • TPC06

Small-Signal Control Path Bandwidth vs Set Current

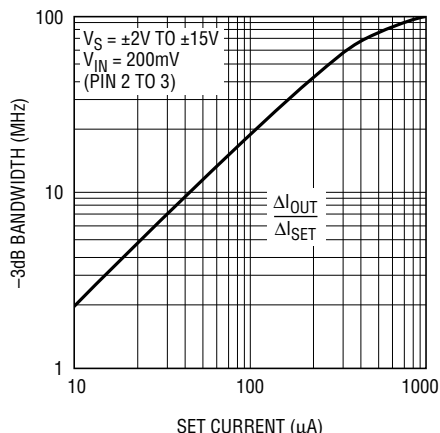

LT1228 • TPC07

Small-Signal Control Path Gain vs Input Voltage

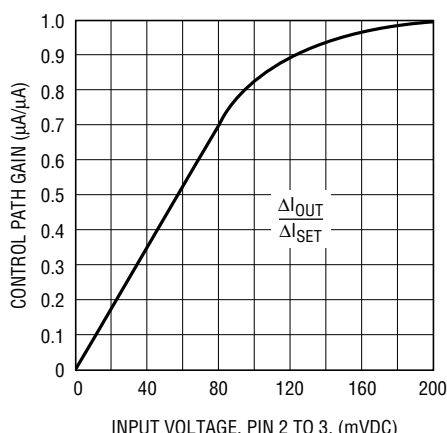

LT1228 • TPC08

Output Saturation Voltage vs Temperature

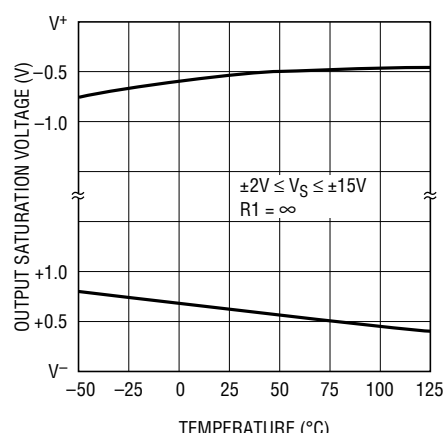

LT1228 • TPC09

TYPICAL PERFORMANCE CHARACTERISTICS Current Feedback Amplifier, Pins 1, 6, 8

Voltage Gain and Phase vs Frequency, Gain = 6dB

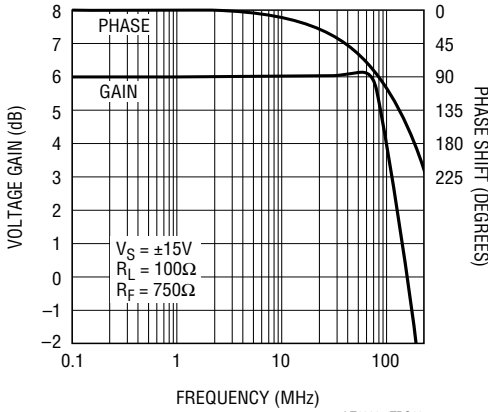

-3dB Bandwidth vs Supply Voltage, Gain = 2, RL = 100Ω

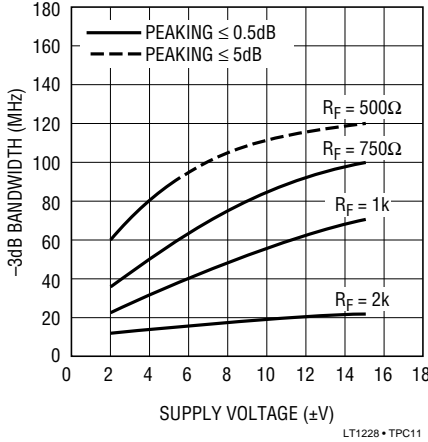

-3dB Bandwidth vs Supply Voltage, Gain = 2, RL = 1k

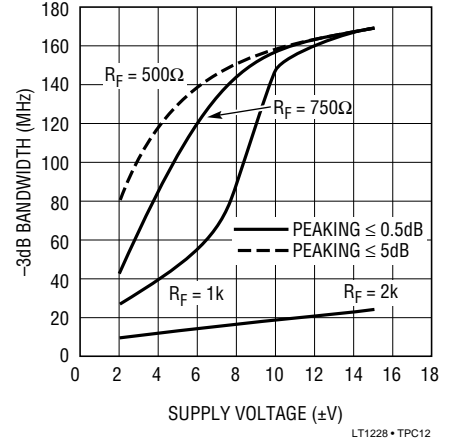

Voltage Gain and Phase vs Frequency, Gain = 20dB

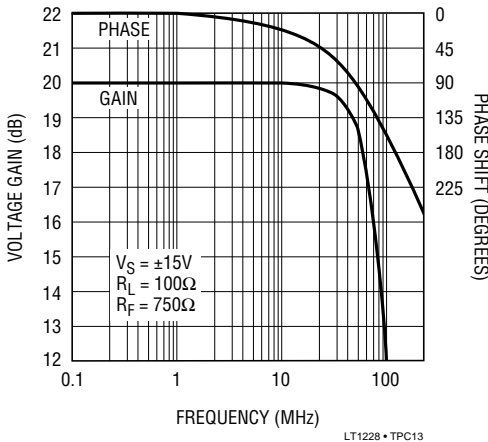

-3dB Bandwidth vs Supply Voltage, Gain = 10, RL = 100Ω

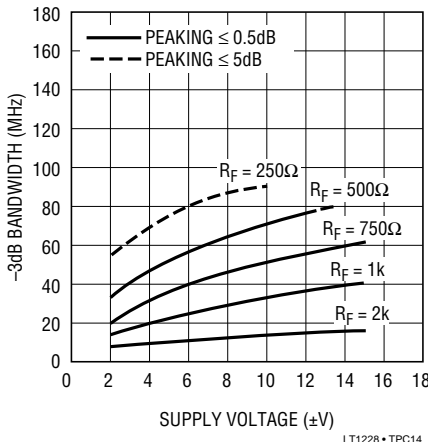

-3dB Bandwidth vs Supply Voltage, Gain = 10, RL = 1kΩ

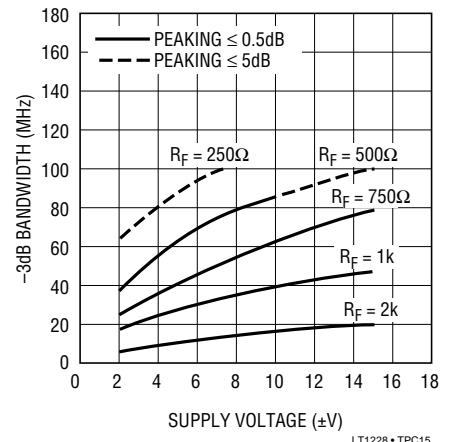

Voltage Gain and Phase vs Frequency, Gain = 40dB

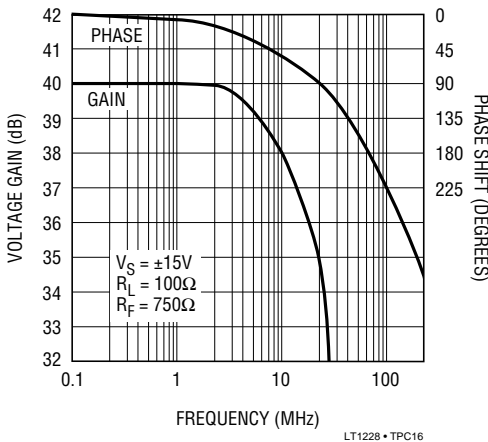

-3dB Bandwidth vs Supply Voltage, Gain = 100, RL = 100Ω

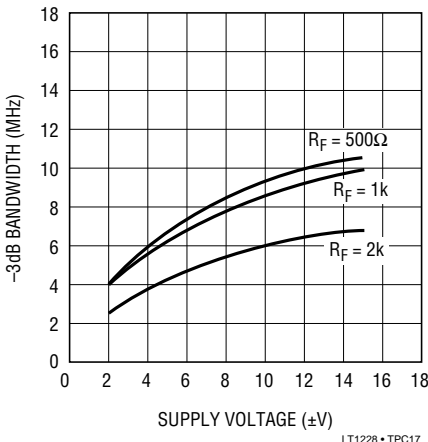

-3dB Bandwidth vs Supply Voltage, Gain = 100, RL = 1kΩ

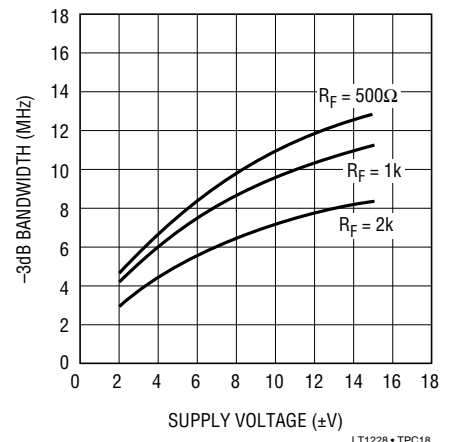

TYPICAL PERFORMANCE CHARACTERISTICS Current Feedback Amplifier, Pins 1, 6, 8

Maximum Capacitive Load vs Feedback Resistor

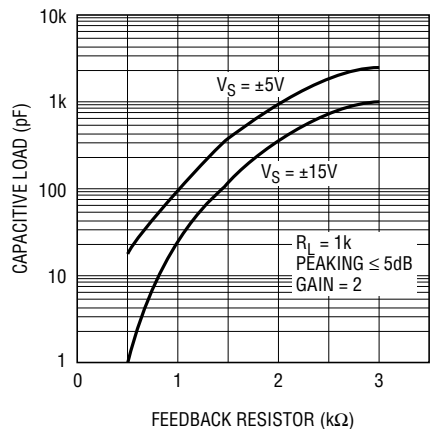

LT1228 • TPC19

Total Harmonic Distortion vs Frequency

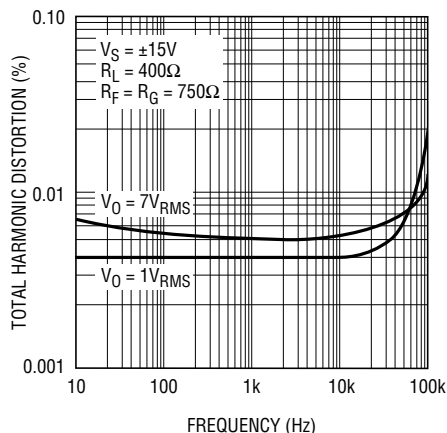

LT1228 • TPC20

2nd and 3rd Harmonic Distortion vs Frequency

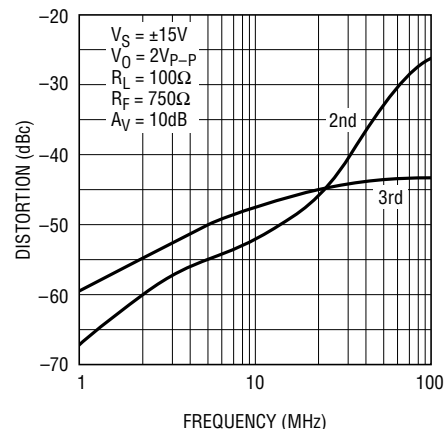

LT1228 • TPC21

Input Common-Mode Limit vs Temperature

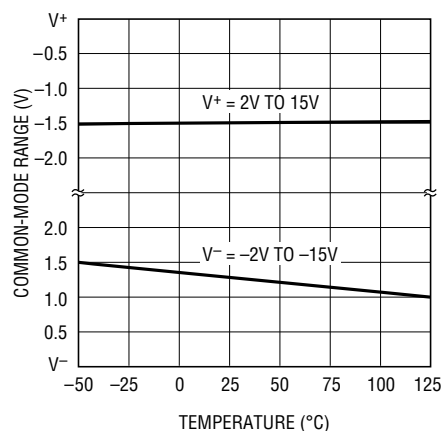

LT1228 • TPC22

Output Saturation Voltage vs Temperature

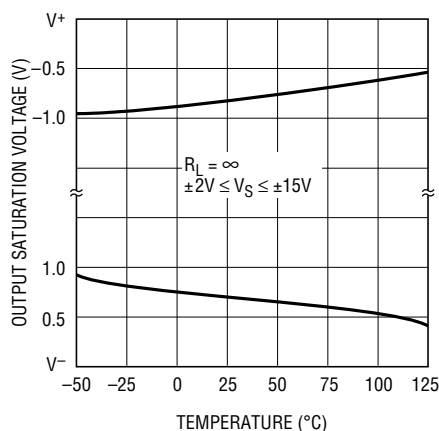

LT1228 • TPC23

Output Short-Circuit Current vs Temperature

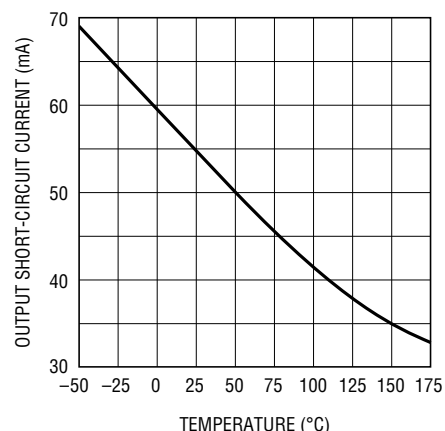

LT1228 • TPC24

Spot Noise Voltage and Current vs Frequency

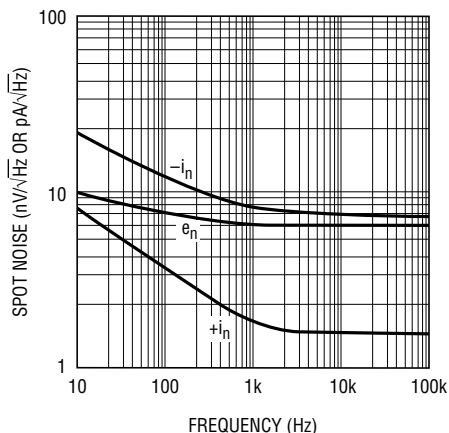

LT1228 • TPC25

Power Supply Rejection vs Frequency

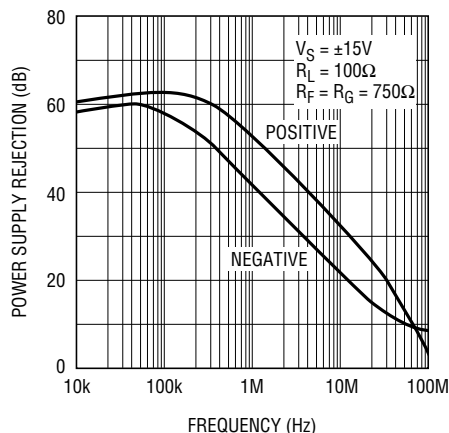

LT1228 • TPC26

Output Impedance vs Frequency

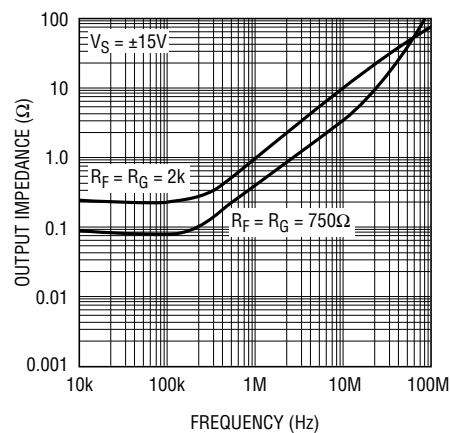

LT1228 • TPC27

TYPICAL PERFORMANCE CHARACTERISTICS Current Feedback Amplifier, Pins 1, 6 & 8

Settling Time to 10mV vs Output Step

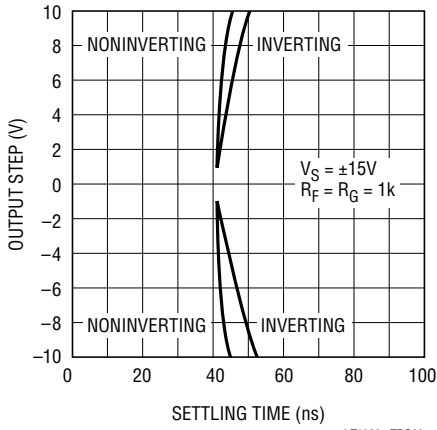

LT1228 • TPC28

Settling Time to 1mV vs Output Step

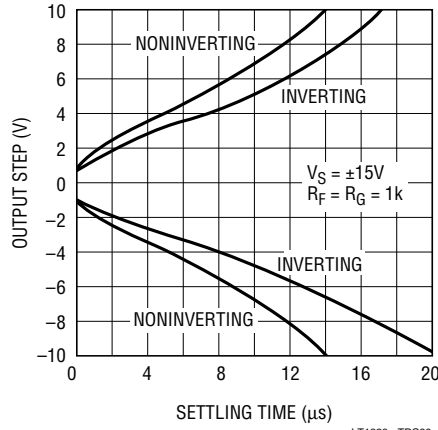

LT1228 • TPC29

Supply Current vs Supply Voltage

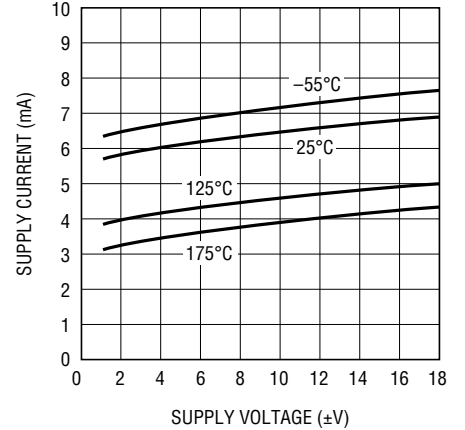

LT1228 • TPC30

SIMPLIFIED SCHEMATIC

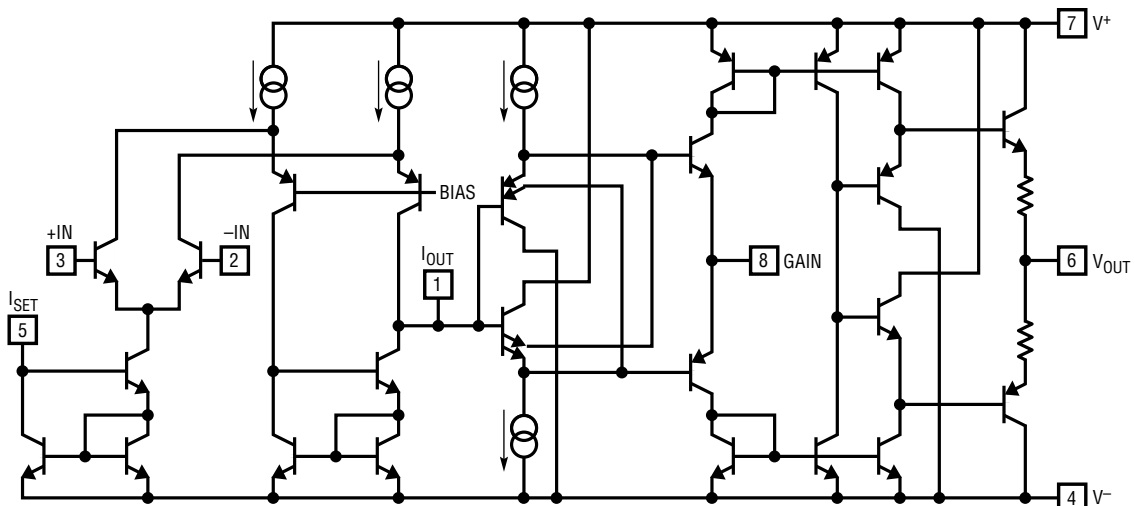

LT1228 • TA03

APPLICATIONS INFORMATION

The LT1228 contains two amplifiers, a transconductance amplifier (voltage-to-current) and a current feedback amplifier (voltage-to-voltage). The gain of the transconductance amplifier is proportional to the current that is externally programmed into pin 5. Both amplifiers are designed to operate on almost any available supply voltage from 4V ($\pm 2V$) to 30V ($\pm 15V$). The output of the transconductance amplifier is connected to the noninverting input of the current feedback amplifier so that both fit into an eight pin package.

TRANSCONDUCTANCE AMPLIFIER

The LT1228 transconductance amplifier has a high impedance differential input (pins 2 and 3) and a current source output (pin 1) with wide output voltage compliance. The voltage to current gain or transconductance (g_m) is set by the current that flows into pin 5, I_{SET} . The voltage at pin 5 is two forward biased diode drops above the negative supply, pin 4. Therefore the voltage at pin 5 (with respect to V^-) is about 1.2V and changes with the log of the set current (120mV/decade), see the characteristic curves. The temperature coefficient of this voltage is about $-4mV/^\circ C$ ($-3300ppm/^\circ C$) and the temperature coefficient of the logging characteristic is $3300ppm/^\circ C$. It is important that the current into pin 5 be limited to less than 15mA. THE LT1228 WILL BE DESTROYED IF PIN 5 IS SHORTED TO GROUND OR TO THE POSITIVE SUPPLY. A limiting resistor (2k or so) should be used to prevent more than 15mA from flowing into pin 5.

The small-signal transconductance (g_m) is equal to ten times the value of I_{SET} (in mA/mV) and this relationship holds over many decades of set current (see the characteristic curves). The transconductance is inversely proportional to absolute temperature ($-3300ppm/^\circ C$). The input stage of the transconductance amplifier has been designed to operate with much larger signals than is possible with an ordinary diff-amp. The transconductance of the input stage varies much less than 1% for differential input signals over a ± 30 mV range (see the characteristic curve Small-Signal Transconductance vs DC Input Voltage).

Resistance Controlled Gain

If the set current is to be set or varied with a resistor or potentiometer it is possible to use the negative temperature coefficient at pin 5 (with respect to pin 4) to compensate for the negative temperature coefficient of the transconductance. The easiest way is to use an LT1004-2.5, a 2.5V reference diode, as shown below:

Temperature Compensation of g_m with a 2.5V Reference

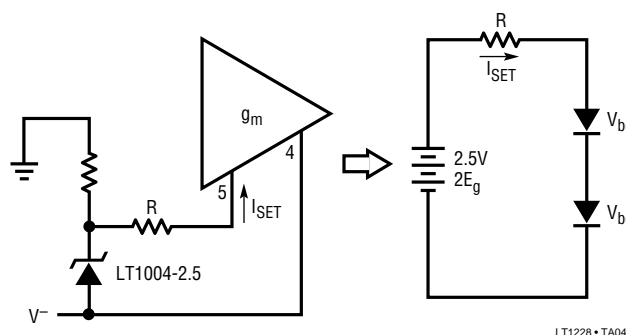

The current flowing into pin 5 has a positive temperature coefficient that cancels the negative coefficient of the transconductance. The following derivation shows why a 2.5V reference results in zero gain change with temperature:

$$\text{Since } g_m = \frac{q}{kT} \times \frac{I_{SET}}{3.87} = 10 \times I_{SET}$$

$$\text{and } V_{be} = E_g - \frac{akT}{q} \text{ where } a = \ln\left(\frac{cT^n}{I_c}\right) \approx 19.4 \text{ at } 27^\circ C$$

$$(c = 0.001, n = 3, I_c = 100\mu A)$$

E_g is about 1.25V so the 2.5V reference is $2E_g$. Solving the loop for the set current gives:

$$I_{SET} = \frac{2E_g - 2\left(E_g - \frac{akT}{q}\right)}{R} \text{ or } I_{SET} = \frac{2akT}{Rq}$$

APPLICATIONS INFORMATION

Substituting into the equation for transconductance gives:

$$g_m = \frac{a}{1.94R} = \frac{10}{R}$$

The temperature variation in the term “a” can be ignored since it is much less than that of the term “T” in the equation for V_{be} . Using a 2.5V source this way will maintain the gain constant within 1% over the full temperature range of -55°C to 125°C . If the 2.5V source is off by 10%, the gain will vary only about $\pm 6\%$ over the same temperature range.

We can also temperature compensate the transconductance without using a 2.5V reference if the negative power supply is regulated. A Thevenin equivalent of 2.5V is generated from two resistors to replace the reference. The two resistors also determine the maximum set current, approximately $1.1\text{V}/R_{TH}$. By rearranging the Thevenin equations to solve for R4 and R6 we get the following equations in terms of R_{TH} and the negative supply, V_{EE} .

$$R4 = \frac{R_{TH}}{\left(1 - \frac{2.5\text{V}}{V_{EE}}\right)} \text{ and } R6 = \frac{R_{TH}V_{EE}}{2.5\text{V}}$$

Temperature Compensation of g_m with a Thevenin Voltage

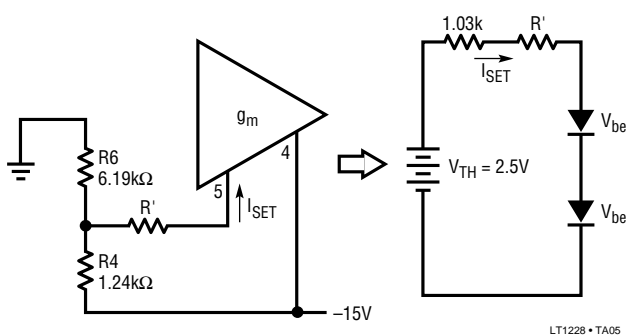

Voltage Controlled Gain

To use a voltage to control the gain of the transconductance amplifier requires converting the voltage into a current that flows into pin 5. Because the voltage at pin 5

is two diode drops above the negative supply, a single resistor from the control voltage source to pin 5 will suffice in many applications. The control voltage is referenced to the negative supply and has an offset of about 900mV. The conversion will be monotonic, but the linearity is determined by the change in the voltage at pin 5 (120mV per decade of current). The characteristic is very repeatable since the voltage at pin 5 will vary less than $\pm 5\%$ from part to part. The voltage at pin 5 also has a negative temperature coefficient as described in the previous section. When the gain of several LT1228s are to be varied together, the current can be split equally by using equal value resistors to each pin 5.

For more accurate (and linear) control, a voltage-to-current converter circuit using one op amp can be used. The following circuit has several advantages. The input no longer has to be referenced to the negative supply and the input can be either polarity (or differential). This circuit works on both single and split supplies since the input voltage and the pin 5 voltage are independent of each other. The temperature coefficient of the output current is set by R5.

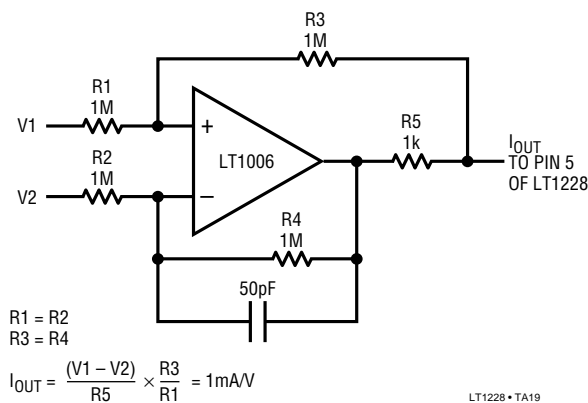

$$I_{OUT} = \frac{(V1 - V2)}{R5} \times \frac{R3}{R1} = 1\text{mA/V}$$

Digital control of the transconductance amplifier gain is done by converting the output of a DAC to a current flowing into pin 5. Unfortunately most current output DACs sink rather than source current and do not have output

APPLICATIONS INFORMATION

compliance compatible with pin 5 of the LT1228. Therefore, the easiest way to digitally control the set current is to use a voltage output DAC and a voltage-to-current circuit. The previous voltage-to-current converter will take the output of any voltage output DAC and drive pin 5 with a proportional current. The R, 2R CMOS multiplying DACs operating in the voltage switching mode work well on both single and split supplies with the above circuit.

Logarithmic control is often easier to use than linear control. A simple circuit that doubles the set current for each additional volt of input is shown in the voltage controlled state variable filter application near the end of this data sheet.

Transconductance Amplifier Frequency Response

The bandwidth of the transconductance amplifier is a function of the set current as shown in the characteristic curves. At set currents below $100\mu\text{A}$, the bandwidth is approximately:

$$-3\text{dB bandwidth} = 3 \times 10^{11} I_{\text{SET}}$$

The peak bandwidth is about 80MHz at $500\mu\text{A}$. When a resistor is used to convert the output current to a voltage, the capacitance at the output forms a pole with the resistor. The best case output capacitance is about 5pF with $\pm 15\text{V}$ supplies and 6pF with $\pm 5\text{V}$ supplies. You must add any PC board or socket capacitance to these values to get the total output capacitance. When using a 1k resistor at the output of the transconductance amp, the output capacitance limits the bandwidth to about 25MHz.

The output slew rate of the transconductance amplifier is the set current divided by the output capacitance, which is 6pF plus board and socket capacitance. For example with the set current at 1mA, the slew rate would be over $100\text{V}/\mu\text{s}$.

Transconductance Amp Small-Signal Response
 $I_{\text{SET}} = 500\mu\text{A}$, $R_1 = 50\Omega$

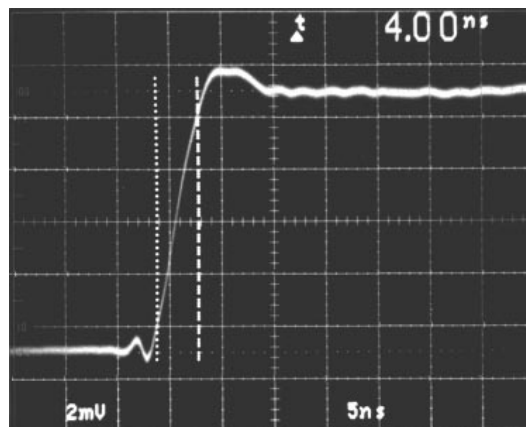

CURRENT FEEDBACK AMPLIFIER

The LT1228 current feedback amplifier has very high noninverting input impedance and is therefore an excellent buffer for the output of the transconductance amplifier. The noninverting input is at pin 1, the inverting input at pin 8 and the output at pin 6. The current feedback amplifier maintains its wide bandwidth for almost all voltage gains making it easy to interface the output levels of the transconductance amplifier to other circuitry. The current feedback amplifier is designed to drive low impedance loads such as cables with excellent linearity at high frequencies.

Feedback Resistor Selection

The small-signal bandwidth of the LT1228 current feedback amplifier is set by the external feedback resistors and the internal junction capacitors. As a result, the bandwidth is a function of the supply voltage, the value of the feedback resistor, the closed-loop gain and load resistor. The characteristic curves of bandwidth versus supply voltage are done with a heavy load (100Ω) and a light load (1k) to show the effect of loading. These graphs also show

APPLICATIONS INFORMATION

the family of curves that result from various values of the feedback resistor. These curves use a solid line when the response has less than 0.5dB of peaking and a dashed line for the response with 0.5dB to 5dB of peaking. The curves stop where the response has more than 5dB of peaking.

Current Feedback Amp Small-Signal Response
 $V_S = \pm 15V$, $R_F = R_G = 750\Omega$, $R_L = 100\Omega$

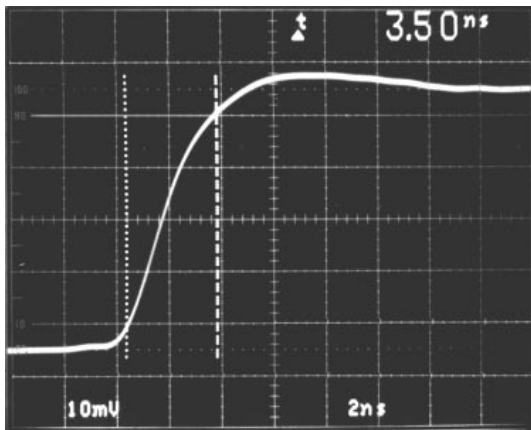

At a gain of two, on $\pm 15V$ supplies with a 750Ω feedback resistor, the bandwidth into a light load is over 160MHz without peaking, but into a heavy load the bandwidth reduces to 100MHz. The loading has so much effect because there is a mild resonance in the output stage that enhances the bandwidth at light loads but has its Q reduced by the heavy load. This enhancement is only useful at low gain settings, at a gain of ten it does not boost the bandwidth. At unity gain, the enhancement is so effective the value of the feedback resistor has very little effect on the bandwidth. At very high closed-loop gains, the bandwidth is limited by the gain-bandwidth product of about 1GHz. The curves show that the bandwidth at a closed-loop gain of 100 is 10MHz, only one tenth what it is at a gain of two.

Capacitance on the Inverting Input

Current feedback amplifiers want resistive feedback from the output to the inverting input for stable operation. Take care to minimize the stray capacitance between the output and the inverting input. Capacitance on the inverting input to ground will cause peaking in the frequency response (and overshoot in the transient response), but it does not degrade the stability of the amplifier. The amount of capacitance that is necessary to cause peaking is a function of the closed-loop gain taken. The higher the gain, the more capacitance is required to cause peaking. For example, in a gain of 100 application, the bandwidth can be increased from 10MHz to 17MHz by adding a 2200pF capacitor, as shown below. C_G must have very low series resistance, such as silver mica.

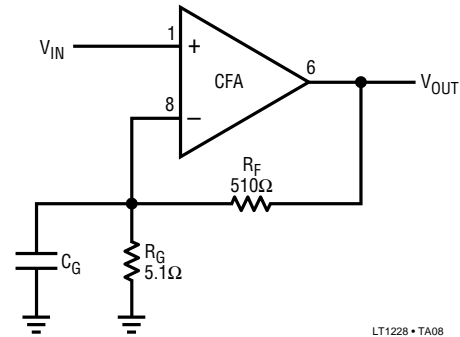

LT1228 • TA08

Boosting Bandwidth of High Gain Amplifier with Capacitance On Inverting Input

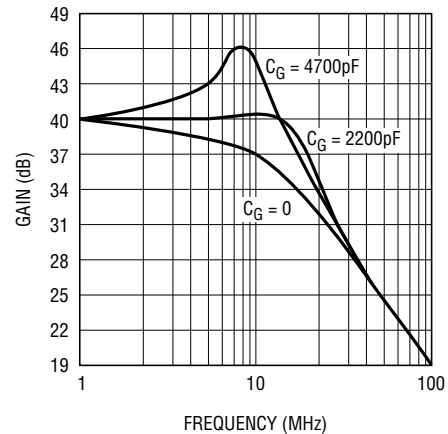

LT1228 • TA09

APPLICATIONS INFORMATION

Capacitive Loads

The LT1228 current feedback amplifier can drive capacitive loads directly when the proper value of feedback resistor is used. The graph of Maximum Capacitive Load vs Feedback Resistor should be used to select the appropriate value. The value shown is for 5dB peaking when driving a 1k load, at a gain of 2. This is a worst case condition, the amplifier is more stable at higher gains, and driving heavier loads. Alternatively, a small resistor (10Ω to 20Ω) can be put in series with the output to isolate the capacitive load from the amplifier output. This has the advantage that the amplifier bandwidth is only reduced when the capacitive load is present and the disadvantage that the gain is a function of the load resistance.

Slew Rate

The slew rate of the current feedback amplifier is not independent of the amplifier gain configuration the way it is in a traditional op amp. This is because the input stage and the output stage both have slew rate limitations. The input stage of the LT1228 current feedback amplifier slews at about 100V/μs before it becomes nonlinear. Faster input signals will turn on the normally reverse biased emitters on the input transistors and enhance the slew rate significantly. This enhanced slew rate can be as much as 3500V/μs!

Current Feedback Amp Large-Signal Response
 $V_S = \pm 15V$, $R_F = R_G = 750\Omega$ Slew Rate Enhanced

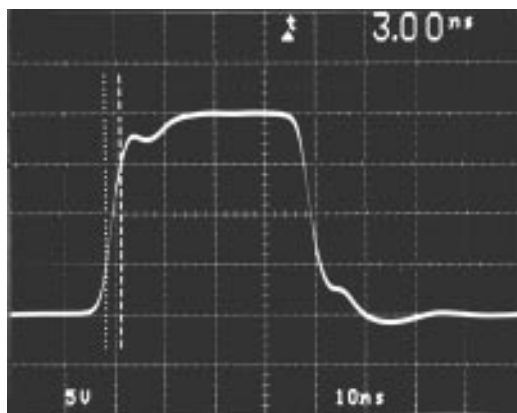

The output slew rate is set by the value of the feedback resistors and the internal capacitance. At a gain of ten with a 1k feedback resistor and ±15V supplies, the output slew rate is typically 500V/μs and -850V/μs. There is no input stage enhancement because of the high gain. Larger feedback resistors will reduce the slew rate as will lower supply voltages, similar to the way the bandwidth is reduced.

Current Feedback Amp Large-Signal Response
 $V_S = \pm 15V$, $R_F = 1k$, $R_G = 110\Omega$, $R_L = 400\Omega$

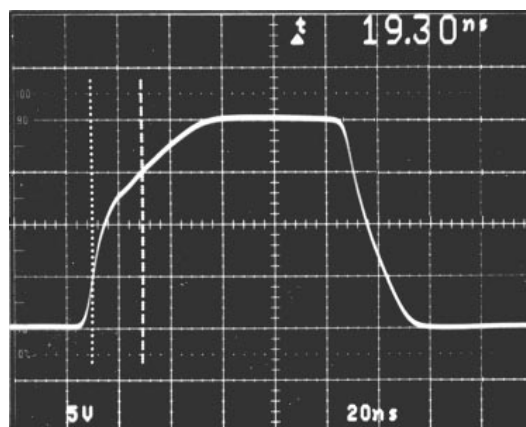

Settling Time

The characteristic curves show that the LT1228 current feedback amplifier settles to within 10mV of final value in 40ns to 55ns for any output step less than 10V. The curve of settling to 1mV of final value shows that there is a slower thermal contribution up to 20μs. The thermal settling component comes from the output and the input stage. The output contributes just under 1mV/V of output change and the input contributes 300μV/V of input change. Fortunately the input thermal tends to cancel the output thermal. For this reason the noninverting gain of two configuration settles faster than the inverting gain of one.

APPLICATIONS INFORMATION

Power Supplies

The LT1228 amplifiers will operate from single or split supplies from $\pm 2V$ (4V total) to $\pm 18V$ (36V total). It is not necessary to use equal value split supplies, however the offset voltage and inverting input bias current of the current feedback amplifier will degrade. The offset voltage changes about $350\mu V/V$ of supply mismatch, the inverting bias current changes about $2.5\mu A/V$ of supply mismatch.

Power Dissipation

The worst case amplifier power dissipation is the total of the quiescent current times the total power supply voltage plus the power in the IC due to the load. The quiescent supply current of the LT1228 transconductance amplifier is equal to 3.5 times the set current at all temperatures. The quiescent supply current of the LT1228 current feedback amplifier has a strong negative temperature coefficient and at $150^\circ C$ is less than 7mA, typically only 4.5mA. The power in the IC due to the load is a function of the output voltage, the supply voltage and load resistance. The worst case occurs when the output voltage is at half supply, if it can go that far, or its maximum value if it cannot reach half supply.

For example, let's calculate the worst case power dissipation in a variable gain video cable driver operating on $\pm 12V$ supplies that delivers a maximum of 2V into 150Ω . The maximum set current is 1mA.

$$P_D = 2V_S (I_{S\text{MAX}} + 3.5I_{\text{SET}}) + (V_S - V_{O\text{MAX}}) \frac{V_{O\text{MAX}}}{R_L}$$

$$P_D = 2 \times 12V \times [7\text{mA} + (3.5 \times 1\text{mA})] + (12V - 2V) \frac{2V}{150\Omega}$$

$$= 0.252 + 0.133 = 0.385W$$

The total power dissipation times the thermal resistance of the package gives the temperature rise of the die above ambient. The above example in SO-8 surface mount package (thermal resistance is $150^\circ C/W$) gives:

$$\text{Temperature Rise} = P_D \theta_{JA} = 0.385W \times 150^\circ C/W$$

$$= 57.75^\circ C$$

Therefore the maximum junction temperature is $70^\circ C + 57.75^\circ C$ or $127.75^\circ C$, well under the absolute maximum junction temperature for plastic packages of $150^\circ C$.

TYPICAL APPLICATIONS

Basic Gain Control

The basic gain controlled amplifier is shown on the front page of the data sheet. The gain is directly proportional to the set current. The signal passes through three stages from the input to the output.

First the input signal is attenuated to match the dynamic range of the transconductance amplifier. The attenuator should reduce the signal down to less than 100mV peak. The characteristic curves can be used to estimate how much distortion there will be at maximum input signal. For single ended inputs eliminate R2A or R3A.

The signal is then amplified by the transconductance amplifier (g_m) and referred to ground. The voltage gain of the transconductance amplifier is:

$$g_m \times R1 = 10 \times I_{\text{SET}} \times R1$$

Lastly the signal is buffered and amplified by the current feedback amplifier (CFA). The voltage gain of the current feedback amplifier is:

$$1 + \frac{R_F}{R_G}$$

The overall gain of the gain controlled amplifier is the product of all three stages:

$$A_V = \left(\frac{R3}{R3 + R3A} \right) \times 10 \times I_{\text{SET}} \times R1 \times \left(1 + \frac{R_F}{R_G} \right)$$

More than one output can be summed into R1 because the output of the transconductance amplifier is a current. This is the simplest way to make a video mixer.

TYPICAL APPLICATIONS

Video Fader

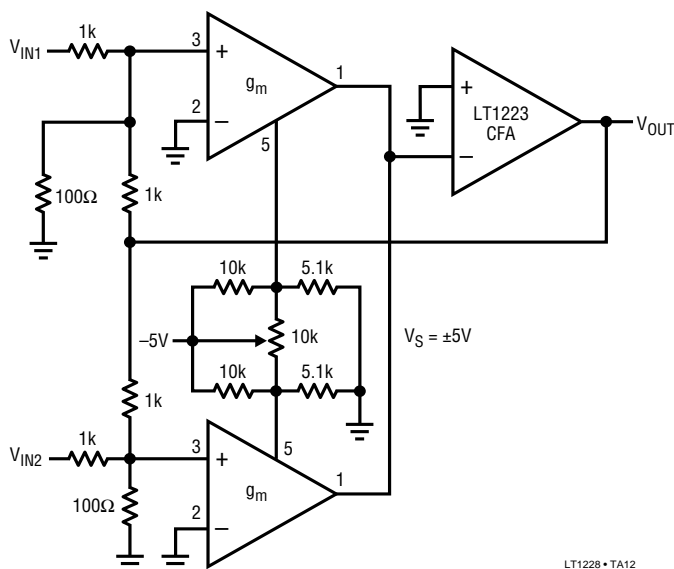

LT1228 • TA12

The video fader uses the transconductance amplifiers from two LT1228s in the feedback loop of another current feedback amplifier, the LT1223. The amount of signal from each input at the output is set by the ratio of the set currents of the two LT1228s, not by their absolute value. The bandwidth of the current feedback amplifier is inversely proportional to the set current in this configuration. Therefore, the set currents remain high over most of the pot's range, keeping the bandwidth over 15MHz even when the signal is attenuated 20dB. The pot is set up to completely turn off one LT1228 at each end of the rotation.

Video DC Restore (Clamp) Circuit

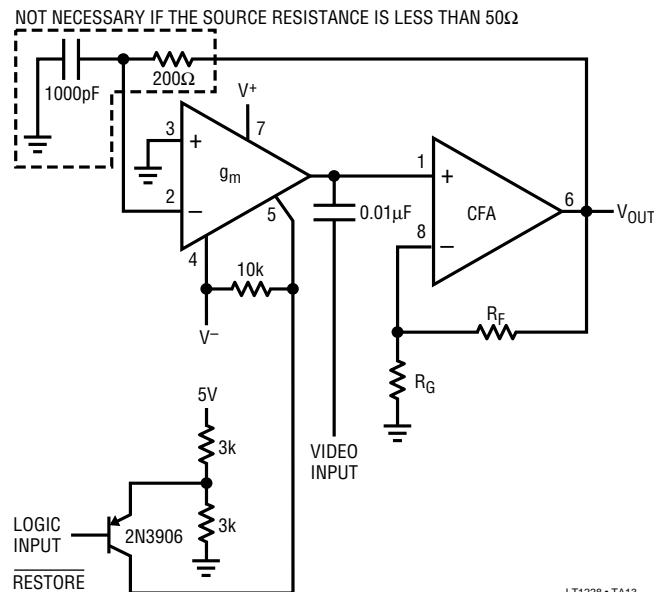

LT1228 • TA13

The video restore (clamp) circuit restores the black level of the composite video to zero volts at the beginning of every line. This is necessary because AC coupled video changes DC level as a function of the average brightness of the picture. DC restoration also rejects low frequency noise such as hum.

The circuit has two inputs: composite video and a logic signal. The logic signal is high except during the back porch time right after the horizontal sync pulse. While the logic is high, the PNP is off and I_{SET} is zero. With I_{SET} equal to zero the feedback to pin 2 has no affect. The video input drives the noninverting input of the current feedback amplifier whose gain is set by R_F and R_G . When the logic signal is low, the PNP turns on and I_{SET} goes to about 1mA. Then the transconductance amplifier charges the capacitor to force the output to match the voltage at pin 3, in this case zero volts.

This circuit can be modified so that the video is DC coupled by operating the amplifier in an inverting configuration. Just ground the video input shown and connect R_G to the video input instead of to ground.

TYPICAL APPLICATIONS

Single Supply Wien Bridge Oscillator

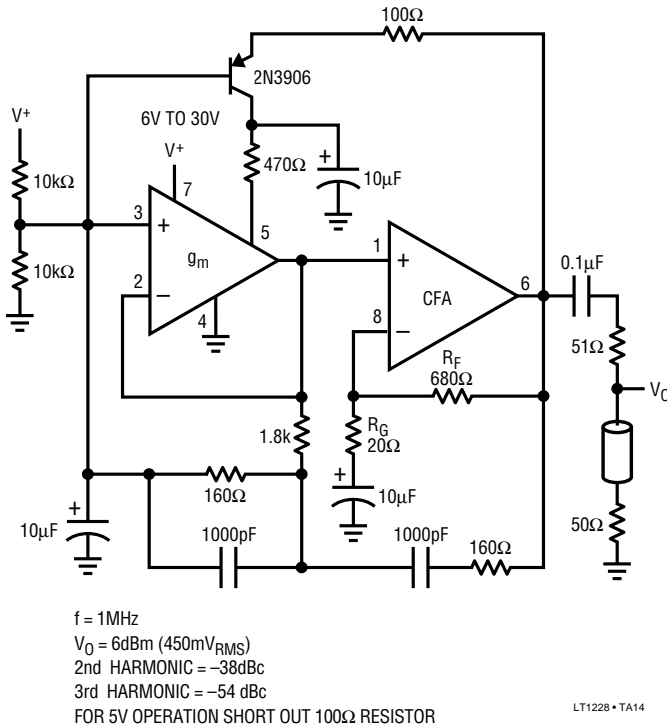

In this application the LT1228 is biased for operation from a single supply. An artificial signal ground at half supply voltage is generated with two 10k resistors and bypassed with a capacitor. A capacitor is used in series with R_G to set the DC gain of the current feedback amplifier to unity.

The transconductance amplifier is used as a variable resistor to control gain. A variable resistor is formed by driving the inverting input and connecting the output back to it. The equivalent resistor value is the inverse of the g_m . This works with the 1.8k resistor to make a variable attenuator. The 1MHz oscillation frequency is set by the Wien bridge network made up of two 1000pF capacitors and two 160Ω resistors.

For clean sine wave oscillation, the circuit needs a net gain of one around the loop. The current feedback amplifier has a gain of 34 to keep the voltage at the transconductance amplifier input low. The Wien bridge has an attenuation of

3 at resonance; therefore the attenuation of the 1.8k resistor and the transconductance amplifier must be about 11, resulting in a set current of about 600μA at oscillation. At start-up there is no set current and therefore no attenuation for a net gain of about 11 around the loop. As the output oscillation builds up it turns on the PNP transistor which generates the set current to regulate the output voltage.

12MHz Negative Resistance LC Oscillator

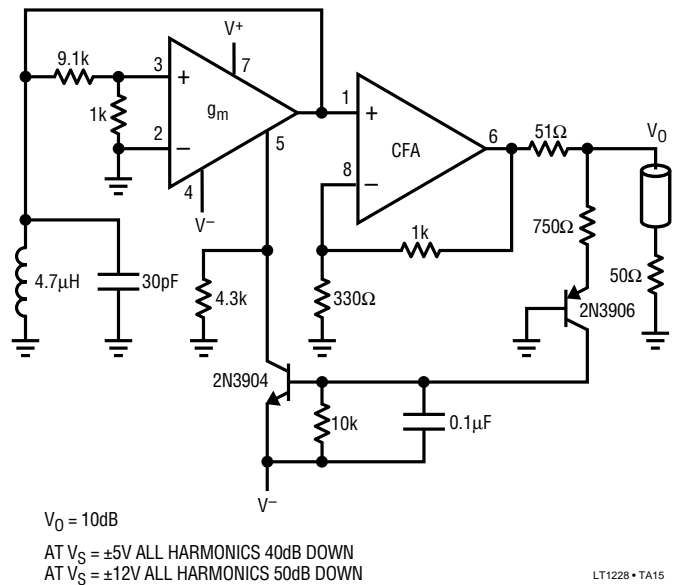

This oscillator uses the transconductance amplifier as a negative resistor to cause oscillation. A negative resistor results when the positive input of the transconductance amplifier is driven and the output is returned to it. In this example a voltage divider is used to lower the signal level at the positive input for less distortion. The negative resistor will not DC bias correctly unless the output of the transconductance amplifier drives a very low resistance. Here it sees an inductor to ground so the gain at DC is zero. The oscillator needs negative resistance to start and that is provided by the 4.3k resistor to pin 5. As the output level rises it turns on the PNP transistor and in turn the NPN which steals current from the transconductance amplifier bias input.

TYPICAL APPLICATIONS

Filters

Single Pole Low/High/Allpass Filter

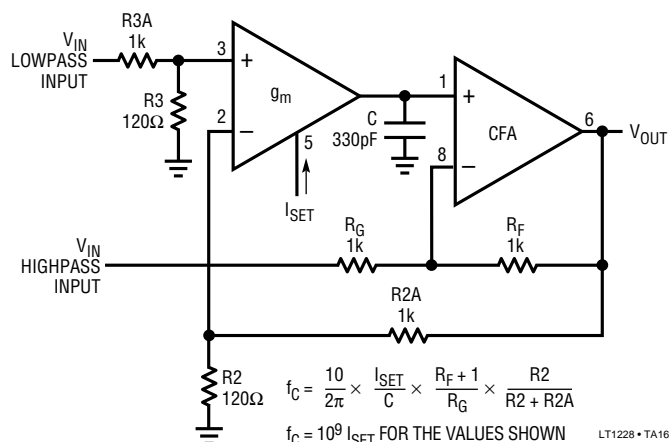

LT1228 • TA16

Allpass Filter Phase Response

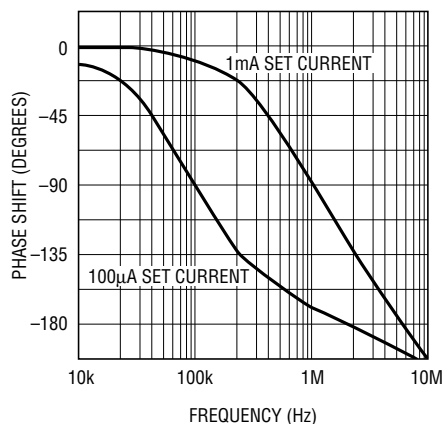

LT1228 • TA17

Using the variable transconductance of the LT1228 to make variable filters is easy and predictable. The most straight forward way is to make an integrator by putting a capacitor at the output of the transconductance amp and buffering it with the current feedback amplifier. Because the input bias current of the current feedback amplifier must be supplied by the transconductance amplifier, the set current should not be operated below 10µA. This limits the filters to about a 100:1 tuning range.

The Single Pole circuit realizes a single pole filter with a corner frequency (f_c) proportional to the set current. The

values shown give a 100kHz corner frequency for 100µA set current. The circuit has two inputs, a lowpass filter input and a highpass filter input. To make a lowpass filter, ground the highpass input and drive the lowpass input. Conversely for a highpass filter, ground the lowpass input and drive the highpass input. If both inputs are driven, the result is an allpass filter or phase shifter. The allpass has flat amplitude response and 0° phase shift at low frequencies, going to -180° at high frequencies. The allpass filter has -90° phase shift at the corner frequency.

TYPICAL APPLICATIONS

RF AGC Amplifier (Leveling Loop)

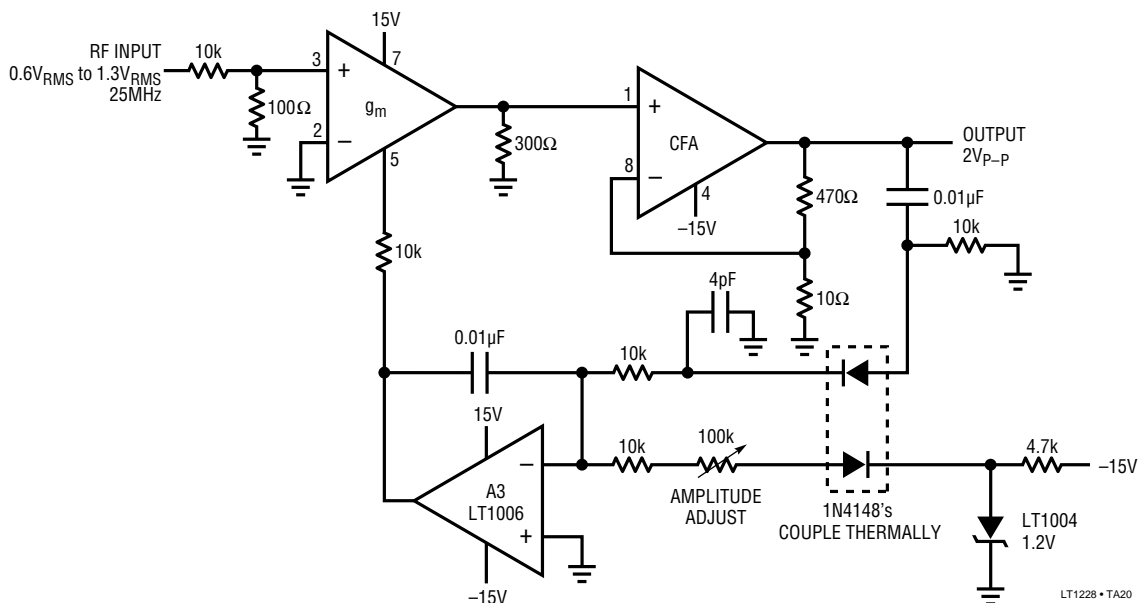

Inverting Amplifier with DC Output Less Than 5mV

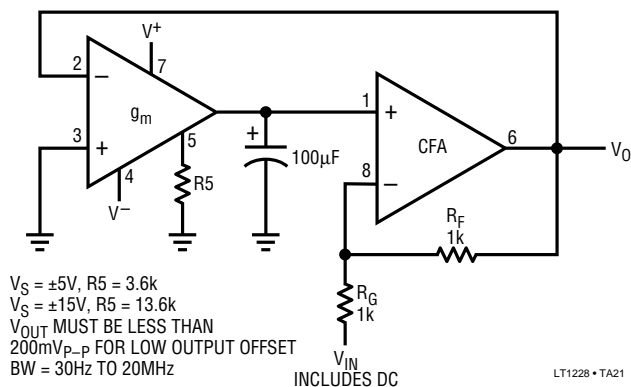

Amplitude Modulator

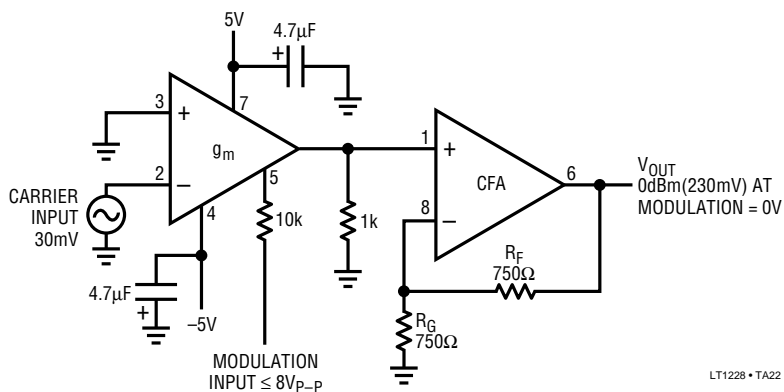

PACKAGE DESCRIPTION Dimensions in inches (millimeters) unless otherwise noted.

**J8 Package
8-Lead Ceramic DIP**

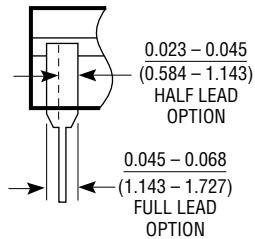
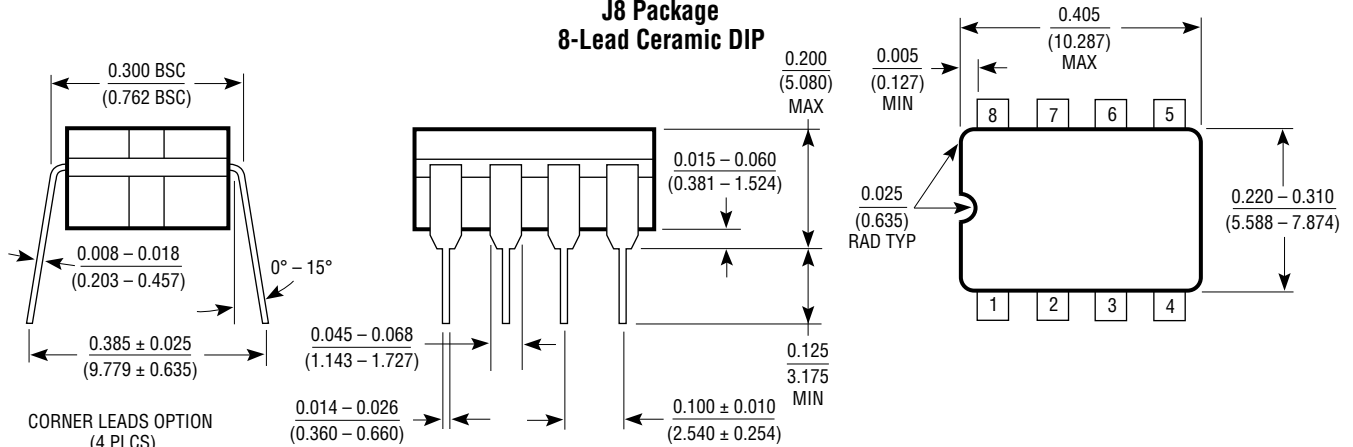

**N8 Package
8-Lead Plastic DIP**

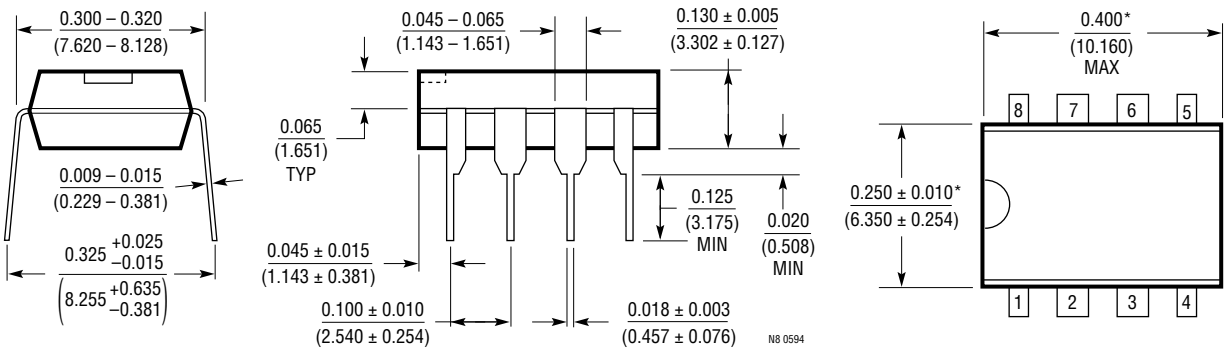

*THESE DIMENSIONS DO NOT INCLUDE MOLD FLASH OR PROTRUSIONS.
MOLD FLASH OR PROTRUSIONS SHALL NOT EXCEED 0.010 INCH (0.254mm).

**S8 Package
8-Lead Plastic SOIC**

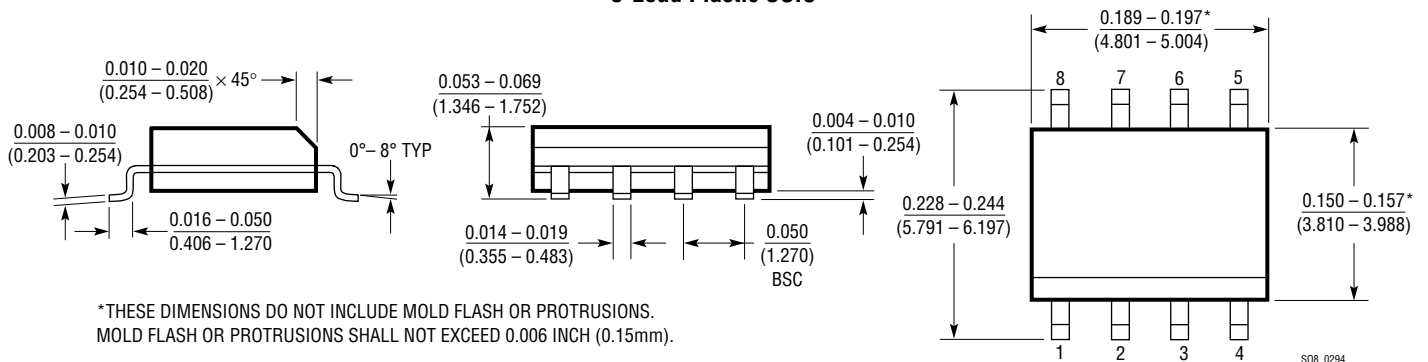

*THESE DIMENSIONS DO NOT INCLUDE MOLD FLASH OR PROTRUSIONS.
MOLD FLASH OR PROTRUSIONS SHALL NOT EXCEED 0.006 INCH (0.15mm).