

74LV244

Octal buffer/line driver (3-state)

Rev. 3 — 11 March 2014

Product data sheet

1. General description

The 74LV244 is a low-voltage Si-gate CMOS device and is pin and function compatible with 74HC244 and 74HCT244.

The 74LV244 is an octal non-inverting buffer/line driver with 3-state outputs. The output enable inputs $1\overline{OE}$ and $2\overline{OE}$ control the 3-state outputs. A HIGH on $n\overline{OE}$ causes the outputs to assume a high impedance OFF-state. The 74LV244 is identical to the 74LV240 but has non-inverting outputs.

2. Features and benefits

- Wide operating voltage: 1.0 V to 5.5 V
- Optimized for low voltage applications: 1.0 V to 3.6 V
- Accepts TTL input levels between $V_{CC} = 2.7$ V and $V_{CC} = 3.6$ V
- Typical V_{OLP} (output ground bounce) < 0.8 V at $V_{CC} = 3.3$ V; $T_{amb} = 25$ °C
- Typical V_{OHV} (output V_{OH} undershoot) > 2 V at $V_{CC} = 3.3$ V; $T_{amb} = 25$ °C
- Complies with JEDEC standard no. 7A
- ESD protection:
 - ◆ HBM JESD22-A114F exceeds 2000 V
 - ◆ MM JESD22-A115-A exceeds 200 V

3. Ordering information

Table 1. Ordering information

Type number	Package	Name	Description	Version
	Temperature range			
74LV244N	-40 °C to +125 °C	DIP20	plastic dual in-line package; 20 leads (300 mil)	SOT146-1
74LV244D	-40 °C to +125 °C	SO20	plastic small outline package; 20 leads; body width 7.5 mm	SOT163-1
74LV244DB	-40 °C to +125 °C	SSOP20	plastic shrink small outline package; 20 leads; body width 5.3 mm	SOT339-1
74LV244PW	-40 °C to +125 °C	TSSOP20	plastic thin shrink small outline package; 20 leads; body width 4.4 mm	SOT360-1



4. Block diagram

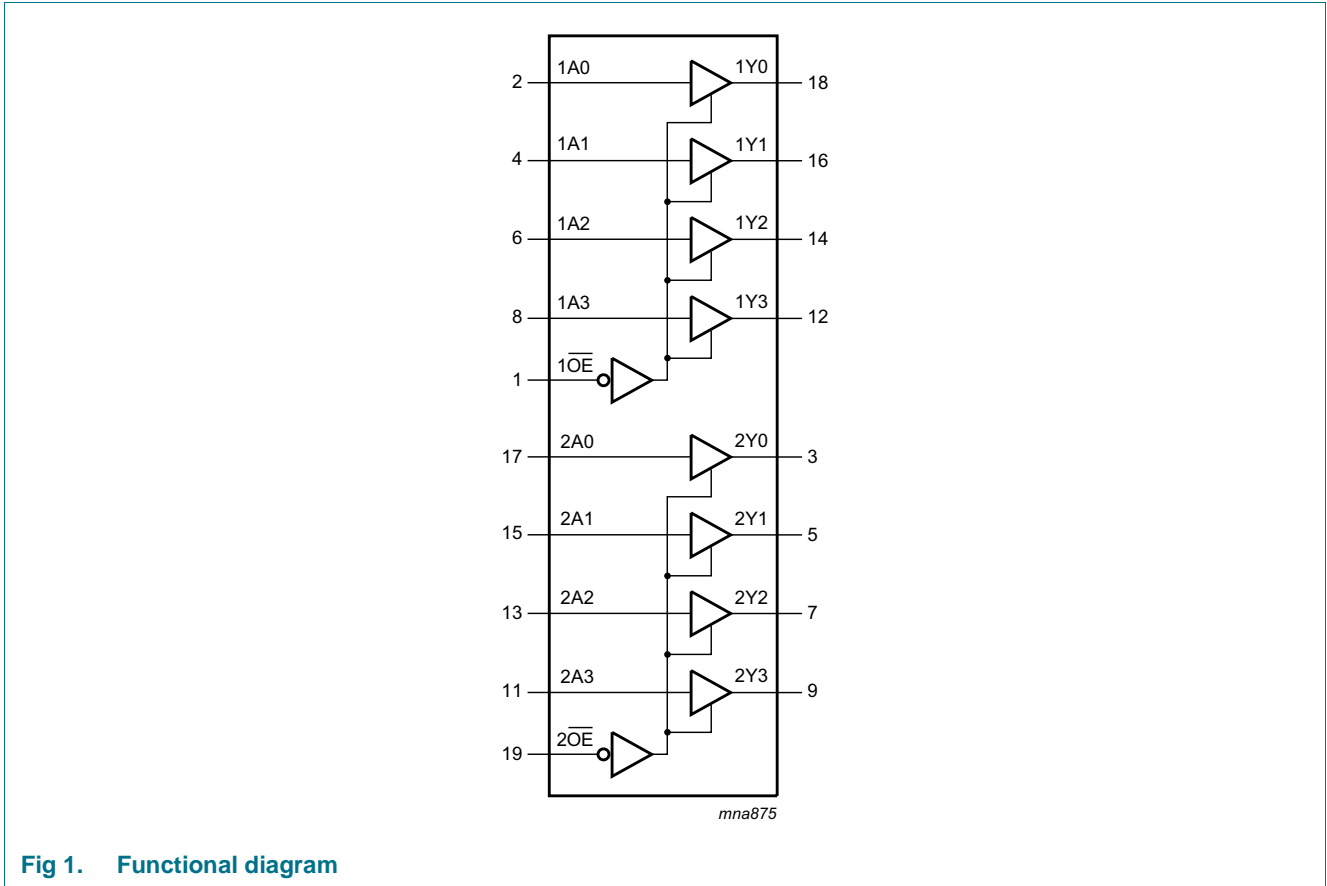

Fig 1. Functional diagram

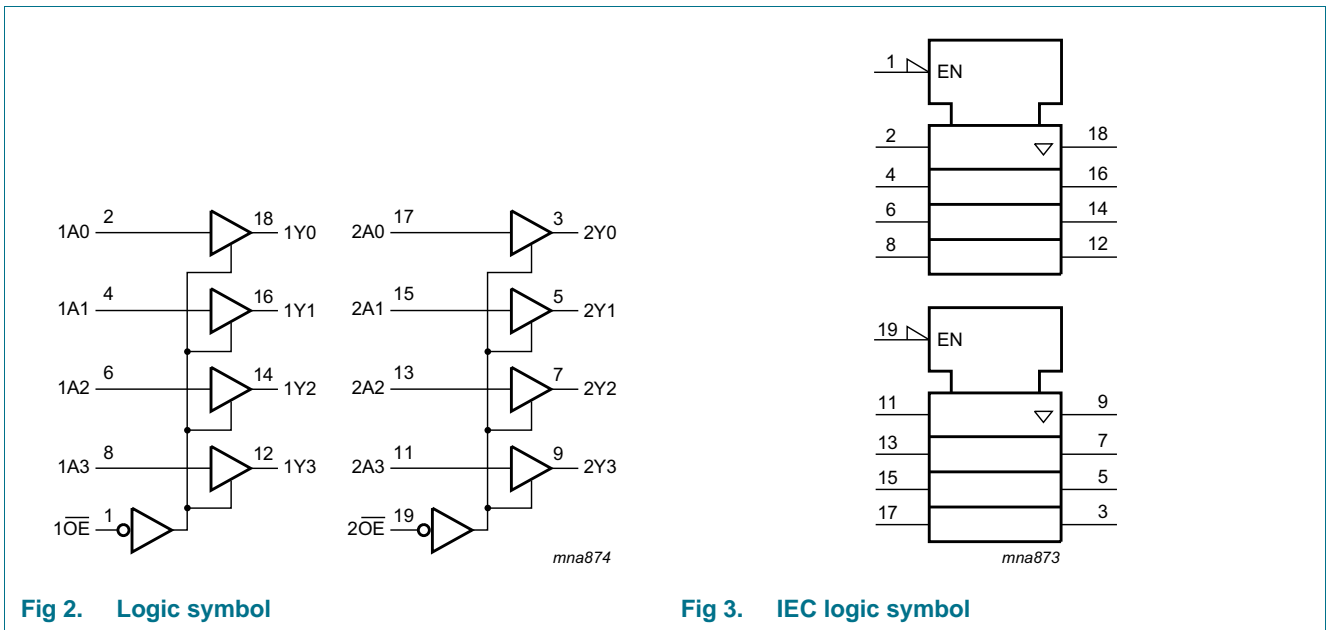

Fig 2. Logic symbol

Fig 3. IEC logic symbol

5. Pinning information

5.1 Pinning

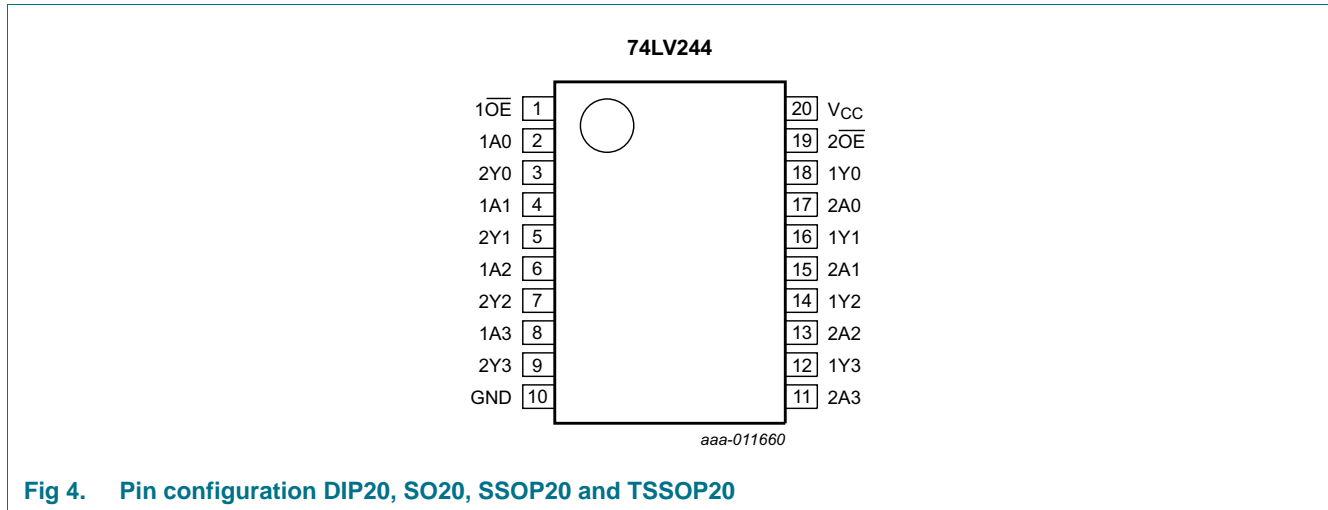

Fig 4. Pin configuration DIP20, SO20, SSOP20 and TSSOP20

5.2 Pin description

Table 2. Pin description

Symbol	Pin	Description
$1\overline{OE}, 2\overline{OE}$	1, 19	output enable input (active LOW)
1A0, 1A1, 1A2, 1A3	2, 4, 6, 8	data input
2Y0, 2Y1, 2Y2, 2Y3	3, 5, 7, 9	bus output
GND	10	ground (0 V)
2A0, 2A1, 2A2, 2A3	17, 15, 13, 11	data input
1Y0, 1Y1, 1Y2, 1Y3	18, 16, 14, 12	bus output
V _{CC}	20	supply voltage

6. Functional description

Table 3. Function table^[1]

Input		Output
$n\overline{OE}$	nAn	nYn
L	L	L
L	H	H
H	X	Z

[1] H = HIGH voltage level; L = LOW voltage level; X = don't care; Z = high-impedance OFF-state.

7. Limiting values

Table 4. Limiting values

In accordance with the Absolute Maximum Rating System (IEC 60134). Voltages are referenced to GND (ground = 0 V).

Symbol	Parameter	Conditions	Min	Max	Unit
V_{CC}	supply voltage		-0.5	+7.0	V
I_{IK}	input clamping current	$V_I < -0.5\text{ V}$ or $V_I > V_{CC} + 0.5\text{ V}$	-	± 20	mA
I_{OK}	output clamping current	$V_O < -0.5\text{ V}$ or $V_O > V_{CC} + 0.5\text{ V}$	-	± 50	mA
I_O	output current	$-0.5\text{ V} < V_O < V_{CC} + 0.5\text{ V}$	-	± 35	mA
I_{CC}	supply current		-	70	mA
I_{GND}	ground current		-70	-	mA
T_{stg}	storage temperature		-65	+150	°C
P_{tot}	total power dissipation	$T_{amb} = -40\text{ °C}$ to $+125\text{ °C}$			
		DIP20 package [1]	-	750	mW
		SO20 [2]	-	500	mW
		SSOP20 and TSSOP20 [3]	-	400	mW

[1] For DIP20 package: P_{tot} derates linearly with 12 mW/K above 70 °C.

[2] For SO20 packages: P_{tot} derates linearly with 8 mW/K above 70 °C.

[3] For SSOP20 and TSSOP20 packages: P_{tot} derates linearly with 5.5 mW/K above 60 °C.

8. Recommended operating conditions

Table 5. Operating conditions

Symbol	Parameter	Conditions	Min	Typ	Max	Unit
V_{CC}	supply voltage	[1]	1.0	3.3	5.5	V
V_I	input voltage		0	-	V_{CC}	V
V_O	output voltage		0	-	V_{CC}	V
T_{amb}	ambient temperature		-40	-	+85	°C
			-40	-	+125	°C
$\Delta t/\Delta V$	input transition rise and fall rate	$V_{CC} = 1.0\text{ V}$ to 2.0 V	0	-	500	ns/V
		$V_{CC} = 2.0\text{ V}$ to 2.7 V	0	-	200	ns/V
		$V_{CC} = 2.7\text{ V}$ to 3.6 V	0	-	100	ns/V
		$V_{CC} = 3.6\text{ V}$ to 5.5 V	0	-	50	ns/V

[1] The LV is guaranteed to function down to $V_{CC} = 1.0\text{ V}$ (input levels GND or V_{CC}). DC characteristics are guaranteed from $V_{CC} = 1.2\text{ V}$ to $V_{CC} = 5.5\text{ V}$.

9. Static characteristics

Table 6. Static characteristics

Over recommended operating conditions. Voltages are referenced to GND (ground = 0 V).

Symbol	Parameter	Conditions	-40 °C to +85 °C			-40 °C to +125 °C		Unit
			Min	Typ ^[1]	Max	Min	Max	
V _{IH}	HIGH level input voltage	V _{CC} = 1.2 V	0.9	-	-	0.9		V
		V _{CC} = 2.0 V	1.4	-	-	1.4		V
		V _{CC} = 2.7 V to 3.6 V	2.0	-	-	2.0		V
		V _{CC} = 4.5 V to 5.5 V	0.7V _{CC}	-	-	0.7V _{CC}		V
V _{IL}	LOW level input voltage	V _{CC} = 1.2 V	-	-	0.3		0.3	V
		V _{CC} = 2.0 V	-	-	0.6		0.6	V
		V _{CC} = 2.7 V to 3.6 V	-	-	0.8		0.8	V
		V _{CC} = 4.5 V to 5.5 V	-	-	0.3V _{CC}		0.3V _{CC}	V
V _{OH}	HIGH level output voltage	V _I = V _{IH} or V _{IL} ; I _O = -100 μA						
		V _{CC} = 1.2 V	-	1.2	-	-	-	V
		V _{CC} = 2.0 V	1.8	2.0	-	1.8	-	V
		V _{CC} = 2.7 V	2.5	2.7	-	2.5	-	V
		V _{CC} = 3.0 V	2.8	3.0	-	2.8	-	V
		V _{CC} = 4.5 V	4.3	4.5	-	4.3	-	V
		V _I = V _{IH} or V _{IL}						
		V _{CC} = 3.0 V; I _O = -8 mA	2.40	2.82	-	2.20	-	V
V _{CC} = 4.5 V; I _O = -16 mA	3.60	4.20	-	3.50	-	V		
V _{OL}	LOW level output voltage	V _I = V _{IH} or V _{IL} ; I _O = 100 μA						
		V _{CC} = 1.2 V	-	0	-	-	-	V
		V _{CC} = 2.0 V	-	0	0.2	-	0.2	V
		V _{CC} = 2.7 V	-	0	0.2	-	0.2	V
		V _{CC} = 3.0 V	-	0	0.2	-	0.2	V
		V _{CC} = 4.5 V	-	0	0.2	-	0.2	V
		V _{CC} = 3.0 V; I _O = 8 mA	-	0.25	0.40	-	0.50	V
		V _{CC} = 4.5 V; I _O = 16 mA	-	0.35	0.55	-	0.65	V
I _I	input leakage current	V _{CC} = 5.5 V; V _I = V _{CC} or GND	-	-	1.0	-	1.0	μA
I _{OZ}	3-State output OFF-state current	V _{CC} = 3.6 V; V _I = V _{IH} or V _{IL} ; V _O = V _{CC} or GND	-	-	5	-	10	μA
I _{CC}	supply current	V _{CC} = 5.5 V; V _I = V _{CC} or GND; I _O = 0 A	-	-	20	-	160	μA
ΔI _{CC}	additional supply current	per input; V _{CC} = 2.7 V to 3.6 V; V _I = V _{CC} - 0.6 V	-	-	500	-	850	μA
C _I	input capacitance		-	3.5	-	-	-	pF

[1] All typical values are measured at T_{amb} = 25 °C.

10. Dynamic characteristics

Table 7. Dynamic characteristics

GND (ground = 0 V); for test circuit, see [Figure 7](#)

Symbol	Parameter	Conditions	-40 °C to +85 °C			-40 °C to +125 °C		Unit
			Min	Typ ^[1]	Max	Min	Max	
t _{pd}	propagation delay	1An to 1Yn; 2An to 2Yn; see Figure 5 ^[2]						
		V _{CC} = 1.2 V	-	50		-	-	ns
		V _{CC} = 2.0 V	-	17	24	-	31	ns
		V _{CC} = 2.7 V	-	13	17	-	23	ns
		V _{CC} = 3.0 V to 3.6 V	-	9	14	-	18	ns
		V _{CC} = 3.3 V; C _L = 15 pF	-	8.0	-	-	-	ns
		V _{CC} = 4.5 V to 5.5 V	-	-	12	-	15	ns
t _{en}	enable time	1 $\overline{O}E$ to 1Yn; 2 $\overline{O}E$ to 2Yn; see Figure 6 ^[2]						
		V _{CC} = 1.2 V	-	65	-	-	-	ns
		V _{CC} = 2.0 V	-	22	39	-	49	ns
		V _{CC} = 2.7 V	-	16	29	-	36	ns
		V _{CC} = 3.0 V to 3.6 V	-	12	23	-	29	ns
		V _{CC} = 4.5 V to 5.5 V	-	-	19	-	24	ns
t _{dis}	disable time	1 $\overline{O}E$ to 1Yn; 2 $\overline{O}E$ to 2Yn; see Figure 6 ^[2]						
		V _{CC} = 1.2 V	-	60		-	-	ns
		V _{CC} = 2.0 V	-	22	34	-	43	ns
		V _{CC} = 2.7 V	-	17	24	-	32	ns
		V _{CC} = 3.0 V to 3.6 V	-	13	21	-	26	ns
		V _{CC} = 4.5 V to 5.5 V	-	-	16	-	19	ns
C _{PD}	power dissipation capacitance	V _I = GND to V _{CC} ; V _{CC} = 3.3 V ^[3]	-	35	-	-	-	ns

[1] Unless otherwise stated, all typical values are measured at T_{amb} = 25 °C and nominal V_{CC}.

[2] t_{pd} is the same as t_{PLH} and t_{PHL}.

t_{en} is the same as t_{PZL} and t_{PZH}.

t_{dis} is the same as t_{PLZ} and t_{PHZ}.

[3] C_{PD} is used to determine the dynamic power dissipation P_D = C_{PD} × V_{CC}² × f_i + Σ (C_L × V_{CC}² × f_o) (P_D in μW), where:

f_i = input frequency in MHz;

f_o = output frequency in MHz;

Σ (C_L × V_{CC}² × f_o) = sum of outputs;

C_L = output load capacitance in pF;

V_{CC} = supply voltage in V.

11. Waveforms

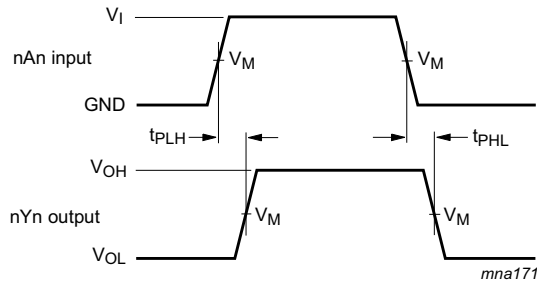

Measurement points are given in [Table 8](#).
 V_{OL} and V_{OH} are typical voltage output levels that occur with the output load.

Fig 5. Input (nAn) to output (nYn) propagation delays

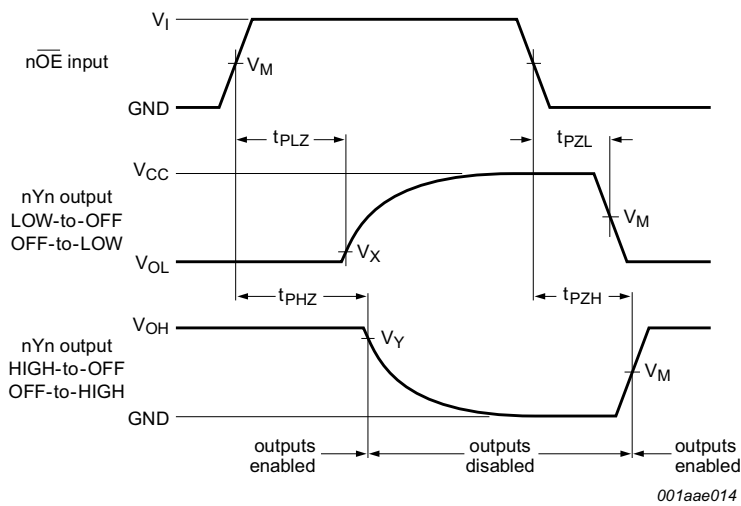

Measurement points are given in [Table 8](#).
 V_{OL} and V_{OH} are typical voltage output levels that occur with the output load.

Fig 6. 3-state enable and disable times

Table 8. Measurement points

Supply voltage	Input	Output		
V_{CC}	V_M	V_M	V_X	V_Y
< 2.7 V	$0.5V_{CC}$	$0.5V_{CC}$	$V_{OL} + 0.1V_{CC}$	$V_{OH} - 0.1V_{CC}$
2.7 V to 3.6 V	1.5 V	1.5 V	$V_{OL} + 0.3 V$	$V_{OH} - 0.3 V$
$\geq 4.5 V$	$0.5V_{CC}$	$0.5V_{CC}$	$V_{OL} + 0.1V_{CC}$	$V_{OH} - 0.1V_{CC}$

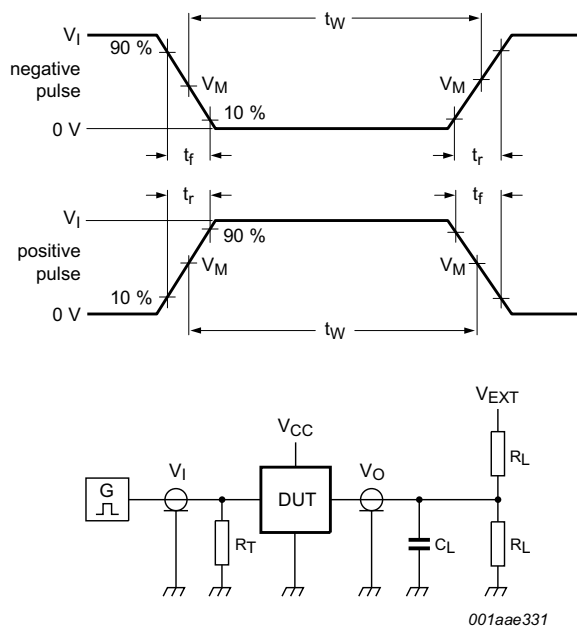

Test data is given in [Table 9](#).

Definitions test circuit:

R_T = Termination resistance should be equal to output impedance Z_o of the pulse generator.

C_L = Load capacitance including jig and probe capacitance.

R_L = Load resistance.

S1 = Test selection switch.

Fig 7. Test circuit for measuring switching times

Table 9. Test data

Supply voltage	Input		Load		V_{EXT}		
V_{CC}	V_I	t_r, t_f	C_L	R_L	t_{PHL}, t_{PLH}	t_{PZH}, t_{PHZ}	t_{PZL}, t_{PLZ}
< 2.7 V	V_{CC}	≤ 2.5 ns	50 pF	1 k Ω	open	GND	$2V_{CC}$
2.7 V to 3.6 V	2.7 V	≤ 2.5 ns	15 pF, 50 pF	1 k Ω	open	GND	$2V_{CC}$
≥ 4.5 V	V_{CC}	≤ 2.5 ns	50 pF	1 k Ω	open	GND	$2V_{CC}$

12. Package outline

DIP20: plastic dual in-line package; 20 leads (300 mil)

SOT146-1

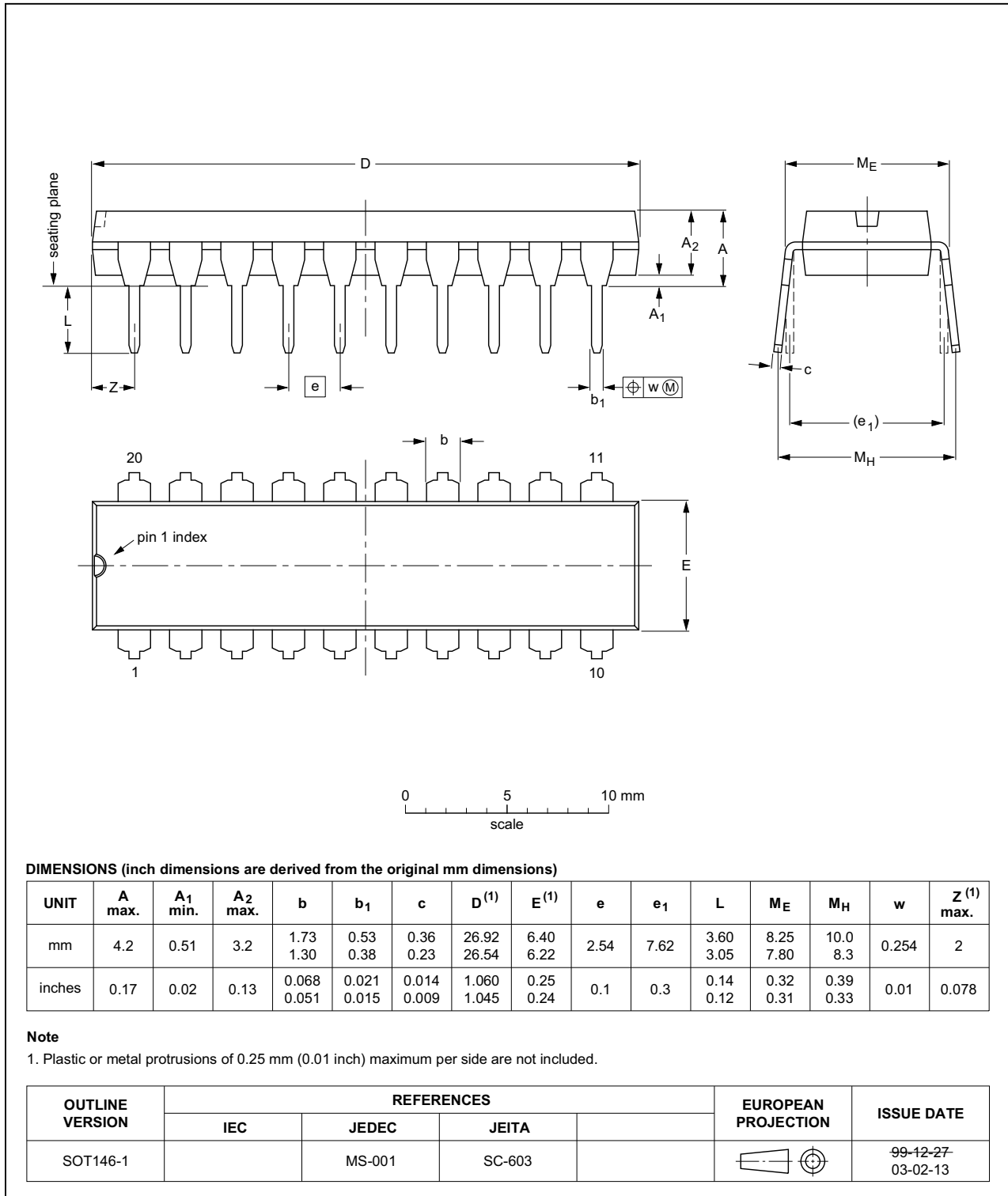

Fig 8. Package outline SOT146-1 (DIP20)

SO20: plastic small outline package; 20 leads; body width 7.5 mm

SOT163-1

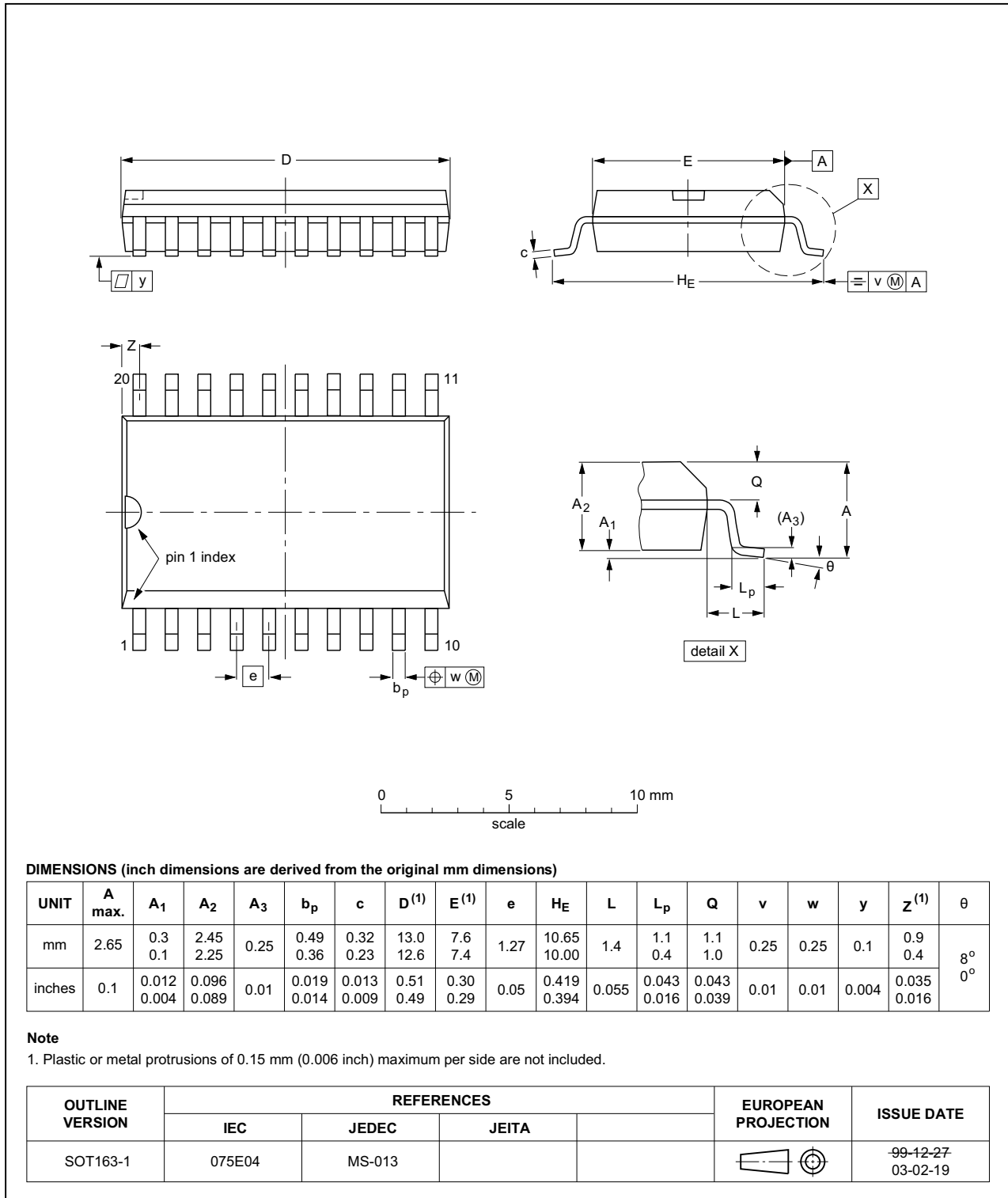

Fig 9. Package outline SOT163-1 (SO20)

SSOP20: plastic shrink small outline package; 20 leads; body width 5.3 mm

SOT339-1

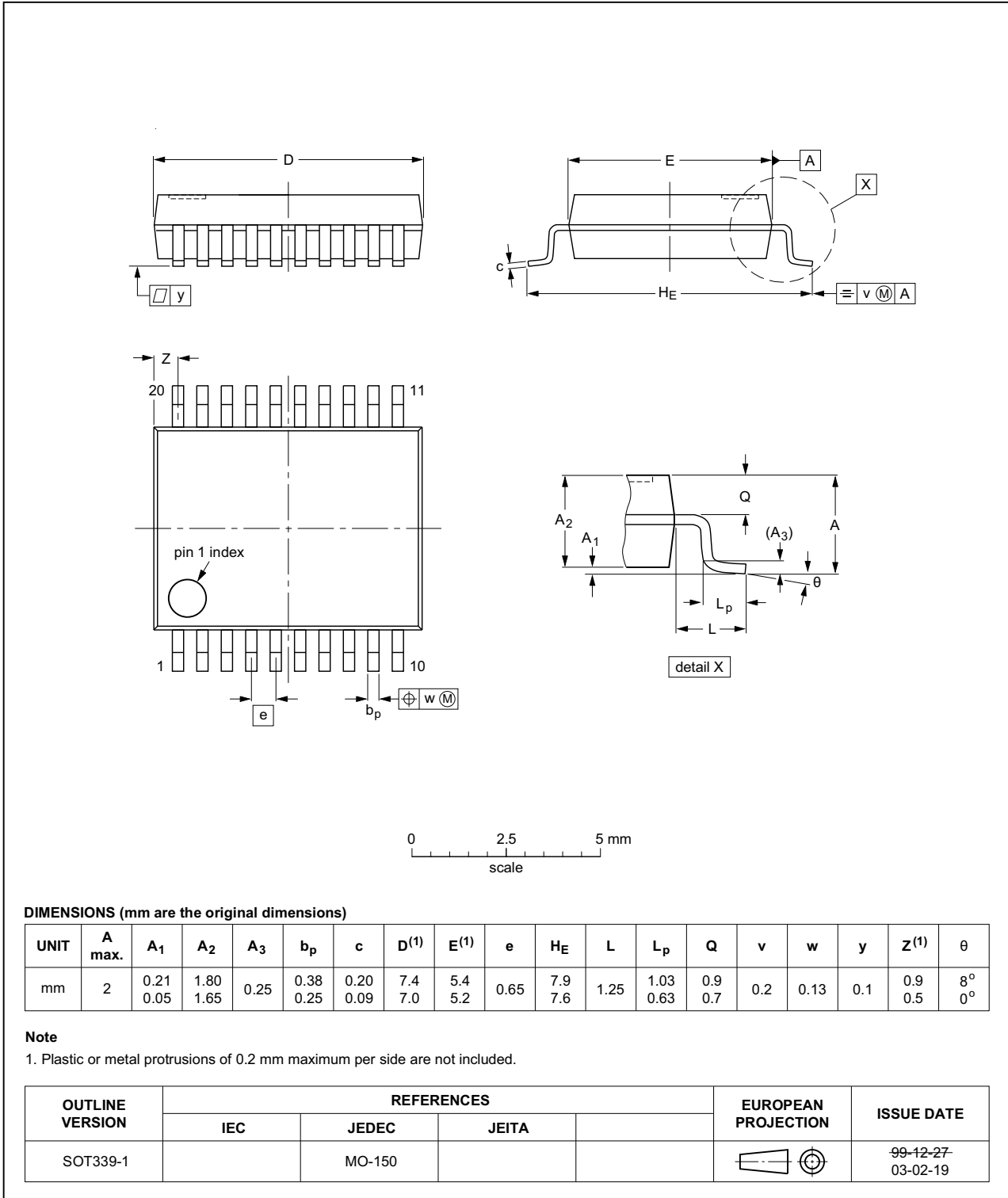

Fig 10. Package outline SOT339-1 (SSOP20)

TSSOP20: plastic thin shrink small outline package; 20 leads; body width 4.4 mm

SOT360-1

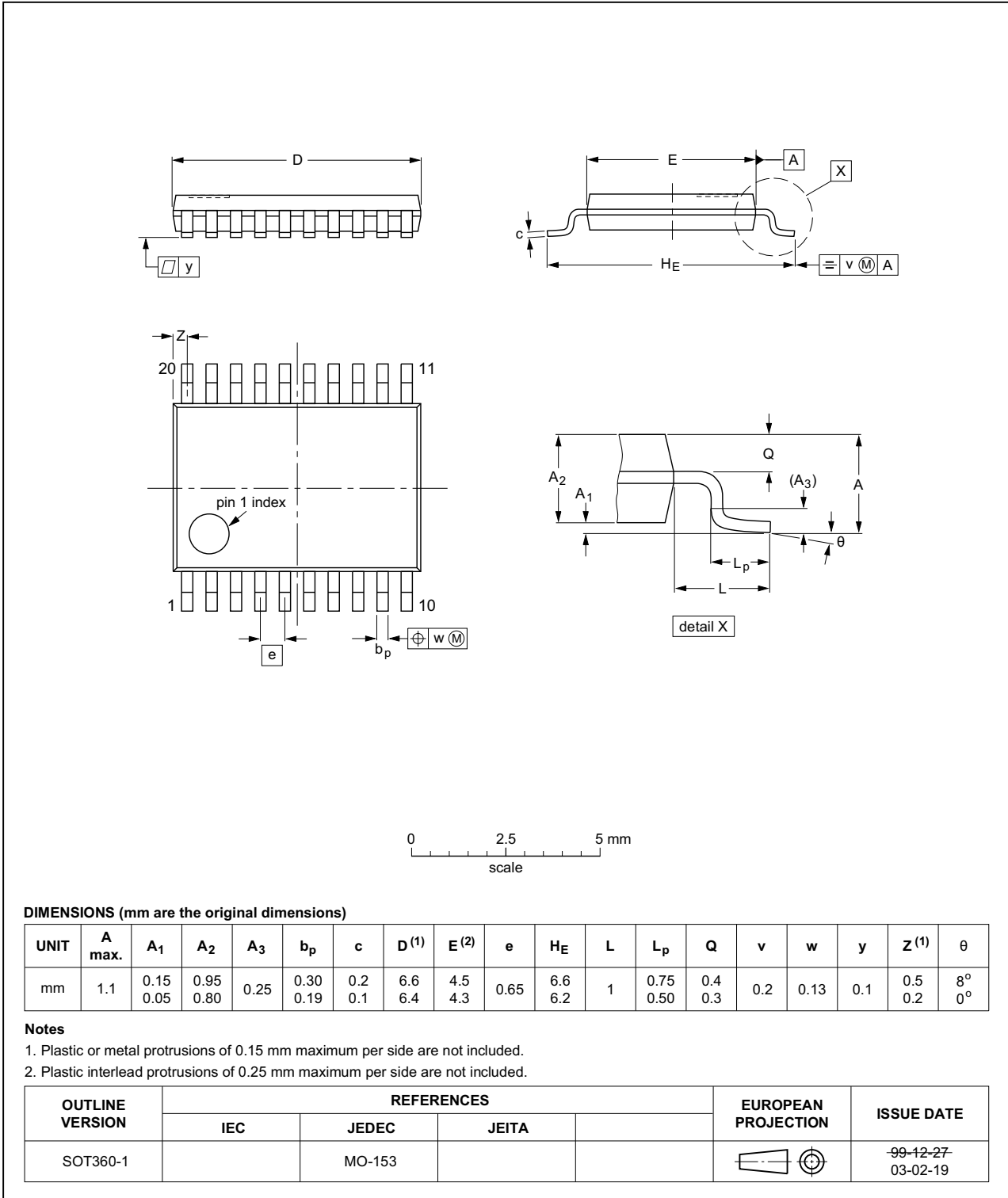

Fig 11. Package outline SOT360-1 (TSSOP20)

13. Abbreviations

Table 10. Abbreviations

Acronym	Description
CMOS	Complementary Metal Oxide Semiconductor
DUT	Device Under Test
ESD	ElectroStatic Discharge
HBM	Human Body Model
MM	Machine Model
TTL	Transistor-Transistor Logic

14. Revision history

Table 11. Revision history

Document ID	Release date	Data sheet status	Change notice	Supersedes
74LV244 v.3	20140311	Product data sheet	-	74LV244 v.2
Modifications:	<ul style="list-style-type: none"> The format of this data sheet has been redesigned to comply with the new identity guidelines of NXP Semiconductors. Legal texts have been adapted to the new company name where appropriate. 			
74LV244 v.2	19980520	Product specification	-	74LV244 v.1
74LV244 v.1	-	-	-	-

15. Legal information

15.1 Data sheet status

Document status ^{[1][2]}	Product status ^[3]	Definition
Objective [short] data sheet	Development	This document contains data from the objective specification for product development.
Preliminary [short] data sheet	Qualification	This document contains data from the preliminary specification.
Product [short] data sheet	Production	This document contains the product specification.

[1] Please consult the most recently issued document before initiating or completing a design.

[2] The term 'short data sheet' is explained in section "Definitions".

[3] The product status of device(s) described in this document may have changed since this document was published and may differ in case of multiple devices. The latest product status information is available on the Internet at URL <http://www.nxp.com>.

15.2 Definitions

Draft — The document is a draft version only. The content is still under internal review and subject to formal approval, which may result in modifications or additions. NXP Semiconductors does not give any representations or warranties as to the accuracy or completeness of information included herein and shall have no liability for the consequences of use of such information.

Short data sheet — A short data sheet is an extract from a full data sheet with the same product type number(s) and title. A short data sheet is intended for quick reference only and should not be relied upon to contain detailed and full information. For detailed and full information see the relevant full data sheet, which is available on request via the local NXP Semiconductors sales office. In case of any inconsistency or conflict with the short data sheet, the full data sheet shall prevail.

Product specification — The information and data provided in a Product data sheet shall define the specification of the product as agreed between NXP Semiconductors and its customer, unless NXP Semiconductors and customer have explicitly agreed otherwise in writing. In no event however, shall an agreement be valid in which the NXP Semiconductors product is deemed to offer functions and qualities beyond those described in the Product data sheet.

15.3 Disclaimers

Limited warranty and liability — Information in this document is believed to be accurate and reliable. However, NXP Semiconductors does not give any representations or warranties, expressed or implied, as to the accuracy or completeness of such information and shall have no liability for the consequences of use of such information. NXP Semiconductors takes no responsibility for the content in this document if provided by an information source outside of NXP Semiconductors.

In no event shall NXP Semiconductors be liable for any indirect, incidental, punitive, special or consequential damages (including - without limitation - lost profits, lost savings, business interruption, costs related to the removal or replacement of any products or rework charges) whether or not such damages are based on tort (including negligence), warranty, breach of contract or any other legal theory.

Notwithstanding any damages that customer might incur for any reason whatsoever, NXP Semiconductors' aggregate and cumulative liability towards customer for the products described herein shall be limited in accordance with the *Terms and conditions of commercial sale* of NXP Semiconductors.

Right to make changes — NXP Semiconductors reserves the right to make changes to information published in this document, including without limitation specifications and product descriptions, at any time and without notice. This document supersedes and replaces all information supplied prior to the publication hereof.

Suitability for use — NXP Semiconductors products are not designed, authorized or warranted to be suitable for use in life support, life-critical or safety-critical systems or equipment, nor in applications where failure or malfunction of an NXP Semiconductors product can reasonably be expected to result in personal injury, death or severe property or environmental damage. NXP Semiconductors and its suppliers accept no liability for inclusion and/or use of NXP Semiconductors products in such equipment or applications and therefore such inclusion and/or use is at the customer's own risk.

Applications — Applications that are described herein for any of these products are for illustrative purposes only. NXP Semiconductors makes no representation or warranty that such applications will be suitable for the specified use without further testing or modification.

Customers are responsible for the design and operation of their applications and products using NXP Semiconductors products, and NXP Semiconductors accepts no liability for any assistance with applications or customer product design. It is customer's sole responsibility to determine whether the NXP Semiconductors product is suitable and fit for the customer's applications and products planned, as well as for the planned application and use of customer's third party customer(s). Customers should provide appropriate design and operating safeguards to minimize the risks associated with their applications and products.

NXP Semiconductors does not accept any liability related to any default, damage, costs or problem which is based on any weakness or default in the customer's applications or products, or the application or use by customer's third party customer(s). Customer is responsible for doing all necessary testing for the customer's applications and products using NXP Semiconductors products in order to avoid a default of the applications and the products or of the application or use by customer's third party customer(s). NXP does not accept any liability in this respect.

Limiting values — Stress above one or more limiting values (as defined in the Absolute Maximum Ratings System of IEC 60134) will cause permanent damage to the device. Limiting values are stress ratings only and (proper) operation of the device at these or any other conditions above those given in the Recommended operating conditions section (if present) or the Characteristics sections of this document is not warranted. Constant or repeated exposure to limiting values will permanently and irreversibly affect the quality and reliability of the device.

Terms and conditions of commercial sale — NXP Semiconductors products are sold subject to the general terms and conditions of commercial sale, as published at <http://www.nxp.com/profile/terms>, unless otherwise agreed in a valid written individual agreement. In case an individual agreement is concluded only the terms and conditions of the respective agreement shall apply. NXP Semiconductors hereby expressly objects to applying the customer's general terms and conditions with regard to the purchase of NXP Semiconductors products by customer.

No offer to sell or license — Nothing in this document may be interpreted or construed as an offer to sell products that is open for acceptance or the grant, conveyance or implication of any license under any copyrights, patents or other industrial or intellectual property rights.

Export control — This document as well as the item(s) described herein may be subject to export control regulations. Export might require a prior authorization from competent authorities.

Non-automotive qualified products — Unless this data sheet expressly states that this specific NXP Semiconductors product is automotive qualified, the product is not suitable for automotive use. It is neither qualified nor tested in accordance with automotive testing or application requirements. NXP Semiconductors accepts no liability for inclusion and/or use of non-automotive qualified products in automotive equipment or applications.

In the event that customer uses the product for design-in and use in automotive applications to automotive specifications and standards, customer (a) shall use the product without NXP Semiconductors' warranty of the

product for such automotive applications, use and specifications, and (b) whenever customer uses the product for automotive applications beyond NXP Semiconductors' specifications such use shall be solely at customer's own risk, and (c) customer fully indemnifies NXP Semiconductors for any liability, damages or failed product claims resulting from customer design and use of the product for automotive applications beyond NXP Semiconductors' standard warranty and NXP Semiconductors' product specifications.

15.4 Trademarks

Notice: All referenced brands, product names, service names and trademarks are the property of their respective owners.

16. Contact information

For more information, please visit: <http://www.nxp.com>

For sales office addresses, please send an email to: salesaddresses@nxp.com

17. Contents

1	General description	1
2	Features and benefits	1
3	Ordering information	1
4	Block diagram	2
5	Pinning information	3
5.1	Pinning	3
5.2	Pin description	3
6	Functional description	3
7	Limiting values	4
8	Recommended operating conditions	4
9	Static characteristics	5
10	Dynamic characteristics	6
11	Waveforms	7
12	Package outline	9
13	Abbreviations	13
14	Revision history	13
15	Legal information	14
15.1	Data sheet status	14
15.2	Definitions	14
15.3	Disclaimers	14
15.4	Trademarks	15
16	Contact information	15
17	Contents	16

Please be aware that important notices concerning this document and the product(s) described herein, have been included in section 'Legal information'.

© NXP Semiconductors N.V. 2014.

All rights reserved.

For more information, please visit: <http://www.nxp.com>

For sales office addresses, please send an email to: salesaddresses@nxp.com

Date of release: 11 March 2014

Document identifier: 74LV244