

74LVT162374

3.3 V 16-bit edge-triggered D-type flip-flop with 30 Ω termination resistors; 3-state

Rev. 03 — 17 January 2005

Product data sheet

1. General description

The 74LVT162374 is a high performance BiCMOS product designed for V_{CC} operation at 3.3 V.

The 74LVT162374 is designed with 30 Ω series resistance in both the HIGH and LOW states of the output. This design reduces line noise in applications such as memory address drivers, clock drivers, and bus receivers/transmitters.

This device is a 16-bit edge-triggered D-type flip-flop featuring non-inverting 3-state outputs. The device can be used as two 8-bit flip-flops or one 16-bit flip-flop. On the positive transition of the clock (CP), the Q outputs of the flip-flop take on the logic levels set up at the D inputs.

2. Features

- 16-bit edge-triggered flip-flop
- 3-state buffers
- Output capability: +12 mA and -12 mA
- TTL input and output switching levels
- Input and output interface capability to systems at 5 V supply
- Bus-hold data inputs eliminate the need for external pull-up resistors to hold unused inputs
- Live insertion and extraction permitted
- Outputs include series resistance of 30 Ω making external resistors unnecessary
- Power-up reset
- Power-up 3-state
- No bus current loading when output is tied to 5 V bus
- Latch-up protection exceeds 500 mA per JESD78
- ESD protection:
 - ◆ MIL STD 883 method 3015: exceeds 2000 V
 - ◆ Machine model: exceeds 200 V

PHILIPS

3. Quick reference data

Table 1: Quick reference data

$T_{amb} = 25\text{ }^{\circ}\text{C}$.

Symbol	Parameter	Conditions	Min	Typ	Max	Unit
t_{PLH} , t_{PHL}	propagation delay nCP to nQn	$C_L = 50\text{ pF}$; $V_{CC} = 3.3\text{ V}$	-	3.0	-	ns
C_I	input capacitance	$V_I = 0\text{ V}$ or 3.0 V	-	3	-	pF
C_O	output capacitance	outputs disabled; $V_O = 0\text{ V}$ or 3.0 V	-	9	-	pF
I_{CC}	supply current	outputs disabled; $V_{CC} = 3.6\text{ V}$	-	70	-	μA

4. Ordering information

Table 2: Ordering information

Type number	Package			
	Temperature range	Name	Description	Version
74LVT162374DGG	$-40\text{ }^{\circ}\text{C}$ to $+85\text{ }^{\circ}\text{C}$	TSSOP48	plastic thin shrink small outline package; 48 leads; body width 6.1 mm	SOT362-1
74LVT162374DL	$-40\text{ }^{\circ}\text{C}$ to $+85\text{ }^{\circ}\text{C}$	SSOP48	plastic shrink small outline package; 48 leads; body width 7.5 mm	SOT370-1

5. Functional diagram

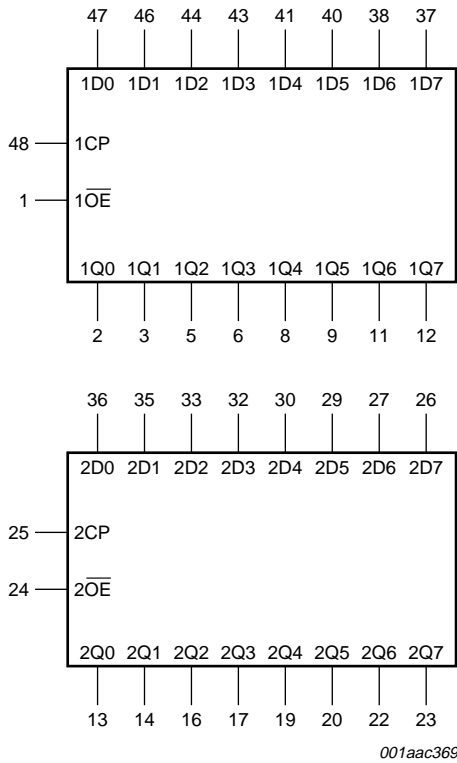

Fig 1. Logic symbol

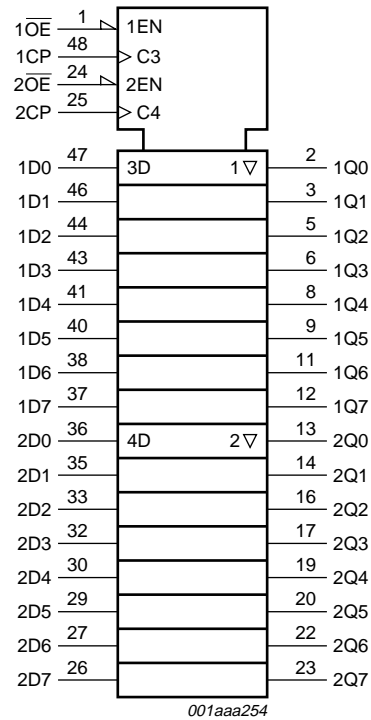

Fig 2. IEC logic symbol

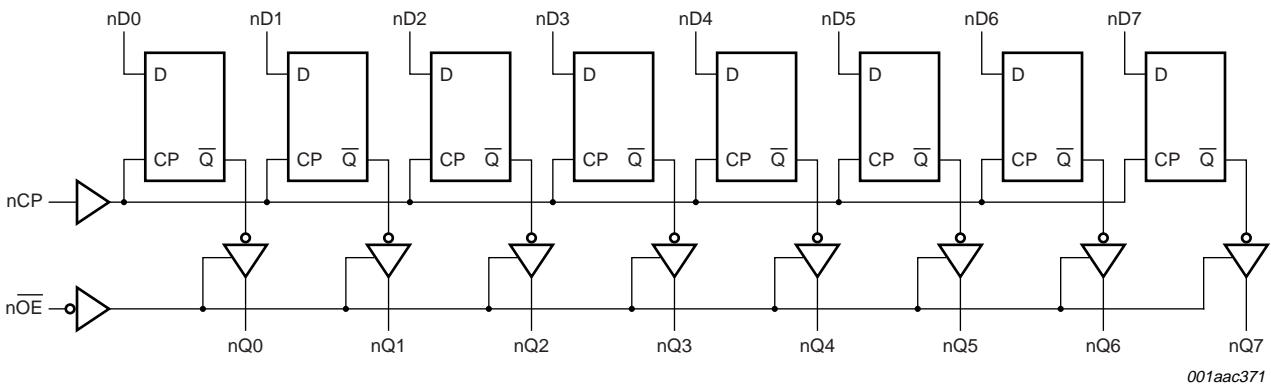
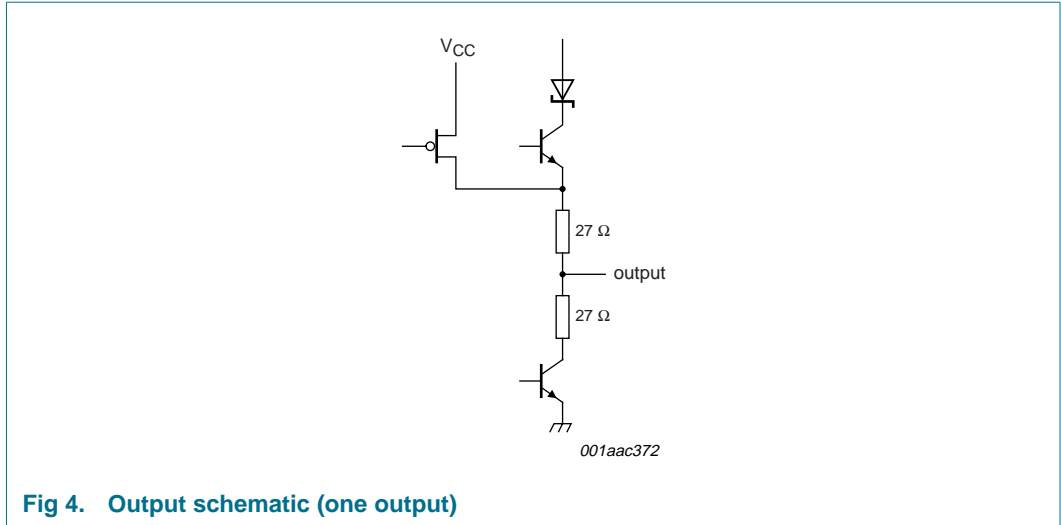
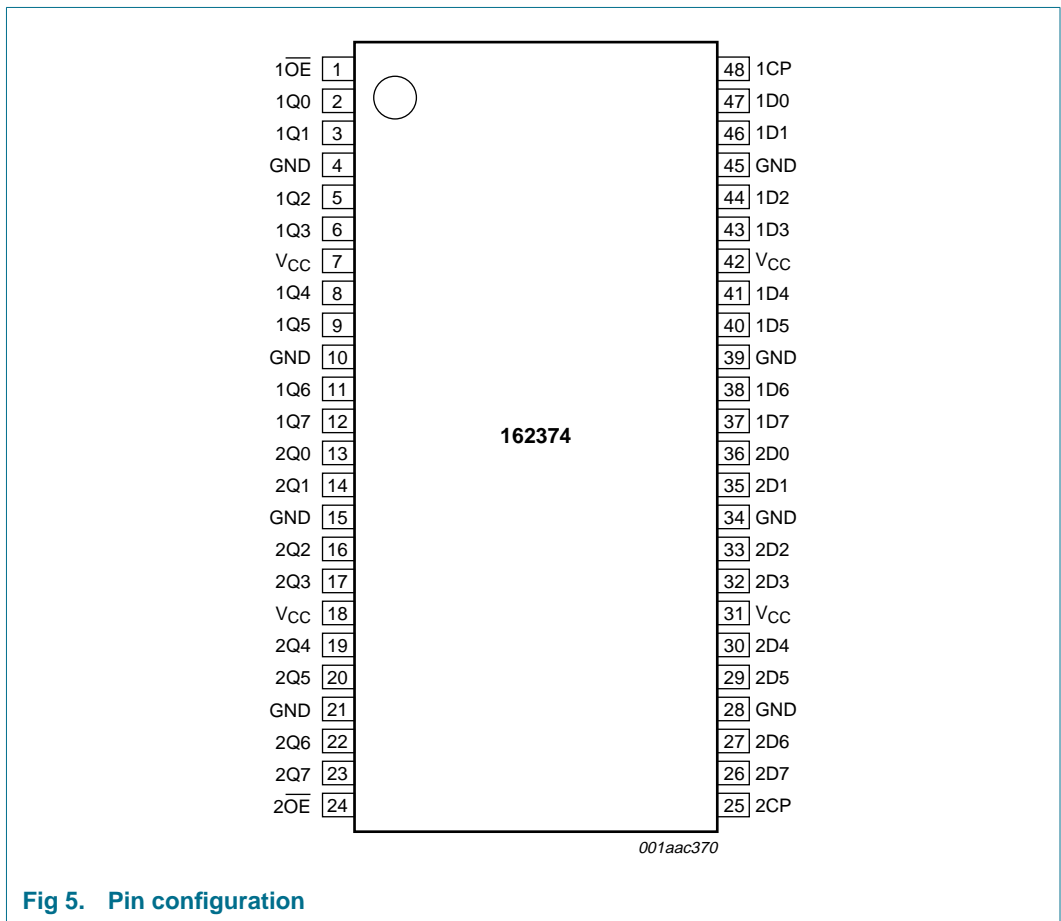

Fig 3. Logic diagram



6. Pinning information

6.1 Pinning



6.2 Pin description

Table 3: Pin description

Symbol	Pin	Description
$1\overline{OE}$	1	output enable input (active LOW)
1Q0	2	data output
1Q1	3	data output
GND	4	ground (0 V)
1Q2	5	data output
1Q3	6	data output
V _{CC}	7	supply voltage
1Q4	8	data output
1Q5	9	data output
GND	10	ground (0 V)
1Q6	11	data output
1Q7	12	data output
2Q0	13	data output
2Q1	14	data output
GND	15	ground (0 V)
2Q2	16	data output
2Q3	17	data output
V _{CC}	18	supply voltage
2Q4	19	data output
2Q5	20	data output
GND	21	ground (0 V)
2Q6	22	data output
2Q7	23	data output
$2\overline{OE}$	24	output enable input (active LOW)
2CP	25	clock pulse input (active rising edge)
2D7	26	data input
2D6	27	data input
GND	28	ground (0 V)
2D5	29	data input
2D4	30	data input
V _{CC}	31	supply voltage
2D3	32	data input
2D2	33	data input
GND	34	ground (0 V)
2D1	35	data input
2D0	36	data input
1D7	37	data input
1D6	38	data input
GND	39	ground (0 V)

Table 3: Pin description

Symbol	Pin	Description
1D5	40	data input
1D4	41	data input
V _{CC}	42	supply voltage
1D3	43	data input
1D2	44	data input
GND	45	ground (0 V)
1D1	46	data input
1D0	47	data input
1CP	48	clock pulse input (active rising edge)

7. Functional description

7.1 Function table

Table 4: Function table [1]

Operating mode	Input			Internal register	Output nQ0 to nQ7
	nOE	nCP	nDn		
Load and read register	L	↑	l	L	L
	L	↑	h	H	H
Hold	L	NC	X	NC	NC
Disable outputs	H	NC	X	NC	Z
	H	↑	nDn	nDn	Z

- [1] H = HIGH voltage level;
 h = HIGH voltage level one set-up time prior to the HIGH-to-LOW clock transition;
 L = LOW voltage level;
 l = LOW voltage level one set-up time prior to the HIGH-to-LOW clock transition;
 NC = no change;
 X = don't care;
 Z = high-impedance OFF-state;
 ↑ = LOW-to-HIGH clock transition.

8. Limiting values

Table 5: Limiting values

In accordance with the Absolute Maximum Rating System (IEC 60134). Voltages are referenced to GND (ground = 0 V)

Symbol	Parameter	Conditions	Min	Max	Unit
V _{CC}	supply voltage		-0.5	+4.6	V
I _{IK}	input diode current	V _I < 0 V	-50	-	mA
V _I	input voltage		[1] -0.5	+7.0	V
I _{OK}	output diode current	V _O < 0 V	-50	-	mA
V _O	output voltage	output in OFF-state or HIGH-state	[1] -0.5	+7.0	V

Table 5: Limiting values ...continued

In accordance with the Absolute Maximum Rating System (IEC 60134). Voltages are referenced to GND (ground = 0 V)

Symbol	Parameter	Conditions	Min	Max	Unit
I_O	output current	output in LOW-state	-	128	mA
		output in HIGH-state	-	-64	mA
T_{stg}	storage temperature		-65	+150	°C
T_j	junction temperature		[2]	150	°C

[1] The input and output negative voltage ratings may be exceeded if the input and output clamp current ratings are observed.

[2] The performance capability of a high-performance integrated circuit in conjunction with its thermal

9. Recommended operating conditions

Table 6: Recommended operating conditions

Symbol	Parameter	Conditions	Min	Typ	Max	Unit
V_{CC}	supply voltage		2.7	-	3.6	V
V_I	input diode voltage		0	-	5.5	V
V_{IH}	HIGH-level input voltage		2.0	-	-	V
V_{IL}	LOW-level input voltage		-	-	0.8	V
I_{OH}	HIGH-level output current		-	-	-12	mA
I_{OL}	LOW-level output current		-	-	12	mA
$\Delta t/\Delta V$	input transition rise or fall rate	outputs enabled	-	-	10	ns/V
T_{amb}	ambient temperature		-40	-	+85	°C

10. Static characteristics

Table 7: Static characteristics

At recommended operating conditions; voltages are referenced to GND (ground = 0 V).

Symbol	Parameter	Conditions	Min	Typ	Max	Unit	
$T_{amb} = -40\text{ °C to }+85\text{ °C}$ [1]							
V_{IK}	input clamp voltage	$V_{CC} = 2.7\text{ V}; I_{IK} = -18\text{ mA}$	-	-0.85	-1.2	V	
V_{OH}	HIGH-level output voltage	$V_{CC} = 3.0\text{ V}; I_{OH} = -12\text{ mA}$	2.0	-	-	V	
V_{OL}	LOW-level output voltage	$V_{CC} = 3.0\text{ V}; I_{OL} = 12\text{ mA}$	-	-	0.8	V	
V_{RST}	power-up output low voltage	$V_{CC} = 3.6\text{ V}; I_O = 1\text{ mA}; V_I = \text{GND or } V_{CC}$	[2]	0.1	0.55	V	
I_{LI}	input leakage current	control pins	$V_{CC} = 3.6\text{ V}; V_I = V_{CC}\text{ or GND}$	-	0.1	±1	µA
			$V_{CC} = 0\text{ V or } 3.6\text{ V}; V_I = 5.5\text{ V}$	-	0.4	10	µA
	I/O data pins	$V_{CC} = 3.6\text{ V}; V_I = V_{CC}$	-	0.1	1	µA	
		$V_{CC} = 3.6\text{ V}; V_I = 0\text{ V}$	-	-0.4	-5	µA	
I_{OFF}	output off current	$V_{CC} = 0\text{ V}; V_I\text{ or } V_O = 0\text{ V to } 4.5\text{ V}$	-	0.1	±100	µA	

Table 7: Static characteristics ...continued

At recommended operating conditions; voltages are referenced to GND (ground = 0 V).

Symbol	Parameter	Conditions	Min	Typ	Max	Unit
I_{HOLD}	bus hold current D inputs	$V_{\text{CC}} = 3 \text{ V}; V_{\text{I}} = 0.8 \text{ V}$	[4] 75	135	-	μA
		$V_{\text{CC}} = 3 \text{ V}; V_{\text{I}} = 2.0 \text{ V}$	-75	-135	-	μA
		$V_{\text{CC}} = 0 \text{ V to } 3.6 \text{ V}; V_{\text{I}} = 3.6 \text{ V}$	± 500	-	-	μA
I_{EX}	external current into output	output in HIGH-state when $V_{\text{O}} > V_{\text{CC}}$; measured at $V_{\text{O}} = 5.5 \text{ V}$ and $V_{\text{CC}} = 3.0 \text{ V}$	-	50	125	μA
$I_{\text{PU}}, I_{\text{PD}}$	power-up or power-down 3-state output current	$V_{\text{CC}} \leq 1.2 \text{ V}; V_{\text{O}} = 5.0 \text{ V to } V_{\text{CC}}$; $V_{\text{I}} = \text{GND or } V_{\text{CC}}$; nOE and nOE = don't care	[5] -	1	± 100	μA
I_{OZH}	3-state output HIGH current	$V_{\text{CC}} = 3.6 \text{ V}; V_{\text{O}} = 3.0 \text{ V}; V_{\text{I}} = V_{\text{IH}} \text{ or } V_{\text{IL}}$	-	0.5	5	μA
I_{OZL}	3-state output LOW current	$V_{\text{CC}} = 3.6 \text{ V}; V_{\text{O}} = 0.5 \text{ V}; V_{\text{I}} = V_{\text{IH}} \text{ or } V_{\text{IL}}$	-	+0.5	-5	μA
I_{CC}	quiescent supply current	$V_{\text{CC}} = 3.6 \text{ V}; V_{\text{I}} = \text{GND or } V_{\text{CC}};$ $I_{\text{O}} = 0 \text{ A}$	-	0.07	0.12	mA
		outputs HIGH	-	4	6	mA
		outputs disabled	[6] -	0.07	0.12	mA
ΔI_{CC}	additional supply current per input pin	$V_{\text{CC}} = 3 \text{ V to } 3.6 \text{ V};$ one input at $V_{\text{CC}} - 0.6 \text{ V};$ other inputs at V_{CC} or GND	[7] -	0.1	0.2	mA
C_{I}	input capacitance	$V_{\text{I}} = 0 \text{ V or } 3.0 \text{ V}$	-	3	-	pF
C_{O}	output capacitance	outputs disabled; $V_{\text{O}} = 0 \text{ V or } 3.0 \text{ V}$	-	9	-	pF

[1] All typical values are at $V_{\text{CC}} = 3.3 \text{ V}$ and $T_{\text{amb}} = 25 \text{ }^\circ\text{C}$.

[2] For valid test results, data must not be loaded into the flip-flops (or latches) after applying power.

[3] Unused pins at V_{CC} or GND.

[4] This is the bus-hold overdrive current required to force the input to the opposite logic state.

[5] This parameter is valid for any V_{CC} between 0 V and 1.2 V with a transition time of up to 10 ms. From $V_{\text{CC}} = 1.2 \text{ V}$ to $V_{\text{CC}} = 3.3 \text{ V} \pm 0.3 \text{ V}$ a transition time of 100 μs is permitted. This parameter is valid for $T_{\text{amb}} = 25 \text{ }^\circ\text{C}$ only.[6] I_{CC} is measured with outputs pulled to V_{CC} or GND.[7] This is the increase in supply current for each input at the specified voltage level other than V_{CC} or GND.**Table 8: Dynamic characteristics** $G_{\text{ND}} = 0 \text{ V}; t_{\text{r}} = t_{\text{f}} = 2.5 \text{ ns}; C_{\text{L}} = 50 \text{ pF}; R_{\text{L}} = 500 \text{ } \Omega;$ for test circuit see [Figure 10](#).

Symbol	Parameter	Conditions	Min	Typ	Max	Unit
$T_{\text{amb}} = -40 \text{ }^\circ\text{C to } +85 \text{ }^\circ\text{C}$ [1]						
f_{max}	maximum clock frequency	$V_{\text{CC}} = 3.3 \text{ V} \pm 0.3 \text{ V};$ see Figure 6	150	-	-	MHz
t_{PLH}	propagation delay nCP to nQn	see Figure 6	-	-	-	-
		$V_{\text{CC}} = 3.3 \text{ V} \pm 0.3 \text{ V}$	1.5	3.0	5.3	ns
		$V_{\text{CC}} = 2.7 \text{ V}$	-	-	6.2	ns

Table 8: Dynamic characteristics ...continued

$GND = 0\text{ V}$; $t_r = t_f = 2.5\text{ ns}$; $C_L = 50\text{ pF}$; $R_L = 500\ \Omega$; for test circuit see [Figure 10](#).

Symbol	Parameter	Conditions	Min	Typ	Max	Unit
t_{PHL}	propagation delay nCP to nQn	see Figure 6				
		$V_{CC} = 3.3\text{ V} \pm 0.3\text{ V}$	1.5	3.0	4.9	ns
		$V_{CC} = 2.7\text{ V}$	-	-	5.1	ns
t_{PZH}	output enable time to HIGH-level	see Figure 7				
		$V_{CC} = 3.3\text{ V} \pm 0.3\text{ V}$	1.5	3.5	5.6	ns
		$V_{CC} = 2.7\text{ V}$	-	-	6.9	ns
t_{PZL}	output enable time to LOW-level	see Figure 8				
		$V_{CC} = 3.3\text{ V} \pm 0.3\text{ V}$	1.5	3.2	4.9	ns
		$V_{CC} = 2.7\text{ V}$	-	-	6.0	ns
t_{PHZ}	output disable time from HIGH-level	see Figure 7				
		$V_{CC} = 3.3\text{ V} \pm 0.3\text{ V}$	1.5	3.5	5.4	ns
		$V_{CC} = 2.7\text{ V}$	-	-	5.7	ns
t_{PLZ}	output disable time from LOW-level	see Figure 8				
		$V_{CC} = 3.3\text{ V} \pm 0.3\text{ V}$	1.5	3.2	5.0	ns
		$V_{CC} = 2.7\text{ V}$	-	-	5.1	ns

[1] All typical values are at $V_{CC} = 3.3\text{ V}$ and $T_{amb} = 25\text{ }^\circ\text{C}$.

Table 9: Dynamic characteristics set-up requirements

$GND = 0\text{ V}$; $t_r = t_f = 2.5\text{ ns}$; $C_L = 50\text{ pF}$; $R_L = 500\ \Omega$.

Symbol	Parameter	Conditions	Min	Typ	Max	Unit
$T_{amb} = -40\text{ }^\circ\text{C}$ to $+85\text{ }^\circ\text{C}$ [1]						
$t_{su(H)}$, $t_{su(L)}$	set-up time nDn to nCP	see Figure 9				
		$V_{CC} = 3.3\text{ V} \pm 0.3\text{ V}$	2.0	0.7	-	ns
		$V_{CC} = 2.7\text{ V}$	2.0	-	-	ns
$t_{h(H)}$, $t_{h(L)}$	hold time nDn to nCP	see Figure 9				
		$V_{CC} = 3.3\text{ V} \pm 0.3\text{ V}$	0.8	0	-	ns
		$V_{CC} = 2.7\text{ V}$	0.1	-	-	ns
$t_{W(H)}$	nCP pulse width HIGH	see Figure 6				
		$V_{CC} = 3.3\text{ V} \pm 0.3\text{ V}$	1.5	0.6	-	ns
		$V_{CC} = 2.7\text{ V}$	1.5	-	-	ns
$t_{W(L)}$	nCP pulse width LOW	see Figure 6				
		$V_{CC} = 3.3\text{ V} \pm 0.3\text{ V}$	3.0	1.6	-	ns
		$V_{CC} = 2.7\text{ V}$	3.0	-	-	ns

[1] All typical values are at $V_{CC} = 3.3\text{ V}$ and $T_{amb} = 25\text{ }^\circ\text{C}$.

12. Waveforms

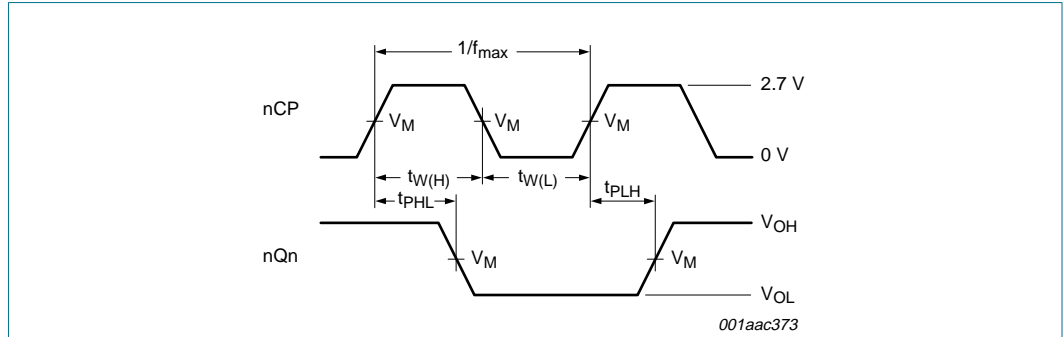

$V_M = 1.5\text{ V}$; $V_I = \text{GND to } 3.0\text{ V}$.
 V_{OL} and V_{OH} are typical voltage output drop that occur with the output load.

Fig 6. Propagation delay clock input to output, clock pulse width and maximum clock frequency

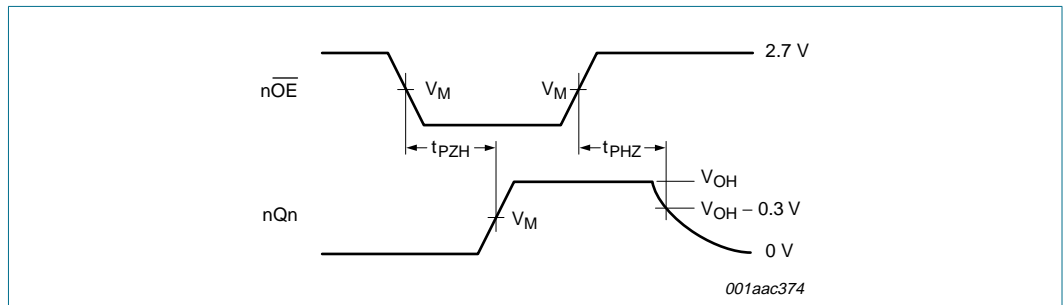

$V_M = 1.5\text{ V}$; $V_I = \text{GND to } 3.0\text{ V}$.
 V_{OH} is typical voltage output drop that occur with the output load.

Fig 7. 3-state output enable time to HIGH-level and output disable time from HIGH-level

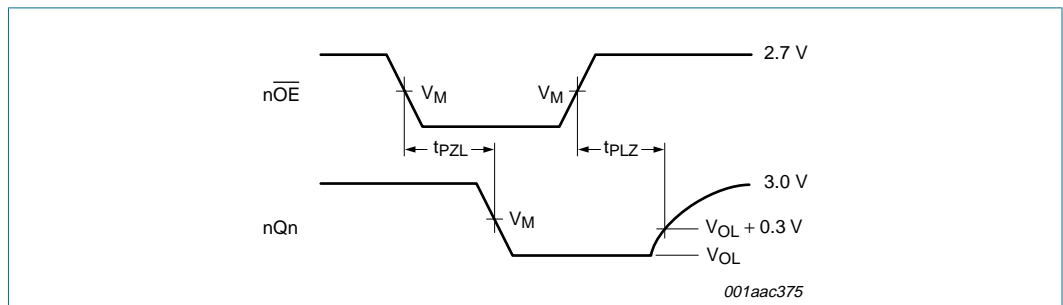

$V_M = 1.5\text{ V}$; $V_I = \text{GND to } 3.0\text{ V}$.
 V_{OL} is typical voltage output drop that occur with the output load.

Fig 8. 3-state output enable time to LOW-level and output disable time from LOW-level

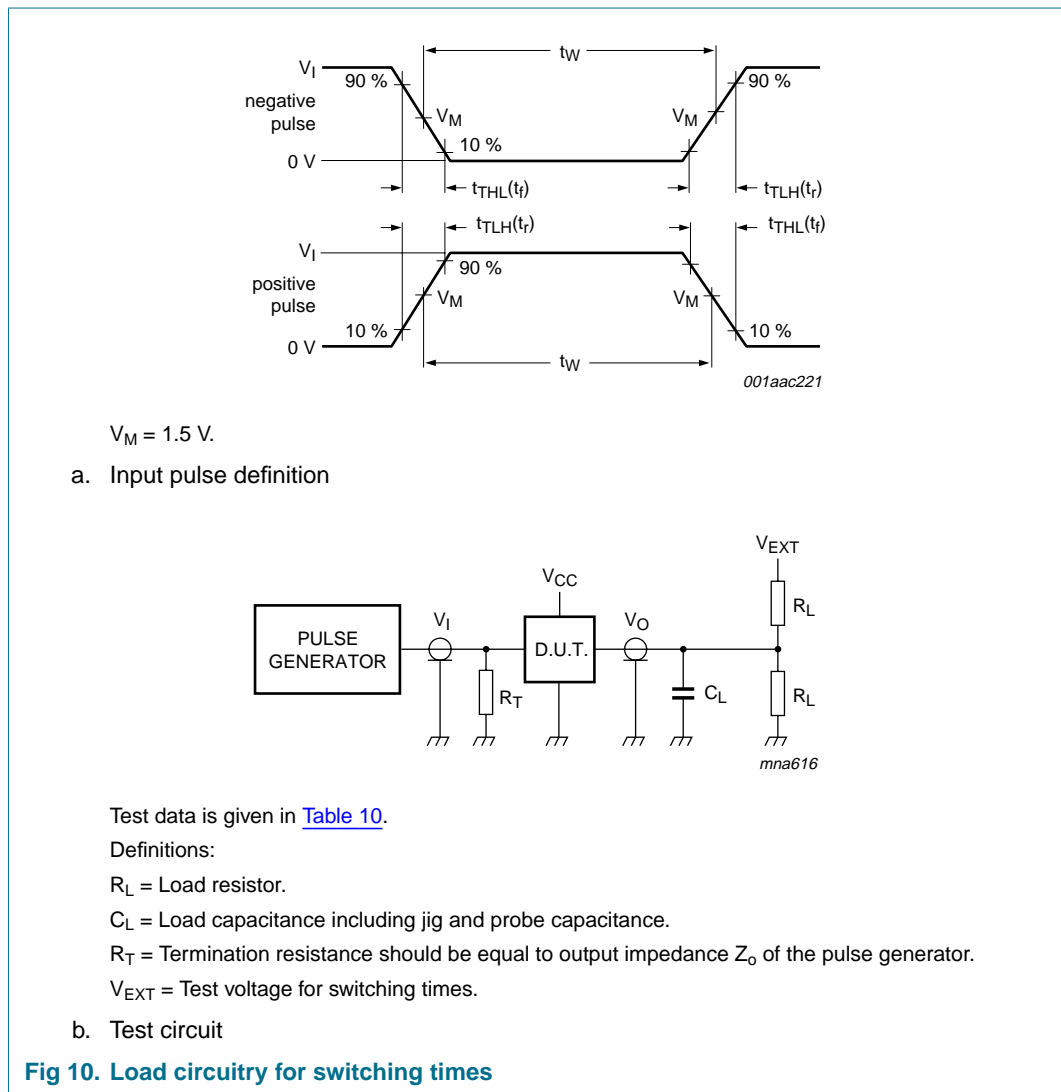
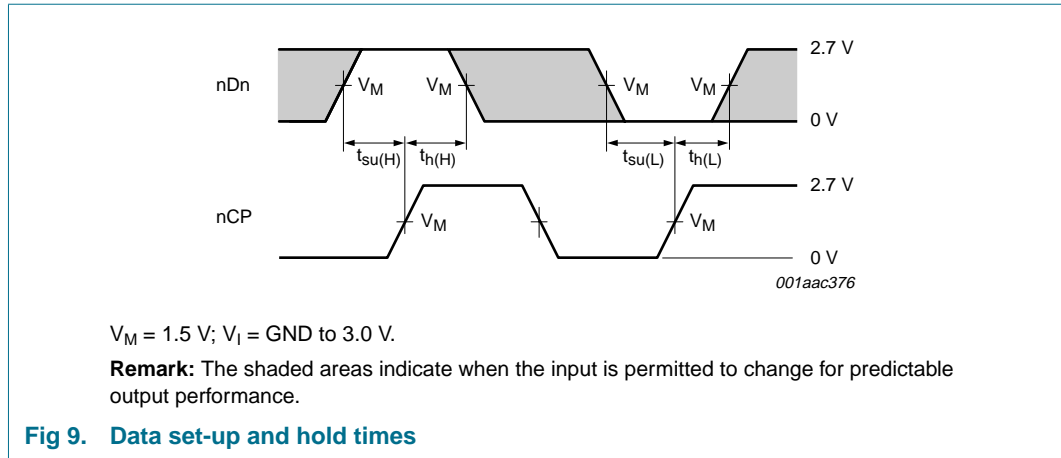

Table 10: Test data

Supply voltage	Repetition rate	Input		Load		V _{EXT}		
		t _w	t _r , t _f	C _L	R _L	t _{PHZ} , t _{PZH}	t _{PLZ} , t _{PZL}	t _{PLH} , t _{PHL}
2.7 V	≤ 10 MHz	500 ns	≤ 2.5 ns	50 pF	500 Ω	GND	6 V	open

13. Package outline

TSSOP48: plastic thin shrink small outline package; 48 leads; body width 6.1 mm

SOT362-1

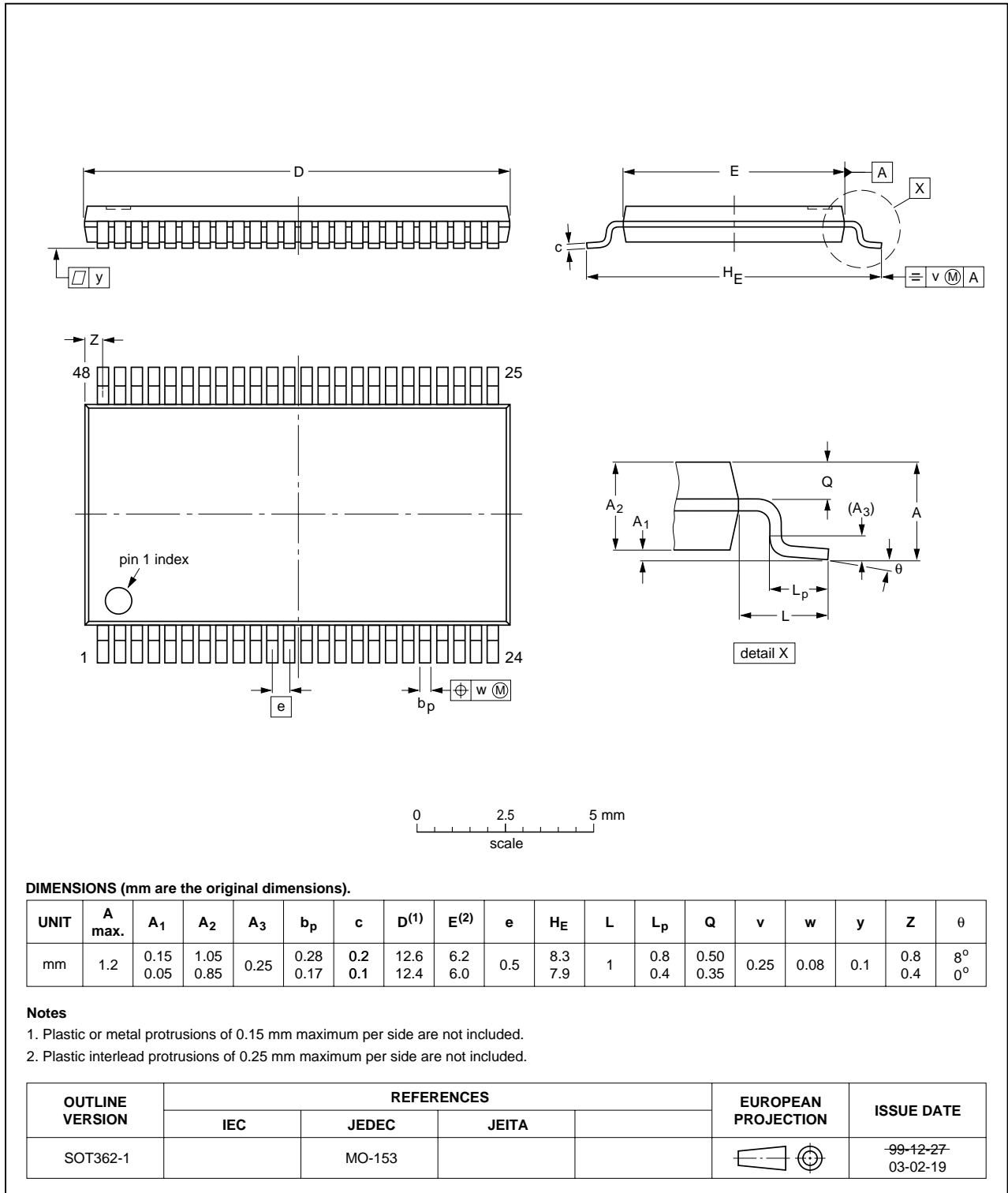

Fig 11. Package outline SOT362-1 (TSSOP48)

SSOP48: plastic shrink small outline package; 48 leads; body width 7.5 mm

SOT370-1

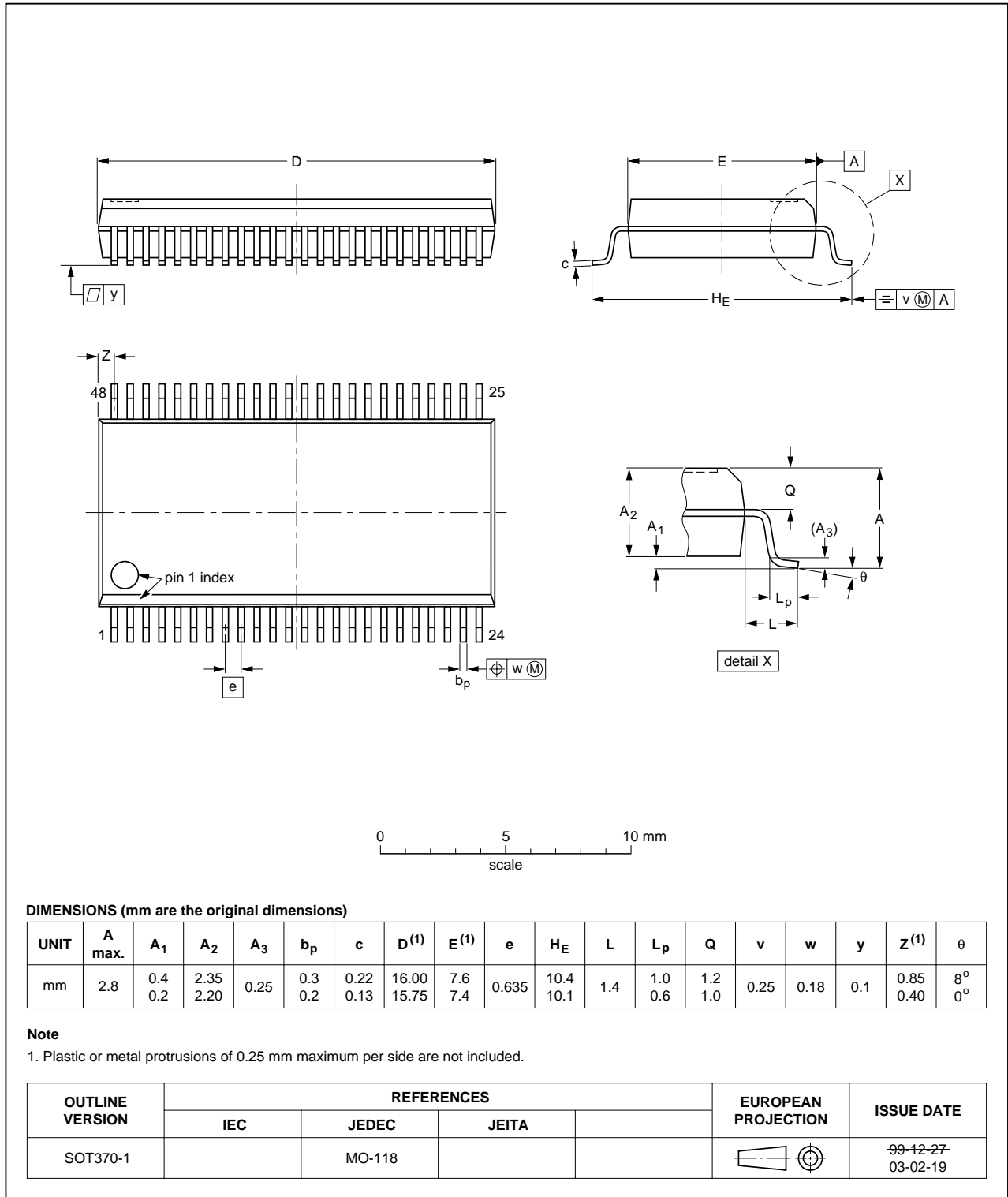

Fig 12. Package outline SOT370-1 (SSOP48)

14. Revision history

Table 11: Revision history

Document ID	Release date	Data sheet status	Change notice	Doc. number	Supersedes
74LVT162374_3	20050117	Product data sheet	-	9397 750 14401	74LVT162374_2
Modifications:	<ul style="list-style-type: none"> The format of this data sheet is redesigned to comply with the current presentation and information standard of Philips Semiconductors. Section 2 "Features": Changed JEDEC Std 17 into JESD78 Table 1 "Quick reference data": Changed t_{PLH} and t_{PHL} propagation delays nCP to nQn to 3.0 ns Table 9 "Dynamic characteristics set-up requirements": Changed the minimum values of $t_{h(H)}$ and $t_{h(L)}$ hold time nDn to nCP to 0.8 ns 				
74LVT162374_2	20040922	Product specification	-	9397 750 14087	74LVT162374_1
74LVT162374_1	19990923	Product specification	-	9397 750 06508	-

15. Data sheet status

Level	Data sheet status ^[1]	Product status ^[2] ^[3]	Definition
I	Objective data	Development	This data sheet contains data from the objective specification for product development. Philips Semiconductors reserves the right to change the specification in any manner without notice.
II	Preliminary data	Qualification	This data sheet contains data from the preliminary specification. Supplementary data will be published at a later date. Philips Semiconductors reserves the right to change the specification without notice, in order to improve the design and supply the best possible product.
III	Product data	Production	This data sheet contains data from the product specification. Philips Semiconductors reserves the right to make changes at any time in order to improve the design, manufacturing and supply. Relevant changes will be communicated via a Customer Product/Process Change Notification (CPCN).

[1] Please consult the most recently issued data sheet before initiating or completing a design.

[2] The product status of the device(s) described in this data sheet may have changed since this data sheet was published. The latest information is available on the Internet at URL <http://www.semiconductors.philips.com>.

[3] For data sheets describing multiple type numbers, the highest-level product status determines the data sheet status.

16. Definitions

Short-form specification — The data in a short-form specification is extracted from a full data sheet with the same type number and title. For detailed information see the relevant data sheet or data handbook.

Limiting values definition — Limiting values given are in accordance with the Absolute Maximum Rating System (IEC 60134). Stress above one or more of the limiting values may cause permanent damage to the device. These are stress ratings only and operation of the device at these or at any other conditions above those given in the Characteristics sections of the specification is not implied. Exposure to limiting values for extended periods may affect device reliability.

Application information — Applications that are described herein for any of these products are for illustrative purposes only. Philips Semiconductors make no representation or warranty that such applications will be suitable for the specified use without further testing or modification.

17. Disclaimers

Life support — These products are not designed for use in life support appliances, devices, or systems where malfunction of these products can reasonably be expected to result in personal injury. Philips Semiconductors customers using or selling these products for use in such applications do so at their own risk and agree to fully indemnify Philips Semiconductors for any damages resulting from such application.

Right to make changes — Philips Semiconductors reserves the right to make changes in the products - including circuits, standard cells, and/or software - described or contained herein in order to improve design and/or performance. When the product is in full production (status 'Production'), relevant changes will be communicated via a Customer Product/Process Change Notification (CPCN). Philips Semiconductors assumes no responsibility or liability for the use of any of these products, conveys no license or title under any patent, copyright, or mask work right to these products, and makes no representations or warranties that these products are free from patent, copyright, or mask work right infringement, unless otherwise specified.

18. Contact information

For additional information, please visit: <http://www.semiconductors.philips.com>

For sales office addresses, send an email to: sales.addresses@www.semiconductors.philips.com

19. Contents

1	General description	1
2	Features	1
3	Quick reference data	2
4	Ordering information	2
5	Functional diagram	3
6	Pinning information	4
6.1	Pinning	4
6.2	Pin description	5
7	Functional description	6
7.1	Function table	6
8	Limiting values	6
9	Recommended operating conditions	7
10	Static characteristics	7
11	Dynamic characteristics	8
12	Waveforms	10
13	Package outline	13
14	Revision history	15
15	Data sheet status	16
16	Definitions	16
17	Disclaimers	16
18	Contact information	16



© Koninklijke Philips Electronics N.V. 2005

All rights are reserved. Reproduction in whole or in part is prohibited without the prior written consent of the copyright owner. The information presented in this document does not form part of any quotation or contract, is believed to be accurate and reliable and may be changed without notice. No liability will be accepted by the publisher for any consequence of its use. Publication thereof does not convey nor imply any license under patent- or other industrial or intellectual property rights.

Date of release: 17 January 2005
Document number: 9397 750 14401

Published in The Netherlands