

74LVT244A-Q100; 74LVTH244A-Q100

3.3 V octal buffer/line driver; 3-state

Rev. 1 — 22 April 2013

Product data sheet

1. General description

The 74LVT244A-Q100; 74LVTH244A-Q100 is a high-performance BiCMOS product designed for V_{CC} operation at 3.3 V.

This device is an octal buffer that is ideal for driving bus lines. The device features two output enables (1OE, 2OE), each controlling four of the 3-state outputs.

This product has been qualified to the Automotive Electronics Council (AEC) standard Q100 (Grade 3) and is suitable for use in automotive applications.

2. Features and benefits

- Automotive product qualification in accordance with AEC-Q100 (Grade 3)
 - ◆ Specified from $-40\text{ }^{\circ}\text{C}$ to $+85\text{ }^{\circ}\text{C}$
- Octal bus interface
- 3-state buffers
- Output capability: +64 mA and -32 mA
- TTL input and output switching levels
- Input and output interface capability to systems at 5 V supply
- Bus hold data inputs eliminate need for external pull-up resistors to hold unused inputs
- Live insertion and extraction permitted
- Power-up 3-state
- No bus current loading when output is tied to 5 V bus
- Latch-up protection
 - ◆ JESD78 Class II exceeds 500 mA
- ESD protection:
 - ◆ MIL-STD-883, method 3015 exceeds 2000 V
 - ◆ HBM JESD22-A114F exceeds 2000 V
 - ◆ MM JESD22-A115-A exceeds 200 V ($C = 200\text{ pF}$, $R = 0\ \Omega$)



3. Ordering information

Table 1. Ordering information

Type number	Package			Version
	Temperature range	Name	Description	
74LVT244AD-Q100 74LVTH244AD-Q100	-40 °C to +85 °C	SO20	plastic small outline package; 20 leads; body width 7.5 mm	SOT163-1
74LVT244APW-Q100 74LVTH244APW-Q100	-40 °C to +85 °C	TSSOP20	plastic thin shrink small outline package; 20 leads; body width 4.4 mm	SOT360-1
74LVT244ABQ-Q100 74LVTH244ABQ-Q100	-40 °C to +85 °C	DHVQFN20	plastic dual in-line compatible thermal enhanced very thin quad flat package; no leads; 20 terminals; body 2.5 × 4.5 × 0.85 mm	SOT764-1

4. Functional diagram

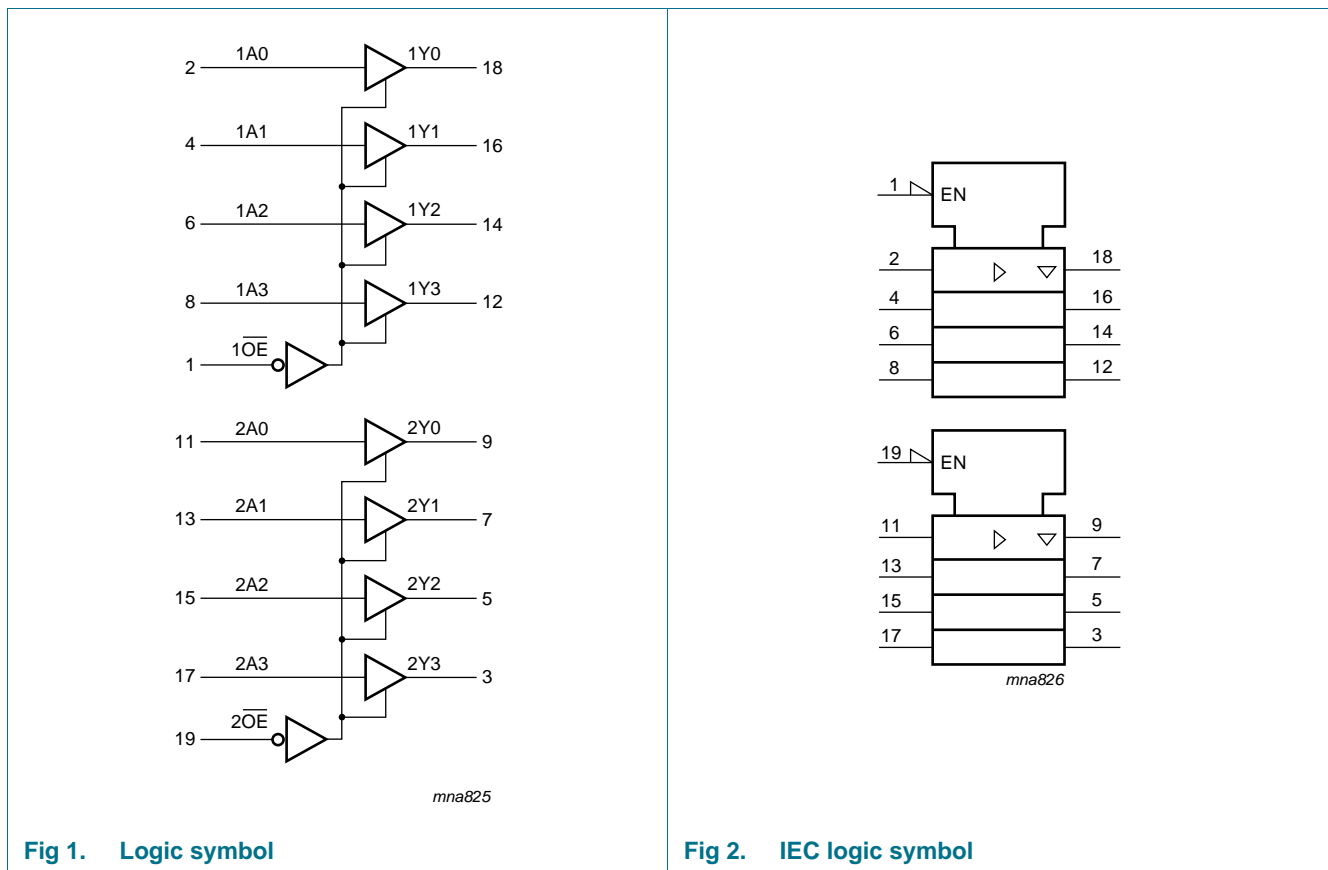

5. Pinning information

5.1 Pinning

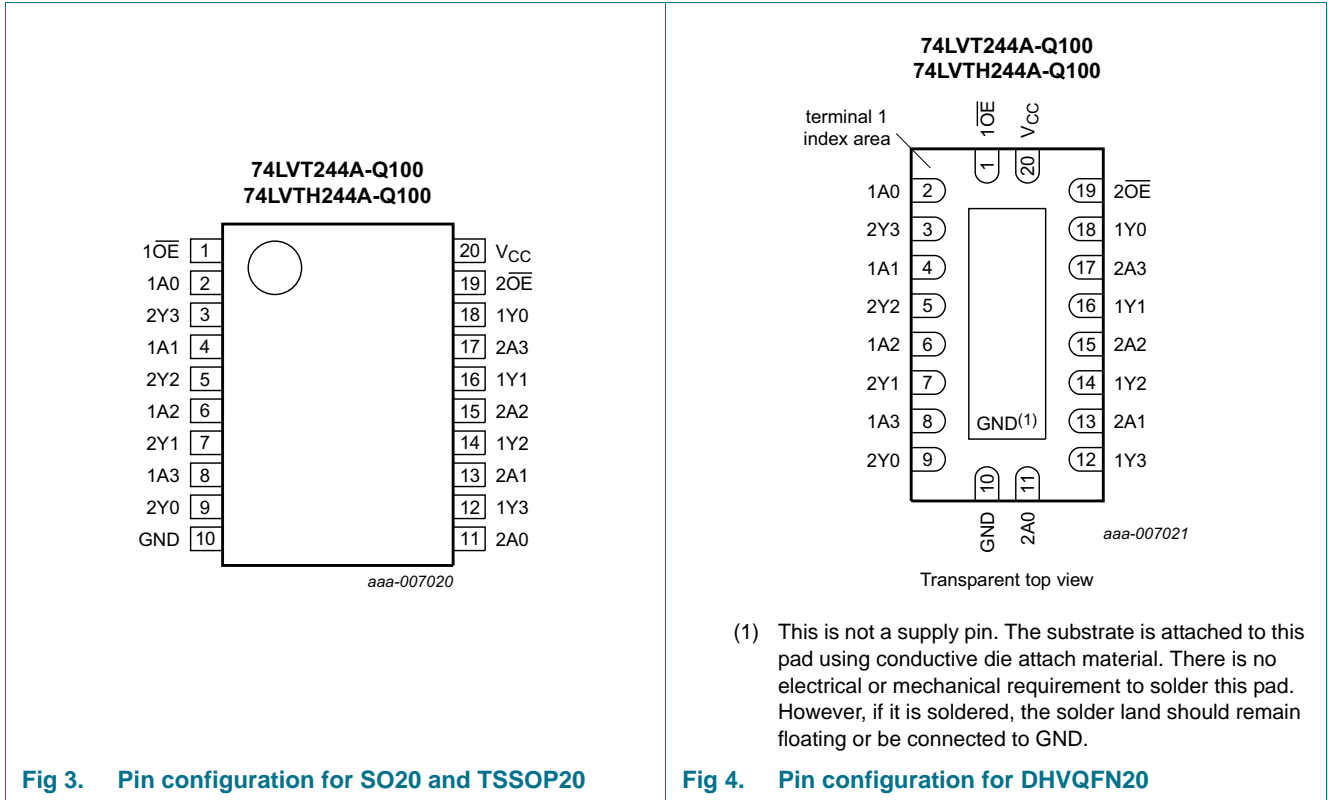

5.2 Pin description

Table 2. Pin description

Symbol	Pin	Description
1OE, 2OE	1, 19	output enable input (active low)
1A0, 1A1, 1A2, 1A3	2, 4, 6, 8	data input
2Y0, 2Y1, 2Y2, 2Y3	9, 7, 5, 3	data output
GND	10	ground (0 V)
2A0, 2A1, 2A2, 2A3	11, 13, 15, 17	data input
1Y0, 1Y1, 1Y2, 1Y3	18, 16, 14, 12	data output
VCC	20	supply voltage

6. Functional description

6.1 Function table

Table 3. Function table [1]

Control	Input	Output
nOE	nAn	nYn
L	L	L
	H	H
H	X	Z

[1] H = HIGH voltage level; L = LOW voltage level; X = don't care; Z = high-impedance OFF-state.

7. Limiting values

Table 4. Limiting values

In accordance with the Absolute Maximum Rating System (IEC 60134). Voltages are referenced to GND (ground = 0 V).

Symbol	Parameter	Conditions	Min	Max	Unit
V_{CC}	supply voltage		-0.5	+4.6	V
V_I	input voltage		[1] -0.5	+7.0	V
V_O	output voltage	output in OFF-state or HIGH-state	[1] -0.5	+7.0	V
I_{IK}	input clamping current	$V_I < 0$ V	-	-50	mA
I_{OK}	output clamping current	$V_O < 0$ V	-	-50	mA
I_O	output current	output in LOW-state	-	128	mA
		output in HIGH-state	-	-64	mA
T_{stg}	storage temperature		-65	+150	°C
T_j	junction temperature		[2] -	150	°C
P_{tot}	total power dissipation	$T_{amb} = -40$ to $+85$ °C	[3]	500	mW

[1] The input and output negative voltage ratings may be exceeded if the input and output clamp current ratings are observed.

[2] The performance capability of a high-performance integrated circuit in conjunction with its thermal environment can create junction temperatures which are detrimental to reliability.

[3] For SO20 package: above 70 °C derate linearly with 8 mW/K.
 For TSSOP20 package: above 60 °C derate linearly with 5.5 mW/K.
 For DHVQFN20 package: above 60 °C derate linearly with 4.5 mW/K.

8. Recommended operating conditions

Table 5. Operating conditions

Symbol	Parameter	Conditions	Min	Typ	Max	Unit
V_{CC}	supply voltage		2.7	-	3.6	V
V_I	input voltage		0	-	5.5	V
I_{OH}	HIGH-level output current		-	-	-32	mA

Table 5. Operating conditions ...continued

Symbol	Parameter	Conditions	Min	Typ	Max	Unit
I _{OL}	LOW-level output current	none	-	-	32	mA
		current duty cycle ≤ 50 %; f _i ≥ 1 kHz	-	-	64	mA
T _{amb}	ambient temperature	in free-air	-40	-	+85	°C
Δt/ΔV	input transition rise and fall rate	outputs enabled	-	-	10	ns/V

9. Static characteristics

Table 6. Static characteristics

At recommended operating conditions; voltages are referenced to GND (ground = 0 V).

Symbol	Parameter	Conditions	Min	Typ	Max	Unit
T_{amb} = -40 °C to +85 °C [1]						
V _{IK}	input clamping voltage	V _{CC} = 2.7 V; I _{IK} = -18 mA	-1.2	-0.9	-	V
V _{IH}	HIGH-level input voltage		2.0	-	-	V
V _{IL}	LOW-level input voltage		-	-	0.8	V
V _{OH}	HIGH-level output voltage	V _{CC} = 2.7 V to 3.6 V; I _{OH} = -100 μA	V _{CC} - 0.2	V _{CC} - 0.1	-	V
		V _{CC} = 2.7 V to 3.6 V; I _{OH} = -8 mA	2.4	2.5	-	V
		V _{CC} = 3.0 V; I _{OH} = -32 mA	2.0	2.2	-	V
V _{OL}	LOW-level output voltage	V _{CC} = 2.7 V; I _{OL} = 100 μA	-	0.1	0.2	V
		V _{CC} = 2.7 V; I _{OL} = 24 mA	-	0.3	0.5	V
		V _{CC} = 3.0 V; I _{OL} = 16 mA	-	0.25	0.4	V
		V _{CC} = 3.0 V; I _{OL} = 32 mA	-	0.3	0.5	V
		V _{CC} = 3.0 V; I _{OL} = 64 mA	-	0.4	0.55	V
I _I	input leakage current	all input pins				
		V _{CC} = 0 V or 3.6 V; V _I = 5.5 V	-	0.1	10	μA
		control pins				
		V _{CC} = 3.6 V; V _I = V _{CC} or GND	-	±0.1	±1	μA
		data pins [2]				
		V _{CC} = 3.6 V; V _I = V _{CC}	-	0.1	1	μA
		V _{CC} = 3.6 V; V _I = 0 V	-5	-1	-	μA
I _{OFF}	power-off leakage current	V _{CC} = 0 V; V _I or V _O = 0 V to 4.5 V	-	1	±100	μA
I _{BHL}	bus hold LOW current	V _{CC} = 3 V; V _I = 0.8 V [3]	75	150	-	μA
I _{BHH}	bus hold HIGH current	V _{CC} = 3 V; V _I = 2.0 V	-	-150	-75	μA
I _{BHLO}	bus hold LOW overdrive current	nAn input; V _{CC} = 0 V to 3.6 V; V _I = 3.6 V	500	-	-	μA
I _{BHHO}	bus hold HIGH overdrive current	nAn input; V _{CC} = 0 V to 3.6 V; V _I = 3.6 V	-	-	-500	μA
I _{LO}	output leakage current	nYn output in HIGH-state when V _O > V _{CC} ; V _O = 5.5 V; V _{CC} = 3.0 V	-	60	125	μA
I _{O(pu/pd)}	power-up/power-down output current	V _{CC} ≤ 1.2 V; V _O = 0.5 V to V _{CC} ; V _I = GND or V _{CC} ; nOE = don't care [4]	-	±1	±100	μA

Table 6. Static characteristics ...continued

At recommended operating conditions; voltages are referenced to GND (ground = 0 V).

Symbol	Parameter	Conditions	Min	Typ	Max	Unit	
I _{OZ}	OFF-state output current	V _{CC} = 3.6 V; V _I = V _{IH} or V _{IL}					
		V _O = 3.0 V	-	1	5	μA	
		V _O = 0.5 V	-5	-1	-	μA	
I _{CC}	supply current	V _{CC} = 3.6 V; V _I = GND or V _{CC} ; I _O = 0 A					
		output HIGH	-	0.13	0.19	mA	
		output LOW	-	3	12	mA	
		outputs disabled	[5]	-	0.13	0.19	mA
ΔI _{CC}	additional supply current	per input pin; V _{CC} = 3.0 V to 3.6 V; one input at V _{CC} - 0.6 V and other inputs at V _{CC} or GND	[6]	-	0.1	0.2	mA
C _I	input capacitance	V _I = 0 V or 3.0 V	-	4	-	pF	
C _O	output capacitance	outputs disabled; V _O = 0 V or 3.0 V	-	8	-	pF	

[1] All typical values are at T_{amb} = 25 °C.

[2] Unused pins at V_{CC} or GND.

[3] This is the bus hold overdrive current required to force the input to the opposite logic state.

[4] This parameter is valid for any V_{CC} between 0 V and 1.2 V with a transition time of up to 10 ms. From V_{CC} = 1.2 V to V_{CC} = 3.3 V ± 0.3 V a transition time of 100 μs is permitted. This parameter is valid for T_{amb} = 25 °C only.

[5] I_{CC} is measured with outputs pulled to V_{CC} or GND.

[6] This is the increase in supply current for each input at the specified voltage level other than V_{CC} or GND.

10. Dynamic characteristics

Table 7. Dynamic characteristics

Voltages are referenced to GND (ground = 0 V); for test circuit see [Figure 7](#).

Symbol	Parameter	Conditions	Min	Typ	Max	Unit
T_{amb} = -40 °C to +85 °C [1]						
t _{PLH}	LOW to HIGH propagation delay	nAn to nYn; see Figure 5				
		V _{CC} = 2.7 V	-	-	5.0	ns
		V _{CC} = 3.0 V to 3.6 V	1	2.5	4.1	ns
t _{PHL}	HIGH to LOW propagation delay	nAn to nYn; see Figure 5				
		V _{CC} = 2.7 V	-	-	5.1	ns
		V _{CC} = 3.0 V to 3.6 V	1	2.6	4.1	ns
t _{PZH}	OFF-state to HIGH propagation delay	see Figure 6				
		V _{CC} = 2.7 V	-	-	6.3	ns
		V _{CC} = 3.0 V to 3.6 V	1	3.2	5.2	ns
t _{PZL}	OFF-state to LOW propagation delay	see Figure 6				
		V _{CC} = 2.7 V	-	-	6.7	ns
		V _{CC} = 3.0 V to 3.6 V	1.1	3.1	5.2	ns
t _{PHZ}	HIGH to OFF-state propagation delay	see Figure 6				
		V _{CC} = 2.7 V	-	-	6.3	ns
		V _{CC} = 3.0 V to 3.6 V	1.9	3.3	5.6	ns

Table 7. Dynamic characteristics ...continued
 Voltages are referenced to GND (ground = 0 V); for test circuit see [Figure 7](#).

Symbol	Parameter	Conditions	Min	Typ	Max	Unit
t _{PLZ}	LOW to OFF-state propagation delay	see Figure 6				
		V _{CC} = 2.7 V	-	-	5.6	ns
		V _{CC} = 3.0 V to 3.6 V	1.8	3.3	5.1	ns

[1] All typical values are at V_{CC} = 3.3 V and T_{amb} = 25 °C.

11. Waveforms

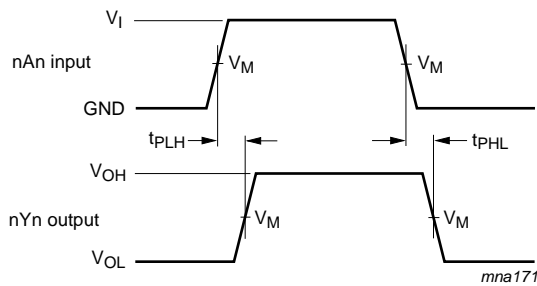

Measurement points are given in [Table 8](#).
 V_{OL} and V_{OH} are typical voltage output levels that occur with the output load.

Fig 5. Propagation delay input (nAn) to output (nYn) propagation delays

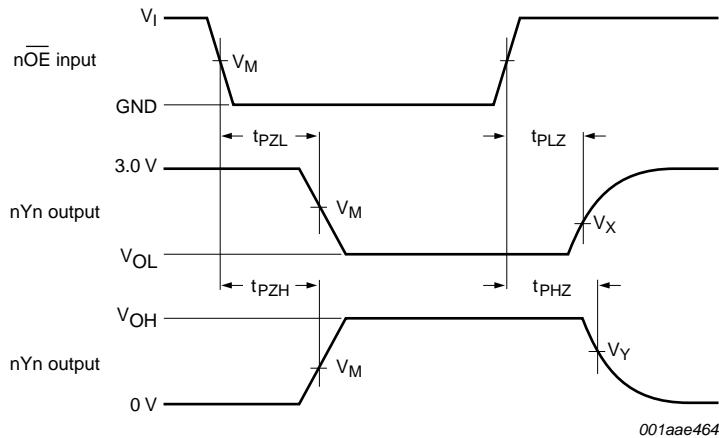

Measurement points are given in [Table 8](#).
 V_{OL} and V_{OH} are typical voltage output levels that occur with the output load.

Fig 6. 3-state output enable and disable times

Table 8. Measurement points

Input	Output		
V _M	V _M	V _X	V _Y
1.5 V	1.5 V	V _{OL} + 0.3 V	V _{OH} - 0.3 V

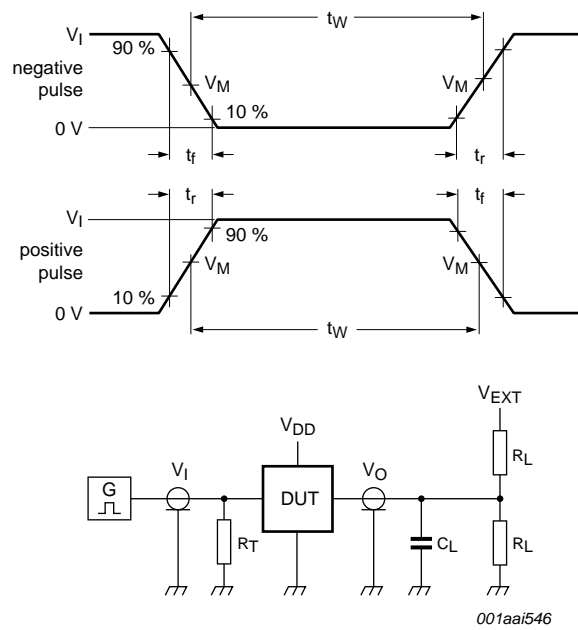

Test data is given in [Table 9](#).

Definitions test circuit:

R_L = Load resistance.

C_L = Load capacitance including jig and probe capacitance.

R_T = Termination resistance should be equal to output impedance Z_o of the pulse generator.

V_{EXT} = Test voltage for switching times.

Fig 7. Test circuit for measuring switching times

Table 9. Test data

Input				Load		V_{EXT}		
V_I	f_i	t_W	t_r, t_f	C_L	R_L	t_{PHZ}, t_{PZH}	t_{PLZ}, t_{PZL}	t_{PLH}, t_{PHL}
2.7 V	≤ 10 MHz	500 ns	≤ 2.5 ns	50 pF	500 Ω	GND	6 V	open

12. Package outline

SO20: plastic small outline package; 20 leads; body width 7.5 mm

SOT163-1

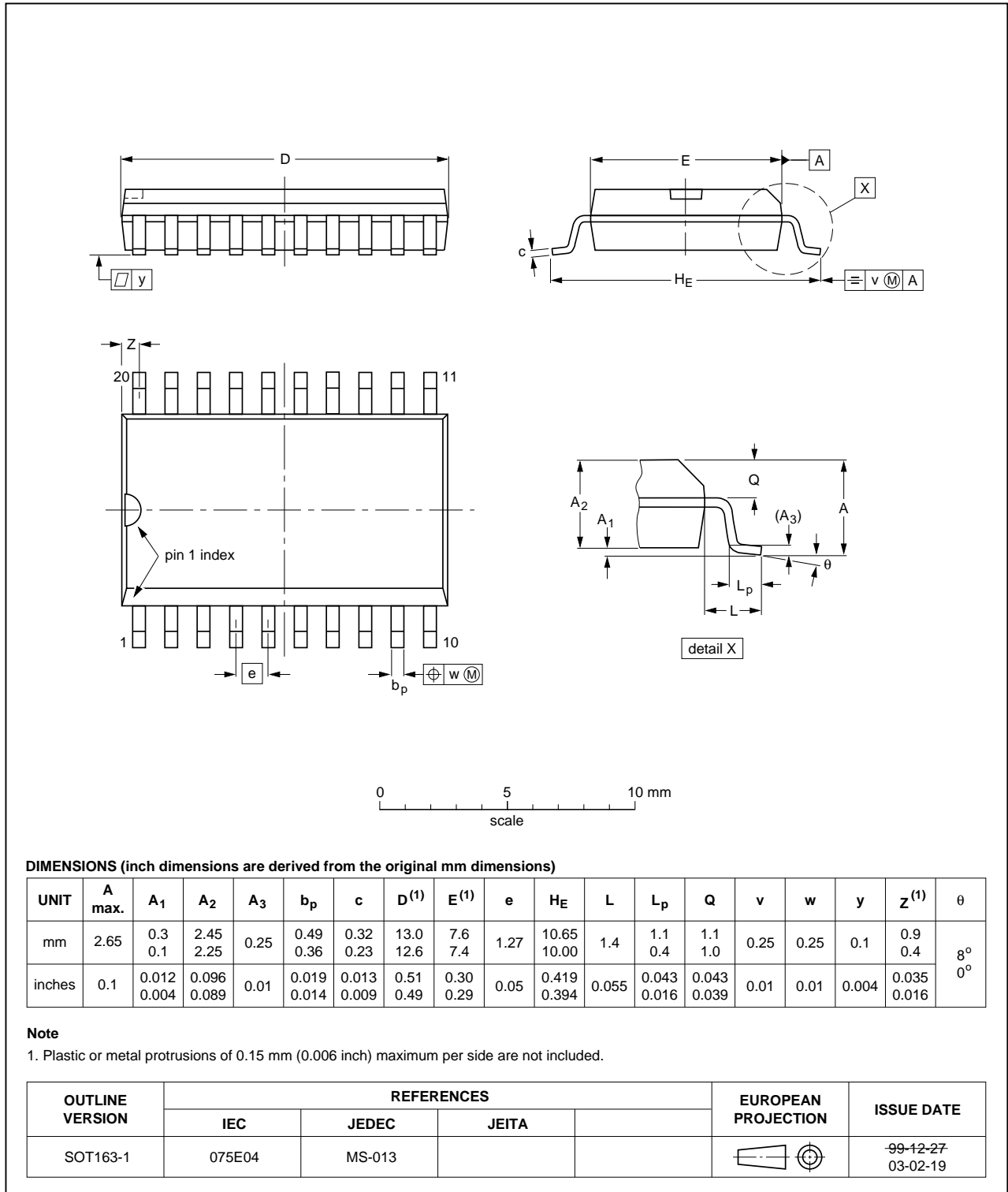

Fig 8. Package outline SOT163-1 (SO20)

TSSOP20: plastic thin shrink small outline package; 20 leads; body width 4.4 mm

SOT360-1

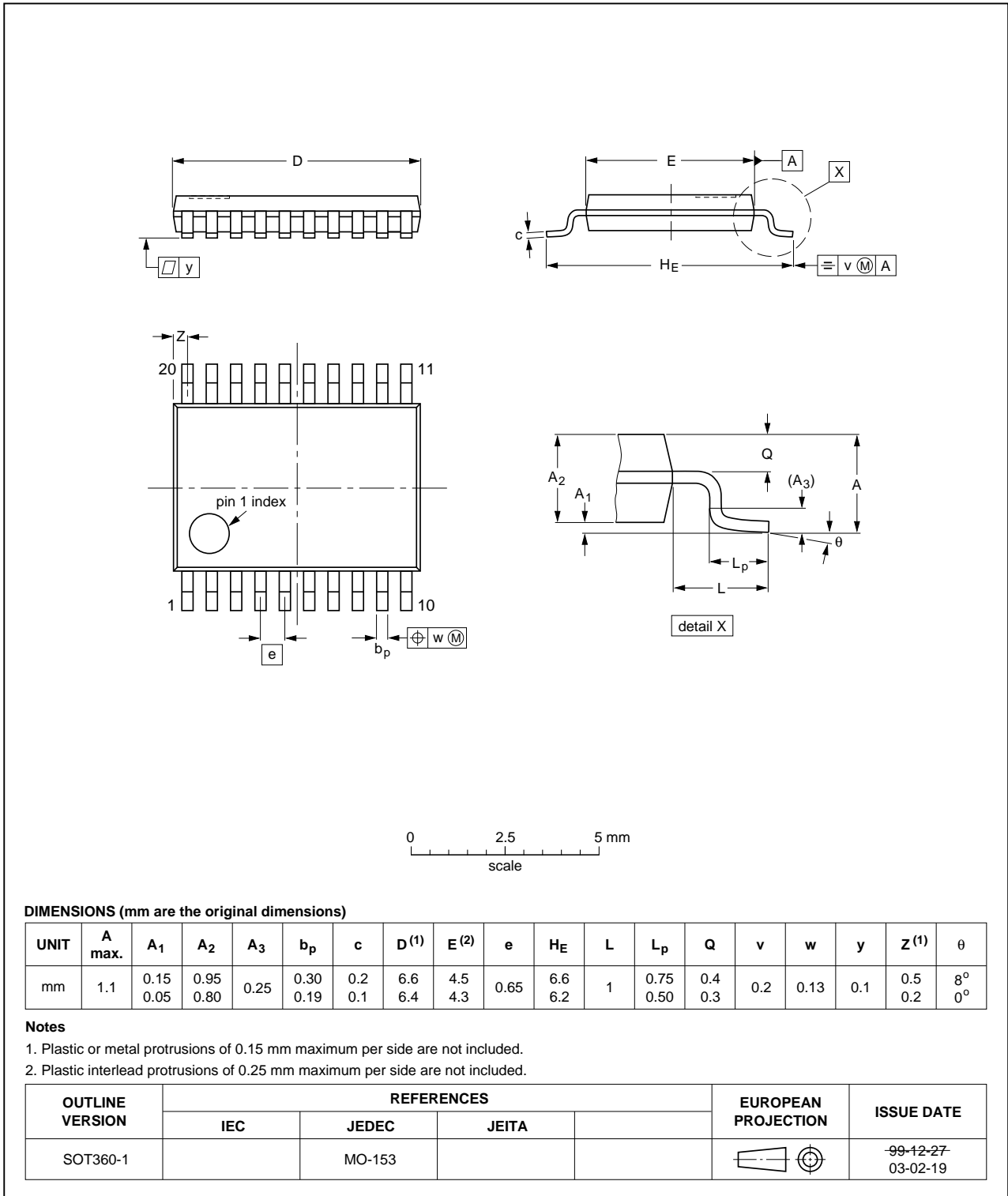

Fig 9. Package outline SOT360-1 (TSSOP20)

DHVQFN20: plastic dual in-line compatible thermal enhanced very thin quad flat package; no leads; 20 terminals; body 2.5 x 4.5 x 0.85 mm

SOT764-1

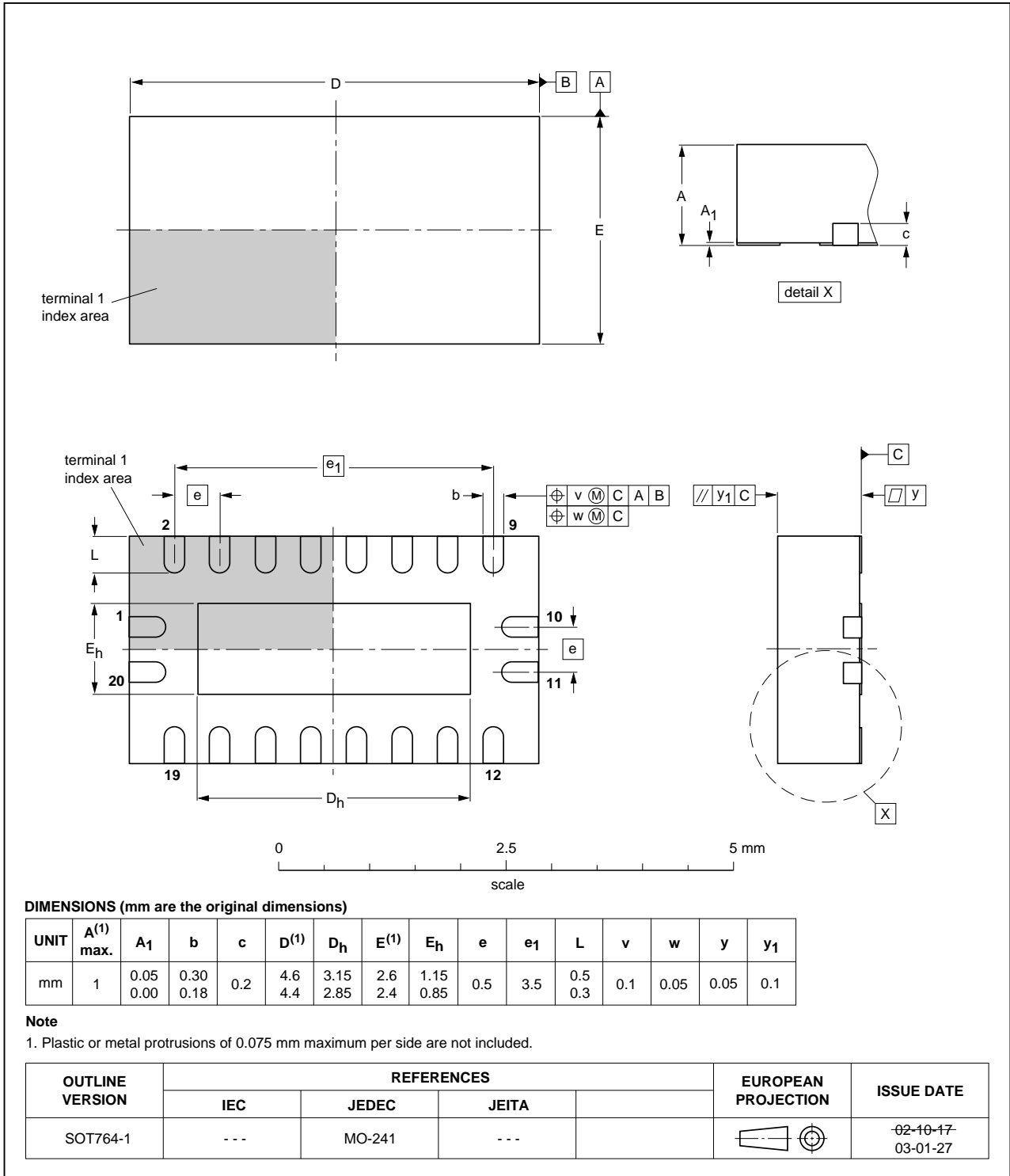

Fig 10. Package outline SOT764-1 (DHVQFN20)

13. Abbreviations

Table 10. Abbreviations

Acronym	Description
BiCMOS	Bi-polar Complementary Metal Oxide Semiconductor
DUT	Device Under Test
ESD	ElectroStatic Discharge
HBM	Human Body Model
MM	Machine Model
MIL	Military
TTL	Transistor-Transistor Logic

14. Revision history

Table 11. Revision history

Document ID	Release date	Data sheet status	Change notice	Supersedes
74LVT_LVTH244A_Q100 v.1	20130422	Product data sheet	-	-

15. Legal information

15.1 Data sheet status

Document status ^{[1][2]}	Product status ^[3]	Definition
Objective [short] data sheet	Development	This document contains data from the objective specification for product development.
Preliminary [short] data sheet	Qualification	This document contains data from the preliminary specification.
Product [short] data sheet	Production	This document contains the product specification.

[1] Please consult the most recently issued document before initiating or completing a design.

[2] The term 'short data sheet' is explained in section "Definitions".

[3] The product status of device(s) described in this document may have changed since this document was published and may differ in case of multiple devices. The latest product status information is available on the Internet at URL <http://www.nxp.com>.

15.2 Definitions

Draft — The document is a draft version only. The content is still under internal review and subject to formal approval, which may result in modifications or additions. NXP Semiconductors does not give any representations or warranties as to the accuracy or completeness of information included herein and shall have no liability for the consequences of use of such information.

Short data sheet — A short data sheet is an extract from a full data sheet with the same product type number(s) and title. A short data sheet is intended for quick reference only and should not be relied upon to contain detailed and full information. For detailed and full information see the relevant full data sheet, which is available on request via the local NXP Semiconductors sales office. In case of any inconsistency or conflict with the short data sheet, the full data sheet shall prevail.

Product specification — The information and data provided in a Product data sheet shall define the specification of the product as agreed between NXP Semiconductors and its customer, unless NXP Semiconductors and customer have explicitly agreed otherwise in writing. In no event however, shall an agreement be valid in which the NXP Semiconductors product is deemed to offer functions and qualities beyond those described in the Product data sheet.

15.3 Disclaimers

Limited warranty and liability — Information in this document is believed to be accurate and reliable. However, NXP Semiconductors does not give any representations or warranties, expressed or implied, as to the accuracy or completeness of such information and shall have no liability for the consequences of use of such information. NXP Semiconductors takes no responsibility for the content in this document if provided by an information source outside of NXP Semiconductors.

In no event shall NXP Semiconductors be liable for any indirect, incidental, punitive, special or consequential damages (including - without limitation - lost profits, lost savings, business interruption, costs related to the removal or replacement of any products or rework charges) whether or not such damages are based on tort (including negligence), warranty, breach of contract or any other legal theory.

Notwithstanding any damages that customer might incur for any reason whatsoever, NXP Semiconductors' aggregate and cumulative liability towards customer for the products described herein shall be limited in accordance with the *Terms and conditions of commercial sale* of NXP Semiconductors.

Right to make changes — NXP Semiconductors reserves the right to make changes to information published in this document, including without limitation specifications and product descriptions, at any time and without notice. This document supersedes and replaces all information supplied prior to the publication hereof.

Suitability for use in automotive applications — This NXP Semiconductors product has been qualified for use in automotive applications. Unless otherwise agreed in writing, the product is not designed, authorized or warranted to be suitable for use in life support, life-critical or safety-critical systems or equipment, nor in applications where failure or malfunction of an NXP Semiconductors product can reasonably be expected to result in personal injury, death or severe property or environmental damage. NXP Semiconductors and its suppliers accept no liability for inclusion and/or use of NXP Semiconductors products in such equipment or applications and therefore such inclusion and/or use is at the customer's own risk.

Applications — Applications that are described herein for any of these products are for illustrative purposes only. NXP Semiconductors makes no representation or warranty that such applications will be suitable for the specified use without further testing or modification.

Customers are responsible for the design and operation of their applications and products using NXP Semiconductors products, and NXP Semiconductors accepts no liability for any assistance with applications or customer product design. It is customer's sole responsibility to determine whether the NXP Semiconductors product is suitable and fit for the customer's applications and products planned, as well as for the planned application and use of customer's third party customer(s). Customers should provide appropriate design and operating safeguards to minimize the risks associated with their applications and products.

NXP Semiconductors does not accept any liability related to any default, damage, costs or problem which is based on any weakness or default in the customer's applications or products, or the application or use by customer's third party customer(s). Customer is responsible for doing all necessary testing for the customer's applications and products using NXP Semiconductors products in order to avoid a default of the applications and the products or of the application or use by customer's third party customer(s). NXP does not accept any liability in this respect.

Limiting values — Stress above one or more limiting values (as defined in the Absolute Maximum Ratings System of IEC 60134) will cause permanent damage to the device. Limiting values are stress ratings only and (proper) operation of the device at these or any other conditions above those given in the Recommended operating conditions section (if present) or the Characteristics sections of this document is not warranted. Constant or repeated exposure to limiting values will permanently and irreversibly affect the quality and reliability of the device.

Terms and conditions of commercial sale — NXP Semiconductors products are sold subject to the general terms and conditions of commercial sale, as published at <http://www.nxp.com/profile/terms>, unless otherwise agreed in a valid written individual agreement. In case an individual agreement is concluded only the terms and conditions of the respective agreement shall apply. NXP Semiconductors hereby expressly objects to applying the customer's general terms and conditions with regard to the purchase of NXP Semiconductors products by customer.

No offer to sell or license — Nothing in this document may be interpreted or construed as an offer to sell products that is open for acceptance or the grant, conveyance or implication of any license under any copyrights, patents or other industrial or intellectual property rights.

Export control — This document as well as the item(s) described herein may be subject to export control regulations. Export might require a prior authorization from competent authorities.

Translations — A non-English (translated) version of a document is for reference only. The English version shall prevail in case of any discrepancy between the translated and English versions.

15.4 Trademarks

Notice: All referenced brands, product names, service names and trademarks are the property of their respective owners.

16. Contact information

For more information, please visit: <http://www.nxp.com>

For sales office addresses, please send an email to: salesaddresses@nxp.com

17. Contents

1	General description	1
2	Features and benefits	1
3	Ordering information	2
4	Functional diagram	2
5	Pinning information	3
5.1	Pinning	3
5.2	Pin description	3
6	Functional description	4
6.1	Function table	4
7	Limiting values	4
8	Recommended operating conditions	4
9	Static characteristics	5
10	Dynamic characteristics	6
11	Waveforms	7
12	Package outline	9
13	Abbreviations	12
14	Revision history	12
15	Legal information	13
15.1	Data sheet status	13
15.2	Definitions	13
15.3	Disclaimers	13
15.4	Trademarks	14
16	Contact information	14
17	Contents	15

Please be aware that important notices concerning this document and the product(s) described herein, have been included in section 'Legal information'.

© NXP B.V. 2013.

All rights reserved.

For more information, please visit: <http://www.nxp.com>

For sales office addresses, please send an email to: salesaddresses@nxp.com

Date of release: 22 April 2013

Document identifier: 74LVT_LVTH244A_Q100