

# 74LVT244B; 74LVTH244B

3.3 V octal buffer/line driver; 3-state

Rev. 03 — 3 March 2006

Product data sheet

## 1. General description

The 74LVT244B; 74LVTH244B is a high-performance BiCMOS product designed for  $V_{CC}$  operation at 3.3 V.

This device is an octal buffer that is ideal for driving bus lines. The device features two output enable inputs ( $\overline{1OE}$  and  $\overline{2OE}$ ), each controlling four of the 3-state outputs.

## 2. Features

- Octal bus interface
- 3-state buffers
- Speed upgrade of 74LVT244A
- Output capability: +64 mA and -32 mA
- TTL input and output switching levels
- Input and output interface capability to systems at 5 V supply
- Bus hold data inputs eliminate need for external pull-up resistors to hold unused inputs
- Power-up 3-state
- Live insertion and extraction permitted
- No bus current loading when output is tied to 5 V bus
- Latch-up protection:
  - ◆ JESD78: exceeds 500 mA
- ESD protection:
  - ◆ HBM EIA/JESD22-A114-C exceeds 2000 V
  - ◆ MM EIA/JESD22-A115-A 200 V

## 3. Quick reference data

**Table 1. Quick reference data**

$GND = 0 V$ ;  $T_{amb} = 25\text{ }^{\circ}\text{C}$ .

Symbol	Parameter	Conditions	Min	Typ	Max	Unit
$t_{PLH}$	LOW-to-HIGH propagation delay $nAn$ to $nYn$	$C_L = 50\text{ pF}$ ; $V_{CC} = 3.3\text{ V}$	-	1.9	-	ns
$t_{PHL}$	HIGH-to-LOW propagation delay $nAn$ to $nYn$	$C_L = 50\text{ pF}$ ; $V_{CC} = 3.3\text{ V}$	-	2.0	-	ns

**PHILIPS**

Table 1. Quick reference data ...continued

 $GND = 0\text{ V}$ ;  $T_{amb} = 25\text{ }^{\circ}\text{C}$ .

Symbol	Parameter	Conditions	Min	Typ	Max	Unit
$C_i$	input capacitance	$V_I = 0\text{ V}$ or $3.0\text{ V}$	-	4	-	pF
$C_o$	output capacitance	outputs disabled; $V_O = 0\text{ V}$ or $3.0\text{ V}$	-	8	-	pF
$I_{CC}$	quiescent supply current	outputs disabled; $V_{CC} = 3.6\text{ V}$ ; $I_O = 0\text{ A}$ ; $V_I = GND$ or $V_{CC}$	-	0.13	-	mA

## 4. Ordering information

Table 2. Ordering information

Type number	Package			Version
	Temperature range	Name	Description	
74LVT244BD	-40 °C to +85 °C	SO20	plastic small outline package; 20 leads; body width 7.5 mm	SOT163-1
74LVT244BDB	-40 °C to +85 °C	SSOP20	plastic shrink small outline package; 20 leads; body width 5.3 mm	SOT339-1
74LVT244BPW	-40 °C to +85 °C	TSSOP20	plastic thin shrink small outline package; 20 leads; body width 4.4 mm	SOT360-1
74LVTH244BD	-40 °C to +85 °C	SO20	plastic small outline package; 20 leads; body width 7.5 mm	SOT163-1
74LVTH244BDB	-40 °C to +85 °C	SSOP20	plastic shrink small outline package; 20 leads; body width 5.3 mm	SOT339-1
74LVTH244BPW	-40 °C to +85 °C	TSSOP20	plastic thin shrink small outline package; 20 leads; body width 4.4 mm	SOT360-1

5. Functional diagram

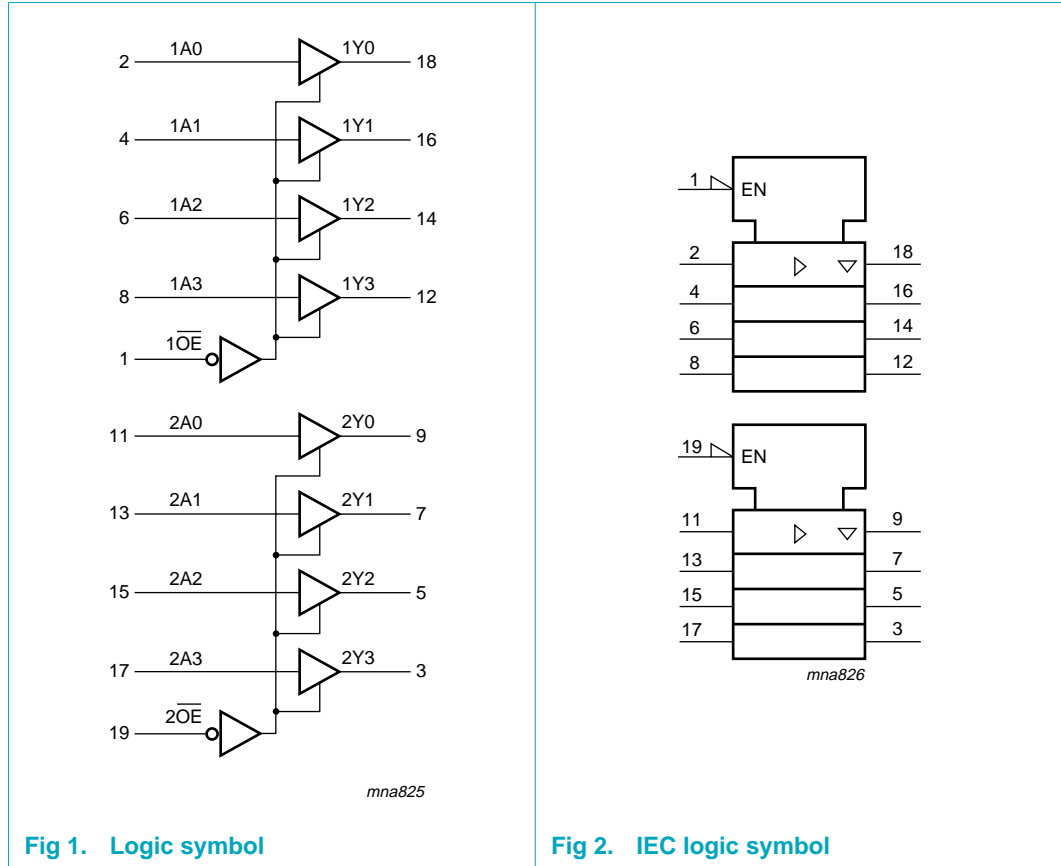

6. Pinning information

6.1 Pinning

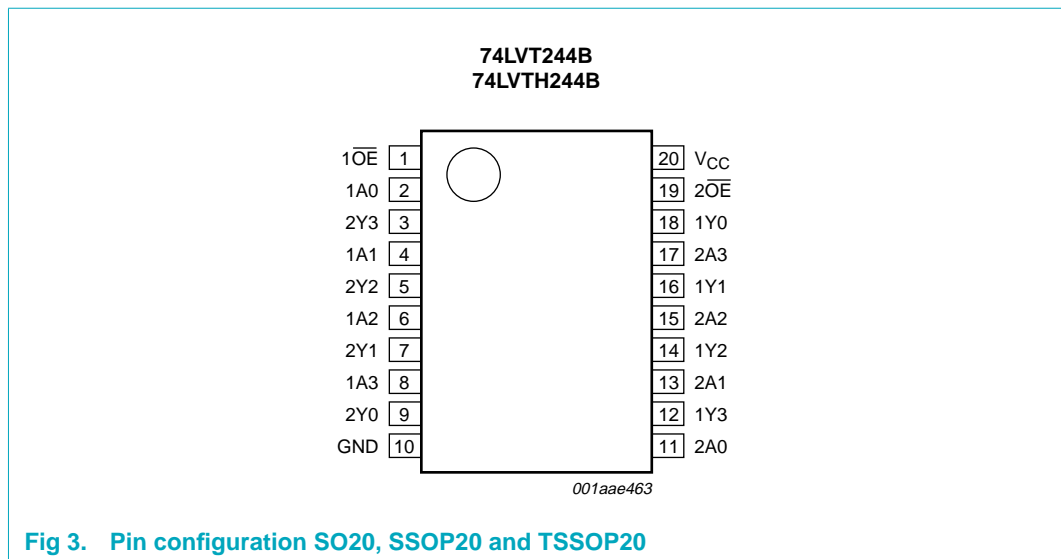

## 6.2 Pin description

Table 3. Pin description

Symbol	Pin	Description
$1\overline{OE}$	1	1 output enable input
1A0	2	1 data input 0
2Y3	3	2 data output 3
1A1	4	1 data input 1
2Y2	5	2 data output 2
1A2	6	1 data input 2
2Y1	7	2 data output 1
1A3	8	1 data input 3
2Y0	9	2 data output 0
GND	10	ground (0 V)
2A0	11	2 data input 0
1Y3	12	1 data output 3
2A1	13	2 data input 1
1Y2	14	1 data output 2
2A2	15	2 data input 2
1Y1	16	1 data output 1
2A3	17	2 data input 3
1Y0	18	1 data output 0
$2\overline{OE}$	19	2 output enable input
V <sub>CC</sub>	20	supply voltage

## 7. Functional description

### 7.1 Function table

Table 4. Function table [\[1\]](#)

Control	Input	Output
$n\overline{OE}$	nAn	nYn
L	L	L
	H	H
H	X	Z

- [1] H = HIGH voltage level;  
 L = LOW voltage level;  
 X = don't care;  
 Z = high-impedance OFF-state.

## 8. Limiting values

**Table 5. Limiting values**

In accordance with the Absolute Maximum Rating System (IEC 60134). Voltages are referenced to GND (ground = 0 V).

Symbol	Parameter	Conditions	Min	Max	Unit
$V_{CC}$	supply voltage		-0.5	+4.6	V
$V_I$	input voltage		[1] -0.5	+7.0	V
$V_O$	output voltage	output in OFF-state or HIGH-state	[1] -0.5	+7.0	V
$I_{IK}$	input clamping current	$V_I < 0$ V	-	-50	mA
$I_{OK}$	output clamping current	$V_O < 0$ V	-	-50	mA
$I_O$	output current	output in LOW-state	-	128	mA
		output in HIGH-state	-	-64	mA
$T_{stg}$	storage temperature		-65	+150	°C
$T_j$	junction temperature		[2] -	150	°C

[1] The input and output negative voltage ratings may be exceeded if the input and output clamp current ratings are observed.

[2] The performance capability of a high-performance integrated circuit in conjunction with its thermal environment can create junction temperatures which are detrimental to reliability.

## 9. Recommended operating conditions

**Table 6. Recommended operating conditions**

Symbol	Parameter	Conditions	Min	Typ	Max	Unit
$V_{CC}$	supply voltage		2.7	-	3.6	V
$V_I$	input voltage		0	-	5.5	V
$V_{IH}$	HIGH-state input voltage		2.0	-	-	V
$V_{IL}$	LOW-state input voltage		-	-	0.8	V
$I_{OH}$	HIGH-state output current		-	-	-32	mA
$I_{OL}$	LOW-state output current	none	-	-	32	mA
		current duty cycle $\leq 50$ %; $f_i \geq 1$ kHz	-	-	64	mA
$T_{amb}$	ambient temperature	in free-air	-40	-	+85	°C
$\Delta t/\Delta V$	input transition rise and fall rate	outputs enabled	-	-	10	ns/V

## 10. Static characteristics

**Table 7. Static characteristics**

At recommended operating conditions; voltages are referenced to GND (ground = 0 V).

Symbol	Parameter	Conditions	Min	Typ	Max	Unit	
<b><math>T_{amb} = -40\text{ °C to }+85\text{ °C}</math> [1]</b>							
$V_{IK}$	input clamping voltage	$V_{CC} = 2.7\text{ V}; I_{IK} = -18\text{ mA}$	-	-0.9	-1.2	V	
$V_{OH}$	HIGH-state output voltage	$V_{CC} = 2.7\text{ V}$					
		$I_{OH} = -100\text{ }\mu\text{A}$	$V_{CC} - 2.0$	$V_{CC} - 2.1$	-	V	
		$I_{OH} = -8\text{ mA}$	2.4	2.5	-	V	
		$V_{CC} = 3.0\text{ V}$					
$V_{OL}$	LOW-state output voltage	$V_{CC} = 2.7\text{ V}$					
		$I_{OL} = 100\text{ }\mu\text{A}$	-	0.1	0.2	V	
		$I_{OL} = 24\text{ mA}$	-	0.3	0.5	V	
		$V_{CC} = 3.0\text{ V}$					
$V_{OL}$	LOW-state output voltage	$V_{CC} = 3.0\text{ V}$					
		$I_{OL} = 16\text{ mA}$	-	0.25	0.4	V	
		$I_{OL} = 32\text{ mA}$	-	0.3	0.5	V	
		$I_{OL} = 64\text{ mA}$	-	0.4	0.55	V	
$I_{LI}$	input leakage current	all pins	$V_{CC} = 0\text{ V or }3.6\text{ V}; V_I = 5.5\text{ V}$	-	0.1	10	$\mu\text{A}$
		control pins	$V_{CC} = 3.6\text{ V}; V_I = V_{CC}\text{ or GND}$	-	$\pm 0.1$	$\pm 1$	$\mu\text{A}$
		I/O data pins	$V_{CC} = 3.6\text{ V}$	[2]			
			$V_I = V_{CC}$	-	0.1	1	$\mu\text{A}$
$I_{OFF}$	power-off leakage current	$V_{CC} = 0\text{ V}; V_I\text{ or }V_O = 0\text{ V to }4.5\text{ V}$	-	1	$\pm 100$	$\mu\text{A}$	
		$V_I = 0\text{ V}$	-	-1	-5	$\mu\text{A}$	
$I_{HOLD}$	bus hold current data input	$V_{CC} = 3\text{ V}$	[3]				
		$V_I = 0.8\text{ V}$	75	130	-	$\mu\text{A}$	
		$V_I = 2.0\text{ V}$	-75	-140	-	$\mu\text{A}$	
		$V_{CC} = 0\text{ V to }3.6\text{ V}$					
$I_{EX}$	external current into output	$V_I = 3.6\text{ V}$	$\pm 500$	-	-	$\mu\text{A}$	
		output in HIGH-state when $V_O > V_{CC}; V_O = 5.5\text{ V}; V_{CC} = 3.3\text{ V}$	-	60	125	$\mu\text{A}$	
$I_{O(pu/pd)}$	power-up/power-down output current	$V_{CC} \leq 1.2\text{ V}; V_O = 0.5\text{ V to }V_{CC}; V_I = \text{GND or }V_{CC}; \overline{nOE} = \text{don't care}$	[4]	$\pm 1$	$\pm 100$	$\mu\text{A}$	
$I_{OZ}$	OFF-state output current	$V_{CC} = 3.6\text{ V}; V_I = V_{IH}\text{ or }V_{IL}$					
		output HIGH: $V_O = 3.0\text{ V}$	-	1	5	$\mu\text{A}$	
		output LOW: $V_O = 0.5\text{ V}$	-	-1	-5	$\mu\text{A}$	
$I_{CC}$	quiescent supply current	$V_{CC} = 3.6\text{ V}; V_I = \text{GND or }V_{CC}; I_O = 0\text{ A}$					
		output HIGH	-	0.13	0.19	mA	
		output LOW	-	2	5	mA	
		outputs disabled	[5]	-	0.13	0.19	mA

**Table 7.** Static characteristics ...continued

At recommended operating conditions; voltages are referenced to GND (ground = 0 V).

Symbol	Parameter	Conditions	Min	Typ	Max	Unit
$\Delta I_{CC}$	additional quiescent supply current	per input pin; $V_{CC} = 3.0$ V to 3.6 V; one input at $V_{CC} - 0.6$ V and other inputs at $V_{CC}$ or GND	[6] -	0.1	0.2	mA
$C_i$	input capacitance	$V_I = 0$ V or 3.0 V	-	4	-	pF
$C_o$	output capacitance	outputs disabled; $V_O = 0$ V or 3.0 V	-	8	-	pF

[1] Typical values are measured at  $T_{amb} = 25$  °C.[2] Unused pins at  $V_{CC}$  or GND.

[3] This is the bus hold overdrive current required to force the input to the opposite logic state.

[4] This parameter is valid for any  $V_{CC}$  between 0 V and 1.2 V with a transition time of up to 10 ms. From  $V_{CC} = 1.2$  V to  $V_{CC} = 3.3$  V  $\pm$  0.3 V a transition time of 100  $\mu$ s is permitted. This parameter is valid for  $T_{amb} = 25$  °C only.[5]  $I_{CC}$  is measured with outputs pulled to  $V_{CC}$  or GND.[6] This is the increase in supply current for each input at  $V_{CC} - 0.6$  V.

## 11. Dynamic characteristics

**Table 8.** Dynamic characteristicsVoltages are referenced to GND (ground = 0 V); for test circuit see [Figure 6](#).

Symbol	Parameter	Conditions	Min	Typ	Max	Unit
<b><math>T_{amb} = -40</math> °C to <math>+85</math> °C [1]</b>						
$t_{PLH}$	LOW-to-HIGH propagation delay nAn to nYn	see <a href="#">Figure 4</a>	-	-	3.8	ns
		$V_{CC} = 2.7$ V	-	-	3.8	ns
		$V_{CC} = 3.0$ V to 3.6 V	1.1	1.9	3.5	ns
$t_{PHL}$	HIGH-to-LOW propagation delay nAn to nYn	see <a href="#">Figure 4</a>	-	-	3.6	ns
		$V_{CC} = 2.7$ V	-	-	3.6	ns
		$V_{CC} = 3.0$ V to 3.6 V	1.3	2.0	3.3	ns
$t_{PZH}$	output enable time to HIGH-level $\overline{nOE}$ to nYn	see <a href="#">Figure 5</a>	-	-	5.3	ns
		$V_{CC} = 2.7$ V	-	-	5.3	ns
		$V_{CC} = 3.0$ V to 3.6 V	1.1	2.8	4.5	ns
$t_{PZL}$	output enable time to LOW-level $\overline{nOE}$ to nYn	see <a href="#">Figure 5</a>	-	-	4.9	ns
		$V_{CC} = 2.7$ V	-	-	4.9	ns
		$V_{CC} = 3.0$ V to 3.6 V	1.4	2.3	4.4	ns
$t_{PHZ}$	output disable time from HIGH-level $\overline{nOE}$ to nYn	see <a href="#">Figure 5</a>	-	-	4.5	ns
		$V_{CC} = 2.7$ V	-	-	4.5	ns
		$V_{CC} = 3.0$ V to 3.6 V	1.9	2.9	4.4	ns
$t_{PLZ}$	output disable time from LOW-level $\overline{nOE}$ to nYn	see <a href="#">Figure 5</a>	-	-	4.4	ns
		$V_{CC} = 2.7$ V	-	-	4.4	ns
		$V_{CC} = 3.0$ V to 3.6 V	1.8	2.5	4.4	ns

[1] Typical values are measured at  $V_{CC} = 3.3$  V and  $T_{amb} = 25$  °C.

12. Waveforms

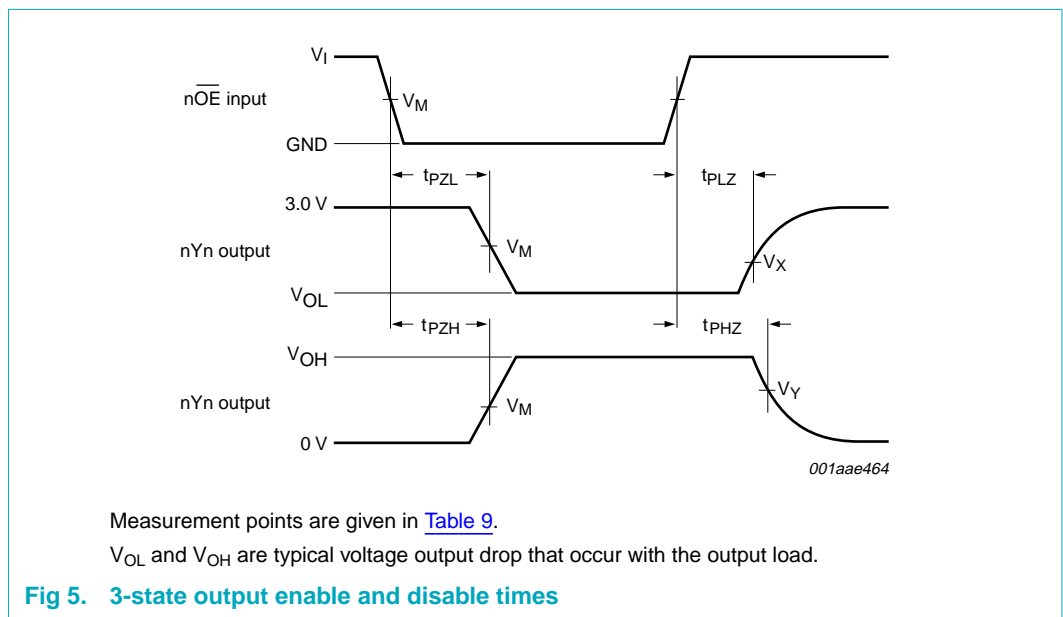
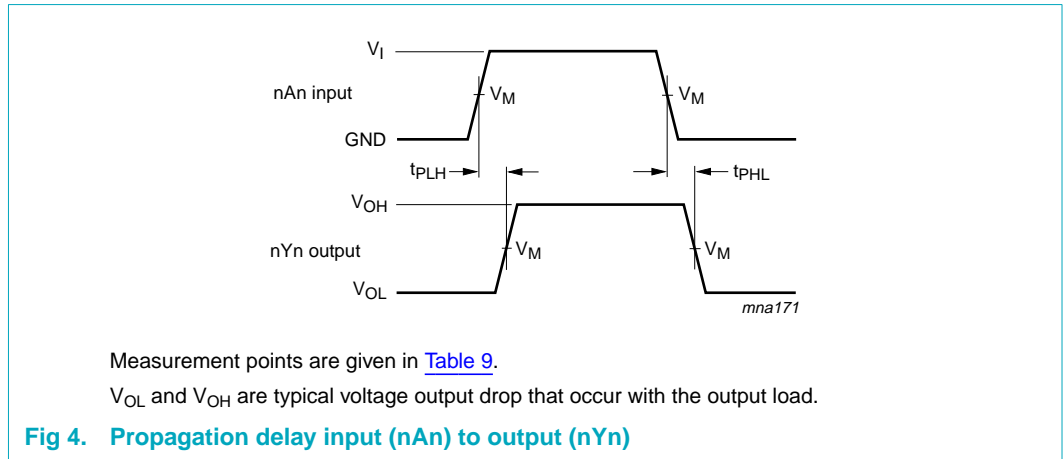

**Table 9. Measurement points**

Input	Output		
$V_M$	$V_M$	$V_X$	$V_Y$
1.5 V	1.5 V	$V_{OL} + 0.3 V$	$V_{OH} - 0.3 V$

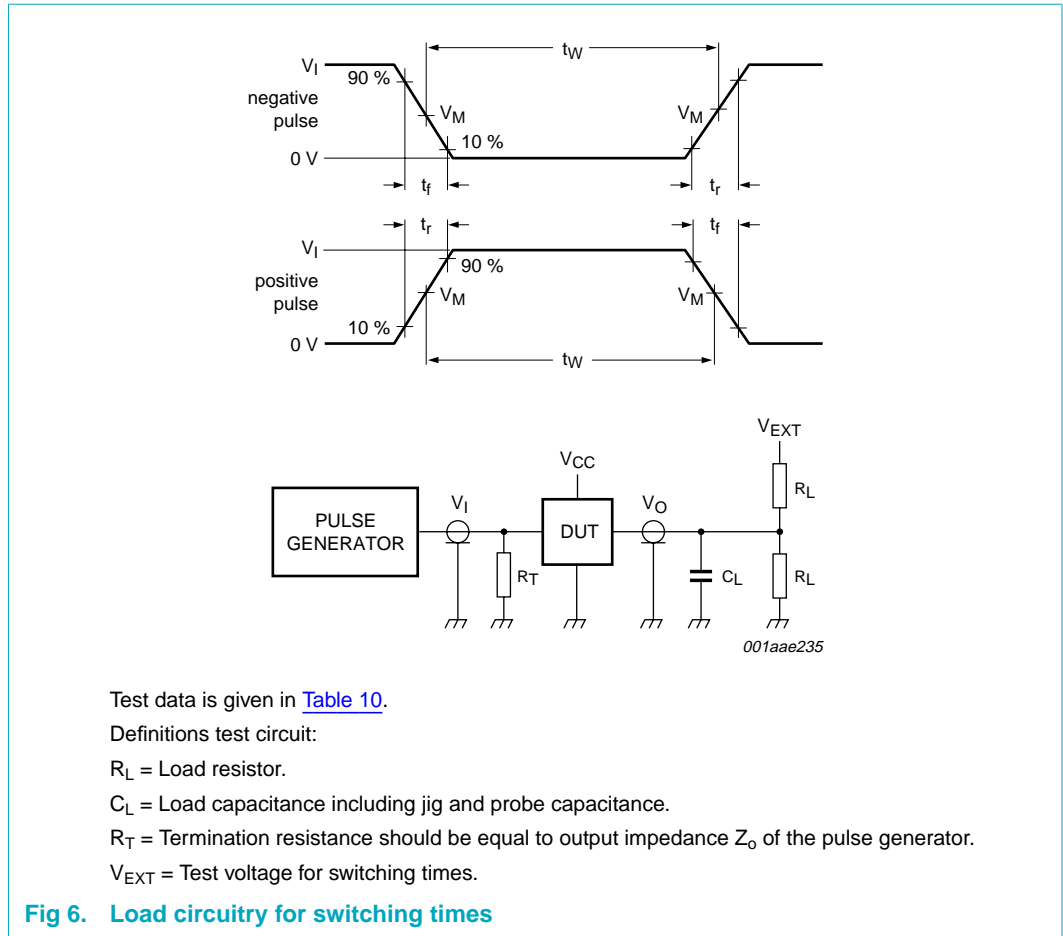

**Table 10. Test data**

Input				Load		$V_{EXT}$		
$V_I$	$f_i$	$t_w$	$t_r, t_f$	$C_L$	$R_L$	$t_{PHZ}, t_{PZH}$	$t_{PLZ}, t_{PZL}$	$t_{PLH}, t_{PHL}$
2.7 V	$\leq 10$ MHz	500 ns	$\leq 2.5$ ns	50 pF	500 $\Omega$	GND	6 V	open

13. Package outline

SO20: plastic small outline package; 20 leads; body width 7.5 mm

SOT163-1

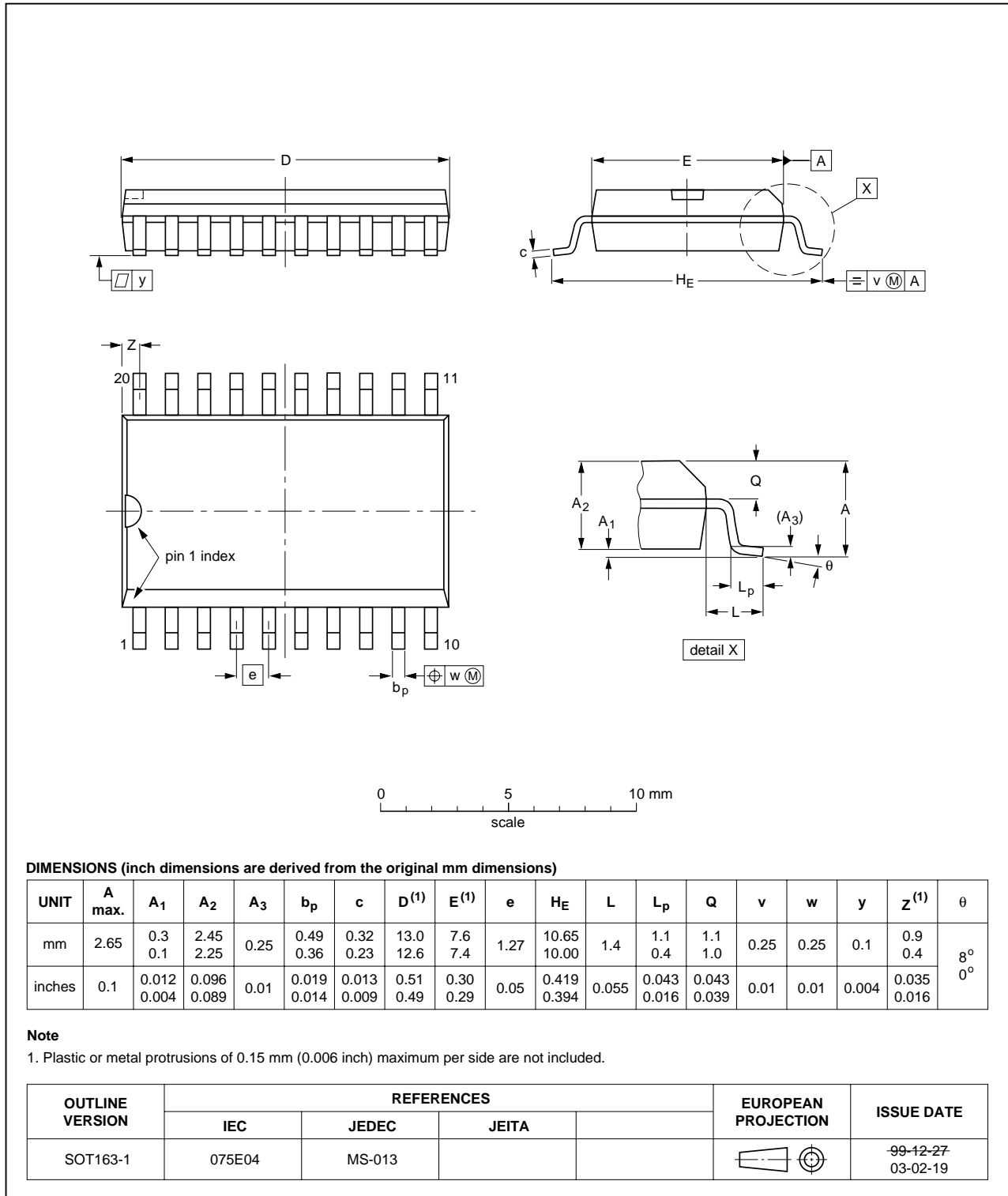

Fig 7. Package outline SOT163-1 (SO20)

SSOP20: plastic shrink small outline package; 20 leads; body width 5.3 mm

SOT339-1

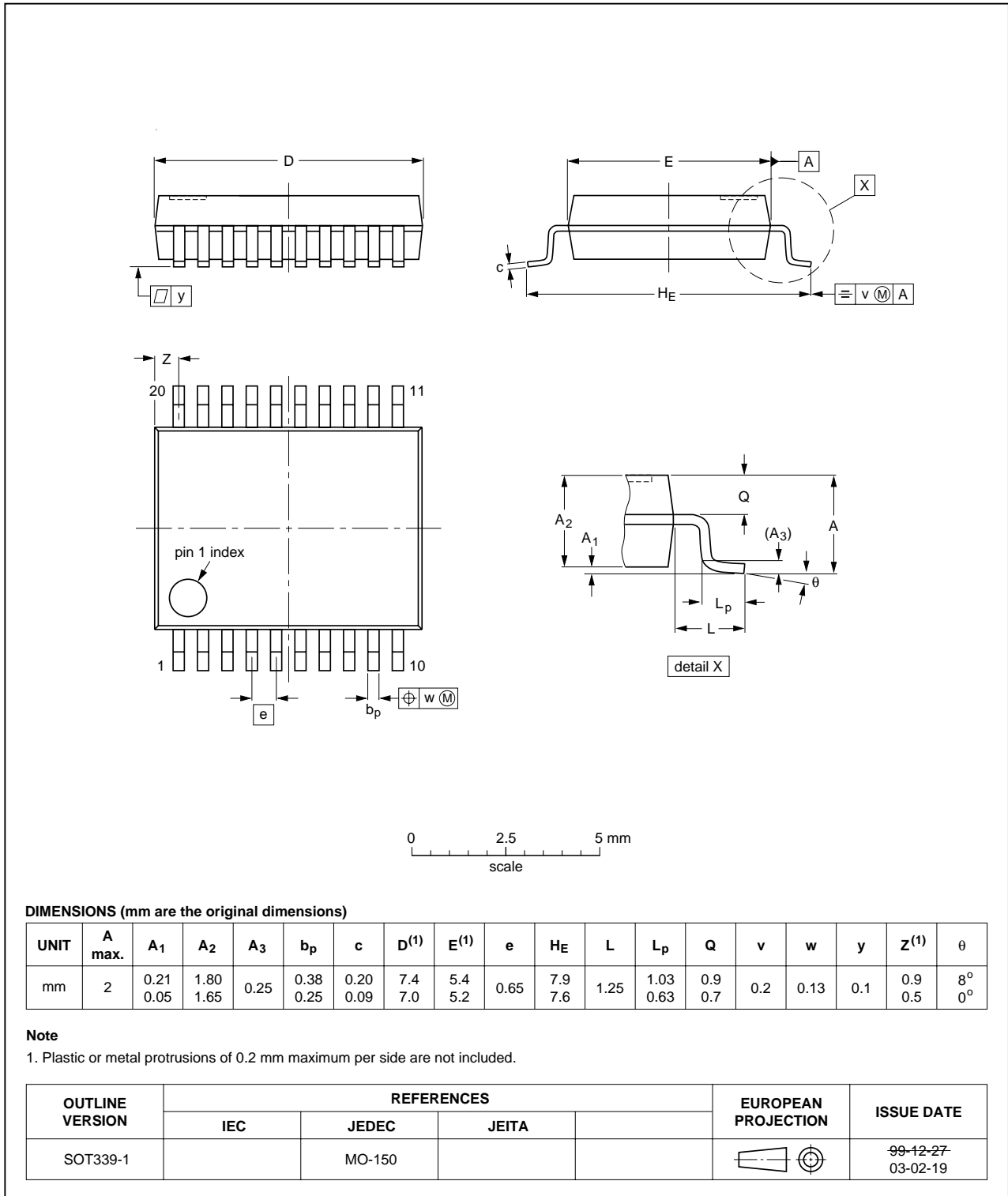

Fig 8. Package outline SOT339-1 (SSOP20)

TSSOP20: plastic thin shrink small outline package; 20 leads; body width 4.4 mm

SOT360-1

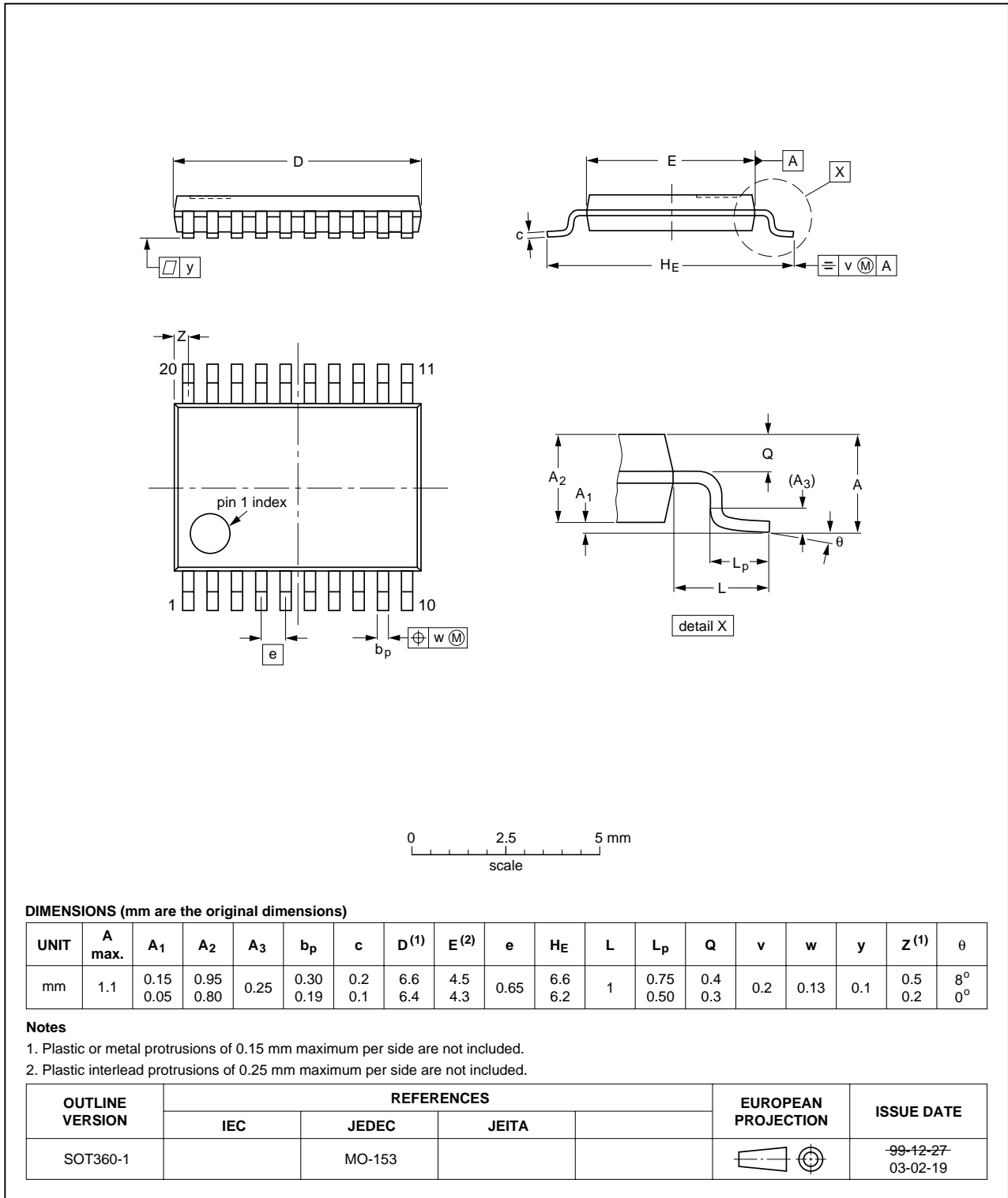

Fig 9. Package outline SOT360-1 (TSSOP20)

## 14. Abbreviations

Table 11. Abbreviations

Acronym	Description
BiCMOS	Bipolar Complementary Metal Oxide Semiconductor
DUT	Device Under Test
ESD	ElectroStatic Discharge
HBM	Human Body Model
MM	Machine Model
TTL	Transistor-Transistor Logic

## 15. Revision history

Table 12. Revision history

Document ID	Release date	Data sheet status	Change notice	Supersedes
74LVT_LVTH244B_3	20060303	Product data sheet	-	74LVT244B_2 (9397 750 11918)
Modifications:	<ul style="list-style-type: none"> <li>The format of this data sheet has been redesigned to comply with the new presentation and information standard of Philips Semiconductors.</li> <li><a href="#">Section 4</a>: Added type numbers 74LVTH244BD, 74LVTH244BDB and 74LVTH244BPW.</li> </ul>			
74LVT244B_2	20030919	Product specification	-	74LVT244B_1 (9397 750 04814)
74LVT244B_1	19981101	Product specification	-	-

## 16. Legal information

### 16.1 Data sheet status

Document status <sup>[1][2]</sup>	Product status <sup>[3]</sup>	Definition
Objective [short] data sheet	Development	This document contains data from the objective specification for product development.
Preliminary [short] data sheet	Qualification	This document contains data from the preliminary specification.
Product [short] data sheet	Production	This document contains the product specification.

[1] Please consult the most recently issued document before initiating or completing a design.

[2] The term 'short data sheet' is explained in section "Definitions".

[3] The product status of device(s) described in this document may have changed since this document was published and may differ in case of multiple devices. The latest product status information is available on the Internet at URL <http://www.semiconductors.philips.com>.

### 16.2 Definitions

**Draft** — The document is a draft version only. The content is still under internal review and subject to formal approval, which may result in modifications or additions. Philips Semiconductors does not give any representations or warranties as to the accuracy or completeness of information included herein and shall have no liability for the consequences of use of such information.

**Short data sheet** — A short data sheet is an extract from a full data sheet with the same product type number(s) and title. A short data sheet is intended for quick reference only and should not be relied upon to contain detailed and full information. For detailed and full information see the relevant full data sheet, which is available on request via the local Philips Semiconductors sales office. In case of any inconsistency or conflict with the short data sheet, the full data sheet shall prevail.

### 16.3 Disclaimers

**General** — Information in this document is believed to be accurate and reliable. However, Philips Semiconductors does not give any representations or warranties, expressed or implied, as to the accuracy or completeness of such information and shall have no liability for the consequences of use of such information.

**Right to make changes** — Philips Semiconductors reserves the right to make changes to information published in this document, including without limitation specifications and product descriptions, at any time and without notice. This document supersedes and replaces all information supplied prior to the publication hereof.

**Suitability for use** — Philips Semiconductors products are not designed, authorized or warranted to be suitable for use in medical, military, aircraft, space or life support equipment, nor in applications where failure or

malfunction of a Philips Semiconductors product can reasonably be expected to result in personal injury, death or severe property or environmental damage. Philips Semiconductors accepts no liability for inclusion and/or use of Philips Semiconductors products in such equipment or applications and therefore such inclusion and/or use is for the customer's own risk.

**Applications** — Applications that are described herein for any of these products are for illustrative purposes only. Philips Semiconductors makes no representation or warranty that such applications will be suitable for the specified use without further testing or modification.

**Limiting values** — Stress above one or more limiting values (as defined in the Absolute Maximum Ratings System of IEC 60134) may cause permanent damage to the device. Limiting values are stress ratings only and operation of the device at these or any other conditions above those given in the Characteristics sections of this document is not implied. Exposure to limiting values for extended periods may affect device reliability.

**Terms and conditions of sale** — Philips Semiconductors products are sold subject to the general terms and conditions of commercial sale, as published at <http://www.semiconductors.philips.com/profile/terms>, including those pertaining to warranty, intellectual property rights infringement and limitation of liability, unless explicitly otherwise agreed to in writing by Philips Semiconductors. In case of any inconsistency or conflict between information in this document and such terms and conditions, the latter will prevail.

**No offer to sell or license** — Nothing in this document may be interpreted or construed as an offer to sell products that is open for acceptance or the grant, conveyance or implication of any license under any copyrights, patents or other industrial or intellectual property rights.

### 16.4 Trademarks

Notice: All referenced brands, product names, service names and trademarks are the property of their respective owners.

## 17. Contact information

For additional information, please visit: <http://www.semiconductors.philips.com>

For sales office addresses, send an email to: [sales.addresses@www.semiconductors.philips.com](mailto:sales.addresses@www.semiconductors.philips.com)

## 18. Contents

<b>1</b>	<b>General description</b> .....	<b>1</b>
<b>2</b>	<b>Features</b> .....	<b>1</b>
<b>3</b>	<b>Quick reference data</b> .....	<b>1</b>
<b>4</b>	<b>Ordering information</b> .....	<b>2</b>
<b>5</b>	<b>Functional diagram</b> .....	<b>3</b>
<b>6</b>	<b>Pinning information</b> .....	<b>3</b>
6.1	Pinning .....	3
6.2	Pin description .....	4
<b>7</b>	<b>Functional description</b> .....	<b>4</b>
7.1	Function table .....	4
<b>8</b>	<b>Limiting values</b> .....	<b>5</b>
<b>9</b>	<b>Recommended operating conditions</b> .....	<b>5</b>
<b>10</b>	<b>Static characteristics</b> .....	<b>6</b>
<b>11</b>	<b>Dynamic characteristics</b> .....	<b>7</b>
<b>12</b>	<b>Waveforms</b> .....	<b>8</b>
<b>13</b>	<b>Package outline</b> .....	<b>10</b>
<b>14</b>	<b>Abbreviations</b> .....	<b>13</b>
<b>15</b>	<b>Revision history</b> .....	<b>13</b>
<b>16</b>	<b>Legal information</b> .....	<b>14</b>
16.1	Data sheet status .....	14
16.2	Definitions .....	14
16.3	Disclaimers .....	14
16.4	Trademarks .....	14
<b>17</b>	<b>Contact information</b> .....	<b>14</b>
<b>18</b>	<b>Contents</b> .....	<b>15</b>



Please be aware that important notices concerning this document and the product(s) described herein, have been included in section 'Legal information'.

© Koninklijke Philips Electronics N.V. 2006. All rights reserved.

For more information, please visit: <http://www.semiconductors.philips.com>.

For sales office addresses, email to: [sales.addresses@www.semiconductors.philips.com](mailto:sales.addresses@www.semiconductors.philips.com).

Date of release: 3 March 2006

Document identifier: 74LVT\_LVTH244B\_3