

# BAS21H

Single high-voltage switching diode

Rev. 02 — 3 November

Product data sheet

## 1. Product profile

### 1.1 General description

Single high-voltage switching diode, encapsulated in a SOD123F small and flat lead Surface-Mounted Device (SMD) plastic package.

### 1.2 Features

- Small and flat lead SMD plastic package
- Reverse voltage:  $V_R \leq 200$  V

### 1.3 Applications

- General-purpose switching

### 1.4 Quick reference data

Table 1. Quick reference data



Symbol	Parameter	Conditions	Min	Typ	Max	Unit
$I_F$	forward current	[1]	-	-	200	mA
$V_R$	reverse voltage		-	-	200	V
$t_{rr}$	reverse recovery time	[2]	-	-	50	ns

[1] Pulse test:  $t_p \leq 300$   $\mu$ s;  $\delta \leq 0.02$ .

[2] When switched from  $I_F = 30$  mA to  $I_R = 30$  mA;  $R_L = 100$   $\Omega$ ; measured at  $I_R = 3$  mA.

## 2. Pinning information

Table 2. Pinning

Pin	Description	Simplified outline	Symbol
1	cathode	[1]	1  2
2	anode		<i>sym001</i>

[1] The marking bar indicates the cathode.

## 3. Ordering information

Table 3. Ordering information

Type number	Package		
	Name	Description	Version
BAS21H	-	plastic surface-mounted package; 2 leads	SOD123F

## 4. Marking

Table 4. Marking codes

Type number	Marking code
BAS21H	B2

## 5. Limiting values

**Table 5. Limiting values**

In accordance with the Absolute Maximum Rating System (IEC 60134).

Symbol	Parameter	Conditions	Min	Max	Unit
$V_{RRM}$	repetitive peak reverse voltage		-	250	V
$V_R$	reverse voltage		-	200	V
$I_F$	forward current		[1]	200	mA
$I_{FRM}$	repetitive peak forward current	$t_p = 1$ ms; $\delta = 0.25$	-	625	mA
$I_{FSM}$	non-repetitive peak forward current	square wave	[2]		
		$t_p = 1$ $\mu$ s	-	9	A
		$t_p = 100$ $\mu$ s	-	3	A
		$t_p = 10$ ms	-	1.7	A
$P_{tot}$	total power dissipation	$T_{amb} \leq 25$ °C	[3]	375	mW
$T_j$	junction temperature		-	150	°C
$T_{amb}$	ambient temperature		-65	+150	°C
$T_{stg}$	storage temperature		-65	+150	°C

[1] Pulse test:  $t_p \leq 300$   $\mu$ s;  $\delta \leq 0.02$ .

[2]  $T_j = 25$  °C prior to surge.

[3] Device mounted on an FR4 Printed-Circuit Board (PCB), single-sided copper, tin-plated and standard footprint.

## 6. Thermal characteristics

**Table 6. Thermal characteristics**

Symbol	Parameter	Conditions	Min	Typ	Max	Unit
$R_{th(j-a)}$	thermal resistance from junction to ambient	in free air	[1][2]	-	330	K/W
$R_{th(j-sp)}$	thermal resistance from junction to solder point		[3]	-	70	K/W

[1] Device mounted on an FR4 PCB, single-sided copper, tin-plated and standard footprint.

[2] Reflow soldering is the only recommended soldering method.

[3] Soldering point of cathode tab.

## 7. Characteristics

**Table 7. Characteristics**

$T_{amb} = 25\text{ }^{\circ}\text{C}$  unless otherwise specified.

Symbol	Parameter	Conditions	Min	Typ	Max	Unit
$V_F$	forward voltage	$I_F = 100\text{ mA}$	[1]	-	1	V
		$I_F = 200\text{ mA}$	[1]	-	1.25	V
$I_R$	reverse current	$V_R = 200\text{ V}$	-	-	100	nA
		$V_R = 200\text{ V}; T_j = 150\text{ }^{\circ}\text{C}$	-	-	100	$\mu\text{A}$
$C_d$	diode capacitance	$V_R = 0\text{ V}; f = 1\text{ MHz}$	-	-	5	pF
$t_{rr}$	reverse recovery time		[2]	-	50	ns

[1] Pulse test:  $t_p \leq 300\text{ }\mu\text{s}$ ;  $\delta \leq 0.02$ .

[2] When switched from  $I_F = 30\text{ mA}$  to  $I_R = 30\text{ mA}$ ;  $R_L = 100\text{ }\Omega$ ; measured at  $I_R = 3\text{ mA}$ .

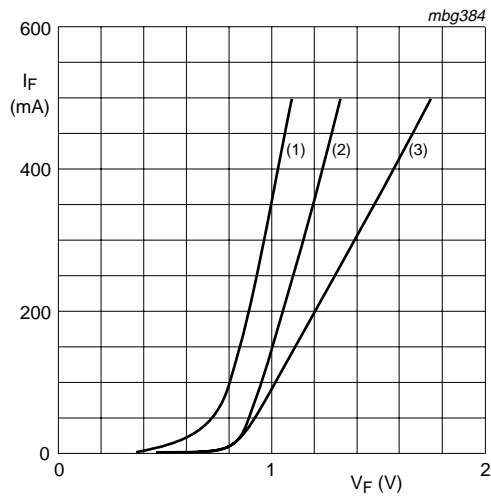

- (1)  $T_{amb} = 150\text{ °C}$ ; typical values
- (2)  $T_{amb} = 25\text{ °C}$ ; typical values
- (3)  $T_{amb} = 25\text{ °C}$ ; maximum values

**Fig 1. Forward current as a function of forward voltage**

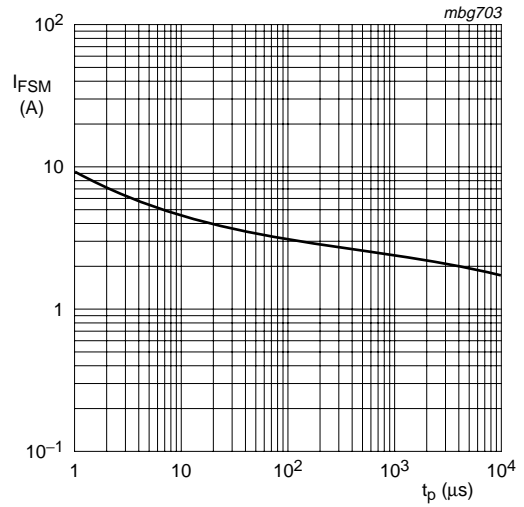

Based on square wave currents.  
 $T_j = 25\text{ °C}$ ; prior to surge

**Fig 2. Non-repetitive peak forward current as a function of pulse duration; maximum values**

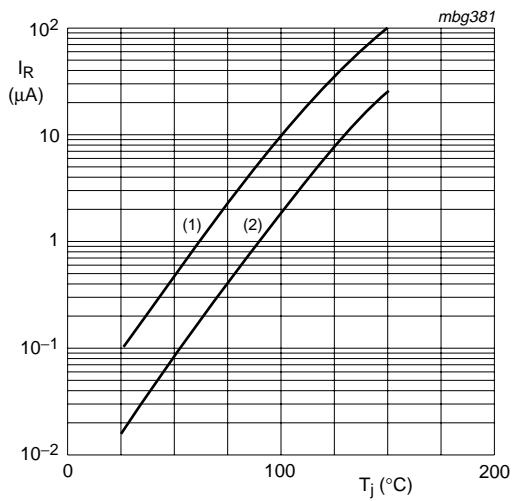

- (1)  $V_R = V_{Rmax}$ ; maximum values
- (2)  $V_R = V_{Rmax}$ ; typical values

**Fig 3. Reverse current as a function of junction temperature**

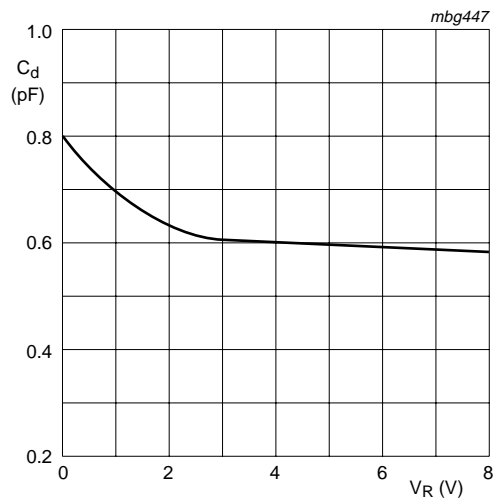

$f = 1\text{ MHz}$ ;  $T_{amb} = 25\text{ °C}$

**Fig 4. Diode capacitance as a function of reverse voltage; typical values**

### 8. Test information

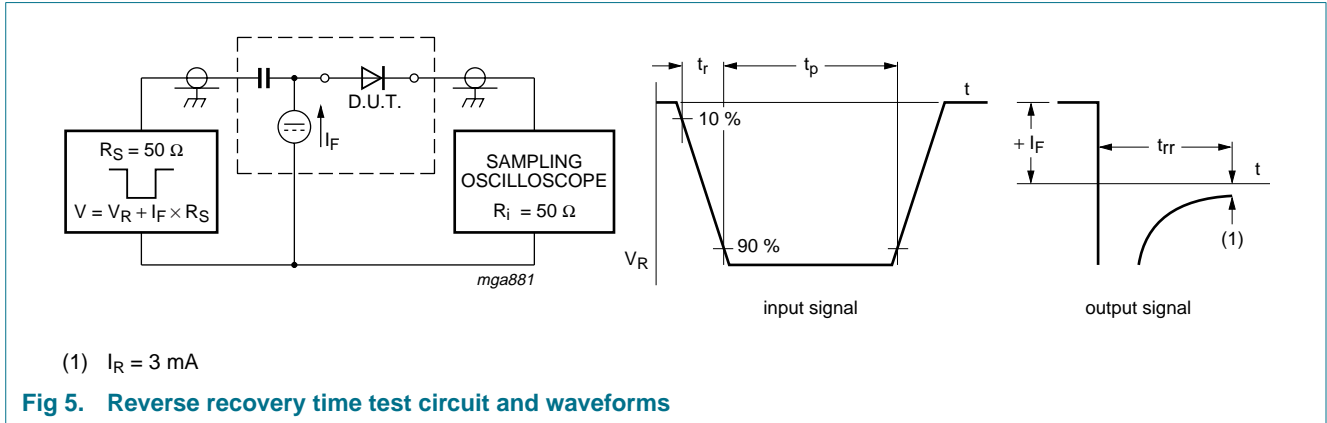

### 9. Package outline

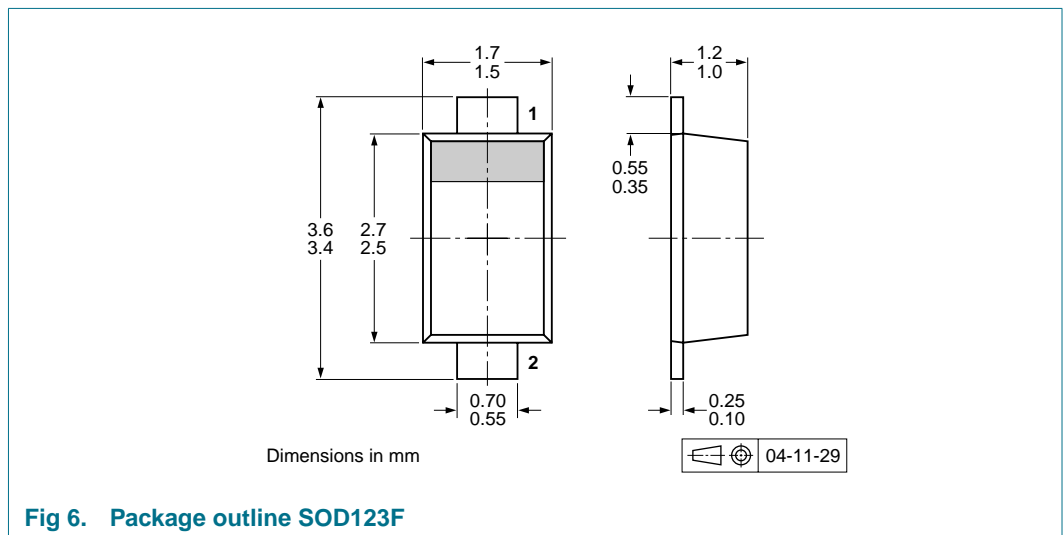

### 10. Packing information

**Table 8. Packing methods**

The indicated -xxx are the last three digits of the 12NC ordering code.<sup>[1]</sup>

Type number	Package	Description	Packing quantity	
			3000	10000
BAS21H	SOD123F	4 mm pitch, 8 mm tape and reel	-115	-135

[1] For further information and the availability of packing methods, see [Section 15](#).

## 11. Soldering

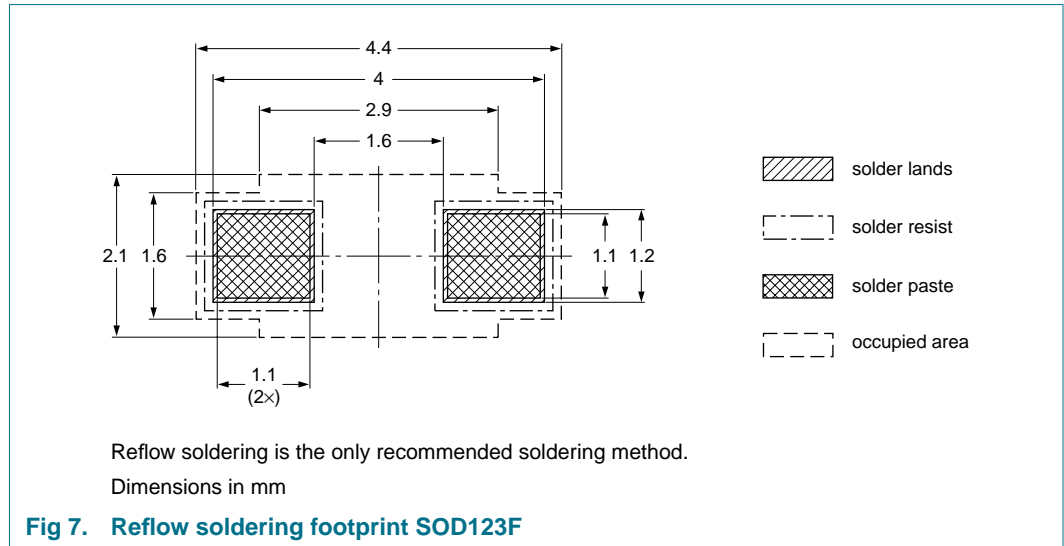

## 12. Mounting

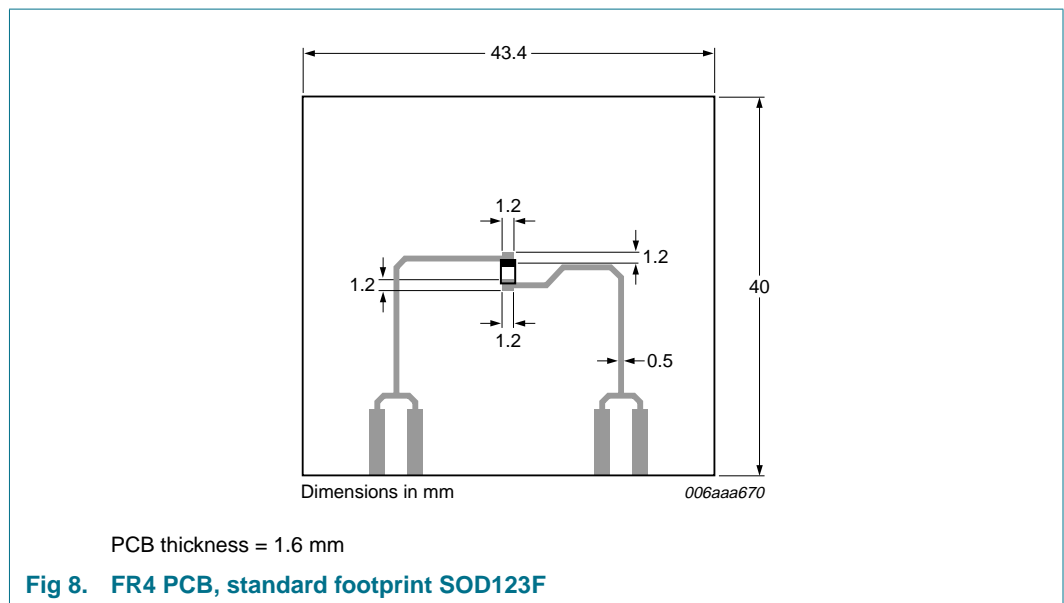

## 13. Revision history

**Table 9. Revision history**

Document ID	Release date	Data sheet status	Change notice	Supersedes
BAS21H_2	20061103	Product data sheet	-	BAS21H_1
Modifications:	<ul style="list-style-type: none"> <li>• The format of this data sheet has been redesigned to comply with the new identity guidelines of NXP Semiconductors.</li> <li>• Legal texts have been adapted to the new company name where appropriate.</li> <li>• <a href="#">Section 1.1 “General description”</a>: amended</li> <li>• <a href="#">Table 1 “Quick reference data”</a>: I<sub>F</sub> forward current table note added</li> <li>• <a href="#">Table 5 “Limiting values”</a>: I<sub>F</sub> forward current table note added</li> <li>• <a href="#">Table 5 “Limiting values”</a>: I<sub>FRM</sub> repetitive peak forward current condition amended</li> <li>• <a href="#">Table 5 “Limiting values”</a>: I<sub>FSM</sub> non-repetitive peak forward current condition amended</li> <li>• <a href="#">Table 6</a>: R<sub>th(j-sp)</sub> thermal resistance from junction to solder point table note added</li> <li>• <a href="#">Table 7 “Characteristics”</a>: V<sub>F</sub> forward voltage unit amended</li> <li>• <a href="#">Figure 2</a>: figure title and figure note amended</li> <li>• <a href="#">Figure 3</a>: amended</li> <li>• <a href="#">Section 12 “Mounting”</a>: added</li> <li>• <a href="#">Section 14.4 “Trademarks”</a>: added</li> </ul>			
BAS21H_1	20050411	Product data sheet	-	-

## 14. Legal information

### 14.1 Data sheet status

Document status <sup>[1][2]</sup>	Product status <sup>[3]</sup>	Definition
Objective [short] data sheet	Development	This document contains data from the objective specification for product development.
Preliminary [short] data sheet	Qualification	This document contains data from the preliminary specification.
Product [short] data sheet	Production	This document contains the product specification.

[1] Please consult the most recently issued document before initiating or completing a design.

[2] The term 'short data sheet' is explained in section "Definitions".

[3] The product status of device(s) described in this document may have changed since this document was published and may differ in case of multiple devices. The latest product status information is available on the Internet at URL <http://www.nxp.com>.

### 14.2 Definitions

**Draft** — The document is a draft version only. The content is still under internal review and subject to formal approval, which may result in modifications or additions. NXP Semiconductors does not give any representations or warranties as to the accuracy or completeness of information included herein and shall have no liability for the consequences of use of such information.

**Short data sheet** — A short data sheet is an extract from a full data sheet with the same product type number(s) and title. A short data sheet is intended for quick reference only and should not be relied upon to contain detailed and full information. For detailed and full information see the relevant full data sheet, which is available on request via the local NXP Semiconductors sales office. In case of any inconsistency or conflict with the short data sheet, the full data sheet shall prevail.

### 14.3 Disclaimers

**General** — Information in this document is believed to be accurate and reliable. However, NXP Semiconductors does not give any representations or warranties, expressed or implied, as to the accuracy or completeness of such information and shall have no liability for the consequences of use of such information.

**Right to make changes** — NXP Semiconductors reserves the right to make changes to information published in this document, including without limitation specifications and product descriptions, at any time and without notice. This document supersedes and replaces all information supplied prior to the publication hereof.

**Suitability for use** — NXP Semiconductors products are not designed, authorized or warranted to be suitable for use in medical, military, aircraft, space or life support equipment, nor in applications where failure or

malfunction of a NXP Semiconductors product can reasonably be expected to result in personal injury, death or severe property or environmental damage. NXP Semiconductors accepts no liability for inclusion and/or use of NXP Semiconductors products in such equipment or applications and therefore such inclusion and/or use is at the customer's own risk.

**Applications** — Applications that are described herein for any of these products are for illustrative purposes only. NXP Semiconductors makes no representation or warranty that such applications will be suitable for the specified use without further testing or modification.

**Limiting values** — Stress above one or more limiting values (as defined in the Absolute Maximum Ratings System of IEC 60134) may cause permanent damage to the device. Limiting values are stress ratings only and operation of the device at these or any other conditions above those given in the Characteristics sections of this document is not implied. Exposure to limiting values for extended periods may affect device reliability.

**Terms and conditions of sale** — NXP Semiconductors products are sold subject to the general terms and conditions of commercial sale, as published at <http://www.nxp.com/profile/terms>, including those pertaining to warranty, intellectual property rights infringement and limitation of liability, unless explicitly otherwise agreed to in writing by NXP Semiconductors. In case of any inconsistency or conflict between information in this document and such terms and conditions, the latter will prevail.

**No offer to sell or license** — Nothing in this document may be interpreted or construed as an offer to sell products that is open for acceptance or the grant, conveyance or implication of any license under any copyrights, patents or other industrial or intellectual property rights.

### 14.4 Trademarks

Notice: All referenced brands, product names, service names and trademarks are the property of their respective owners.

## 15. Contact information

For additional information, please visit: <http://www.nxp.com>

For sales office addresses, send an email to: [salesaddresses@nxp.com](mailto:salesaddresses@nxp.com)

## 16. Contents

<b>1</b>	<b>Product profile</b> . . . . .	<b>1</b>
1.1	General description . . . . .	1
1.2	Features . . . . .	1
1.3	Applications . . . . .	1
1.4	Quick reference data . . . . .	1
<b>2</b>	<b>Pinning information</b> . . . . .	<b>2</b>
<b>3</b>	<b>Ordering information</b> . . . . .	<b>2</b>
<b>4</b>	<b>Marking</b> . . . . .	<b>2</b>
<b>5</b>	<b>Limiting values</b> . . . . .	<b>3</b>
<b>6</b>	<b>Thermal characteristics</b> . . . . .	<b>3</b>
<b>7</b>	<b>Characteristics</b> . . . . .	<b>4</b>
<b>8</b>	<b>Test information</b> . . . . .	<b>6</b>
<b>9</b>	<b>Package outline</b> . . . . .	<b>6</b>
<b>10</b>	<b>Packing information</b> . . . . .	<b>6</b>
<b>11</b>	<b>Soldering</b> . . . . .	<b>7</b>
<b>12</b>	<b>Mounting</b> . . . . .	<b>7</b>
<b>13</b>	<b>Revision history</b> . . . . .	<b>8</b>
<b>14</b>	<b>Legal information</b> . . . . .	<b>9</b>
14.1	Data sheet status . . . . .	9
14.2	Definitions . . . . .	9
14.3	Disclaimers . . . . .	9
14.4	Trademarks . . . . .	9
<b>15</b>	<b>Contact information</b> . . . . .	<b>9</b>
<b>16</b>	<b>Contents</b> . . . . .	<b>10</b>

Please be aware that important notices concerning this document and the product(s) described herein, have been included in section 'Legal information'.



© NXP B.V. 2006.

All rights reserved.

For more information, please visit: <http://www.nxp.com>

For sales office addresses, please send an email to: [salesaddresses@nxp.com](mailto:salesaddresses@nxp.com)

Date of release: 3 November

Document identifier: BAS21H\_2