

# DATA SHEET

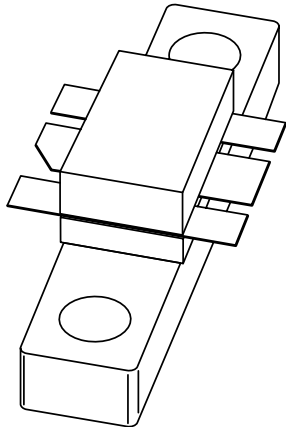

## **BLF544** UHF power MOS transistor

Product specification  
Supersedes data of 1998 Jan 21

2003 Sep 18

# UHF power MOS transistor

# BLF544

### FEATURES

- High power gain
- Easy power control
- Good thermal stability
- Gold metallization ensures excellent reliability
- Designed for broadband operation.

### APPLICATIONS

- Communication transmitters in the UHF frequency range.

### DESCRIPTION

N-channel enhancement mode vertical D-MOS power transistor encapsulated in a 6-lead, SOT171A flange package with a ceramic cap. All leads are isolated from the flange.

A marking code showing gate-source voltage ( $V_{GS}$ ) information is provided for matched pair applications.

### PINNING - SOT171A

PIN	DESCRIPTION
1	source
2	source
3	gate
4	drain
5	source
6	source

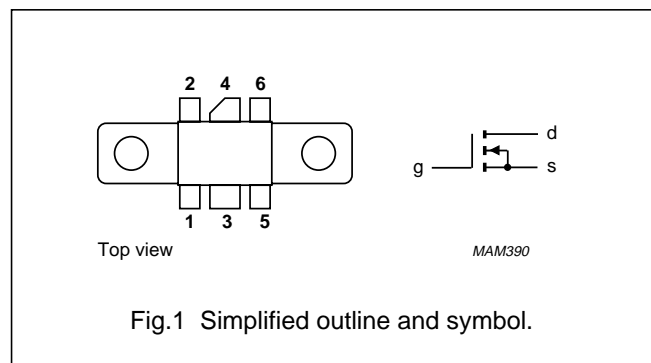

### QUICK REFERENCE DATA

RF performance at  $T_h = 25\text{ }^\circ\text{C}$  in a common source class-B circuit.

MODE OF OPERATION	f (MHz)	$V_{DS}$ (V)	$P_L$ (W)	$G_p$ (dB)	$\eta_D$ (%)
CW, class-B	500	28	20	>11	>50
CW, class-B	960	28	20	typ. 7	typ. 50

### CAUTION

This product is supplied in anti-static packing to prevent damage caused by electrostatic discharge during transport and handling. For further information, refer to Philips specs.: SNW-EQ-608, SNW-FQ-302A and SNW-FQ-302B.

### WARNING

#### Product and environmental safety - toxic materials

This product contains beryllium oxide. The product is entirely safe provided that the BeO disc is not damaged. All persons who handle, use or dispose of this product should be aware of its nature and of the necessary safety precautions. After use, dispose of as chemical or special waste according to the regulations applying at the location of the user. It must never be thrown out with the general or domestic waste.

UHF power MOS transistor

BLF544

**LIMITING VALUES**

In accordance with the Absolute Maximum Rating System (IEC 60134).

SYMBOL	PARAMETER	CONDITIONS	MIN.	MAX.	UNIT
$V_{DS}$	drain-source voltage		–	65	V
$V_{GS}$	gate-source voltage		–	$\pm 20$	V
$I_D$	drain current (DC)		–	3.5	A
$P_{tot}$	total power dissipation	$T_{mb} \leq 25\text{ }^\circ\text{C}$	–	48	W
$T_{stg}$	storage temperature		–65	+150	$^\circ\text{C}$
$T_j$	junction temperature		–	200	$^\circ\text{C}$

**THERMAL CHARACTERISTICS**

SYMBOL	PARAMETER	VALUE	UNIT
$R_{th\ j-mb}$	thermal resistance from junction to mounting base	3.7	K/W
$R_{th\ mb-h}$	thermal resistance from mounting base to heatsink	0.4	K/W

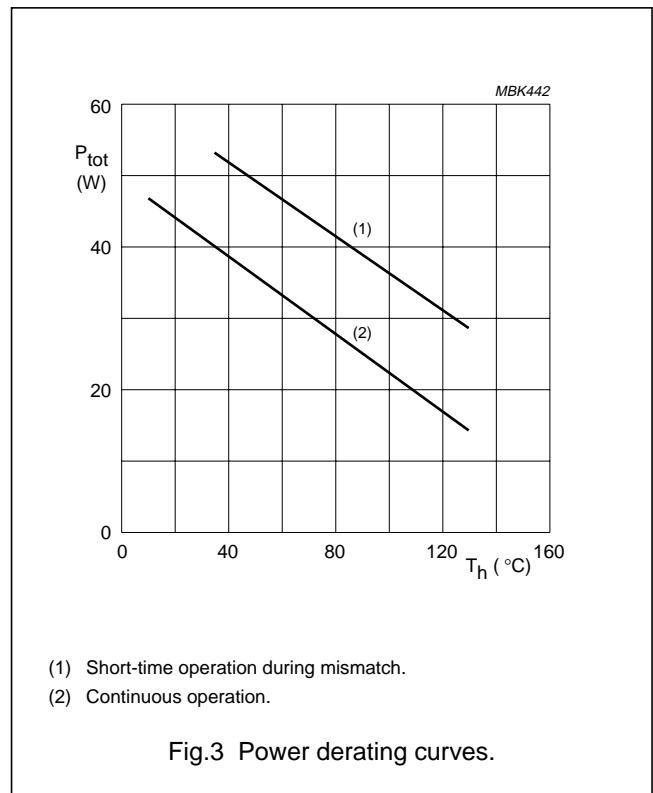
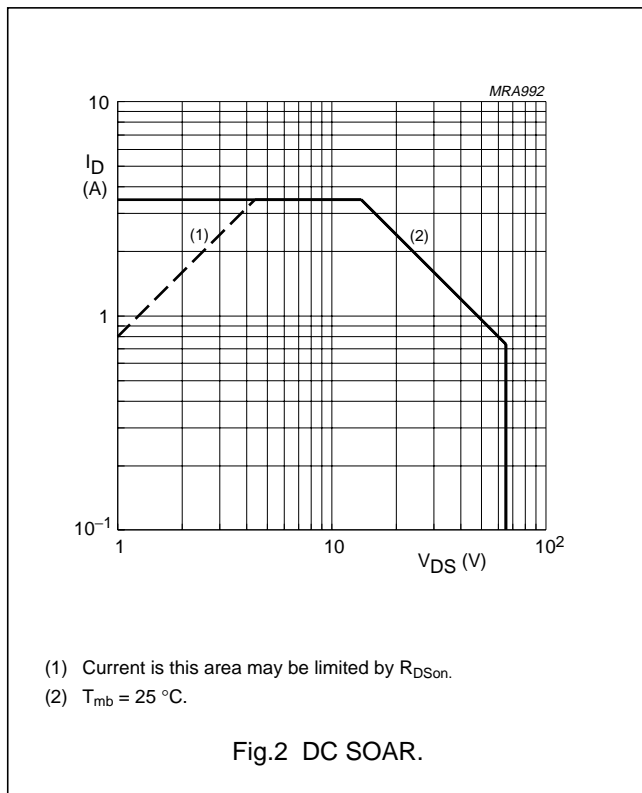

## UHF power MOS transistor

BLF544

**CHARACTERISTICS** $T_j = 25\text{ °C}$  unless otherwise specified.

SYMBOL	PARAMETER	CONDITIONS	MIN.	TYP.	MAX.	UNIT
$V_{(BR)DSS}$	drain-source breakdown voltage	$V_{GS} = 0; I_D = 10\text{ mA}$	65	–	–	V
$I_{DSS}$	drain-source leakage current	$V_{GS} = 0; V_{DS} = 28\text{ V}$	–	–	1	mA
$I_{GSS}$	gate-source leakage current	$V_{GS} = \pm 20\text{ V}; V_{DS} = 0$	–	–	1	$\mu\text{A}$
$V_{GSth}$	gate-source threshold voltage	$I_D = 40\text{ mA}; V_{DS} = 10\text{ V}$	1	–	4	V
$\Delta V_{GSth}$	gate-source voltage difference of matched pairs	$I_D = 40\text{ mA}; V_{DS} = 10\text{ V}$	–	–	100	mV
$g_{fs}$	forward transconductance	$I_D = 1.2\text{ A}; V_{DS} = 10\text{ V}$	600	900	–	mS
$R_{DSon}$	drain-source on-state resistance	$I_D = 1.2\text{ A}; V_{GS} = 10\text{ V}$	–	0.85	1.25	$\Omega$
$I_{DSX}$	on-state drain current	$V_{GS} = 15\text{ V}; V_{DS} = 10\text{ V}$	–	4.8	–	A
$C_{is}$	input capacitance	$V_{GS} = 0; V_{DS} = 28\text{ V}; f = 1\text{ MHz}$	–	32	–	pF
$C_{os}$	output capacitance	$V_{GS} = 0; V_{DS} = 28\text{ V}; f = 1\text{ MHz}$	–	24	–	pF
$C_{rs}$	feedback capacitance	$V_{GS} = 0; V_{DS} = 28\text{ V}; f = 1\text{ MHz}$	–	6.4	–	pF

 **$V_{GS}$  group indicator**

GROUP	LIMITS (V)		GROUP	LIMITS (V)	
	MIN.	MAX.		MIN.	MAX.
A	2.0	2.1	O	3.3	3.4
B	2.1	2.2	P	3.4	3.5
C	2.2	2.3	Q	3.5	3.6
D	2.3	2.4	R	3.6	3.7
E	2.4	2.5	S	3.7	3.8
F	2.5	2.6	T	3.8	3.9
G	2.6	2.7	U	3.9	4.0
H	2.7	2.8	V	4.0	4.1
J	2.8	2.9	W	4.1	4.2
K	2.9	3.0	X	4.2	4.3
L	3.0	3.1	Y	4.3	4.4
M	3.1	3.2	Z	4.4	4.5
N	3.2	3.3			

UHF power MOS transistor

BLF544

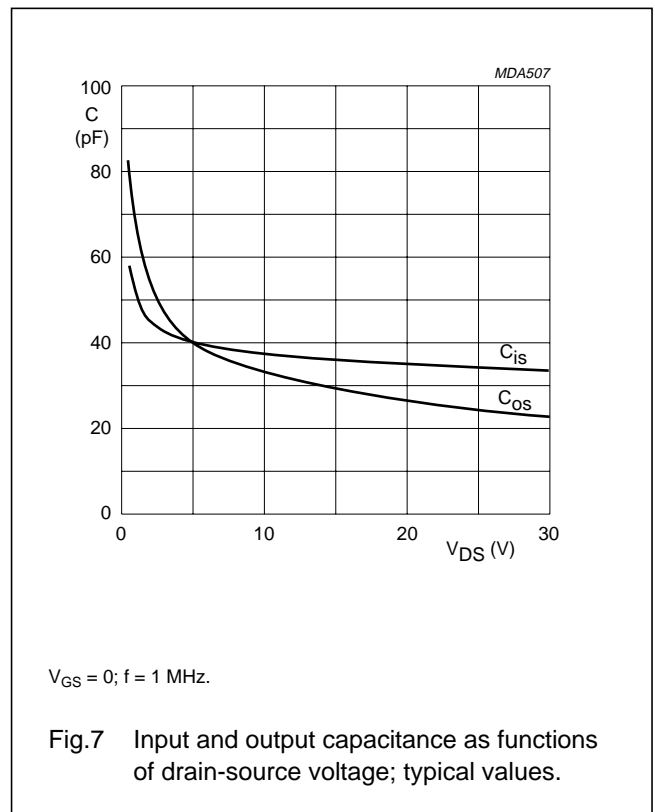
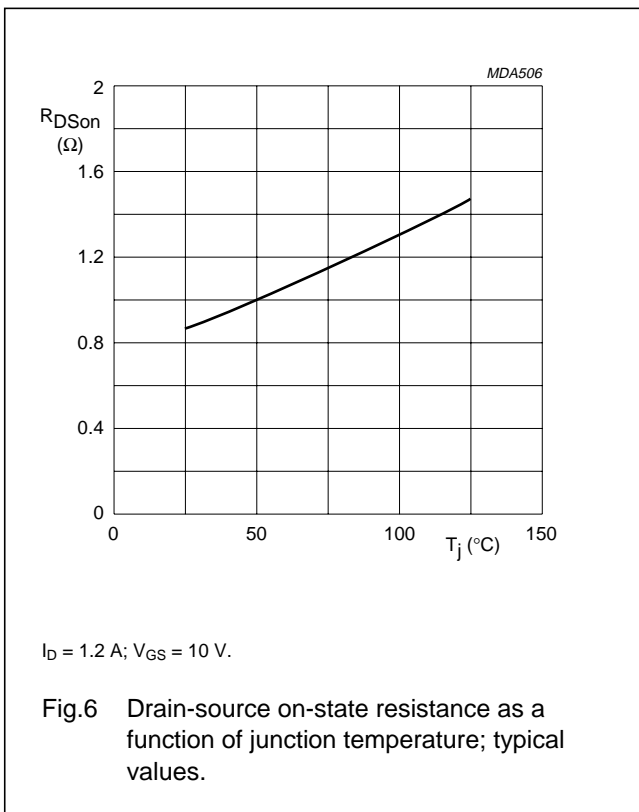
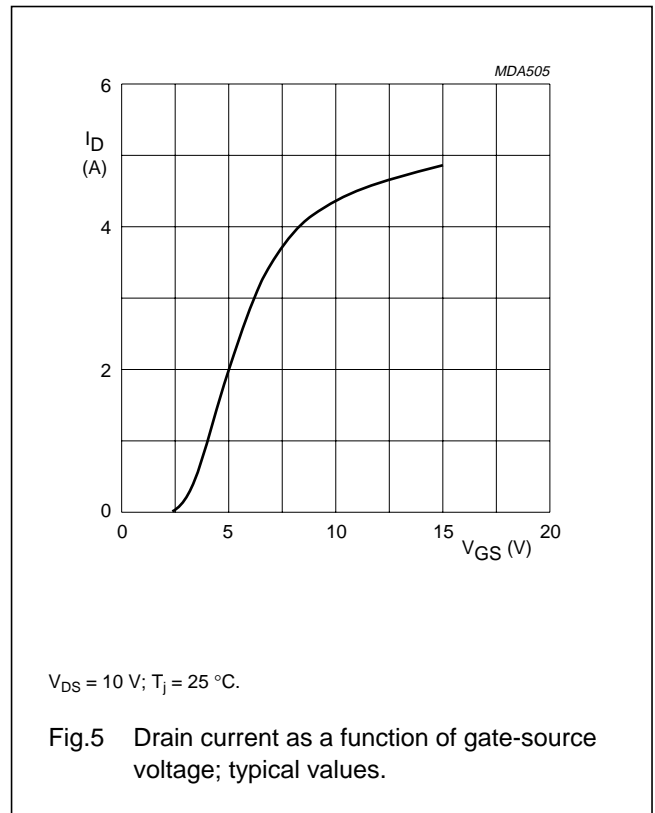
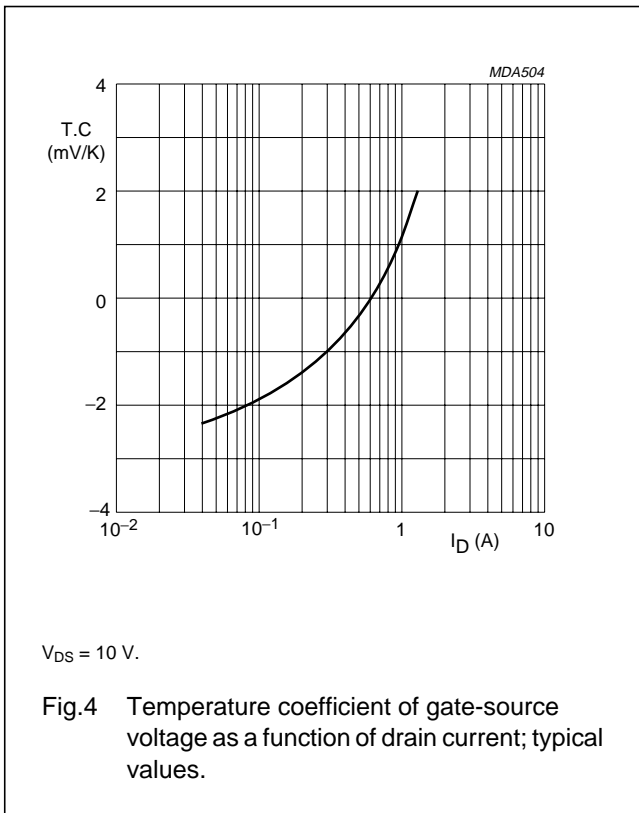

## UHF power MOS transistor

BLF544

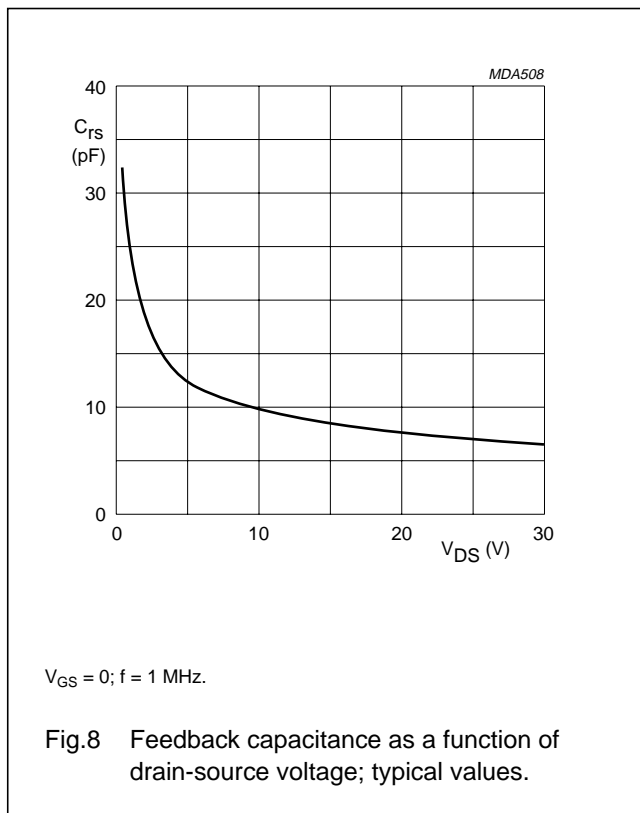
**APPLICATION INFORMATION**

$T_h = 25$  °C;  $R_{th\ mb-h} = 0.4$  K/W unless otherwise specified.

RF performance in a common source class-B circuit.

MODE OF OPERATION	f (MHz)	$V_{DS}$ (V)	$I_{DQ}$ (mA)	$P_L$ (W)	$G_p$ (dB)	$\eta_D$ (%)
CW, class-B	500	28	40	20	>11 typ. 14	>50 typ. 60
CW, class-B	960	28	40	20	typ. 7	typ. 50
CW, class-B	960	24	40	15	typ. 7	typ. 50

**Ruggedness in class-B operation**

The BLF544 is capable of withstanding a full load mismatch corresponding to  $V_{SWR} = 50 : 1$  through all phases under the following conditions:  $V_{DS} = 28$  V;  $f = 500$  MHz at rated output power.

UHF power MOS transistor

BLF544

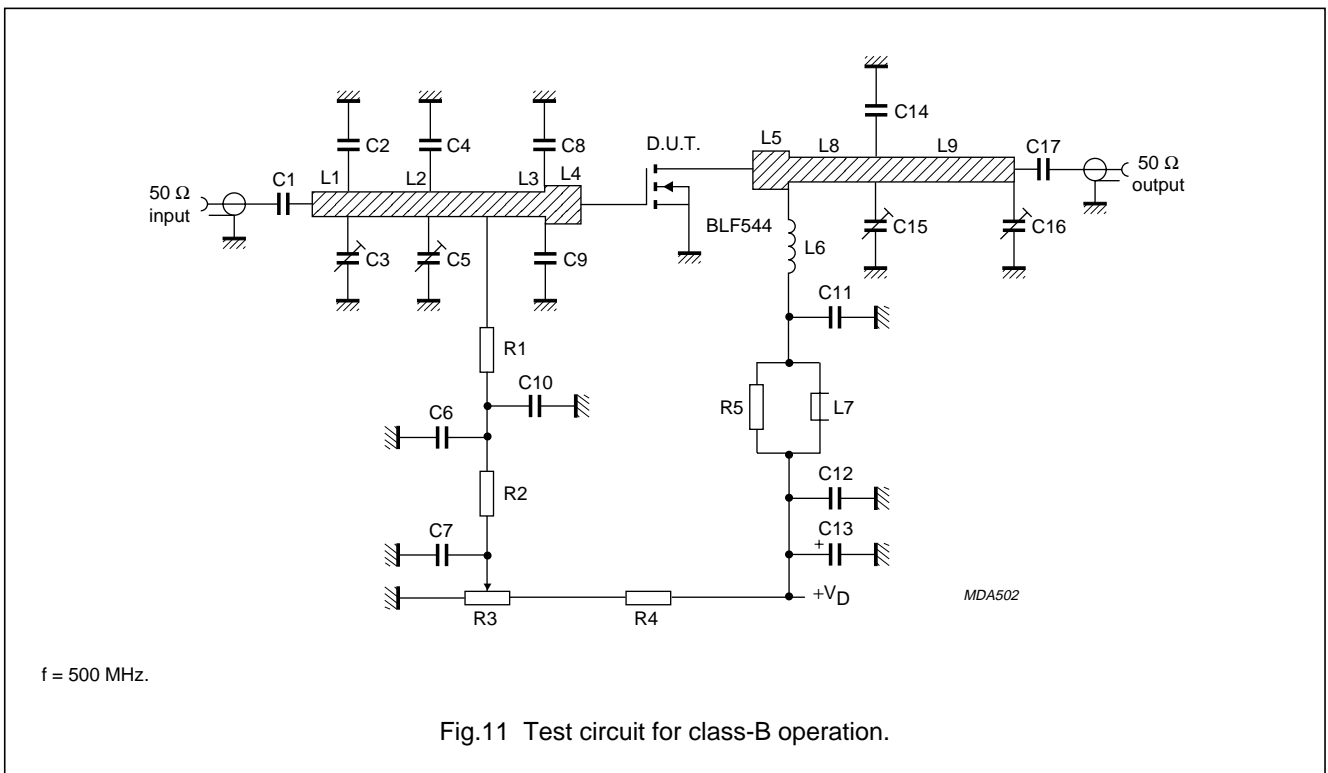
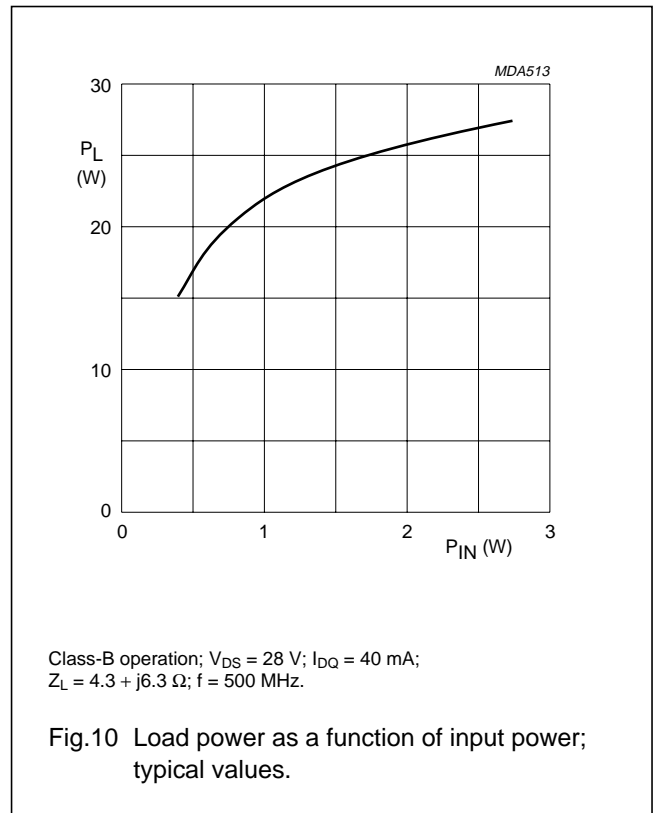
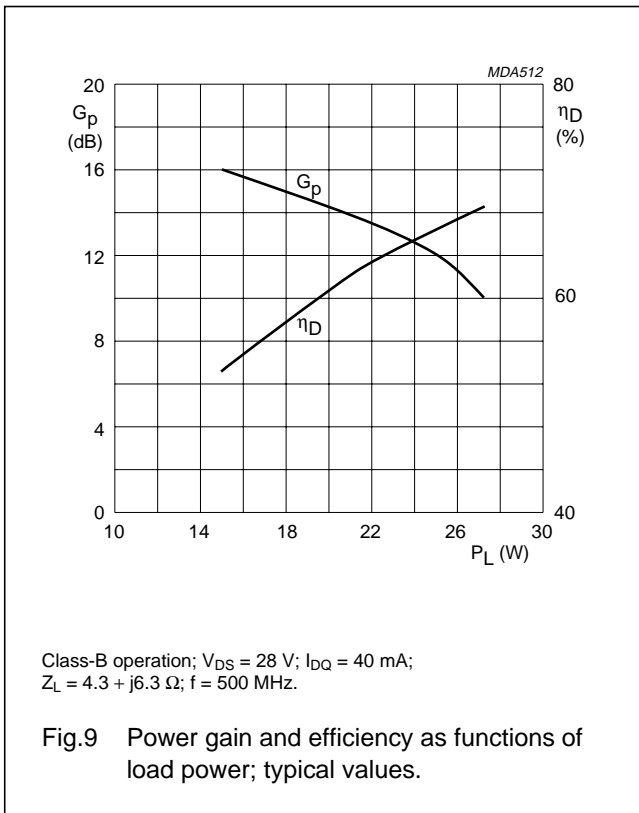

## UHF power MOS transistor

BLF544

List of components (see Figs 11 and 12).

COMPONENT	DESCRIPTION	VALUE	DIMENSIONS	CATALOGUE NO.
C1, C6, C11, C17	multilayer ceramic chip capacitor; note 1	390 pF; 500 V		
C2	multilayer ceramic chip capacitor; note 2	16 pF; 50 V		
C3, C5	film dielectric trimmer	2 to 9 pF		2222 809 09002
C4	multilayer ceramic chip capacitor; note 2	27 pF; 50 V		
C7	multilayer ceramic chip capacitor	2 × 100 nF in parallel; 50 V		2222 852 47104
C8, C9	multilayer ceramic chip capacitor; note 2	39 pF		
C10, C12	multilayer ceramic chip capacitor	100 nF; 50 V		2222 852 47104
C13	electrolytic capacitor	4.7 µF; 63 V		2222 030 38478
C14	multilayer ceramic chip capacitor; note 1	20 pF; 500 V		
C15, C16	film dielectric trimmer	2 to 18 pF		2222 809 09003
L1	stripline note 3	50 Ω	9.5 × 2.5 mm	
L2	stripline note 3	50 Ω	34.5 × 2.5 mm	
L3	stripline note 3	50 Ω	17.5 × 2.5 mm	
L4, L5	stripline note 3	42 Ω	3 × 3 mm	
L6	4 turns enamelled 0.8 mm copper wire	31 nH	length 7.5 mm int. dia. 3 mm leads 2 × 5 mm	
L7	grade 3B Ferroxcube RF choke			4312 020 36642
L8	stripline note 3	50 Ω	22 × 2.5 mm	
L9	stripline note 3	50 Ω	39.5 × 2.5 mm	
R1, R2	0.4 W metal film resistor	1 kΩ		2322 151 11002
R3	10 turns cermet potentiometer	50 kΩ		
R4	0.4 W metal film resistor	140 kΩ		2322 151 11404
R5	1 W metal film resistor	10 Ω		2322 153 51009

## Notes

1. American Technical Ceramics (ATC) capacitor, type 100B or other capacitor of the same quality.
2. American Technical Ceramics (ATC) capacitor, type 100A or other capacitor of the same quality.
3. The striplines are on a double copper-clad printed circuit board, with glass microfibre reinforced PTFE ( $\epsilon_r = 2.2$ ); thickness  $\frac{1}{32}$  inch.

UHF power MOS transistor

BLF544

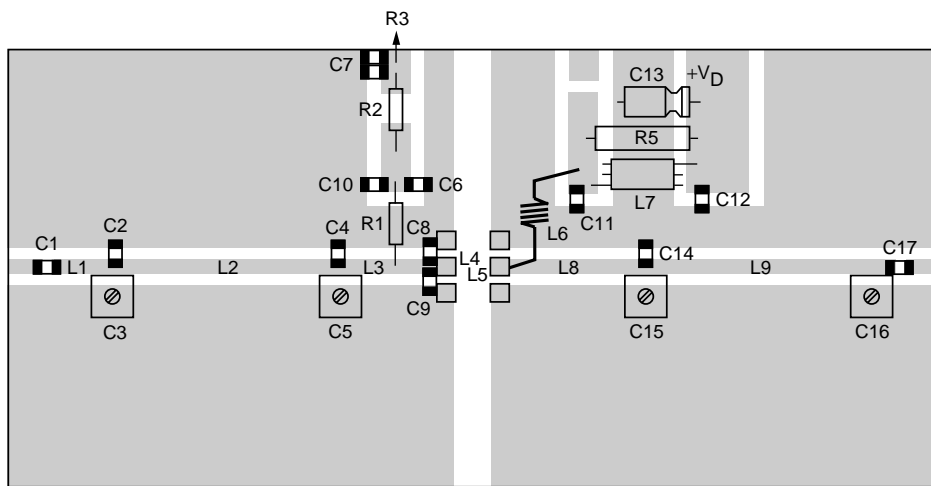
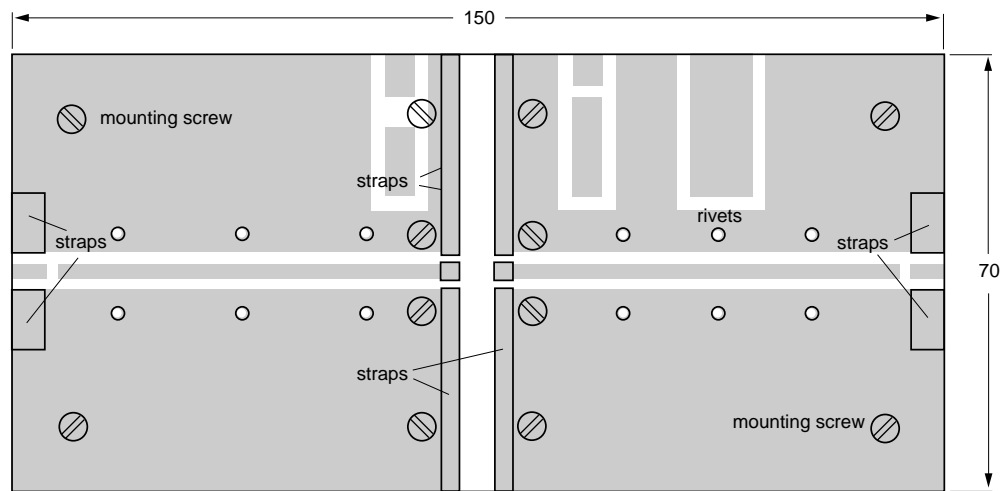

MDA501

Dimensions in mm.

The circuit and components are situated on one side of the printed circuit board, the other side being fully metallized, to serve as a ground plane. Earth connections are made by means of copper straps and hollow rivets for a direct contact between upper and lower sheets.

Fig.12 Component layout for 500 MHz class-B test circuit.

UHF power MOS transistor

BLF544

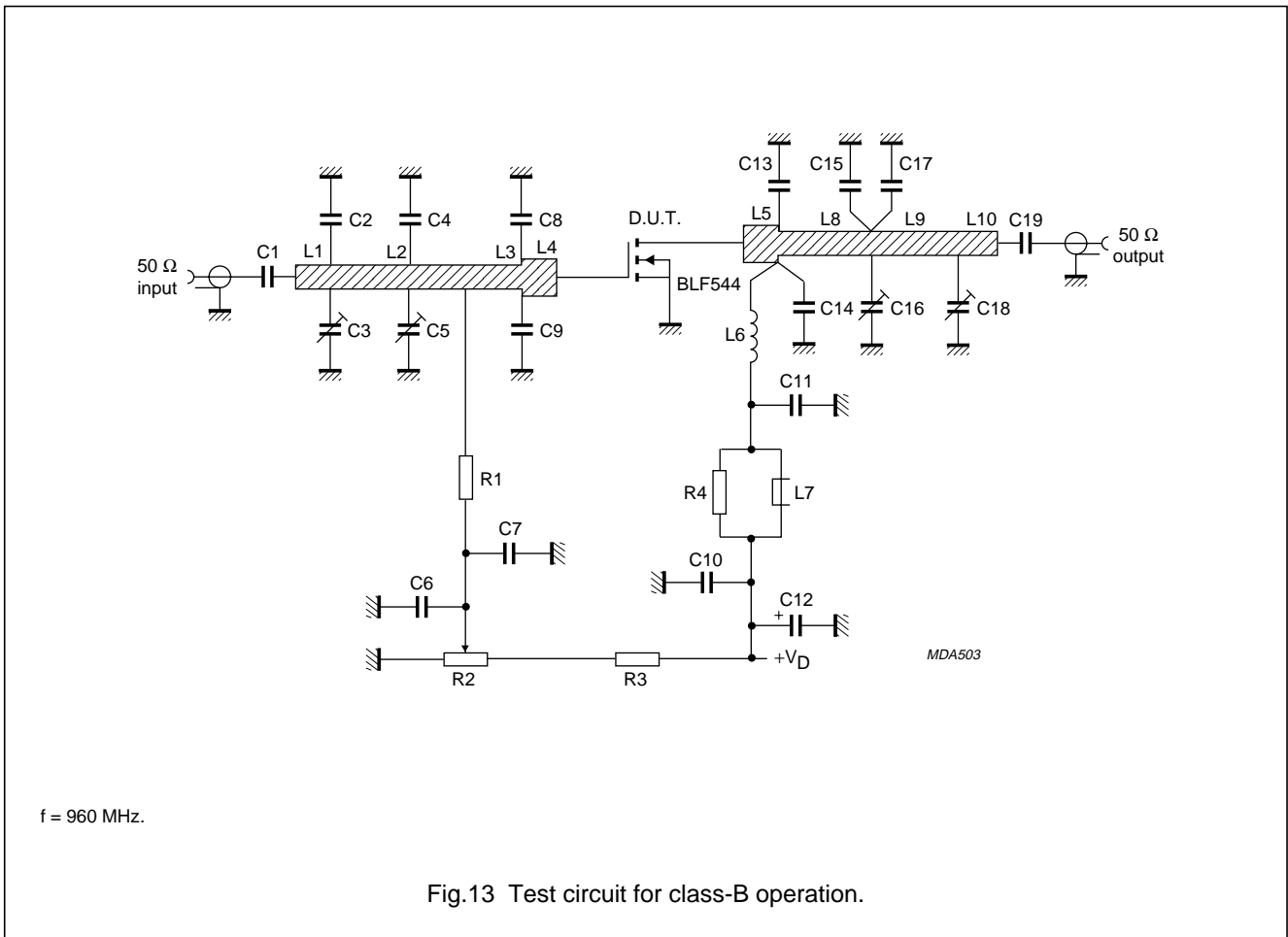

Fig.13 Test circuit for class-B operation.

## UHF power MOS transistor

BLF544

## List of components (see Figs 12 and 13)

COMPONENT	DESCRIPTION	VALUE	DIMENSIONS	CATALOGUE NO.
C1	multilayer ceramic chip capacitor; note 1	68 pF; 500 V		
C2	multilayer ceramic chip capacitor; note 2	1.6 pF; 50 V		
C3, C5, C16, C18	film dielectric trimmer	1.4 to 5.5 pF		2222 809 09001
C4	multilayer ceramic chip capacitor; note 2	1 pF; 50 V		
C6	multilayer ceramic chip capacitor	10 nF; 50 V		2222 852 47103
C7, C11	multilayer ceramic chip capacitor; note 1	56 $\mu$ F; 500 V		
C8, C9, C15, C17	multilayer ceramic chip capacitor; note 2	6.8 $\mu$ F; 50 V		
C10	multilayer ceramic chip capacitor	100 nF; 50 V		2222 852 47104
C12	electrolytic capacitor	4.7 $\mu$ F; 63 V		2222 030 38478
C13	multilayer ceramic chip capacitor; note 2	16 pF; 50 V		
C14	multilayer ceramic chip capacitor; note 2	18 pF; 50 V		
C19	multilayer ceramic chip capacitor; note 1	62 pF; 500 V		
L1, L8	stripline; note 3	50 $\Omega$	6 $\times$ 2.5 mm	
L2	stripline; note 3	50 $\Omega$	38 $\times$ 2.5 mm	
L3	stripline; note 3	50 $\Omega$	17.5 $\times$ 2.5 mm	
L4, L5	stripline; note 3	42 $\Omega$	3 $\times$ 3 mm	
L6	2 turns enamelled 1 mm copper wire	16 nH	length 3.4 mm int. dia. 3 mm leads 2 $\times$ 5 mm	
L7	grade 3B Ferroxcube RF choke			4312 020 36642
L9	stripline; note 3	50 $\Omega$	21 $\times$ 2.5 mm	
L10	stripline; note 3	50 $\Omega$	34.5 $\times$ 2.5 mm	
R1	0.4 W metal film resistor	15 k $\Omega$		2322 151 11473
R2	10 turns potentiometer	50 k $\Omega$		
R3	0.4 W metal film resistor	140 k $\Omega$		2322 151 11404
R4	0.4 W metal film resistor	10 $\Omega$		2322 153 51009

## Notes

1. American Technical Ceramics (ATC) capacitor, type 100B or other capacitor of the same quality.
2. American Technical Ceramics (ATC) capacitor, type 100A or other capacitor of the same quality.
3. The striplines are on a double copper-clad printed-circuit board with glass microfibre reinforced PTFE ( $\epsilon_r = 2.2$ ); thickness  $\frac{1}{32}$  inch.

UHF power MOS transistor

BLF544

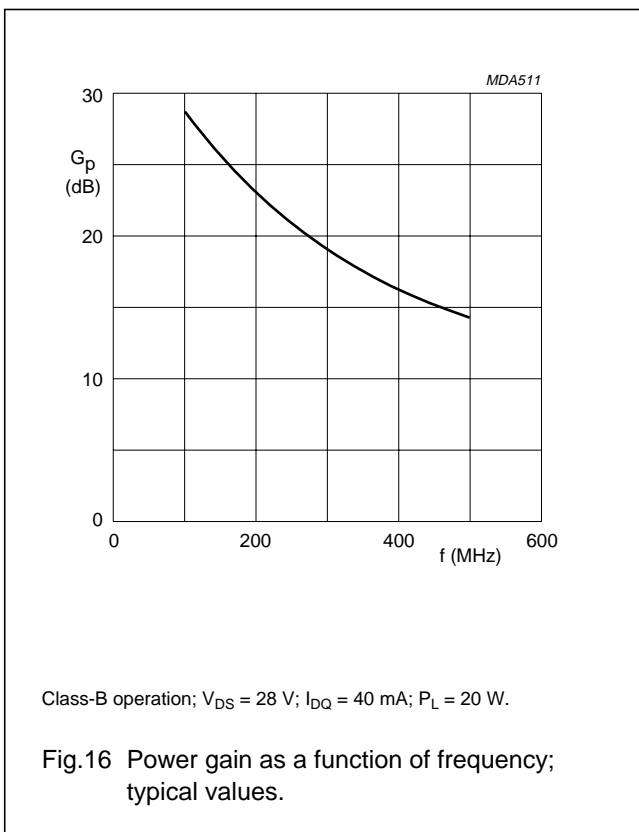
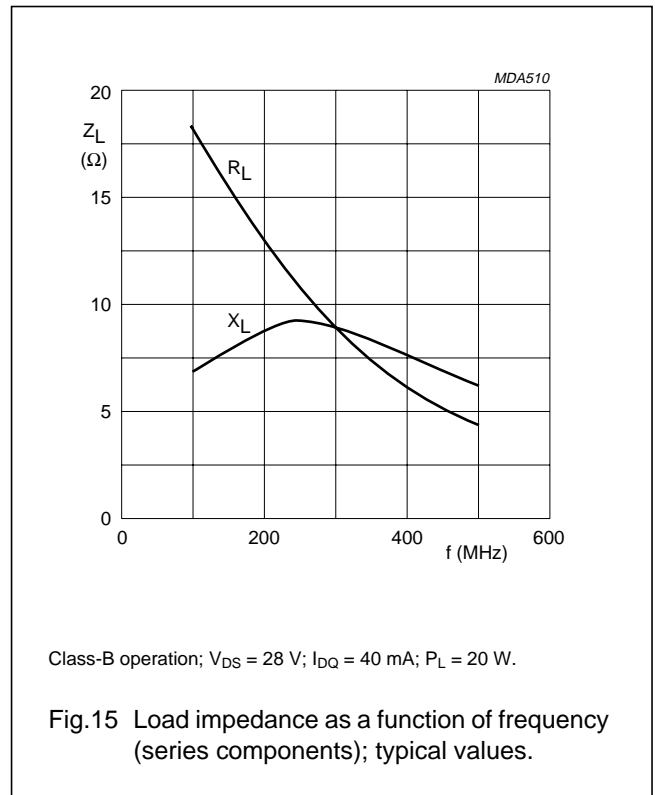
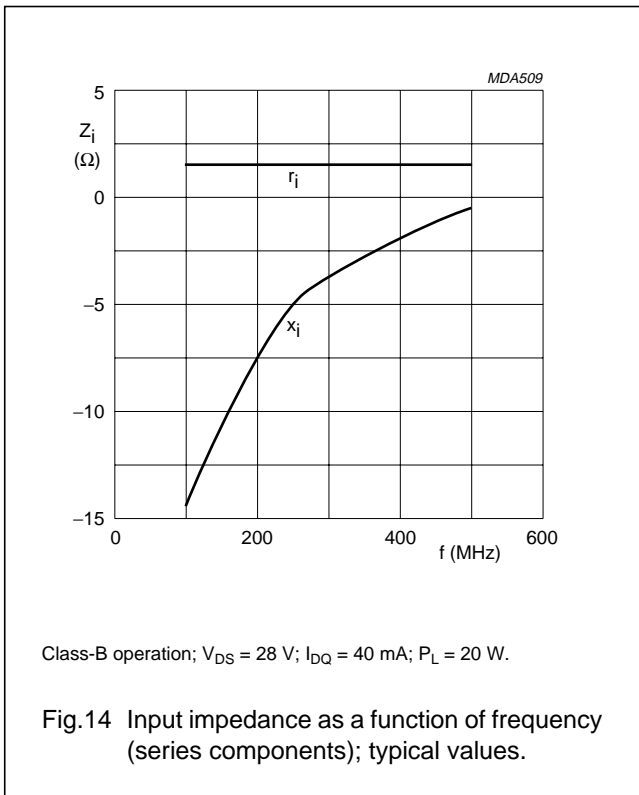

**Optimum input and load impedances**

Optimum input impedance:  $1.2 + j4.8\ \Omega$ .  
 Optimum load impedance:  $2.6 - j3.1\ \Omega$ .  
 Conditions: class-B operation;  $V_{DS} = 24\text{ V}$ ;  
 $I_{DQ} = 40\text{ mA}$ ;  $f = 960\text{ MHz}$ ;  $P_L = 15\text{ W}$ ; typical values.

## UHF power MOS transistor

## BLF544

**BLF544 scattering parameters** $V_{DS} = 28\text{ V}$ ;  $I_D = 40\text{ mA}$ ; note 1

f (MHz)	S <sub>11</sub>		S <sub>21</sub>		S <sub>12</sub>		S <sub>22</sub>	
	S <sub>11</sub>	∠ Φ	S <sub>21</sub>	∠ Φ	S <sub>12</sub>	∠ Φ	S <sub>22</sub>	∠ Φ
5	0.99	-14.0	13.60	171.0	0.02	81.0	0.89	-12.8
10	0.98	-27.6	13.20	162.0	0.04	72.4	0.87	-25.3
20	0.93	-52.0	11.90	146.0	0.07	57.1	0.82	-48.0
30	0.88	-72.0	10.30	134.0	0.09	44.8	0.77	-66.6
40	0.84	-87.7	8.93	124.0	0.10	35.2	0.72	-81.3
50	0.81	-100.0	7.75	116.0	0.11	27.7	0.68	-93.0
60	0.79	-110.0	6.78	110.0	0.12	21.6	0.66	-102.0
70	0.77	-118.0	6.00	104.0	0.12	16.7	0.64	-109.0
80	0.76	-124.0	5.36	99.8	0.12	12.5	0.63	-115.0
90	0.75	-129.0	4.82	95.9	0.12	8.9	0.62	-120.0
100	0.75	-133.0	4.37	92.3	0.13	5.7	0.61	-124.0
125	0.74	-141.0	3.53	84.7	0.13	-1.1	0.61	-131.0
150	0.74	-147.0	2.94	78.3	0.13	-6.6	0.61	-137.0
175	0.74	-151.0	2.50	72.6	0.12	-11.5	0.62	-140.0
200	0.75	-154.0	2.16	67.5	0.12	-15.8	0.64	-143.0
250	0.77	-159.0	1.67	58.4	0.12	-23.3	0.67	-148.0
300	0.78	-163.0	1.33	50.4	0.11	-29.7	0.70	-151.0
350	0.80	-167.0	1.09	43.1	0.10	-35.3	0.73	-154.0
400	0.82	-169.0	0.91	36.6	0.10	-40.3	0.75	-157.0
450	0.84	-172.0	0.77	30.6	0.09	-44.7	0.78	-160.0
500	0.85	-175.0	0.66	25.1	0.08	-48.6	0.80	-162.0
600	0.89	-179.0	0.50	15.6	0.07	-55.2	0.84	-167.0
700	0.90	177.0	0.39	7.5	0.06	-60.4	0.88	-170.0
800	0.92	173.0	0.32	0.6	0.05	-64.3	0.90	-174.0
900	0.93	169.0	0.26	-5.4	0.04	-67.3	0.92	-177.0
1000	0.94	166.0	0.22	-10.8	0.04	-69.2	0.93	-179.0

**Note**

- For more extensive s-parameters see internet:  
<http://www.semiconductors.philips.com/markets/communications/wirelesscommunication/broadcast>.

UHF power MOS transistor

BLF544

PACKAGE OUTLINE

Flanged ceramic package; 2 mounting holes; 6 leads

SOT171A

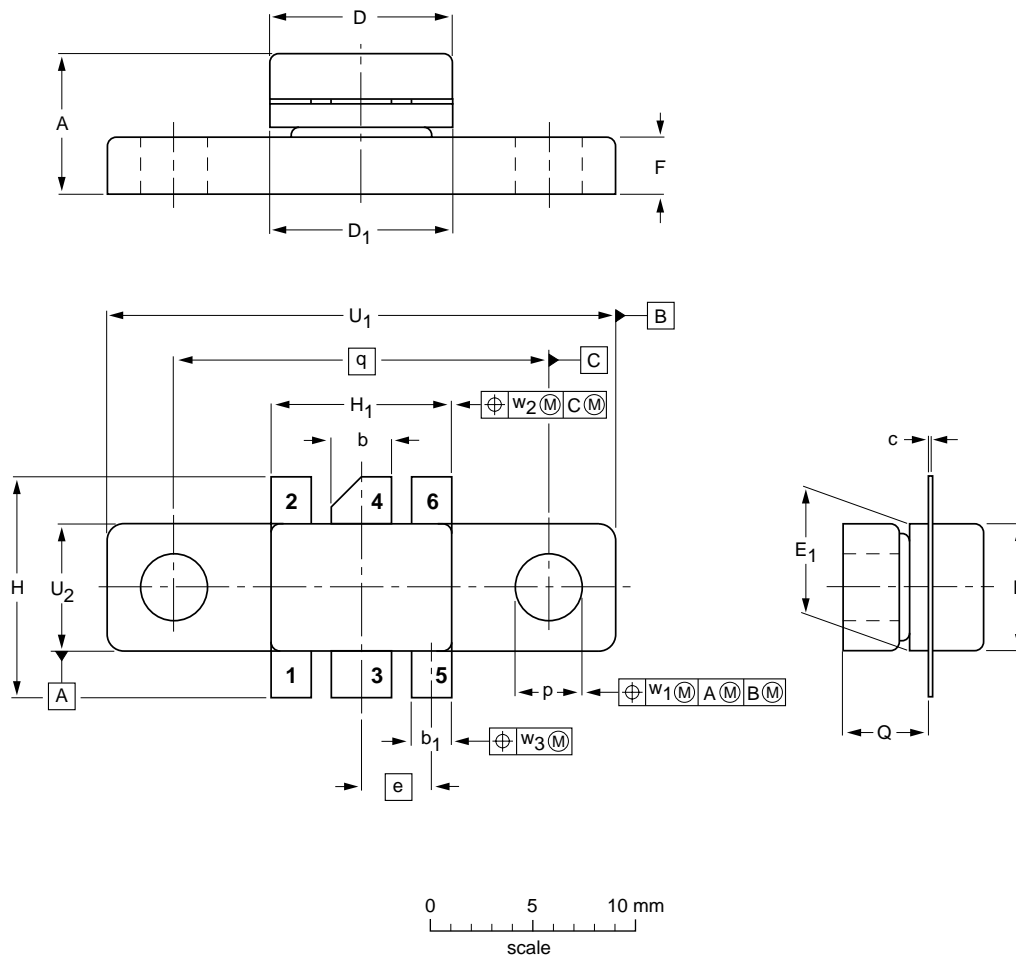

DIMENSIONS (millimetre dimensions are derived from the original inch dimensions)

UNIT	A	b	b <sub>1</sub>	c	D	D <sub>1</sub>	E	E <sub>1</sub>	e	F	H	H <sub>1</sub>	p	Q	q	U <sub>1</sub>	U <sub>2</sub>	w <sub>1</sub>	w <sub>2</sub>	w <sub>3</sub>
mm	6.81 6.07	3.18 2.92	2.13 1.88	0.16 0.07	9.25 9.04	9.27 9.02	5.95 5.74	5.97 5.72	3.58	3.05 2.54	11.31 10.54	9.27 9.01	3.43 3.17	4.32 4.11	18.42	24.90 24.63	5.97 5.72	0.25	0.51	0.25
inches	0.268 0.239	0.125 0.115	0.084 0.074	0.006 0.003	0.364 0.356	0.365 0.355	0.234 0.226	0.235 0.225	0.140	0.120 0.100	0.445 0.415	0.365 0.355	0.135 0.125	0.170 0.162	0.725	0.980 0.970	0.235 0.225	0.010	0.020	0.010

OUTLINE VERSION	REFERENCES				EUROPEAN PROJECTION	ISSUE DATE
	IEC	JEDEC	EIAJ			
SOT171A						99-03-29

## UHF power MOS transistor

BLF544

## DATA SHEET STATUS

LEVEL	DATA SHEET STATUS <sup>(1)</sup>	PRODUCT STATUS <sup>(2)(3)</sup>	DEFINITION
I	Objective data	Development	This data sheet contains data from the objective specification for product development. Philips Semiconductors reserves the right to change the specification in any manner without notice.
II	Preliminary data	Qualification	This data sheet contains data from the preliminary specification. Supplementary data will be published at a later date. Philips Semiconductors reserves the right to change the specification without notice, in order to improve the design and supply the best possible product.
III	Product data	Production	This data sheet contains data from the product specification. Philips Semiconductors reserves the right to make changes at any time in order to improve the design, manufacturing and supply. Relevant changes will be communicated via a Customer Product/Process Change Notification (CPCN).

## Notes

1. Please consult the most recently issued data sheet before initiating or completing a design.
2. The product status of the device(s) described in this data sheet may have changed since this data sheet was published. The latest information is available on the Internet at URL <http://www.semiconductors.philips.com>.
3. For data sheets describing multiple type numbers, the highest-level product status determines the data sheet status.

## DEFINITIONS

**Short-form specification** — The data in a short-form specification is extracted from a full data sheet with the same type number and title. For detailed information see the relevant data sheet or data handbook.

**Limiting values definition** — Limiting values given are in accordance with the Absolute Maximum Rating System (IEC 60134). Stress above one or more of the limiting values may cause permanent damage to the device. These are stress ratings only and operation of the device at these or at any other conditions above those given in the Characteristics sections of the specification is not implied. Exposure to limiting values for extended periods may affect device reliability.

**Application information** — Applications that are described herein for any of these products are for illustrative purposes only. Philips Semiconductors make no representation or warranty that such applications will be suitable for the specified use without further testing or modification.

## DISCLAIMERS

**Life support applications** — These products are not designed for use in life support appliances, devices, or systems where malfunction of these products can reasonably be expected to result in personal injury. Philips Semiconductors customers using or selling these products for use in such applications do so at their own risk and agree to fully indemnify Philips Semiconductors for any damages resulting from such application.

**Right to make changes** — Philips Semiconductors reserves the right to make changes in the products - including circuits, standard cells, and/or software - described or contained herein in order to improve design and/or performance. When the product is in full production (status 'Production'), relevant changes will be communicated via a Customer Product/Process Change Notification (CPCN). Philips Semiconductors assumes no responsibility or liability for the use of any of these products, conveys no licence or title under any patent, copyright, or mask work right to these products, and makes no representations or warranties that these products are free from patent, copyright, or mask work right infringement, unless otherwise specified.

# ***Philips Semiconductors – a worldwide company***

## **Contact information**

For additional information please visit <http://www.semiconductors.philips.com>. Fax: +31 40 27 24825

For sales offices addresses send e-mail to: [sales.addresses@www.semiconductors.philips.com](mailto:sales.addresses@www.semiconductors.philips.com).

© Koninklijke Philips Electronics N.V. 2003

SCA75

All rights are reserved. Reproduction in whole or in part is prohibited without the prior written consent of the copyright owner.

The information presented in this document does not form part of any quotation or contract, is believed to be accurate and reliable and may be changed without notice. No liability will be accepted by the publisher for any consequence of its use. Publication thereof does not convey nor imply any license under patent- or other industrial or intellectual property rights.

Printed in The Netherlands

613524/03/pp16

Date of release: 2003 Sep 18

Document order number: 9397 750 11589

*Let's make things better.*

**Philips  
Semiconductors**



**PHILIPS**