

CBT16212

24-bit bus exchange switch with 12-bit output enables

Rev. 02 — 3 November 2008

Product data sheet

1. General description

The CBT16212 provides 24 bits of high-speed TTL-compatible bus switching or exchanging. The low ON resistance of the switch allows connections to be made with minimal propagation delay.

The CBT16212 operates either as a 24-bit bus switch or as a 12-bit bus exchanger, providing data exchange between four signal ports using the port select inputs (S0, S1 and S2).

The CBT16212 is characterized for operation from $-40\text{ }^{\circ}\text{C}$ to $+85\text{ }^{\circ}\text{C}$.

2. Features

- $5\ \Omega$ switch connection between two ports
- TTL compatible input levels
- ESD protection:
 - ◆ HBM JESD22-A114E Class 1C exceeds 1500 V
 - ◆ CDM JESD22-C101C exceeds 1000 V
- Latch-up performance:
 - ◆ JESD78 exceeds 100 mA

3. Ordering information

Table 1. Ordering information

Type number	Package			
	Temperature range	Name	Description	Version
CBT16212DGG	$-40\text{ }^{\circ}\text{C}$ to $85\text{ }^{\circ}\text{C}$	TSSOP56	plastic thin shrink small outline package; 56 leads; body width 6.1 mm	SOT364-1
CBT16212DL	$-40\text{ }^{\circ}\text{C}$ to $85\text{ }^{\circ}\text{C}$	SSOP56	plastic shrink small outline package; 56 leads; body width 7.5 mm	SOT371-1

4. Functional diagram

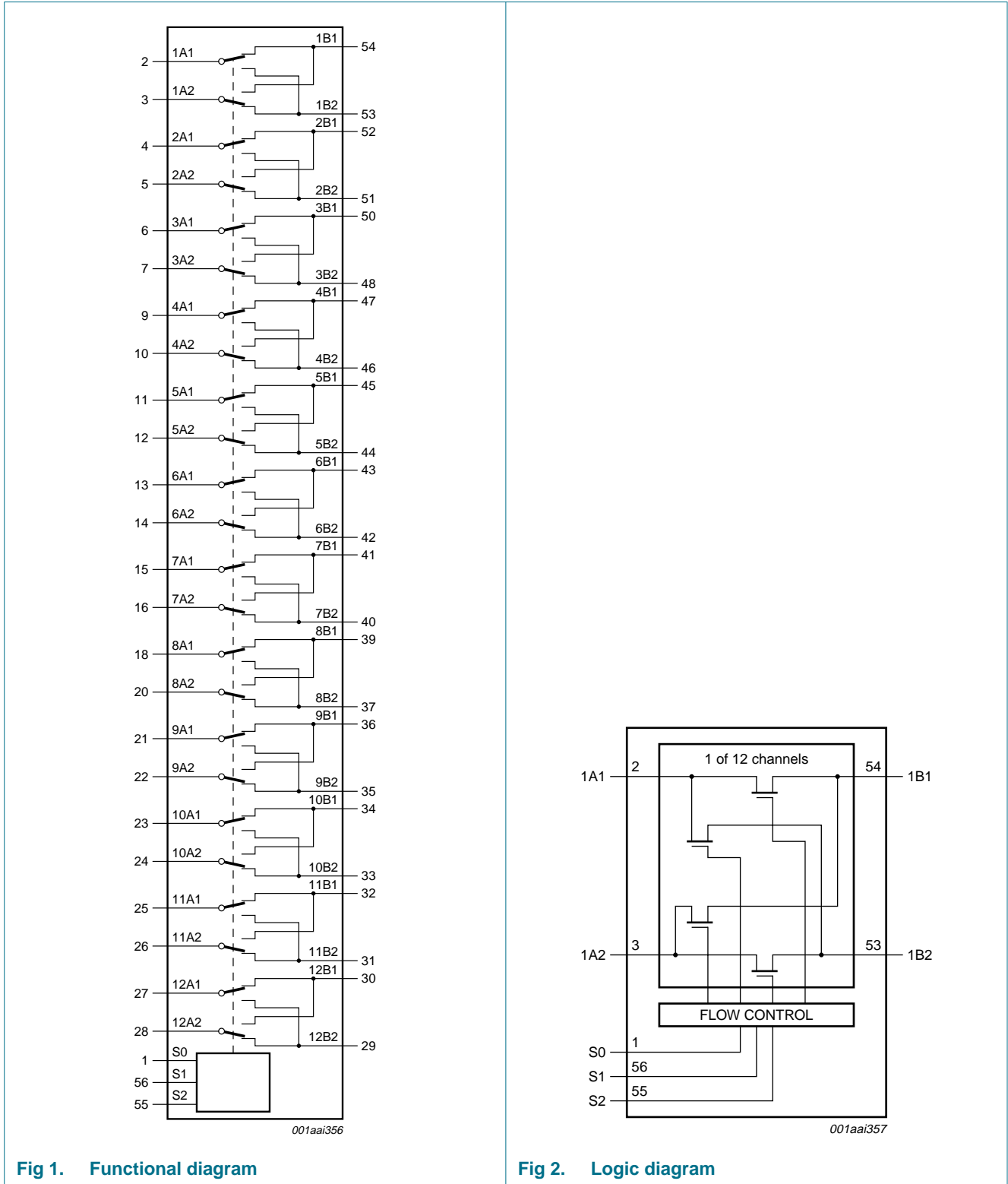

Fig 1. Functional diagram

Fig 2. Logic diagram

5. Pinning information

5.1 Pinning

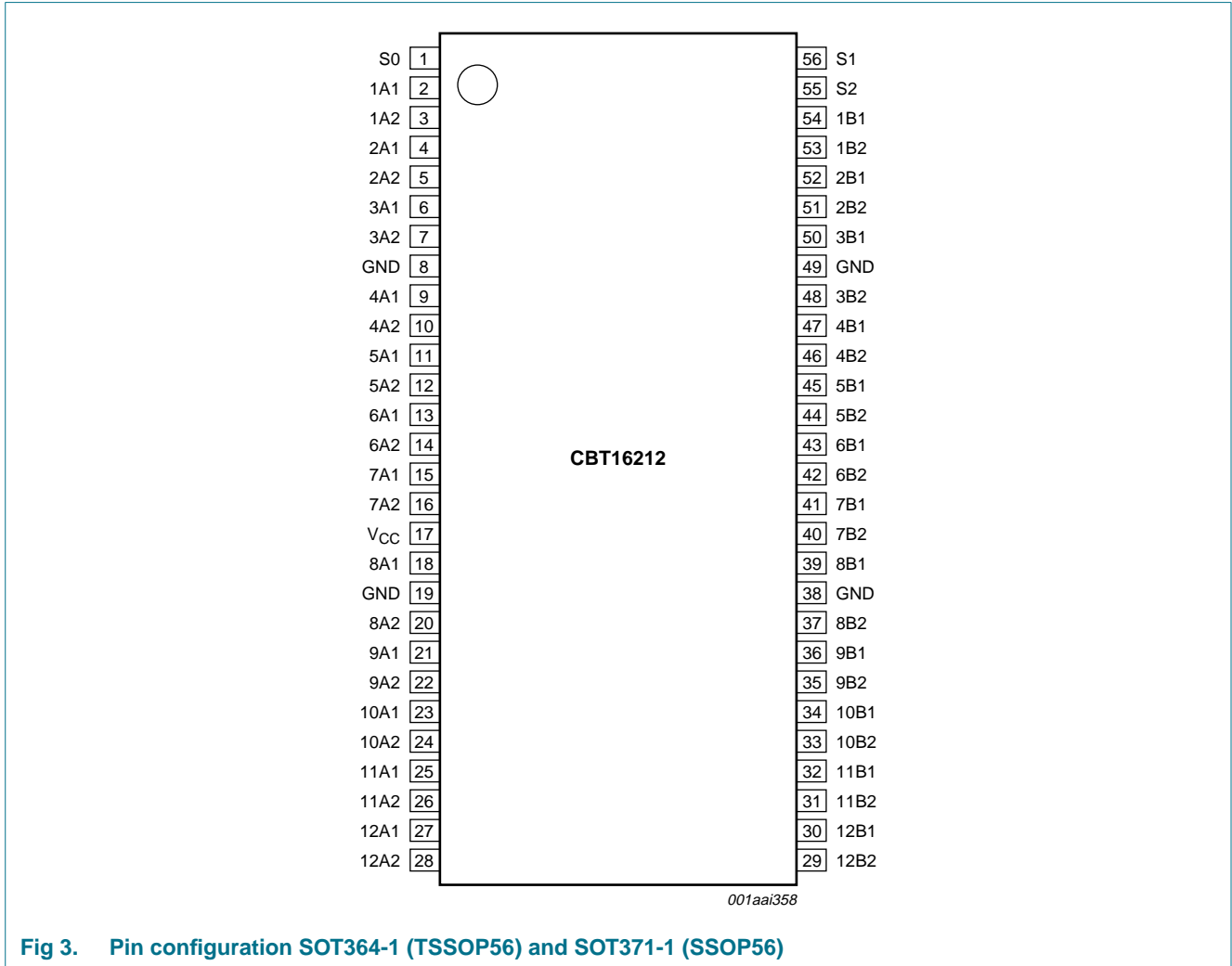

Fig 3. Pin configuration SOT364-1 (TSSOP56) and SOT371-1 (SSOP56)

5.2 Pin description

Table 2. Pin description

Symbol	Pin	Description
S0, S1, S2	1, 56, 55	port select input
1A1 to 12A1	2, 4, 6, 9, 11, 13, 15, 18, 21, 23, 25, 27	A1 port
1A2 to 12A2	3, 5, 7, 10, 12, 14, 16, 20, 22, 24, 26, 28	A2 port
GND	8, 19, 38, 49	ground (0 V)
V _{CC}	17	supply voltage
1B1 to 12B1	54, 52, 50, 47, 45, 43, 41, 39, 36, 34, 32, 30	B1 port
1B2 to 12B2	53, 51, 48, 46, 44, 42, 40, 37, 35, 33, 31, 29	B2 port

6. Functional description

Table 3. Function selection^[1]

Port select input			Input/output		Function
S2	S1	S0	nA1	nA2	
L	L	L	Z	Z	disconnect
L	L	H	nB1	Z	nA1 = nB1
L	H	L	nB2	Z	nA1 = nB2
L	H	H	Z	nB1	nA2 = nB1
H	L	L	Z	nB2	nA2 = nB2
H	L	H	Z	Z	disconnect
H	H	L	nB1	nB2	nA1 = nB1 and nA2 = nB2
H	H	H	nB2	nB1	nA1 = nB2 and nA2 = nB1

[1] H = HIGH voltage level; L = LOW voltage level; Z = high-impedance OFF-state.

7. Limiting values

Table 4. Limiting values

In accordance with the Absolute Maximum Rating System (IEC 60134).

Symbol	Parameter	Conditions	Min	Max	Unit
V _{CC}	supply voltage		-0.5	+7.0	V
V _I	input voltage		^[1] -0.5	+7.0	V
I _{IK}	input clamping current	V _I < 0 V	-50	-	mA
V _O	output voltage	output at HIGH level or OFF-state	-0.5	+5.5	V
I _O	output current	output at LOW level	-	128	mA
T _{stg}	storage temperature		-65	+150	°C
P _{tot}	total power dissipation	T _{amb} = -40 °C to +125 °C			
		SSOP56 package	^[3] -	850	mW
		TSSOP56 package	^[4] -	600	mW

- [1] The input and output voltage ratings may be exceeded if the input and output current ratings are observed.
- [2] The performance capability of a high-performance integrated circuit in conjunction with its thermal environment can create junction temperatures which are detrimental to reliability. The maximum junction temperature of this integrated circuit should not exceed 150 °C.
- [3] Above 55 °C the value of P_{tot} derates linearly with 11.3 mW/K.
- [4] Above 55 °C the value of P_{tot} derates linearly with 8 mW/K.

8. Recommended operating conditions

Table 5. Operating conditions

All unused control inputs of the device must be held at V_{CC} or GND to ensure proper device operation.

Symbol	Parameter	Conditions	Min	Max	Unit
V _{CC}	supply voltage		4.0	5.5	V
V _{IH}	HIGH-level input voltage		2.0	-	V
V _{IL}	LOW-level input voltage		-	0.8	V
T _{amb}	ambient temperature	operating in free-air	-40	+85	°C

9. Static characteristics

Table 6. Static characteristics

$T_{amb} = -40\text{ }^{\circ}\text{C}$ to $+85\text{ }^{\circ}\text{C}$.

Symbol	Parameter	Conditions	Min	Typ ^[1]	Max	Unit	
V_{IK}	input clamping voltage	$V_{CC} = 4.5\text{ V}$; $I_I = -18\text{ mA}$	-	-	-1.2	V	
I_I	input leakage current	$V_{CC} = 0\text{ V}$; $V_I = 5.5\text{ V}$	-	-	10	μA	
		$V_{CC} = 5.5\text{ V}$; $V_I = V_{CC}$ or GND	-	-	± 1	μA	
I_{CC}	supply current	$V_{CC} = 5.5\text{ V}$; $I_O = 0\text{ A}$; $V_I = V_{CC}$ or GND	-	-	3	μA	
ΔI_{CC}	additional supply current	per port select input pin; $V_{CC} = 5.5\text{ V}$; ^[2] one input at 3.4 V, other inputs at V_{CC} or GND	-	-	2.5	mA	
C_I	input capacitance	port select input pins; $V_I = 3\text{ V}$ or 0 V ; $V_{CC} = 5.0\text{ V}$;	-	4.7	-	pF	
$C_{io(off)}$	off-state input/output capacitance	$V_O = 3\text{ V}$ or 0 V ; $V_{CC} = 0\text{ V}$	-	11.5	-	pF	
R_{ON}	ON resistance	$V_{CC} = 4.0\text{ V}$ ^[3]	-	-	-	-	
		$V_I = 2.4\text{ V}$; $I_I = 15\text{ mA}$	-	-	21	Ω	
		$V_{CC} = 4.5\text{ V}$ ^[3]	-	-	-	-	-
		$V_I = 0\text{ V}$; $I_I = 64\text{ mA}$	-	4	7	Ω	
		$V_I = 0\text{ V}$; $I_I = 30\text{ mA}$	-	4	7	Ω	
		$V_I = 2.4\text{ V}$; $I_I = 15\text{ mA}$	-	6	12	Ω	

[1] All typical values are measured at $T_{amb} = 25\text{ }^{\circ}\text{C}$.

[2] This is the increase in supply current for each input that is at the specified TTL voltage level rather than V_{CC} or GND.

[3] Measured by the voltage drop between the A and the B terminals at the indicated current through the switch. ON resistance is determined by the lowest voltage of the two (A or B) terminals.

10. Dynamic characteristics

Table 7. Dynamic characteristics

$T_{amb} = -40\text{ }^{\circ}\text{C}$ to $+85\text{ }^{\circ}\text{C}$; $V_{CC} = 4.5\text{ V}$ to 5.5 V ; for test circuit see [Figure 6](#).

Symbol	Parameter	Conditions	Min	Max	Unit
t_{pd}	propagation delay	input A or B to output B or A; see Figure 4 ^{[1][2]}	-	0.25	ns
t_{en}	enable time	port select input to output A or B; Figure 5 ^[3]	2.4	8.0	ns
t_{dis}	disable time	port select input to output A or B; Figure 5 ^[4]	2.4	8.0	ns

[1] This parameter is warranted but not production tested. The propagation delay is based on the RC time constant of the typical ON resistance of the switch and a load capacitance of 50 pF, when driven by an ideal voltage source (zero output impedance).

[2] t_{pd} is the same as t_{PLH} and t_{PHL} .

[3] t_{en} is the same as t_{PZL} and t_{PZH} .

[4] t_{dis} is the same as t_{PLZ} and t_{PHZ} .

11. Waveforms

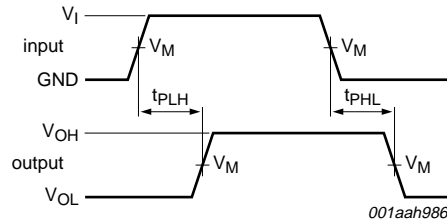

Measurement points are given in [Table 8](#).
 V_{OL} and V_{OH} are typical output voltage levels that occur with the output load.

Fig 4. Input to output propagation delays

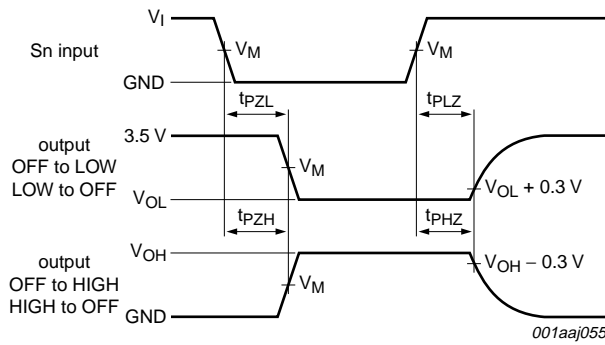

Measurement points are given in [Table 8](#).
 V_{OL} and V_{OH} are typical output voltage levels that occur with the output load.

Fig 5. Enable and disable times

Table 8. Measurement points

Supply voltage	Input	Output
V_{CC}	V_M	V_M
4.5 V to 5.5 V	1.5 V	1.5 V

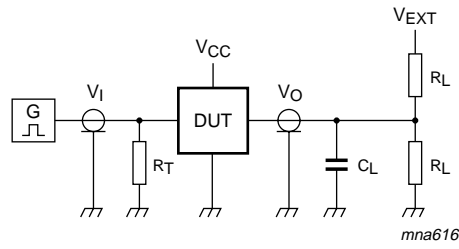

Test data is given in [Table 9](#).

Definitions for test circuit:

R_L = Load resistance.

C_L = Load capacitance including jig and probe capacitance.

R_T = Termination resistance should be equal to the output impedance Z_o of the pulse generator.

V_{EXT} = External voltage for measuring switching times.

Fig 6. Test circuit

Table 9. Test data

Supply voltage	Input		Load		V_{EXT}		
V_{CC}	V_I	$t_r = t_f$	C_L	R_L	t_{PLH}, t_{PHL}	t_{PZH}, t_{PHZ}	t_{PZL}, t_{PLZ}
4.5 V to 5.5 V	GND to 3.0 V	≤ 2.5 ns	50 pF	500 Ω	open	open	7.0 V

12. Package outline

TSSOP56: plastic thin shrink small outline package; 56 leads; body width 6.1 mm

SOT364-1

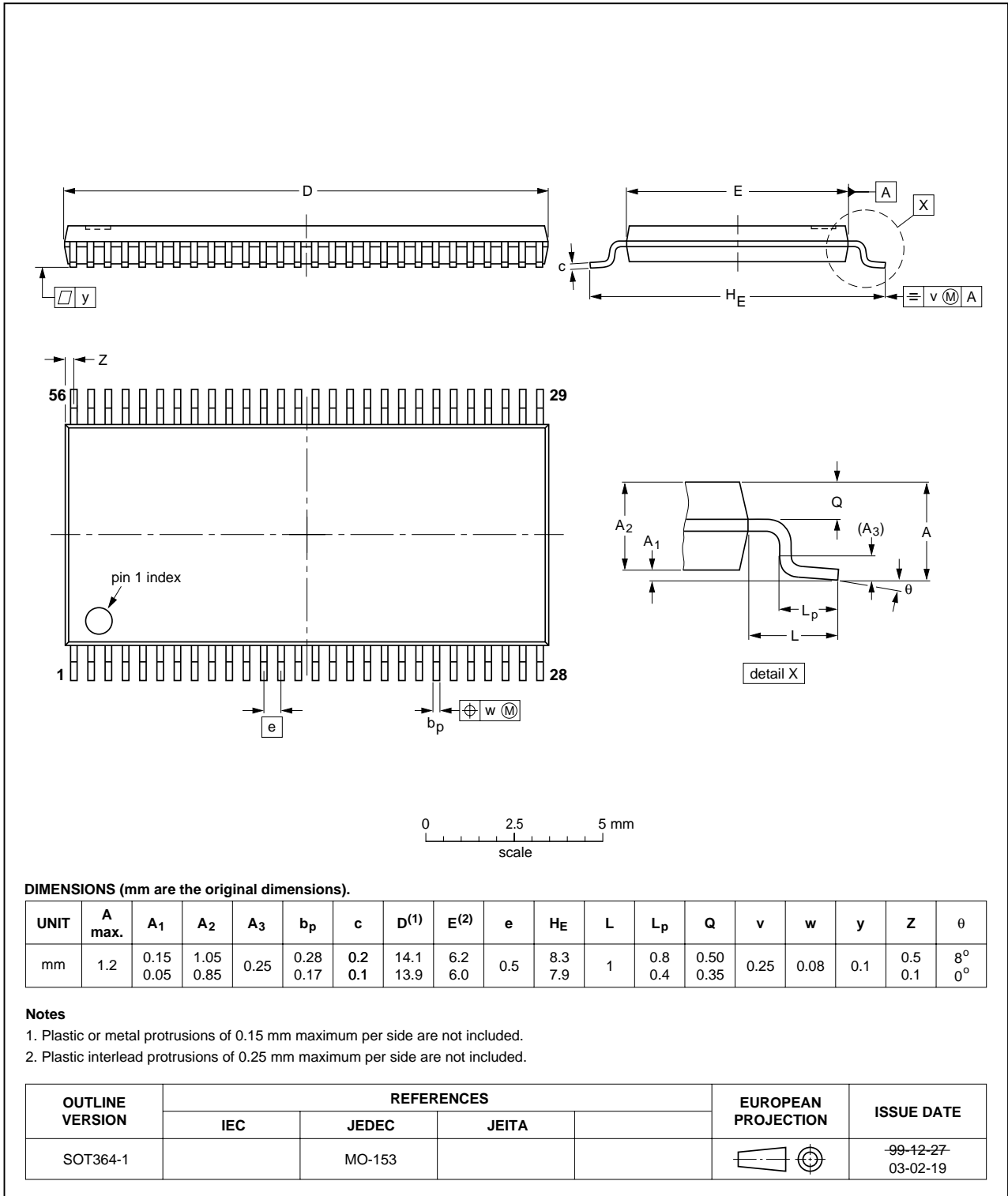

Fig 7. Package outline SOT364-1 (TSSOP56)

SSOP56: plastic shrink small outline package; 56 leads; body width 7.5 mm

SOT371-1

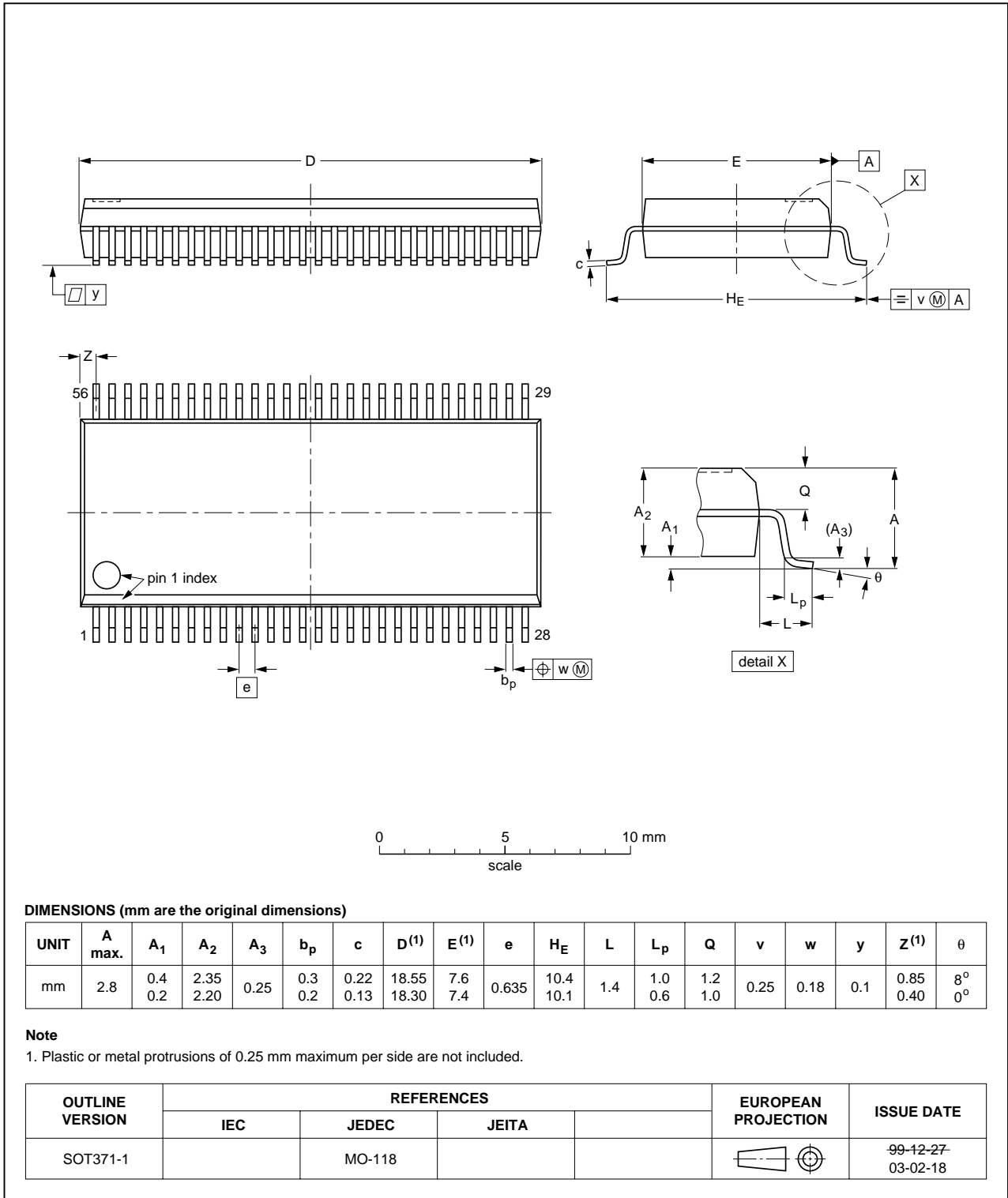

Fig 8. Package outline SOT371-1 (SSOP56)

13. Abbreviations

Table 10. Abbreviations

Acronym	Description
CDM	Charged Device Model
DUT	Device Under Test
ESD	ElectroStatic Discharge
HBM	Human Body Model
TTL	Transistor-Transistor Logic

14. Revision history

Table 11. Revision history

Document ID	Release date	Data sheet status	Change notice	Supersedes
CBT16212_2	03112008	Product data sheet	-	CBT16212_1
Modifications:		<ul style="list-style-type: none">• The format of this data sheet has been redesigned to comply with the new identity guidelines of NXP Semiconductors.• Legal texts have been adapted to the new company name where appropriate.• Table 7 “Dynamic characteristics”:<ul style="list-style-type: none">– Enable time: min value changed from 3.6 into 2.4.– Disable time: min value changed from 4.5 into 2.4.		
CBT16212_1	20010928	Product data	-	-

15. Legal information

15.1 Data sheet status

Document status ^{[1][2]}	Product status ^[3]	Definition
Objective [short] data sheet	Development	This document contains data from the objective specification for product development.
Preliminary [short] data sheet	Qualification	This document contains data from the preliminary specification.
Product [short] data sheet	Production	This document contains the product specification.

[1] Please consult the most recently issued document before initiating or completing a design.

[2] The term 'short data sheet' is explained in section "Definitions".

[3] The product status of device(s) described in this document may have changed since this document was published and may differ in case of multiple devices. The latest product status information is available on the Internet at URL <http://www.nxp.com>.

15.2 Definitions

Draft — The document is a draft version only. The content is still under internal review and subject to formal approval, which may result in modifications or additions. NXP Semiconductors does not give any representations or warranties as to the accuracy or completeness of information included herein and shall have no liability for the consequences of use of such information.

Short data sheet — A short data sheet is an extract from a full data sheet with the same product type number(s) and title. A short data sheet is intended for quick reference only and should not be relied upon to contain detailed and full information. For detailed and full information see the relevant full data sheet, which is available on request via the local NXP Semiconductors sales office. In case of any inconsistency or conflict with the short data sheet, the full data sheet shall prevail.

15.3 Disclaimers

General — Information in this document is believed to be accurate and reliable. However, NXP Semiconductors does not give any representations or warranties, expressed or implied, as to the accuracy or completeness of such information and shall have no liability for the consequences of use of such information.

Right to make changes — NXP Semiconductors reserves the right to make changes to information published in this document, including without limitation specifications and product descriptions, at any time and without notice. This document supersedes and replaces all information supplied prior to the publication hereof.

Suitability for use — NXP Semiconductors products are not designed, authorized or warranted to be suitable for use in medical, military, aircraft, space or life support equipment, nor in applications where failure or

malfunction of an NXP Semiconductors product can reasonably be expected to result in personal injury, death or severe property or environmental damage. NXP Semiconductors accepts no liability for inclusion and/or use of NXP Semiconductors products in such equipment or applications and therefore such inclusion and/or use is at the customer's own risk.

Applications — Applications that are described herein for any of these products are for illustrative purposes only. NXP Semiconductors makes no representation or warranty that such applications will be suitable for the specified use without further testing or modification.

Limiting values — Stress above one or more limiting values (as defined in the Absolute Maximum Ratings System of IEC 60134) may cause permanent damage to the device. Limiting values are stress ratings only and operation of the device at these or any other conditions above those given in the Characteristics sections of this document is not implied. Exposure to limiting values for extended periods may affect device reliability.

Terms and conditions of sale — NXP Semiconductors products are sold subject to the general terms and conditions of commercial sale, as published at <http://www.nxp.com/profile/terms>, including those pertaining to warranty, intellectual property rights infringement and limitation of liability, unless explicitly otherwise agreed to in writing by NXP Semiconductors. In case of any inconsistency or conflict between information in this document and such terms and conditions, the latter will prevail.

No offer to sell or license — Nothing in this document may be interpreted or construed as an offer to sell products that is open for acceptance or the grant, conveyance or implication of any license under any copyrights, patents or other industrial or intellectual property rights.

15.4 Trademarks

Notice: All referenced brands, product names, service names and trademarks are the property of their respective owners.

16. Contact information

For more information, please visit: <http://www.nxp.com>

For sales office addresses, please send an email to: salesaddresses@nxp.com

17. Contents

1 General description 1

2 Features 1

3 Ordering information 1

4 Functional diagram 2

5 Pinning information 3

5.1 Pinning 3

5.2 Pin description 3

6 Functional description 4

7 Limiting values 4

8 Recommended operating conditions 4

9 Static characteristics 5

10 Dynamic characteristics 5

11 Waveforms 6

12 Package outline 8

13 Abbreviations 10

14 Revision history 10

15 Legal information 11

15.1 Data sheet status 11

15.2 Definitions 11

15.3 Disclaimers 11

15.4 Trademarks 11

16 Contact information 11

17 Contents 12

Please be aware that important notices concerning this document and the product(s) described herein, have been included in section 'Legal information'.



© NXP B.V. 2008.

All rights reserved.

For more information, please visit: <http://www.nxp.com>

For sales office addresses, please send an email to: salesaddresses@nxp.com

Date of release: 3 November 2008

Document identifier: CBT16212_2