

GENERAL DESCRIPTION

The 3003 is a common base transistor capable of providing 3 watts of CW RF output power at 3000 MHz. This hermetically sealed transistor is specifically designed for telemetry and telecommunications applications. It utilizes gold metallization and diffused ballasting to provide high reliability and extreme ruggedness.

3003
3 WATTS - 28 VOLTS
3000 MHz

MICROWAVE CW BIPOLAR

ABSOLUTE MAXIMUM RATINGS

Maximum Power Dissipation @ 25°C Case Temperature 10 W

Maximum Voltage and Current
 BV_{ces} Collector to Emitter Voltage 50 V
 BV_{ebo} Emitter to Base Voltage 3.5 V
 I_c Collector Current 0.6 A

Maximum Temperatures
 Storage Temperature -65 to +200 °C
 Operating Junction Temperature +200 °C

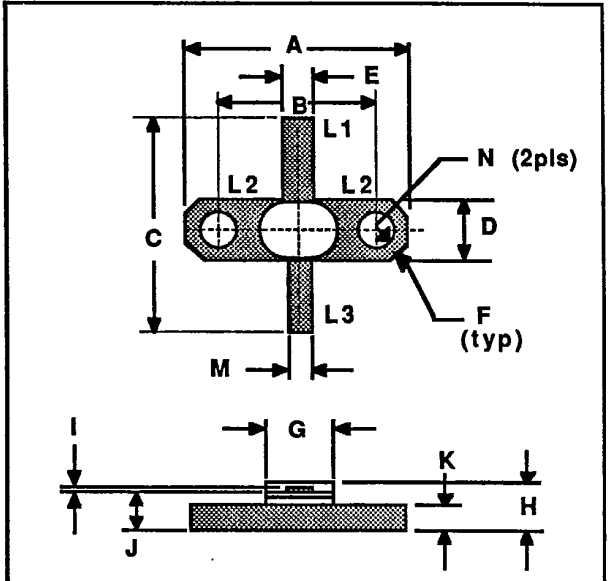

L1 : B	DIM	Millimeter	TOL	Inches	TOL
L2 : E	A	20.32	.13	.800	.005
L3 : C	B	14.27	.13	.562	.005
	C	18.03	MIN	.710	MIN
	D	5.84	.13	.230	.005
	E	3.05	.13	.120	.005
	F	45°	5°	45°	5°
	G	5.84	.13	.230	.005
	H	4.57	REF	.180	REF
	I	0.13	.02	.005	.001
	J	3.81	.13	.150	.005
	K	1.52	.13	.060	.005
	M	1.27	.13	.050	.005
	N	3.30	.13	.130	.005

POWER OUTPUT VS POWER INPUT VS FREQUENCY (TYPICAL)

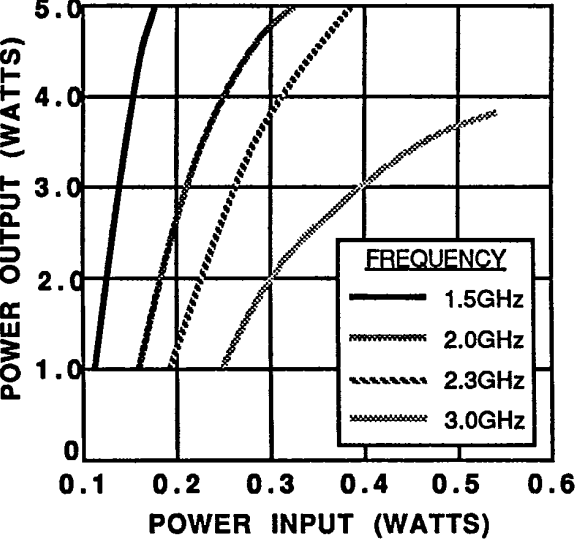

TYPICAL AMPLIFIER LINE UP
 V_{cc} = 28 Volts
 Frequency Range = 3000 MHz

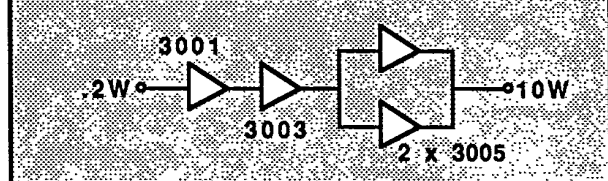

3003-2

ELECTRICAL CHARACTERISTICS¹

SYMBOL	CHARACTERISTICS	TEST CONDITIONS	MIN.	TYP.	MAX.	UNITS
P _{out}	Power Output	f = 3.0 GHz V _{cc} = 28V	3.0			Watts
P _{in}	Power Input				0.75	Watts
P _g	Power Gain			6.0		dB
η _c	Collector Efficiency			30		%
VSWR	Load Mismatch Tolerance					∞:1
BV _{ebo}	Breakdown Voltage (Emitter to Base)	I _c = 0A, I _e = 3mA	3.5			Volts
BV _{ces}	Breakdown Voltage (Collector to Emitter)	V _{be} = 0A, I _c = 30mA	50			Volts
I _{cbo}	Collector Leakage Current	I _e = 0A, V _{cb} = 28V			1.5	mA
C _{ob}	Capacitance-Collector to Base	f = 1.0MHz, V _{cb} = 28V		7.0		pF
h _{FE}	DC-Current Gain	V _{ce} = 5V, I _c = 300mA	10			
θ _{jc}	Thermal Resistance	T _c = 25°C			17	°C/W

Note 1: T_c = +25°C unless otherwise specified

SATURATED POWER OUTPUT VS FREQUENCY (TYPICAL)

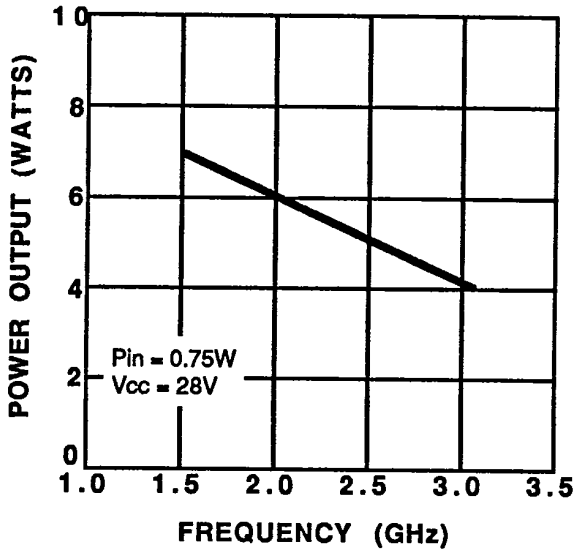

EFFICIENCY VS FREQUENCY (TYPICAL)

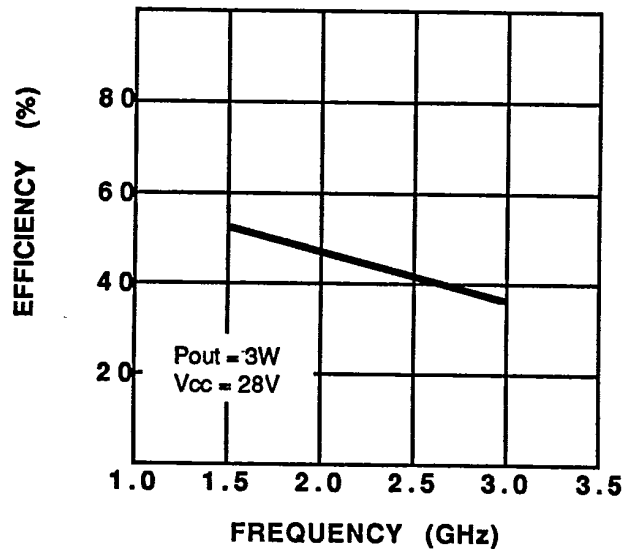

SPECIFICATIONS MAY BE SUBJECT TO CHANGE WITHOUT NOTICE

458

3003-3

3003 TEST AMPLIFIER

f = 3000 MHz

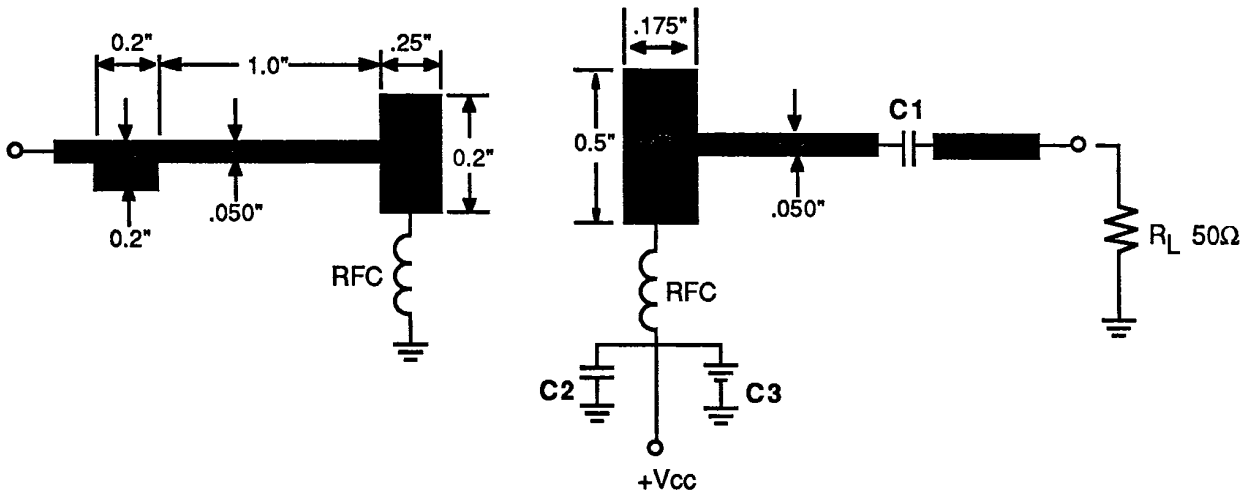

--- MICROSTRIP ON 0.020 TEFLON FIBERGLASS, $\epsilon_r = 2.55$
 C1, C2 --- ATC 'A' 47 pf
 C3 --- 10 μ fd @ 35 Volts

**SMITH CHART
3003**

NORMALIZED IMPEDANCE AND ADMITTANCE COORDINATES

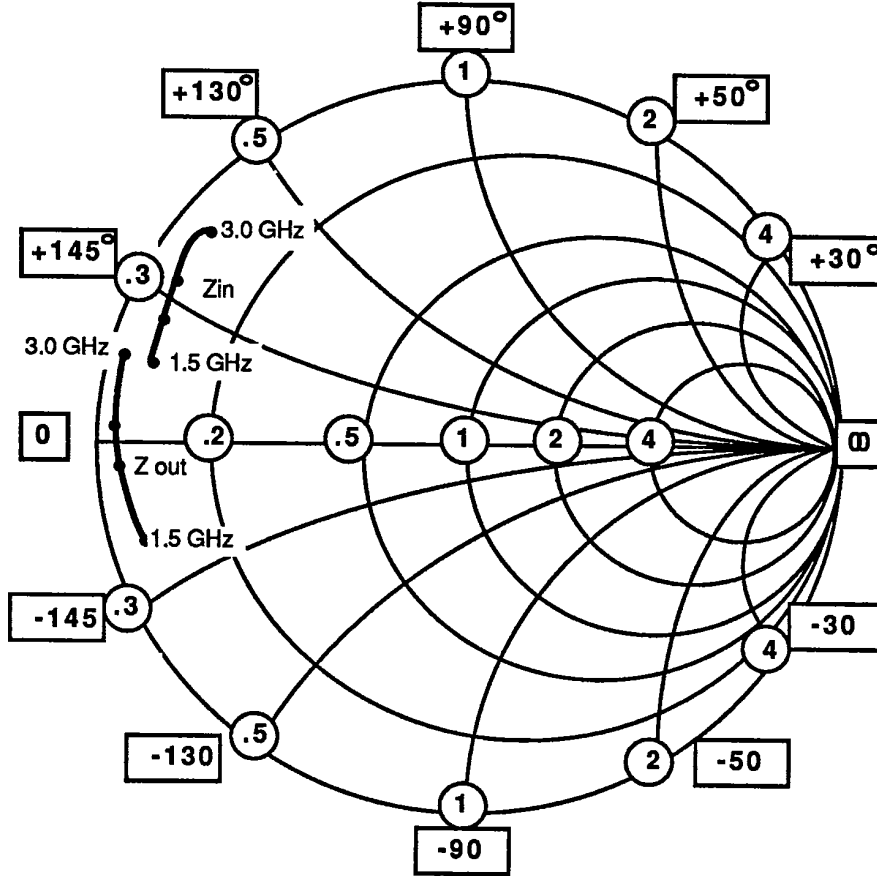

NORMALIZED TO A 50 OHM SYSTEM.

FREQUENCY MHz	R	Zin jX	FREQUENCY MHz	R	Zload jX
1500	3.8	8.0	1500	3.7	10
2000	3.6	13	2000	3.3	3.0
2300	3.4	17	2300	3.2	-3.0
3000	3.4	20	3000	2.7	-9.0

260