



CMOS LOW VOLTAGE, LOW CHARGE INJECTION QUAD SPST ANALOG SWITCHES

GENERAL DESCRIPTION

The ALD4201/ALD4202M are quad SPSTCMOS analog switches specifically developed for 3 to 12 volt applications where low charge injection and low leakage currents are important analog switch operating characteristics. The main features are precision matching, charge compensation circuitry, fast switching, low on-resistance and micropower consumption. The ALD4201 operates in break-before-make switching whereas the ALD4202M operates in make-before-break switching.

The ALD4201/ALD4202M are designed for precision applications such as charge amplifiers, sample and hold amplifiers, data converter switches, and programmable gain amplifiers. These switches are also excellent for general purpose switching applications for micropower battery operated systems.

APPLICATIONS INFORMATION

The ALD4201/ALD4202M are designed to operate with standard single or dual power supplies of +3V to 10V or $\pm 1.5V$ to $\pm 5V$. Functionality extends down to +2V or $\pm 1V$ power supply, making it suitable for lithium battery or rechargeable battery operated systems where power efficiency and performance are important design parameters. These switches feature nA quiescent current and interface directly to CMOS logic levels from microprocessor or logic interface circuits. Built-in level shifters at the input stage provide for dual supply analog signal switching. On the board level, low charge injection and fast operation can be obtained by using short leads, minimizing input and output capacitances, and by adequate bypass capacitors placed on the board at the supply nodes. For more information, see Application Note AN4200.

The ALD4201/4202M are manufactured with Advanced Linear Devices' enhanced ACMOS silicon gate CMOS process, and are also part of the linear elements in Advanced Linear Devices' "Function-Specific" ASIC.

ORDERING INFORMATION

Operating Temperature Range		
-55°C to +125°C	0°C to +70°C	0°C to +70°C
16-Pin CERDIP Package	16-Pin Plastic Dip Package	16-Pin SOIC Package
ALD4201 DC ALD4202M DC	ALD4201 PC ALD4202M PC	ALD4201 SC ALD4202M SC

LOGIC TABLE

Input Logic	Switch State	
	ALD4201	ALD4202M
0	On	Off
1	Off	On

* Contact factory for industrial temperature range.

FEATURES

- 3V, 5V & 10V supply operation
- $\pm 1.5V$, $\pm 2.5V$ & $\pm 5V$ supply operation
- 0.1 μW power dissipation
- 1pC charge injection
- Rail to rail signal range
- Low on-resistance
- pA leakage current
- 4201 break-before-make switching
- 4202M make-before-break switching
- Built-in dual supply level translator

BENEFITS

- Fast effective signal throughput
- Low switching transients
- Low signal loss
- Essentially no DC power consumption
- Full analog signal range over power supply rail
- Flexible power supply range for battery operated systems

APPLICATIONS

- Low level signal conditioning circuits
- Portable battery operated instruments
- Computer peripherals
- PCMCIA
- Fast sample and hold
- Analog signal multiplexer
- Programmable gain amplifiers
- Switched capacitor circuits
- Micropower based systems
- Video/audio switches
- Feedback control systems

PIN CONFIGURATION / BLOCK DIAGRAM

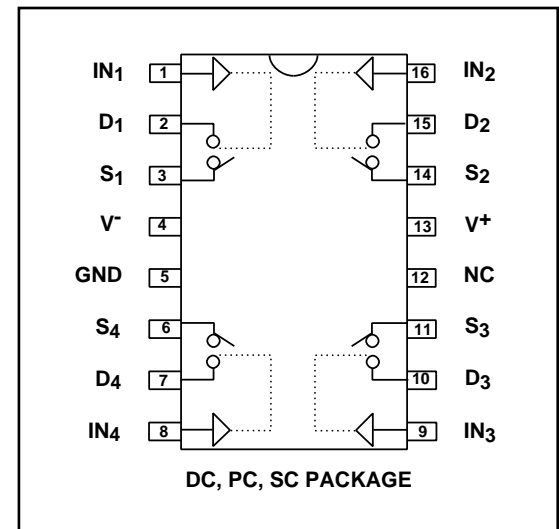

ABSOLUTE MAXIMUM RATINGS

Supply voltage, V+ referenced to V-	_____	-0.3V to +13.2V	
GND	_____	-0.3V to +13.2V	
Terminal voltage range (any terminal) Note 1	_____	(V- -0.3)V to (V+ +0.3)V	
Power dissipation	_____	600 mW	
Operating temperature range	PC, SC package	_____	0°C to +70°C
	DC package	_____	-55°C to +125°C
Storage temperature range	_____	-65°C to +150°C	
Lead temperature, 10 seconds	_____	+260°C	
DC current (any terminal)	_____	10mA	

POWER SUPPLY RANGE

Parameter	Symbol	4201/4202M (PC,SC)			4201/4202M (DC)			Unit	
		Min	Typ	Max	Min	Typ	Max		
Supply Voltage	V _{SUPPLY}	±1.5		±6.0	±1.5		±6.0	V	Dual Supply Single Supply
		3.0		12.0	3.0		12.0		

DC ELECTRICAL CHARACTERISTICS

T_A = 25°C V+ = +5.0V, V- = -5.0V GND = 0.0V unless otherwise specified

Parameter	Symbol	4201/4202M (PC,SC)			4201/4202M (DC)			Max	Unit	Test Conditions
		Min	Typ	Max	Max	Min	Typ			
Analog Signal Range	V _A	-5.0		5.0	-5.0		5.0	V		
On - Resistance	R _{ON}		90 120	135 180		90 140	135 210	Ω	V _A = 0V I _A = 1mA 0°C to +70°C -55°C to +125°C	
Change of On-Resistance from -V _S to +V _S	ΔR _{ON}		16			16		%		
Change of On-Resistance with Temperature	ΔR _{ON} /ΔT		0.43			0.43		%/°C		
R _{ON} Match Between Switches			2			2		%		
Source Off Leakage Current	I _{S(OFF)}		50	100 500		50	100 4000	pA pA pA	V _S = +/-4.0V, V _D = -/+4.0V 0°C to +70°C -55°C to +125°C	
Drain Off Leakage Current	I _{D(OFF)}		50	100 500		50	100 4000	pA pA pA	V _D = +/-4.0V, V _S = -/+4.0V 0°C to +70°C -55°C to +125°C	
Channel On Leakage Current	I _{D(ON)}		50	100 500		50	100 4000	pA pA pA	0°C to +70°C -55°C to +125°C	
Input High Voltage	V _{IH}	4.0			4.0				Logic "1"	
Input Low Voltage	V _{IL}			0.8			0.8	V	Logic "0"	
Input High or Input Low Current	I _{IH} I _{IL}			10			10	nA	±1.5 ≤ V _{SUPPLY} ≤ ±5.0V	
Supply Current	I _{SUPPLY}		0.01	1		0.01	1	μA		

AC ELECTRICAL CHARACTERISTICS

$T_A = 25^\circ\text{C}$ $V_+ = +5.0\text{V}$, $V_- = -5.0\text{V}$, $\text{GND} = 0.0\text{V}$ unless otherwise specified

Parameter	Symbol	4201/4202M (PC)			4201/4202M (DC)			4201/4202M (SC)			Unit	Test Conditions
		Min	Typ	Max	Min	Typ	Max	Min	Typ	Max		
Turn On Delay time	t_{ON}		150 60	240 110		150 60	240 110		150 60	240 110	ns ns	4201 (Note 2) 4202M
Turn Off Delay time	t_{OFF}		60 100	130 180		60 100	130 180		60 100	130 180	ns ns	4201 (Note 2) 4202M
Break-Before-Make Delay Time	t_{BD}	20	90		20	90		20	90		ns	4201 (Note 3)
Make-Before-Break Delay Time	t_{MD}	15	40		15	40		15	40		ns	4202M (Note 3)
Charge Injection	Q_{INJ}		2 1	5 2.5		2 1	5 2.5		1 0.7	2.5 2.0	pC pC	4201 (Note 3) (Note 4) 4202M
Off Isolation			75			75			75		dB	At $f = 100\text{KHz}$, (Note 5)
Crosstalk			90			90			90		dB	At $f = 100\text{KHz}$, (Note 6)
Total Harmonic Distortion	T_{HD}		0.05 0.01			0.05 0.01			0.05 0.01		%	$R_L = 10\text{K}$ $R_L = 100\text{K}$
Source/Drain Off Capacitance	$C_{S(OFF)}$ $C_{D(OFF)}$		3.0			3.0			3.0		pF	
Channel On Capacitance	$C_{DS(ON)}$		5.7			5.7			5.7		pF	
Pin to Pin Capacitance	C_{PP}		0.5			0.6			0.25		pF	

DC ELECTRICAL CHARACTERISTICS

$T_A = 25^\circ\text{C}$ $V_+ = +5.0\text{V}$, $V_- = \text{GND} = 0.0\text{V}$ unless otherwise specified

Parameter	Symbol	ALD4201/4202M (PC,SC)			ALD4201/4202M (DC)			Unit	Test Conditions
		Min	Typ	Max	Min	Typ	Max		
Analog Signal Range	V_A	0.0		+5.0	0.0		+5.0	V	
On - Resistance	R_{ON}		195 240	280 350		195 270	280 390	Ω	$V_A = +2.5\text{V}$ $I_A = 1\text{mA}$ 0°C to $+70^\circ\text{C}$ -55°C to $+125^\circ\text{C}$
Change of On-Resistance from - V_S to $+V_S$	ΔR_{ON}		20			20		%	
Change of On-Resistance with Temperature	$\Delta R_{ON}/\Delta T$		0.43			0.43		%/ $^\circ\text{C}$	
R_{ON} Match Between Switches			2			2		%	
Input High Voltage	V_{IH}	4.0			4.0			V	
Input Low Voltage	V_{IL}			0.8			0.8	V	

Notes:

1. Voltage on any terminal must be less than $(V_+) + 0.3\text{V}$ and greater than $(V_-) - 0.3\text{V}$, at all times including before power is applied and $V_+ = V_- = 0.0\text{V}$. Vsupply power supply needs to be sequenced on first on power turn-on and sequenced off last during power turn-off.
2. See Switching Time Test Circuit.
3. Guaranteed by design.
4. See Charge Injection Test Circuit.
5. See Off Isolation Test Circuit.
6. See Crosstalk Test Circuit.

DC ELECTRICAL CHARACTERISTICS

$T_A = 25^\circ\text{C}$ $V_+ = +3.0\text{V}$, $V_- = \text{GND} = 0.0\text{V}$ unless otherwise specified

Parameter	Symbol	4201/4202M (PC,SC)			4201/4202M (DC)			Unit	Test Conditions
		Min	Typ	Max	Min	Typ	Max		
Analog Signal Range	V_A	0.0		3.0	0.0		3.0	V	
On - Resistance	R_{ON}	620	500 880	700		500 680	700 1000	Ω	$V_A = 1.5\text{V}$ $I_A = 1\text{mA}$ 0°C to $+70^\circ\text{C}$ -55°C to $+125^\circ\text{C}$
Change of On-Resistance from $-V_S$ to $+V_S$	ΔR_{ON}		43			43		%	
Change of On-Resistance with Temperature	$\Delta R_{ON}/\Delta T$		0.27			0.27		%/ $^\circ\text{C}$	
R_{ON} Match Between Switches			2			2		%	
Input High Voltage	V_{IH}	2.4			2.4			V	
Input Low Voltage	V_{IL}			0.8			0.8	V	

TYPICAL PERFORMANCE CHARACTERISTICS

POWER DISSIPATION AS A FUNCTION OF FREQUENCY

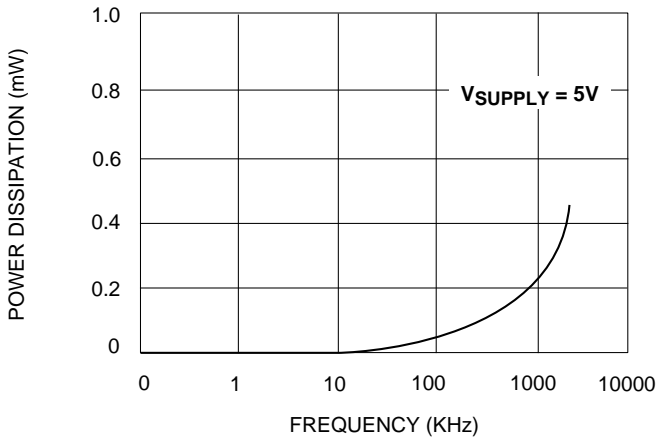

ON RESISTANCE AS A FUNCTION OF SIGNAL VOLTAGE

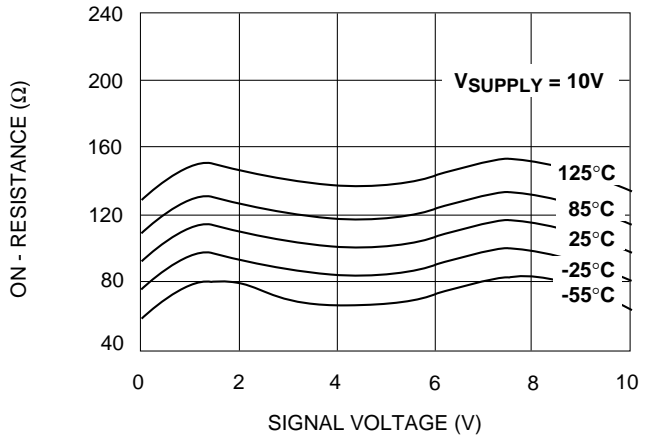

ON RESISTANCE AS A FUNCTION OF SIGNAL VOLTAGE

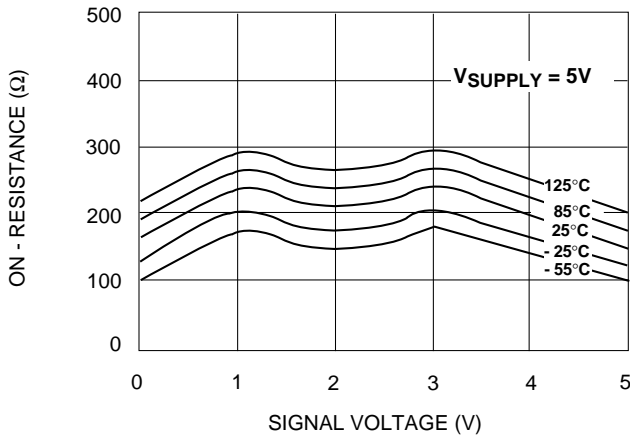

ON RESISTANCE AS A FUNCTION OF SIGNAL VOLTAGE

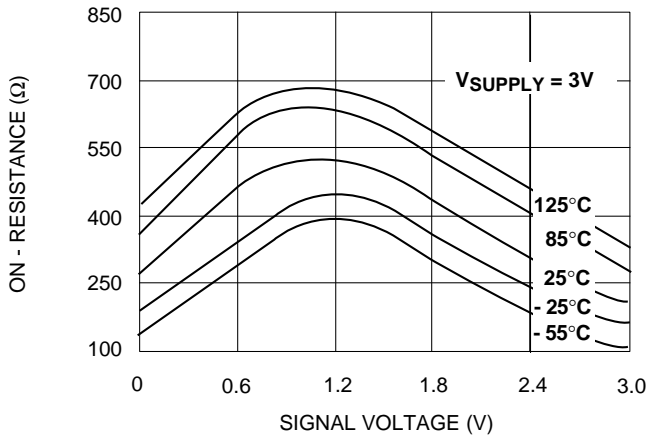

TYPICAL PERFORMANCE CHARACTERISTICS

SUPPLY CURRENT AS A FUNCTION OF INPUT VOLTAGE

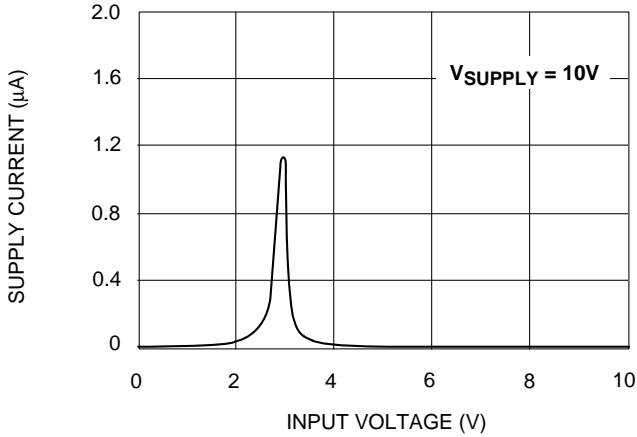

SUPPLY CURRENT AS A FUNCTION OF INPUT VOLTAGE

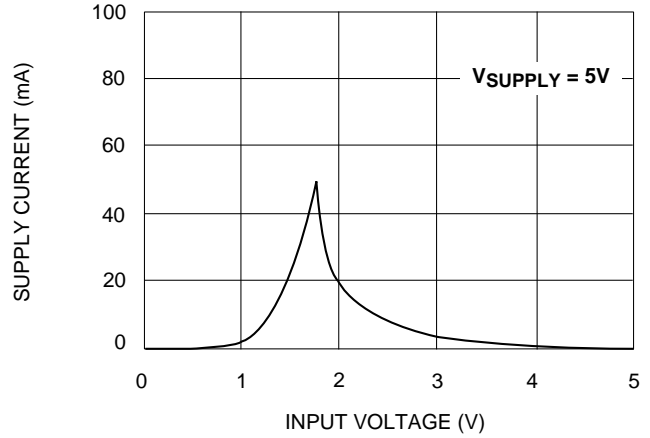

SUPPLY CURRENT AS A FUNCTION OF INPUT VOLTAGE

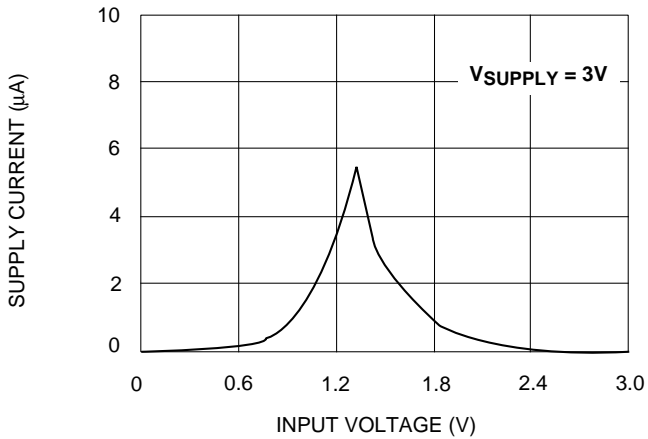

TOTAL HARMONIC DISTORTION AS A FUNCTION OF FREQUENCY

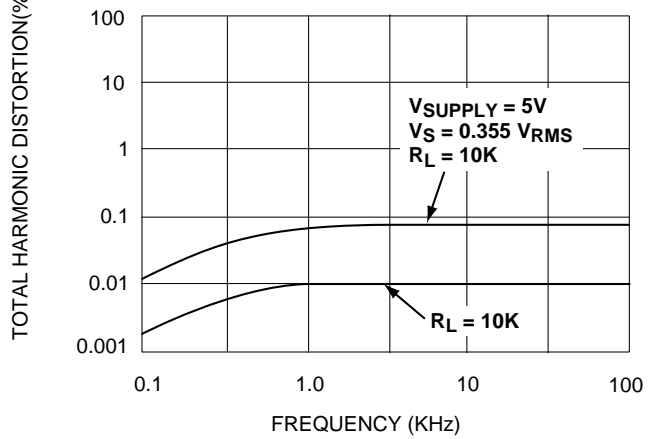

SWITCH DELAY TIME AS A FUNCTION OF SUPPLY VOLTAGE

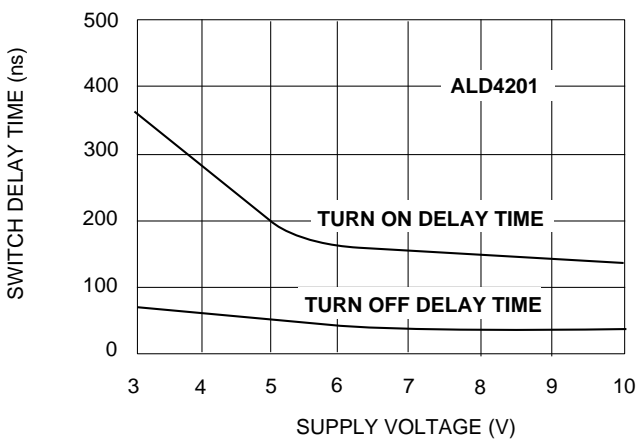

SWITCH DELAY TIME AS A FUNCTION OF SUPPLY VOLTAGE

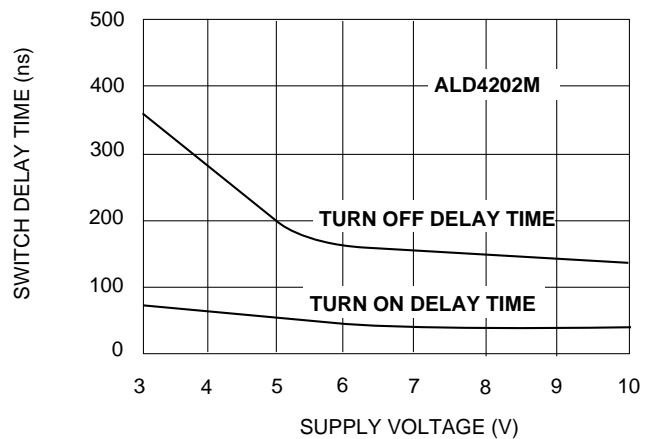

TEST CIRCUITS

SWITCHING TIME TEST CIRCUIT

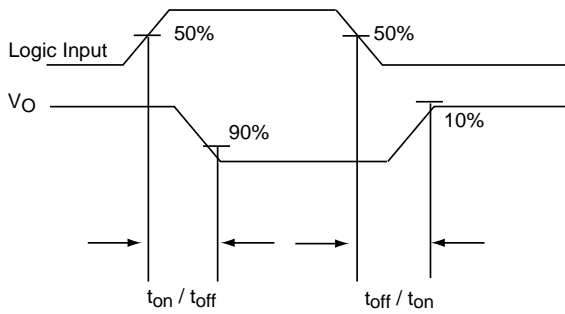
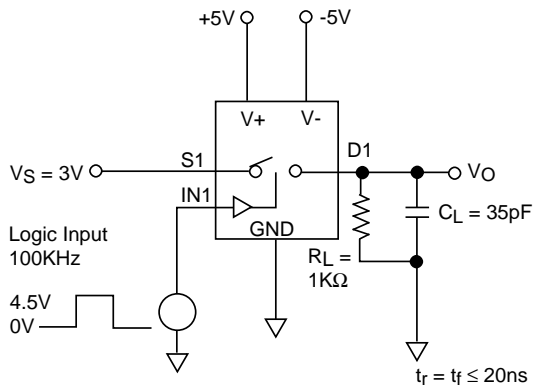

CHARGE INJECTION TEST CIRCUIT

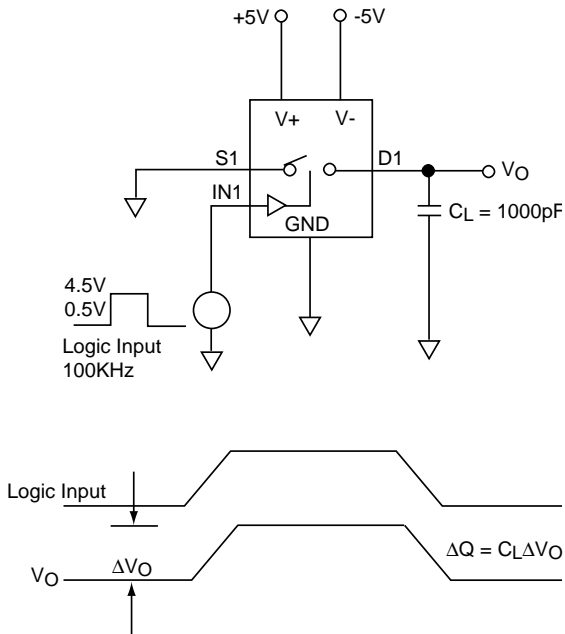

CROSSTALK TEST CIRCUIT

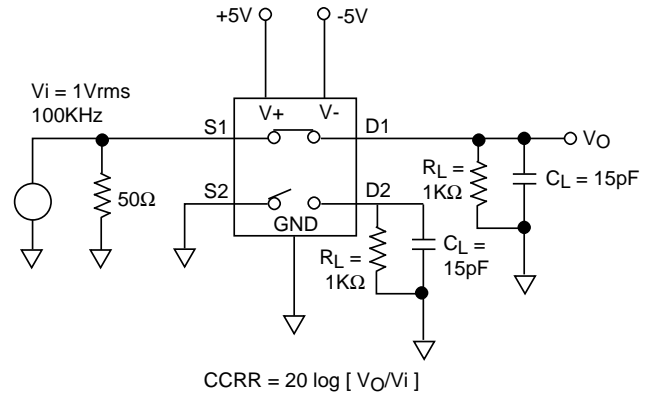

TOTAL HARMONIC DISTORTION TEST CIRCUIT

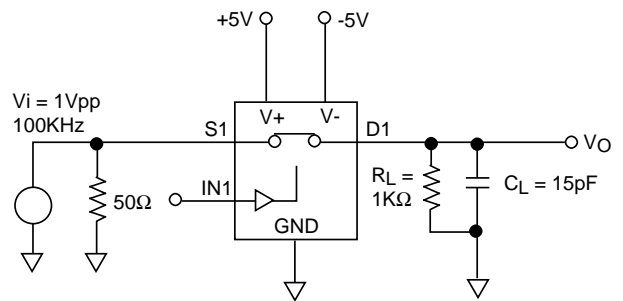

OFF ISOLATION TEST CIRCUIT

