

NPN SILICON RF POWER TRANSISTOR

DESCRIPTION:

The **ASI AVD075F** is Designed for Class C, DME/TACAN Applicatons up to 1150 MHz.

FEATURES:

- Internal Input Matching Network
- $P_G = 7.5$ dB at 75 W/1150 MHz
- **Omnigold™** Metalization System

MAXIMUM RATINGS

I_C	6.5 A PEAK
V_{CB}	55 V
P_{DISS}	250 W PEAK
T_J	-65 °C to +200 °C
T_{STG}	-65 °C to +150 °C
θ_{JC}	0.7 °C/W

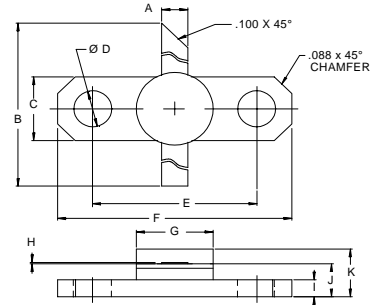
PACKAGE STYLE .250 2L FLG (B)

DIM	MINIMUM inches / mm	MAXIMUM inches / mm
A	.095 / 2.41	.105 / 2.67
B	1.050 / 26.67	
C	.245 / 6.22	.255 / 6.48
D	.120 / 3.05	.140 / 3.56
E	.552 / 14.02	.572 / 14.53
F	.790 / 20.07	.810 / 20.57
G		.285 / 7.24
H	.003 / 0.08	.007 / 0.18
I	.052 / 1.32	.072 / 1.83
J	.120 / 3.05	.130 / 3.30
K		.210 / 5.33

ORDER CODE: ASI10560
CHARACTERISTICS $T_C = 25$ °C

SYMBOL	TEST CONDITIONS	MINIMUM	TYPICAL	MAXIMUM	UNITS
BV_{CBO}	$I_C = 10$ mA	65			V
BV_{CER}	$I_C = 10$ mA $R_{BE} = 10$ Ω	65			V
BV_{EBO}	$I_E = 1.0$ mA	3.5			V
I_{CES}	$V_{CE} = 50$ V			6.25	mA
h_{FE}	$V_{CE} = 5.0$ V $I_C = 500$ mA	15		120	---
P_G	$V_{CC} = 50$ V $P_{OUT} = 75$ W $f = 1025 - 1150$ MHz	7.5			dB
η_c		35			%