

Boca Semiconductor Corp.

BSC

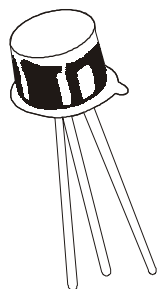

APPLICATIONS

2N2369/A are NPN Silicon High Speed Saturated Switching, Transistors With Low Power & High Speed Switching Applications.

ABSOLUTE MAXIMUM RATINGS

DESCRIPTION	SYMBOL	VALUE	UNIT
Collector -Emitter Voltage	VCEO	15	V
Collector -Emitter Voltage	VCES	40	V
Collector -Base Voltage	VCBO	40	V
Emitter -Base Voltage	VEBO	4.5	V
Collector Current Continuous	IC	200	mA
Collector Current Peak(10us pulse)	IC(peak)	500	mA
Power Dissipation@ Ta=25 degC	PD	360	mW
Derate Above 25 deg C		2.06	mW/deg C
@Tc=25 deg C	PD	1.2	W
@Tc=100 deg C	PD	0.68	W
Derate Above100 deg C		6.85	mW/deg C
Operating And Storage Junction Temperature Range	Tj, Tstg	-65 to +200	deg C

ELECTRICAL CHARACTERISTICS (Ta=25 deg C Unless Otherwise Specified)

DESCRIPTION	SYMBOL	TEST CONDITION	2N2369	2N2369A	UNIT
Collector -Emitter Voltage	VCEO*(sus)	IC=10mA, IB=0	>15	>15	V
Collector -Emitter Voltage	VCES	IC=10uA, VBE=0	>40	>40	V
Collector -Base Voltage	VCBO	IC=10uA, IE=0	>40	>40	V
Emitter -Base Voltage	VEBO	IE=10uA, IC=0	>4.5	>4.5	V
Collector-Cut off Current	ICBO	VCB=20V, IE=0	<400	-	nA
		VCB=20V, IE=0, Ta=150 deg C	<30	-	uA
		ICES	VCE=20V, VBE=0	-	<400
Base Current	IB	VCE=20V, VBE=0	-	<400	nA
Collector Emitter Saturation Voltage	VCE(Sat)*	IC=10mA, IB=1mA	<0.25	<0.20	V
		IC=30mA, IB=3mA	-	<0.25	V
		IC=100mA, IB=10mA	-	<0.50	V
		IC=10mA, IB=1mA, Ta= +125 deg C	-	<0.30	V
Base Emitter Saturation Voltage	VBE(Sat) *	IC=10mA, IB=1mA	0.7-0.85	0.7-0.85	V
		IC=30mA, IB=3mA	-	<1.15	V
		IC=100mA, IB=10mA	-	<1.60	V
		IC=10mA, IB=1mA, Ta= +125 deg C	-	>0.59	V
		IC=10mA, IB=1mA, Ta= -55 deg C	-	<1.02	V
DC Current	hFE*	IC=10mA, VCE=1V	40-120	40-120	
		IC=10mA, VCE=1V, Ta= -55 deg C	>20	-	
		IC=10mA, VCE=0.35V, Ta= -55 deg C	-	>20	

ELECTRICAL CHARACTERISTICS (Ta=25 deg C Unless Otherwise Specified)

2N2369/2369A

DESCRIPTION	SYMBOL	TEST CONDITION	2N2369	2N2369A	UNIT
DC Current	hFE*	IC=10mA, VCE=0.35V	-	40-120	
		IC=30mA, VCE=0.4V	-	>30	
		IC=100mA, VCE=1V	-	>20	
		IC=100mA, VCE=2V	>20	-	
Small Signal Characteristics					
Transition Frequency	ft	VCE=10V, IC=10mA, f=100MHz	>500	>500	MHZ
Output Capacitance	Cobo	VCB=5V, IE=0, f=140kHz	<4.0	<4.0	pF
Turn on Time	ton	IC=10mA, IB1=3mA, IB= -1.5mA, VCC=3V	<12	<12	ns
Turn off Time	toff	IC=10mA, IB1=3mA, IB2= -1.5mA, VCC=3V	-	<15	ns
Storage Time	ts	IC=100mA, IB1=IB=10mA, VCC=10V	<13	<13	ns

*Pulse Test : Pulse Width =300us, Duty Cycle=2%

TO-18 Metal Can Package

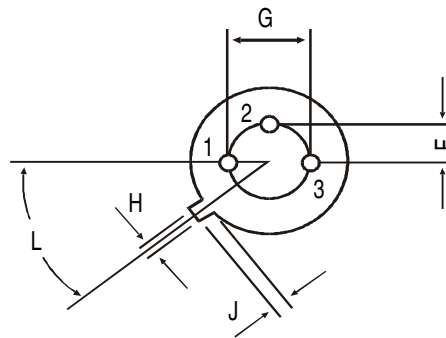
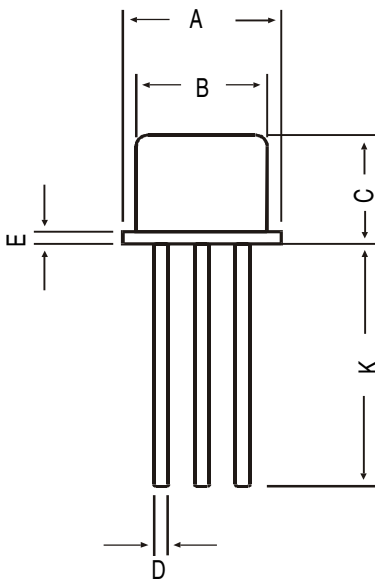

All diminsions in mm.

DIM	MIN	MAX
A	5.24	5.84
B	4.52	4.97
C	4.31	5.33
D	0.40	0.53
E	—	0.76
F	—	1.27
G	—	2.97
H	0.91	1.17
J	0.71	1.21
K	12.70	—
L	45 DEG	

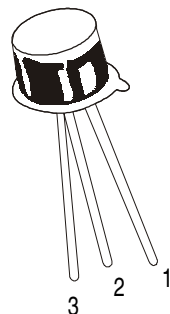

PIN CONFIGURATION

1. EMITTER
2. BASE
3. COLLECTOR