

MOS FIELD EFFECT TRANSISTOR  
**2SK2410**

SWITCHING  
 N-CHANNEL POWER MOS FET  
 INDUSTRIAL USE

**DESCRIPTION**

The 2SK2410 is N-Channel MOS Field Effect Transistor designed for high speed switching applications.

**FEATURES**

- Low On-Resistance  
 $R_{DS(on)1} = 40 \text{ m}\Omega \text{ MAX. (@ } V_{GS} = 10 \text{ V, } I_D = 15 \text{ A)}$   
 $R_{DS(on)2} = 60 \text{ m}\Omega \text{ MAX. (@ } V_{GS} = 4 \text{ V, } I_D = 15 \text{ A)}$
- Low  $C_{iss}$   $C_{iss} = 1500 \text{ pF TYP.}$
- High Avalanche Capability Ratings
- Built-in G-S Gate Protection Diodes

**QUALITY GRADE**

Standard

Please refer to "Quality grade on NEC Semiconductor Devices" (Document number IEI-1209) published by NEC Corporation to know the specification of quality grade on the devices and its recommended applications.

**ABSOLUTE MAXIMUM RATINGS (TA = 25 °C)**

|   |                |             |                  |
|---|----------------|-------------|------------------|
| Drain to Source Voltage                                       | $V_{DSS}$      | 60          | V                |
| Gate to Source Voltage  | $V_{GSS}$      | $\pm 20$    | V                |
| Drain Current (DC)  | $I_{D(DC)}$    | $\pm 30$    | A                |
| Drain Current (pulse)*  | $I_{D(pulse)}$ | $\pm 120$   | A                |
| Total Power Dissipation ( $T_c = 25 \text{ }^\circ\text{C}$ ) | $P_{T1}$       | 35          | W                |
| Total Power Dissipation ( $T_A = 25 \text{ }^\circ\text{C}$ ) | $P_{T2}$       | 2.0         | W                |
| Channel Temperature   | $T_{ch}$       | 150         | $^\circ\text{C}$ |
| Storage Temperature   | $T_{stg}$      | -55 to +150 | $^\circ\text{C}$ |
| Single Avalanche Current**                                    | $I_{AS}$       | 30          | A                |
| Single Avalanche Energy**                                     | $E_{AS}$       | 90          | mJ               |

\*  $PW \leq 10 \text{ } \mu\text{s}$ , Duty Cycle  $\leq 1 \%$

\*\* Starting  $T_{ch} = 25 \text{ }^\circ\text{C}$ ,  $R_G = 25 \text{ } \Omega$ ,  $V_{GS} = 20 \text{ V} \rightarrow 0$

**PACKAGE DIMENSIONS**

(in millimeters)

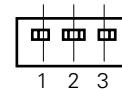
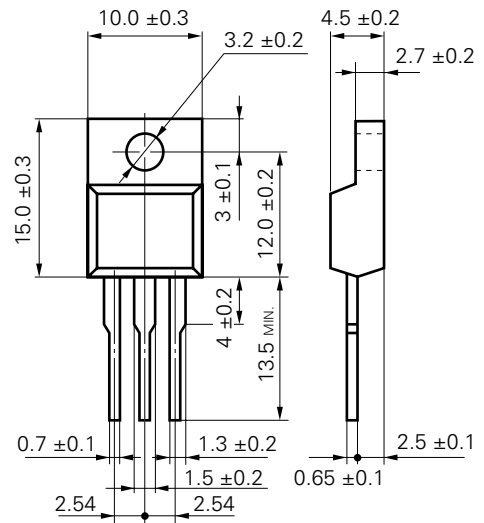

1. Gate
2. Drain
3. Source

**MP-45F (ISOLATED TO-220)**

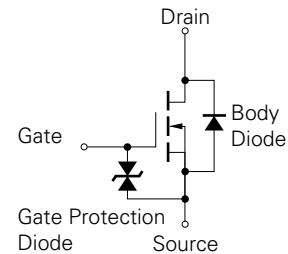

The information in this document is subject to change without notice.

**ELECTRICAL CHARACTERISTICS (T<sub>A</sub> = 25 °C)**

| CHARACTERISTIC                 | SYMBOL               | MIN. | TYP. | MAX. | UNIT | TEST CONDITIONS                               |
|--------------------------------|----------------------|------|------|------|------|---|
| Drain to Source On-Resistance  | R <sub>DS(on)1</sub> |      | 31   | 40   | mΩ   | V <sub>GS</sub> = 10 V, I <sub>D</sub> = 15 A |
| Drain to Source On-Resistance  | R <sub>DS(on)2</sub> |      | 40   | 60   | mΩ   | V <sub>GS</sub> = 4 V, I <sub>D</sub> = 15 A  |
| Gate to Source Cutoff Voltage  | V <sub>GS(off)</sub> | 1.0  | 1.5  | 2.0  | V    | V <sub>DS</sub> = 10 V, I <sub>D</sub> = 1 mA |
| Forward Transfer Admittance    | y <sub>fs</sub>      | 15   | 27   |      | S    | V <sub>DS</sub> = 10 V, I <sub>D</sub> = 15 A |
| Drain Leakage Current          | I <sub>bss</sub>     |      |      | 10   | μA   | V <sub>DS</sub> = 60 V, V <sub>GS</sub> = 0   |
| Gate to Source Leakage Current | I <sub>gss</sub>     |      |      | ±10  | μA   | V <sub>GS</sub> = ±20 V, V <sub>DS</sub> = 0  |
| Input Capacitance              | C <sub>iss</sub>     |      | 1500 |      | pF   | V <sub>DS</sub> = 10 V                        |
| Output Capacitance             | C <sub>oss</sub>     |      | 720  |      | pF   | V <sub>GS</sub> = 0                           |
| Reverse Transfer Capacitance   | C <sub>rss</sub>     |      | 190  |      | pF   | f = 1 MHz                                     |
| Turn-On Delay Time             | t <sub>d(on)</sub>   |      | 22   |      | ns   | I <sub>D</sub> = 15 A                         |
| Rise Time                      | t <sub>r</sub>       |      | 260  |      | ns   | V <sub>GS(on)</sub> = 10 V                    |
| Turn-Off Delay Time            | t <sub>d(off)</sub>  |      | 130  |      | ns   | V <sub>DD</sub> = 30 V                        |
| Fall Time                      | t <sub>f</sub>       |      | 150  |      | ns   | R <sub>G</sub> = 10 Ω                         |
| Total Gate Charge              | Q <sub>G</sub>       |      | 50   |      | nC   | I <sub>D</sub> = 30 A                         |
| Gate to Source Charge          | Q <sub>GS</sub>      |      | 5.0  |      | nC   | V <sub>DD</sub> = 48 V                        |
| Gate to Drain Charge           | Q <sub>GD</sub>      |      | 15   |      | nC   | V <sub>GS</sub> = 10 V                        |
| Body Diode Forward Voltage     | V <sub>F(S-D)</sub>  |      | 1.1  |      | V    | I <sub>F</sub> = 30 A, V <sub>GS</sub> = 0    |
| Reverse Recovery Time          | t <sub>rr</sub>      |      | 110  |      | ns   | I <sub>F</sub> = 30 A, V <sub>GS</sub> = 0    |
| Reverse Recovery Charge        | Q <sub>rr</sub>      |      | 320  |      | nC   | di/dt = 100 A/μs                              |

**Test Circuit 1 Avalanche Capability**

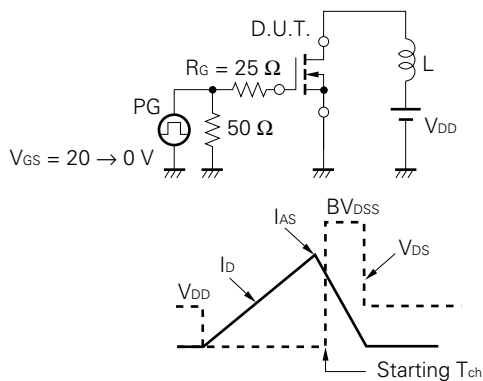

**Test Circuit 2 Switching Time**

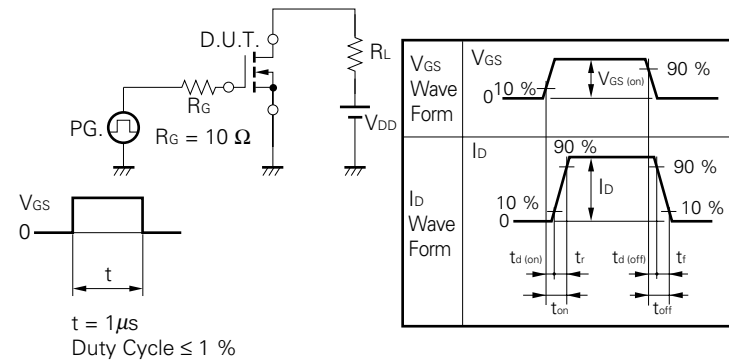

**Test Circuit 3 Gate Charge**

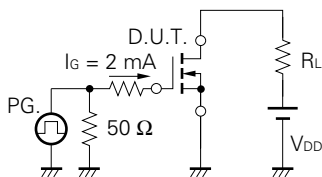

The application circuits and their parameters are for references only and are not intended for use in actual design-in's.

TYPICAL CHARACTERISTICS (T<sub>A</sub> = 25 °C)

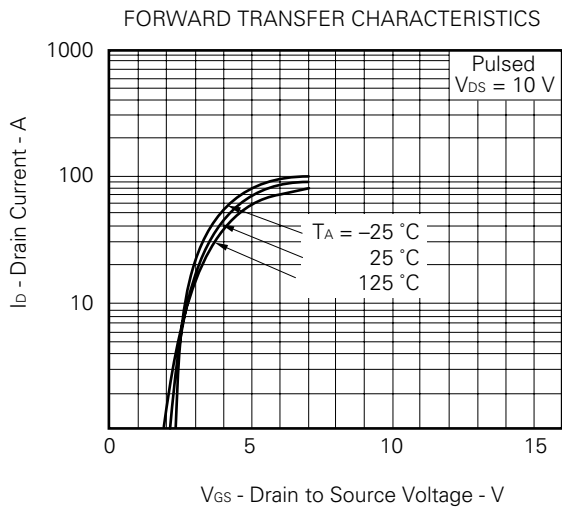
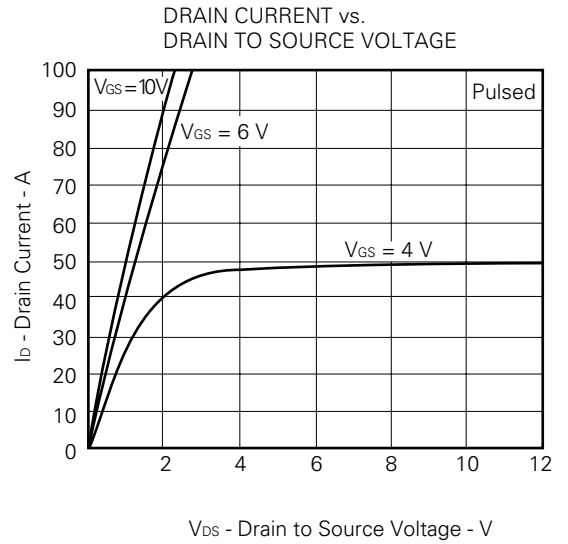
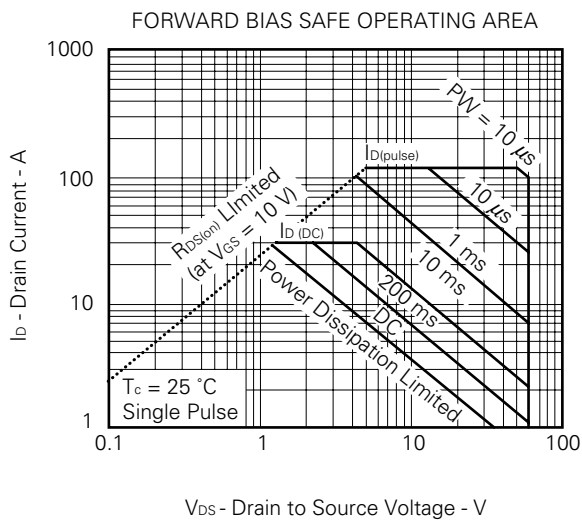
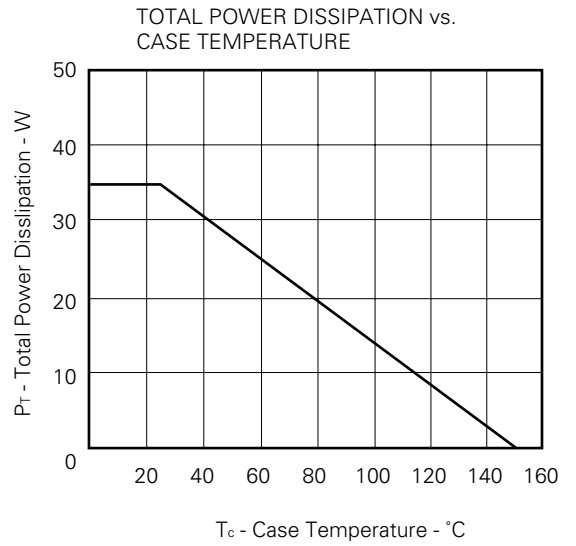
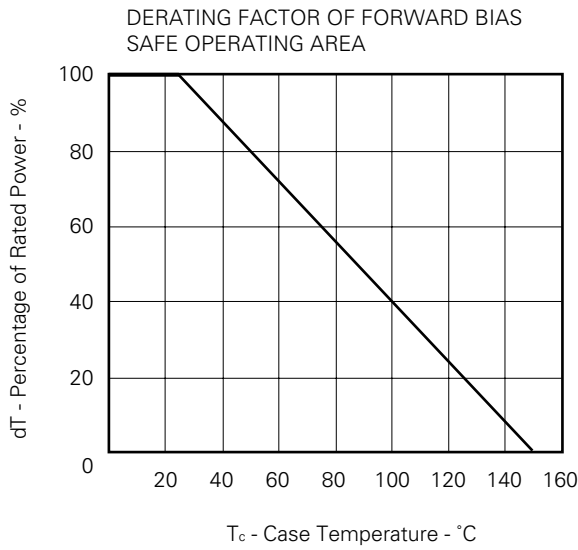

TRANSIENT THERMAL RESISTANCE vs. PULSE WIDTH

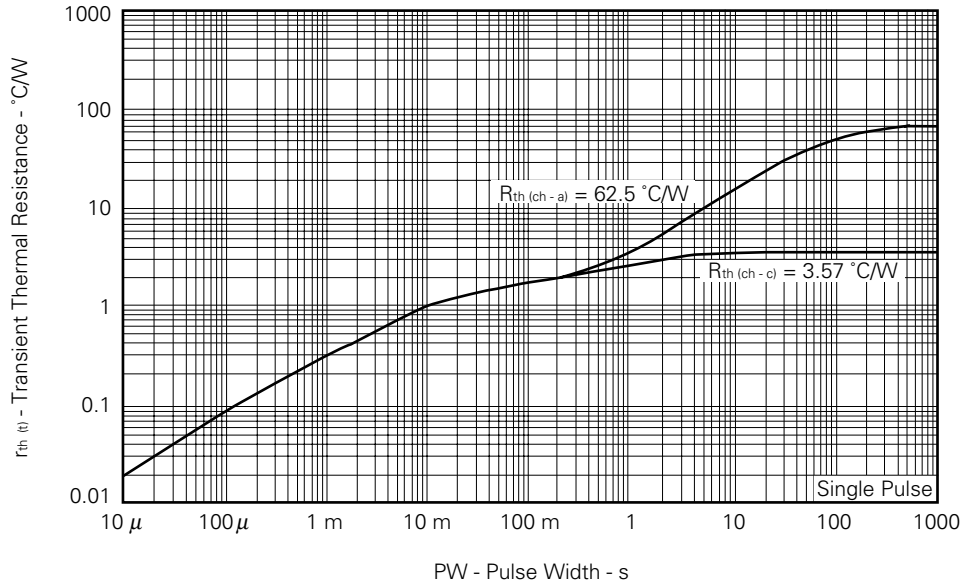

FORWARD TRANSFER ADMITTANCE vs. DRAIN CURRENT

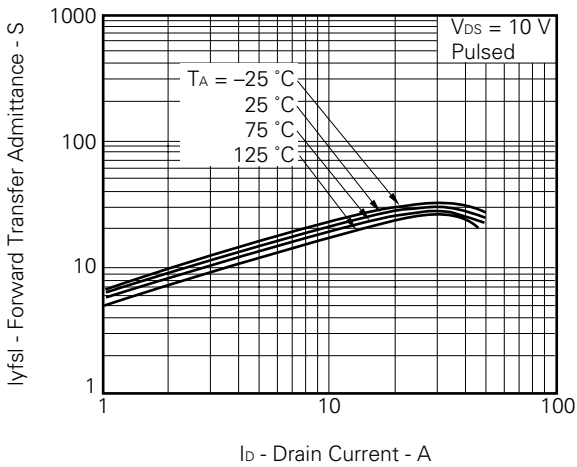

DRAIN TO SOURCE ON-STATE RESISTANCE vs. GATE TO SOURCE VOLTAGE

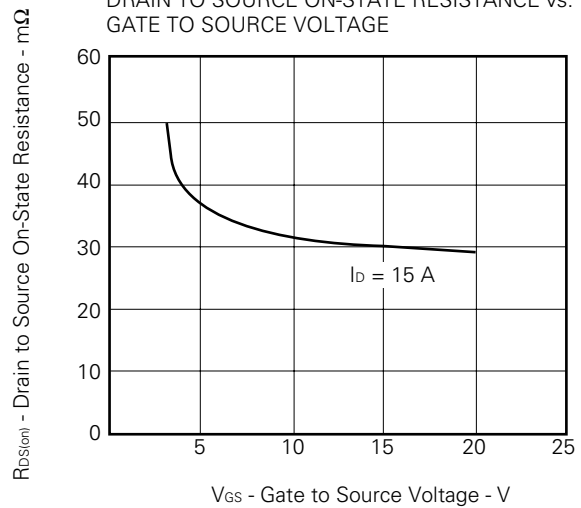

DRAIN TO SOURCE ON-STATE RESISTANCE vs. DRAIN CURRENT

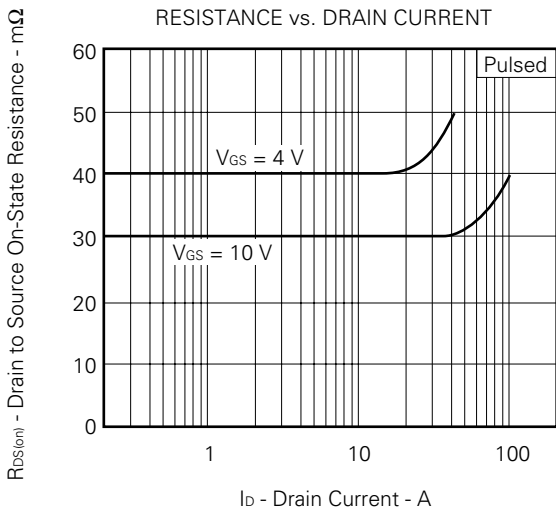

GATE TO SOURCE CUTOFF VOLTAGE vs. CHANNEL TEMPERATURE

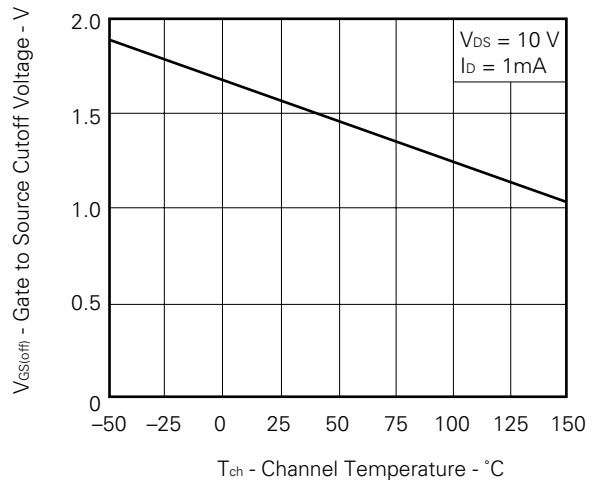

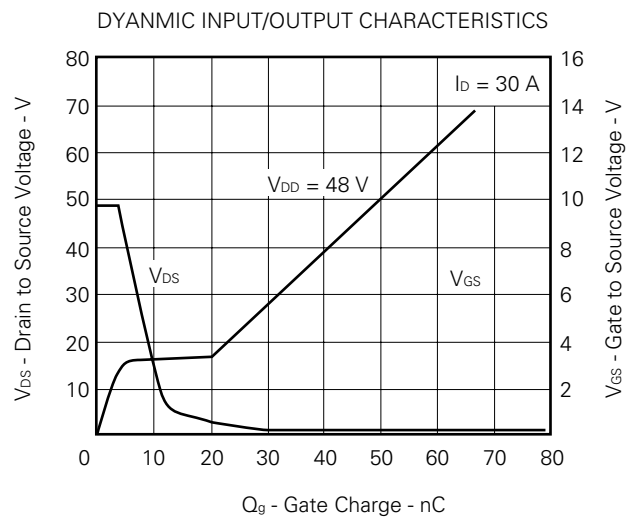
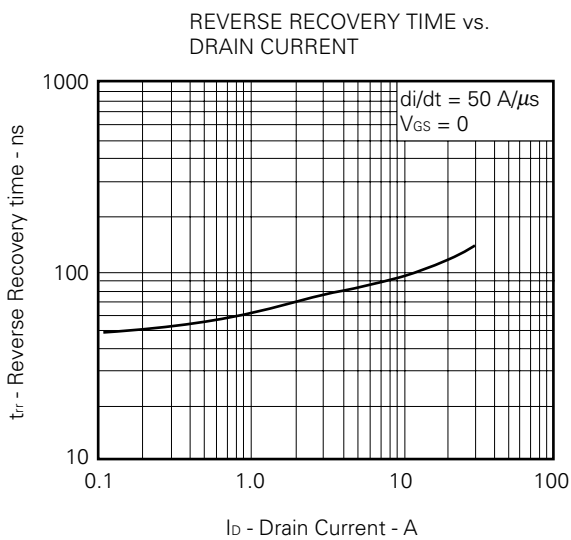
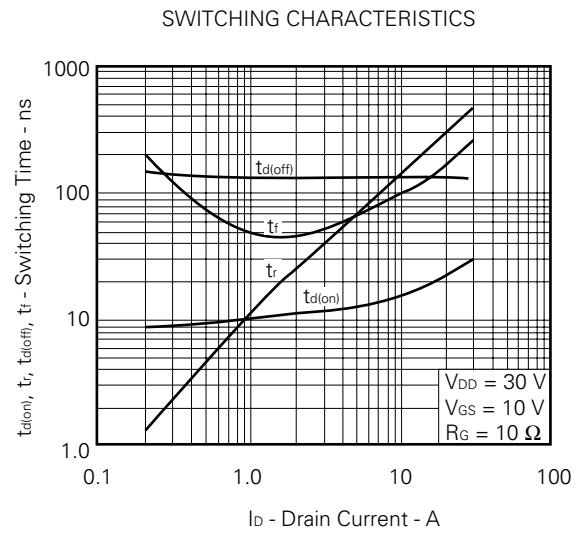
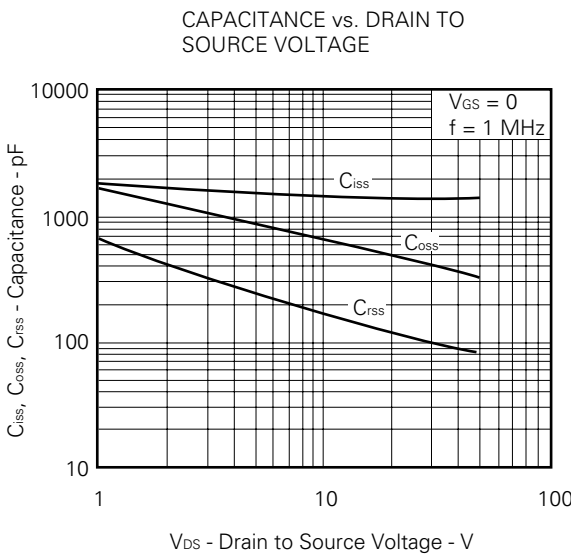
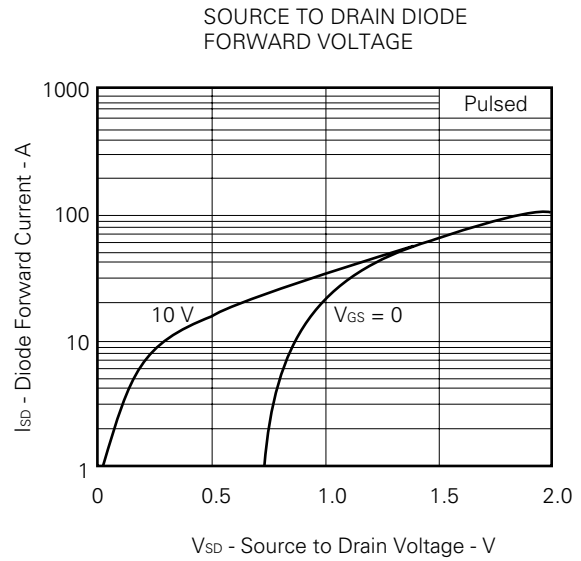
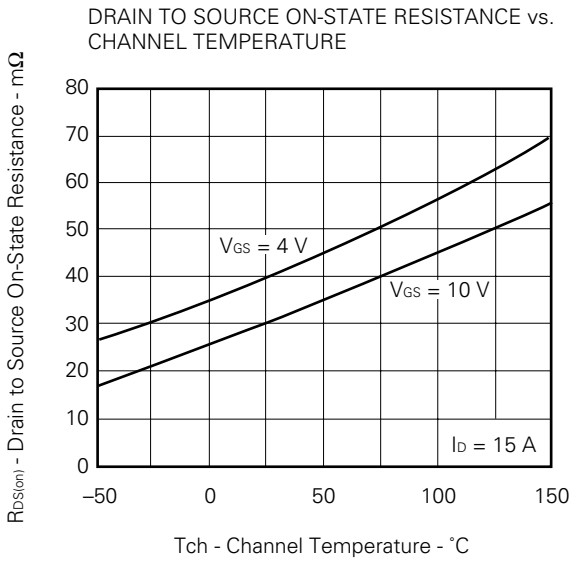

SINGLE AVALANCHE ENERGY vs. INDUCTIVE LOAD

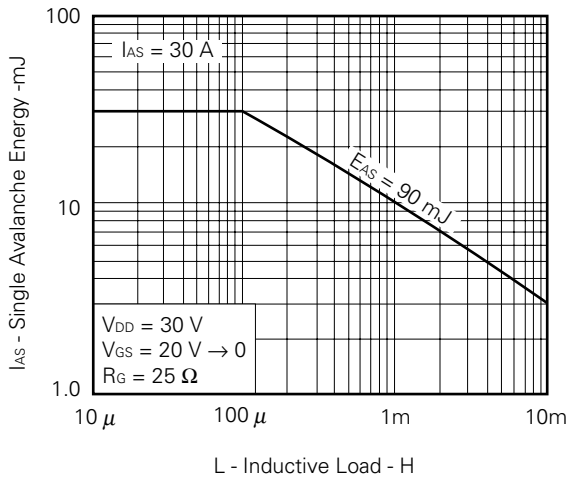

SINGLE AVALANCHE ENERGY DERATING FACTOR

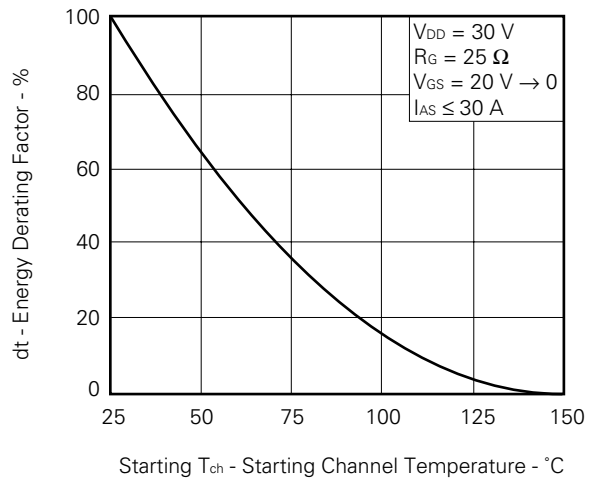

**REFERENCE**

| Document Name  | Document No. |
|--|--------------|
| NEC semiconductor device reliability/quality control system.   | TEI-1202     |
| Quality grade on NEC semiconductor devices.                    | IEI-1209     |
| Semiconductor device mounting technology manual.               | IEI-1207     |
| Semiconductor device package manual.                           | IEI-1213     |
| Guide to quality assurance for semiconductor devices.          | MEI-1202     |
| Semiconductor selection guide.                                 | MF-1134      |
| Power MOS FET features and application switching power supply. | TEA-1034     |
| Application circuits using Power MOS FET.                      | TEA-1035     |
| Safe operating area of Power MOS FET.                          | TEA-1037     |

The diode connected between the gate and source of the transistor serves as a protector against ESD. When this device is actually used, an additional protection circuit is externally required if a voltage exceeding the rated voltage may be applied to this device.

## [MEMO]

No part of this document may be copied or reproduced in any form or by any means without the prior written consent of NEC Corporation. NEC Corporation assumes no responsibility for any errors which may appear in this document.

NEC Corporation does not assume any liability for infringement of patents, copyrights or other intellectual property rights of third parties by or arising from use of a device described herein or any other liability arising from use of such device. No license, either express, implied or otherwise, is granted under any patents, copyrights or other intellectual property rights of NEC Corporation or others.

The devices listed in this document are not suitable for use in aerospace equipment, submarine cables, nuclear reactor control systems and life support systems. If customers intend to use NEC devices for above applications or they intend to use "Standard" quality grade NEC devices for applications not intended by NEC, please contact our sales people in advance.

Application examples recommended by NEC Corporation

Standard: Computer, Office equipment, Communication equipment, Test and Measurement equipment, Machine tools, Industrial robots, Audio and Visual equipment, Other consumer products, etc.

Special: Automotive and Transportation equipment, Traffic control systems, Antidisaster systems, Anticrime systems, etc.