



NPN MEDIUM POWER MICROWAVE TRANSISTOR

NE568 SERIES

FEATURES

- HIGH f_s : 4.2 GHz
- HIGH MAXIMUM AVAILABLE GAIN: 14 dB at 2 GHz
- HIGH OSCILLATOR POWER OUTPUT:
200 mW at 6 GHz
- HIGH RELIABILITY
- ADVANCED SET TECHNOLOGY

DESCRIPTION AND APPLICATIONS

The NE568 series of NPN silicon medium power transistors is designed for medium power S and C band linear amplifiers and oscillators up to 6 GHz. The series takes advantage of NEC's advanced Stepped Electrode Transistor (SET) technology. SET devices provide excellent performance with unusually high reliability because they normally operate at low junction temperatures. The NE568 is available in a variety of package styles to suit your design needs. The transistor is also available in chip form (NE56800).

OUTLINE DIMENSIONS (Units in mm)

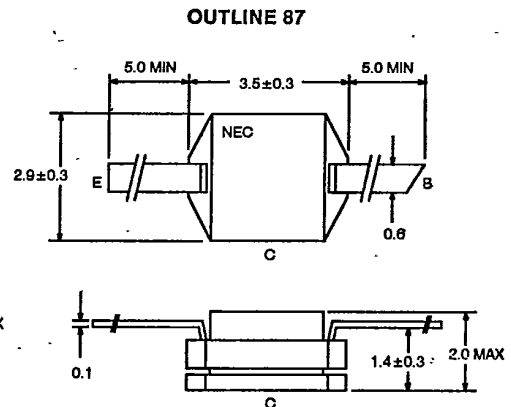
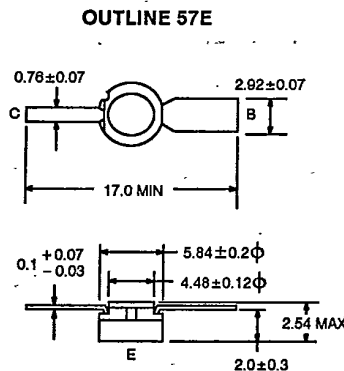
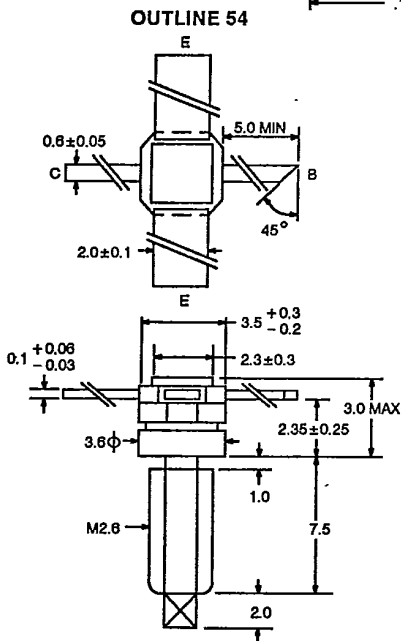
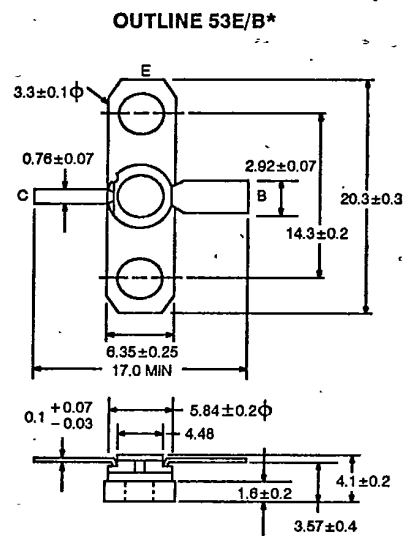
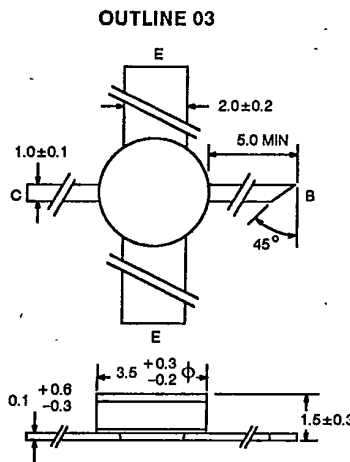
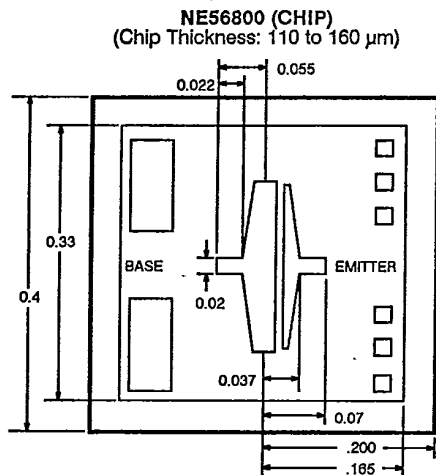

PERFORMANCE SPECIFICATIONS (T_A = 25°C)

SYMBOLS		PART NUMBER EIAJ ¹ REGISTERED NUMBER PACKAGE OUTLINE		NE56800		NE56803		NE56853		NE56854		NE56857		NE56887		
				00 (CHIP)		03		53		54		57		87		
PARAMETERS AND CONDITIONS		UNITS	MIN	TYP	MAX	MIN	TYP	MAX	MIN	TYP	MAX	MIN	TYP	MAX	TYP	MAX
f _s	Frequency where S ₂₁ ² = 0 dB	GHz	4	4.2		4	4.2		4	4.2		4	4.2		4.2	
S _{21E} ²	Insertion Gain at V _{CE} = 10 V, I _C = 80 mA, f = 2 GHz	dB		6	7.5											
P _{osc}	Oscillator Power Output at V _{CE} = 10 V, I _C = 80 mA, f = 6 GHz	mW														
MAG	Maximum Available Gain ³ at V _{CE} = 10 V, I _C = 80 mA, f = 2 GHz	dB	12	14.5		12	14		12	14		12	14			200
P _{1dB}	Output Power at the 1 dB Compression Point at V _{CE} = 10 V, I _C = 80 mA, f = 2 GHz	mW		320												
	Output Power at the 1 dB Compression Point at V _{CE} = 10 V, I _C = 80 mA, f = 4 GHz	mW		255												
GP	Power Gain at V _{CE} = 10 V, I _C = 80 mA, f = 2 GHz	dB		12												
	Power Gain at V _{CE} = 10 V, I _C = 80 mA, f = 4 GHz	dB		6												

ELECTRICAL CHARACTERISTICS (T_A = 25°C)

SYMBOLS		PART NUMBER EIAJ ¹ REGISTERED NUMBER PACKAGE OUTLINE		NE56800		NE56803		NE56853		NE56854		NE56857		NE56887		
				00 (CHIP)		03		53		54		57		87		
PARAMETERS AND CONDITIONS		UNITS	MIN	TYP	MAX	MIN	TYP	MAX	MIN	TYP	MAX	MIN	TYP	MAX	TYP	MAX
I _{CBO}	Collector Cutoff Current at V _{CB} = 10 V, I _E = 0	μA			5			5			5			5		5
I _{EB0}	Emitter Cutoff Current at V _{EB} = 1 V, I _C = 0	μA			5			5			5			5		5
I _{FE}	Forward Current Gain at V _{CE} = 10 V, I _C = 80 mA		20	60	160	20	60	160	20	60	160	20	60	160	20	60
C _{ob}	Output Capacitance ² at V _{CB} = 10 V, I _E = 0, f = 1 MHz	pF		0.55	0.80		0.55	0.80		0.55	0.80		0.55	0.80		0.55
R _{th}	Thermal Resistance (Junction-to-Case)	°C/W		25			60			28*			28*			0.80
P _T	Total Power Dissipation (T _C = 25°C)	W		1.5		1.5		1.5		1.5		1.5		1.5		1.5

Notes:

1. Electronic Industrial Association of Japan.
2. Emitter is grounded.
3. Maximum Available Gain (MAG) is calculated from the device S-Parameters using the equation,

$$MAG = \frac{|S_{21}|}{|S_{12}|} (K \pm \sqrt{K^2 - 1}) \quad K = \frac{1 + |\Delta|^2 - |S_{11}|^2 - |S_{22}|^2}{2|S_{12}| |S_{21}|} \quad \Delta = S_{11} S_{22} - S_{21} S_{12}$$

4. R_{th} (μ-c) for the NE56854 is 240°C/W.



ABSOLUTE MAXIMUM RATINGS (TA = 25°C)

SYMBOLS	PARAMETERS	UNITS	RATINGS
Vcbo	Collector to Base Voltage	V	25
Vceo	Collector to Emitter Voltage	V	15
Vebo	Emitter to Base Voltage	V	1.5
Ic	Collector Current	mA	150
Tj	Junction Temperature	°C	200
Tstg	Storage Temperature	°C	-65 to +200

TYPICAL PERFORMANCE CHARACTERISTICS (TA = 25°C)

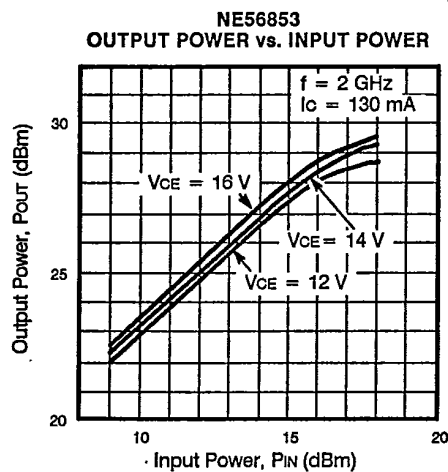
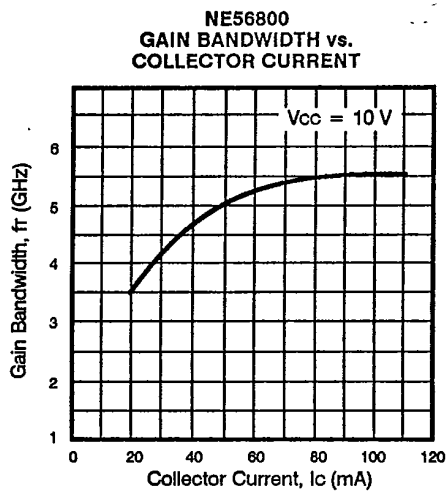
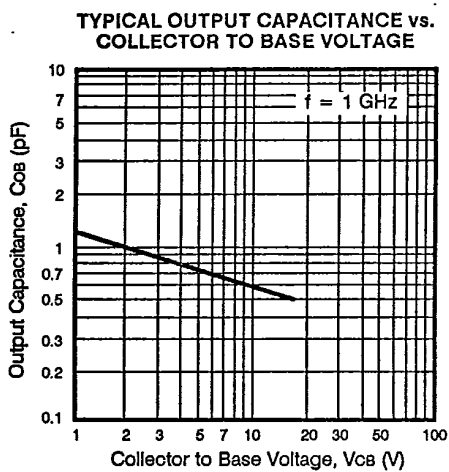

TYPICAL PERFORMANCE CHARACTERISTICS (TA = 25°C)

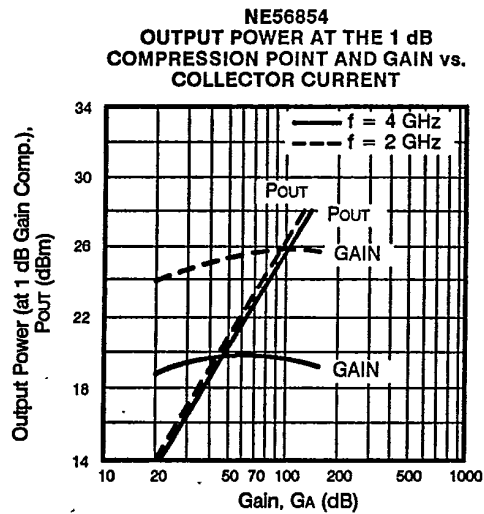
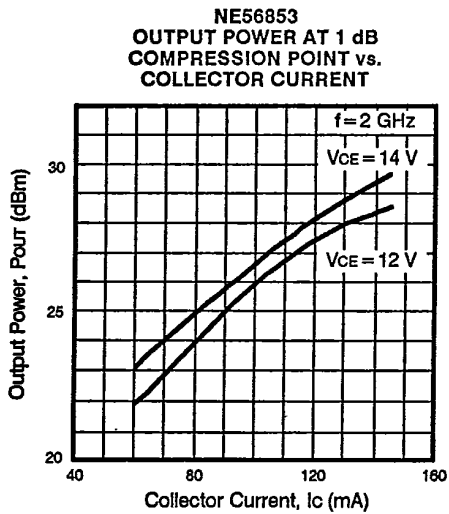
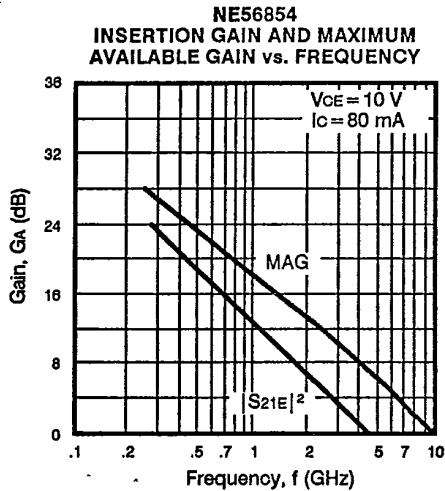
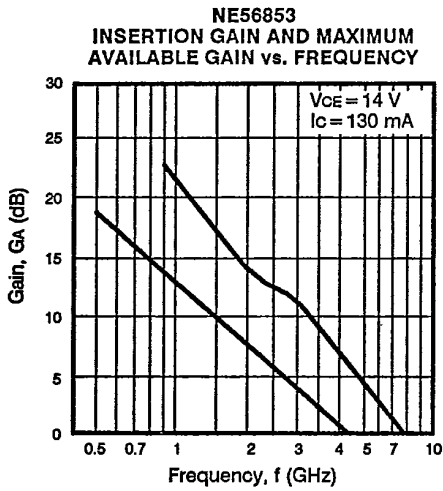
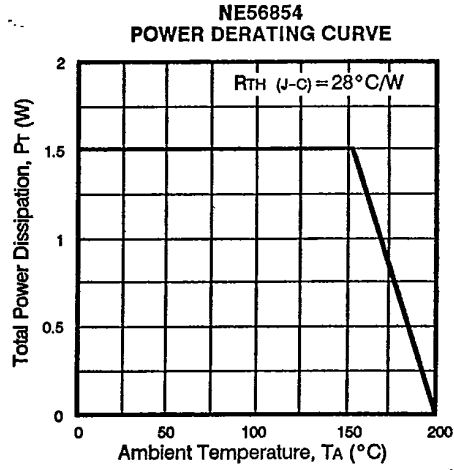
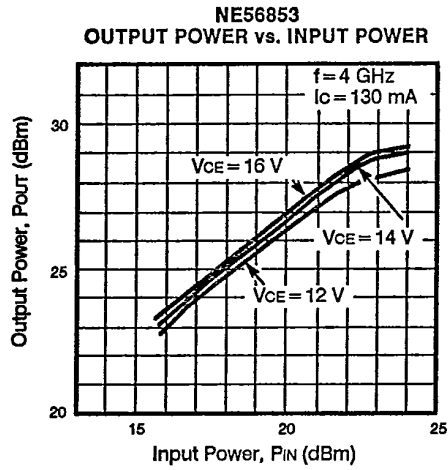

NEGATIVE RESISTANCE CHARACTERISTICS

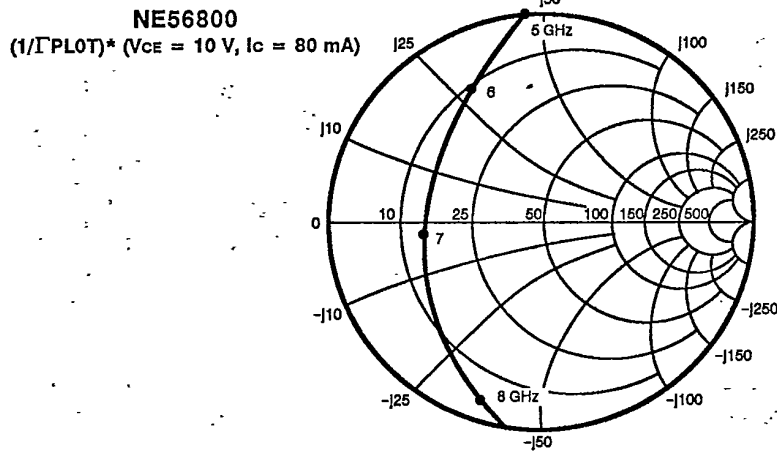

*Negative Resistance Characteristics are calculated by using the following formula:

$$\Gamma = S_{11} + \frac{S_{12} S_{21} \Gamma_L}{1 - S_{22} \Gamma_L}$$

, L = Load condition of the Output Terminal

TYPICAL COMMON EMITTER SCATTERING PARAMETERS

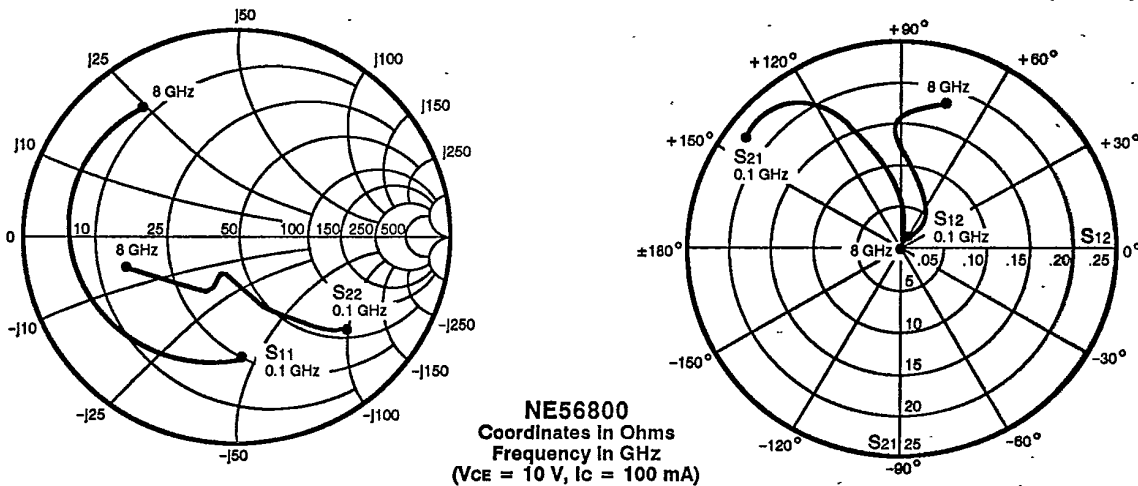

S-MAGN AND ANGLES:

V_{CE} = 10 V, I_C = 100 mA

FREQUENCY (MHz)	S ₁₁	S ₂₁	S ₁₂	S ₂₂				
100	.60	-85	22	142	.020	58	.77	-40
200	.67	-126	22	123	.030	42	.53	-63
300	.72	-143	16	112	.036	39	.40	-78
400	.74	-154	13	105	.037	38	.33	-86
500	.74	-162	10	103	.039	38	.28	-92
600	.74	-167	8	99	.040	42	.25	-97
700	.73	-170	7	96	.042	44	.23	-101
800	.73	-175	6	94	.043	46	.22	-105
900	.74	-178	6	93	.047	48	.22	-110
1000	.76	-180	5	91	.050	52	.22	-111
2000	.75	173	3	88	.067	74	.25	-115
3000	.76	168	2	78	.093	83	.29	-118
4000	.77	160	1	67	.122	86	.37	-119
5000	.79	147	1	58	.138	87	.37	-123
6000	.78	140	1	53	.164	90	.38	-139
7000	.77	132	1	42	.174	80	.43	-144
8000	.77	125	1	38	.180	76	.52	-163

TYPICAL COMMON EMITTER SCATTERING PARAMETERS

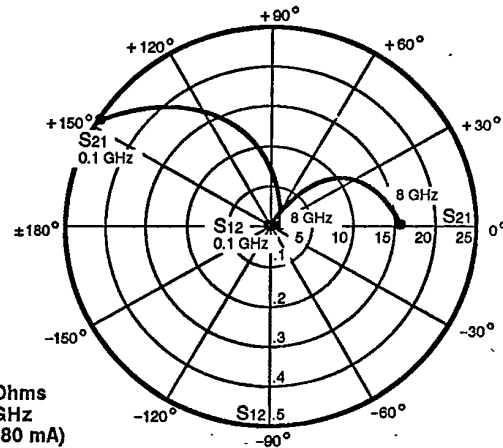
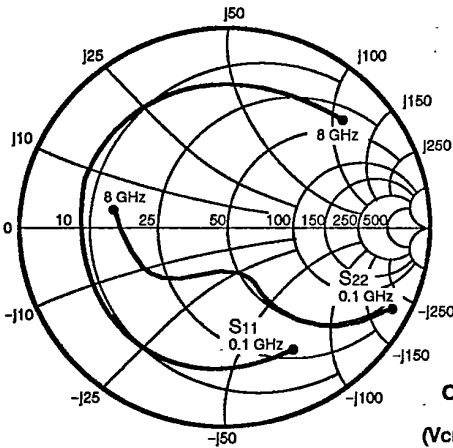

NE56803
Coordinates in Ohms
Frequency in GHz
(VCE = 10 V, IC = 80 mA)

S-MAGN AND ANGLES:

VCE = 10 V, IC = 80 mA

FREQUENCY (MHz)

	S11		S21		S12		S22	
100	.71	-60	24.33	148	.007	61	.90	-27
200	.73	-104	18.96	125	.019	49	.68	-47
300	.69	-127	13.93	113	.028	39	.52	-56
400	.71	-142	11.28	103	.030	34	.44	-62
500	.71	-153	9.12	97	.036	34	.35	-65
600	.71	-160	7.88	93	.038	34	.33	-66
700	.73	-167	6.74	89	.039	35	.28	-72
800	.71	-173	6.03	84	.041	35	.27	-70
900	.73	-176	5.20	81	.040	37	.24	-78
1000	.73	178	4.84	77	.049	36	.23	-77
2000	.71	158	2.52	53	.089	46	.23	-99
3000	.73	136	1.72	31	.123	47	.30	-113
4000	.74	118	1.31	12	.163	43	.35	-128
5000	.74	98	1.10	-4	.212	36	.41	-141
6000	.74	79	.88	-20	.252	24	.46	-158
7000	.78	59	.77	-35	.295	14	.49	-172
8000	.80	43	.66	-44	.326	2	.54	173

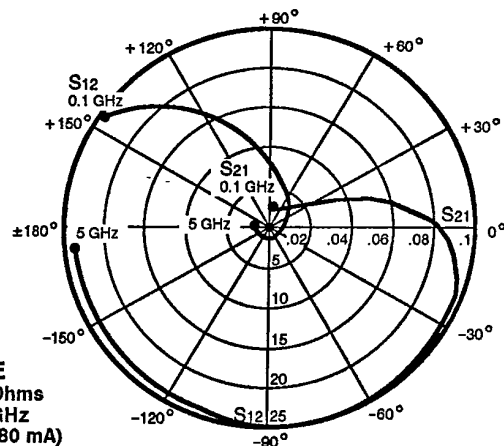
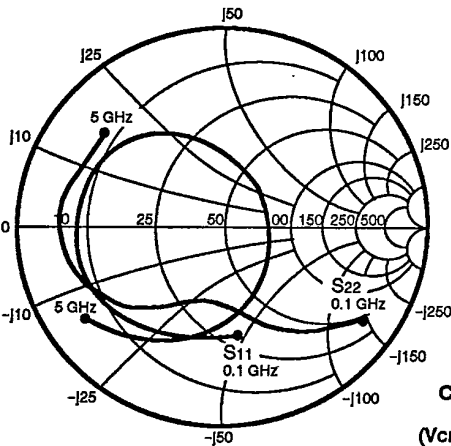

NE56853E
Coordinates in Ohms
Frequency in GHz
(VCE = 10 V, IC = 80 mA)

S-MAGN AND ANGLES:

VCE = 10 V, IC = 80 mA

FREQUENCY (MHz)

	S11		S21		S12		S22	
100	.66	-78	23.66	144	.012	63	.85	-33
200	.62	-121	17.46	121	.017	36	.66	-54
300	.68	-140	13.22	105	.030	36	.54	-69
400	.70	-154	10.57	97	.031	25	.46	-78
500	.71	-162	8.60	88	.041	25	.41	-84
600	.72	-169	7.34	81	.032	21	.40	-90
700	.71	-175	6.35	75	.043	22	.38	-93
800	.72	-179	5.62	71	.036	18	.39	-98
900	.71	176	5.03	65	.044	19	.39	-102
1000	.71	174	4.56	61	.043	18	.39	-104
2000	.60	138	2.53	15	.071	8	.51	-124
3000	.35	77	1.97	-33	.101	-21	.67	-145
4000	.43	-77	1.33	-98	.106	-87	.76	-179
5000	.80	-144	.67	-162	.092	-171	.71	142

NE568 SERIES

TYPICAL COMMON EMITTER SCATTERING PARAMETERS

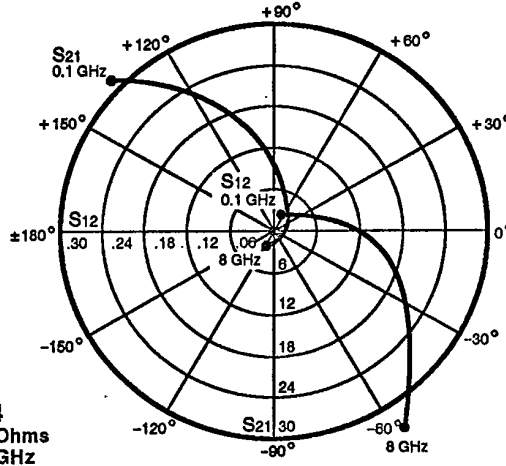
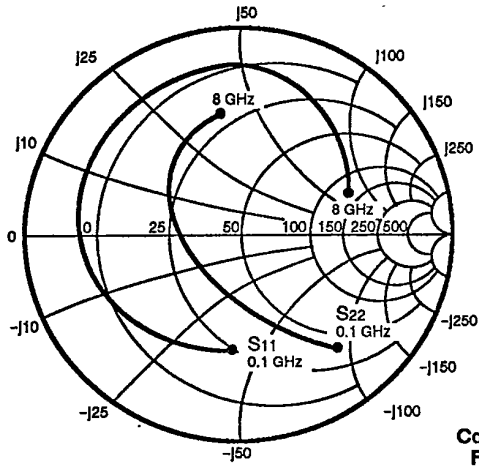

NE56854
Coordinates in Ohms
Frequency in GHz
(V_{CE} = 10 V, I_C = 100 mA)

S-MAGN AND ANGLES:

V_{CE} = 10 V, I_C = 100 mA

FREQUENCY (MHz)

	S ₁₁		S ₂₁		S ₁₂		S ₂₂	
100	.59	-95	32.62	136	.022	44	.73	-49
200	.66	-133	21.60	115	.031	35	.47	-75
300	.70	-151	15.40	105	.035	30	.36	-95
400	.69	-163	11.80	94	.037	30	.30	-108
500	.71	-171	9.64	90	.040	28	.26	-117
600	.74	-178	8.00	84	.043	28	.24	-126
700	.77	178	6.97	80	.044	26	.23	-136
800	.74	175	6.08	75	.046	28	.22	-142
900	.72	168	5.34	73	.046	29	.20	-149
1000	.74	164	4.78	68	.048	29	.20	-156
1500	.78	148	3.15	51	.059	27	.23	-179
2000	.80	134	2.38	36	.071	25	.27	163
2500	.81	125	1.84	21	.095	20	.32	153
3000	.84	116	1.51	8	.092	11	.36	144
3500	.84	108	1.27	-4	.102	8	.42	137
4000	.88	100	1.12	-16	.119	2	.48	130
4500	.83	94	.90	-27	.114	-4	.51	125
5000	.85	86	.82	-37	.127	-10	.56	118
5500	.81	78	.73	-46	.135	-17	.57	113
6000	.79	72	.63	-52	.127	-18	.55	106
6500	.78	67	.69	-56	.192	-17	.58	113
7000	.75	56	.67	-70	.216	-30	.61	107
7500	.70	44	.67	-79	.258	-42	.61	102
8000	.59	24	.68	-93	.343	-58	.61	98

TYPICAL COMMON COLLECTOR SCATTERING PARAMETERS

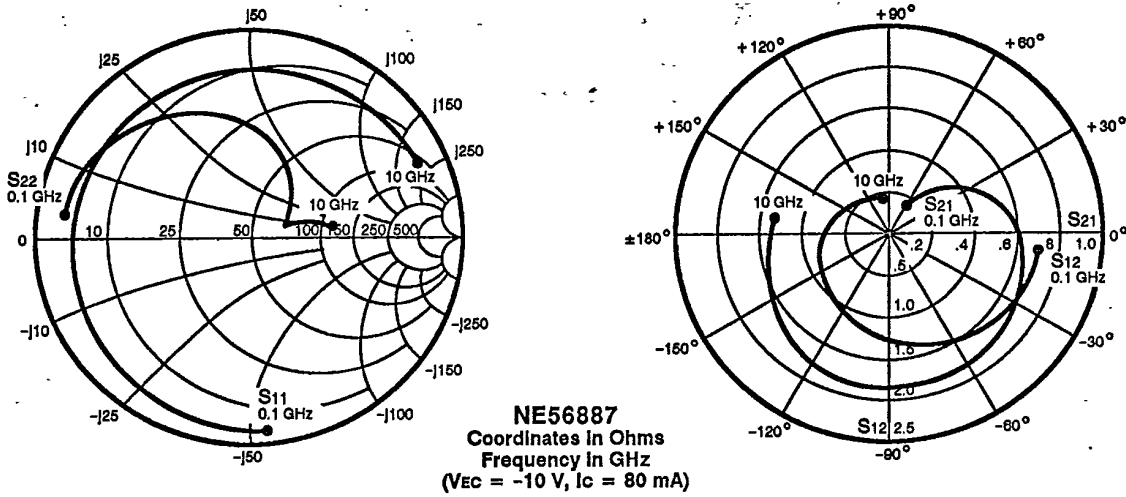

S-MAGN AND ANGLES:

$V_{EC} = -10\text{ V}$, $I_C = 80\text{ mA}$

FREQUENCY (MHz)

FREQUENCY (MHz)	S ₁₁	S ₂₁	S ₁₂	S ₂₂
100	.97 -6	1.82 -7	.039 39	.86 172
200	.96 -9	1.86 -9	.063 52	.87 170
300	.97 -13	1.87 -13	.090 56	.86 163
400	.97 -18	1.83 -15	.118 57	.85 161
500	.96 -23	1.81 -20	.147 59	.85 158
600	1.00 -26	1.88 -21	.172 55	.84 153
700	.97 -30	1.83 -25	.202 53	.82 152
800	.96 -35	1.82 -28	.223 54	.83 149
900	.97 -39	1.83 -31	.248 48	.81 143
1000	.97 -43	1.78 -33	.283 47	.80 141
1100	.98 -47	1.77 -37	.305 45	.80 138
1200	.96 -53	1.77 -39	.327 41	.77 134
1300	.97 -56	1.74 -42	.350 38	.78 133
1400	.98 -60	1.75 -45	.370 35	.76 129
1500	.97 -65	1.73 -46	.393 32	.74 124
1600	.96 -69	1.68 -52	.419 28	.75 123
1700	.95 -73	1.69 -54	.433 28	.73 120
1800	.93 -76	1.68 -56	.450 23	.72 118
1900	.95 -80	1.65 -57	.470 20	.71 114
2000	.92 -84	1.59 -57	.489 22	.70 118
3000	.88 -119	1.39 -83	.634 -6	.57 88
4000	.87 -151	1.22 -104	.703 -35	.42 62
5000	.85 179	1.07 -127	.735 -60	.32 40
6000	.83 150	.92 -148	.734 -85	.21 22
7000	.83 118	.79 -171	.715 -106	.18 17
8000	.85 88	.69 164	.691 -134	.18 19
9000	.85 53	.54 139	.609 -159	.27 19
10000	.88 27	.43 115	.543 175	.38 11

