

6, 8 PIN DIP 250 V BREAKDOWN VOLTAGE 1-CH, 2-CH OPTICAL COUPLED MOSFET

PS7122A-1A
PS7122A-2A
PS7122AL-1A
PS7122AL-2A

FEATURES

- **1 CHANNEL TYPE:**
1a output
- **OR 2 CHANNEL TYPE:**
1a + 1a output
- **LOW LED OPERATING CURRENT:**
 $I_F = 2 \text{ mA}$
- **DESIGNED FOR AC/DC SWITCHING LINE CHANGER**
- **SMALL PACKAGE:**
6, 8 Pin DIP
- **LOW OFFSET VOLTAGE**
- **SURFACE MOUNT TYPE LEAD AVAILABLE:**
PS7122AL-1A, 2A

DESCRIPTION

PS7122A-1A,-2A and PS7122AL-1A,-2A are solid state relays containing GaAs LEDs on the light emitting side (input side) and MOSFETs on the output side.

They are suitable for analog signal control because of their low offset and high linearity.

APPLICATIONS

- EXCHANGE EQUIPMENT
- MEASUREMENT EQUIPMENT
- FA/OA EQUIPMENT

ELECTRICAL CHARACTERISTICS ($T_A = 25^\circ\text{C}$)

PART NUMBER			PS7122A-1A, 2A, PS7122AL-1A, 2A			
SYMBOLS	PARAMETERS	UNITS	MIN	TYP	MAX	
Diode	V_F	Forward Voltage, $I_F = 10 \text{ mA}$		1.2	1.4	
	I_R	Reverse Current, $V_R = 5 \text{ V}$	μA		5.0	
MOSFET	I_{Loff}	Off-State Leakage Current, $V_D = 250 \text{ V}$	μA	0.03	1.0	
	C_{OUT}	Output Capacitance, $V_D = 0 \text{ V}$, $f = 1 \text{ MHz}$	pF/ch	120		
Coupled	I_{Fon}	LED On-state Current, $I_L = 200 \text{ mA}$	mA		2.0	
	R_{on1}	On-State Resistance, $I_F = 10 \text{ mA}$, $I_L = 10 \text{ mA}$	Ω	4.5	8.0	
						R_{on2}
	t_{on}	Turn-On Time ¹ , $I_F = 10 \text{ mA}$, $V_O = 5 \text{ V}$, $PW \geq 10 \text{ ms}$	ms		0.5	1.5
	t_{off}	Turn-Off Time ¹ , $I_F = 10 \text{ mA}$, $V_O = 5 \text{ V}$, $PW \geq 10 \text{ ms}$	ms		0.04	0.2
	Ri-O	Isolation Resistance, $V_{in-out} = 1.0 \text{ kVDC}$	Ω	10^9		
	CI-O	Isolation Capacitance, $V = 0 \text{ V}$, $f = 1 \text{ MHz}$	pF/ch		1.1	

Note:

1. Test circuit for Switching Time

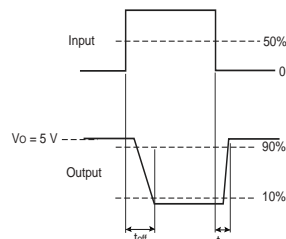
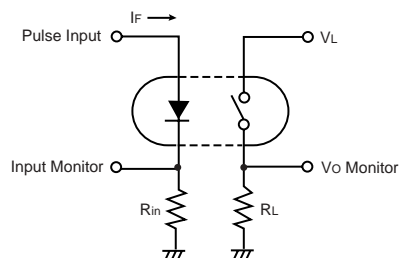

PS7122A-1A, PS7122AL-1A

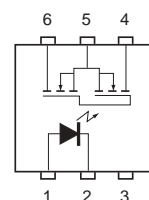

PS7122A-2A, PS7122AL-2A

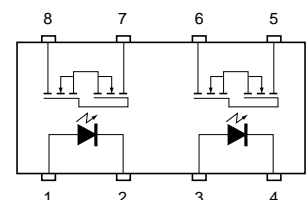

PS7122A-1A, -2A, PS7122AL-1A, -2A

ABSOLUTE MAXIMUM RATINGS¹ (T_A = 25°C)

SYMBOLS	PARAMETERS	UNITS	RATINGS	
			PS7122A-1A PS7122AL-1A	PS7122A-2A PS7122AL-2A
Diode				
V _R	Reverse Voltage	V	5	
I _F	Forward Current (DC)	mA	50	
P _D	Power Dissipation	mW/ch	50	
I _{FP}	Peak Forward Current ²	A	1	
MOSFET				
V _L	Break Down Voltage	V	250	
I _L	Continuous Load Current ³	Connection A	200	
		Connection B	350	–
		Connection C	500	–
I _{LP}	Pulse Load Current ⁴ (AC/DC Connection)	mA	400	
P _D	Power Dissipation	mW/ch	560	375
Coupled				
BV	Isolation Voltage ⁵	Vr.m.s.	1500	
P _T	Total Power Dissipation	mW	610	850
T _A	Operating Ambient Temp.	°C	-40 to +80	
T _{STG}	Storage Temperature	°C	-40 to +100	

Notes:

- Operation in excess of any one of these parameters may result in permanent damage.
- PW = 100 μs, Duty Cycle = 1%.
- Conditions: I_F ≥ 2 mA. The following types of load connections are available.

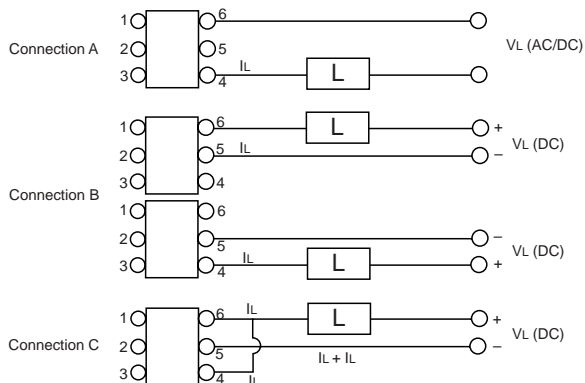

- PW = 100 ms, 1 shot.
- AC voltage for 1 minute at T_A = 25 °C, RH = 60 % between input and output.

RECOMMENDED OPERATING CONDITIONS (T_A = 25 °C)

SYMBOL	PARAMETER	UNITS	MIN	TYP	MAX
I _F	LED Operating Current	mA	2	10	20
V _F	LED Off Voltage	V	0		0.5

ORDERING INFORMATION

PART NUMBER	PACKAGE	PACKING STYLE
PS7122A-1A	6 Pin DIP	Magazine case, 50 pcs
PS7122AL-1A		Embossed Tape, 1000 pcs/reel
PS7122AL-1A-E3		
PS7122AL-1A-E4		
PS7122A-2A	8 Pin DIP	Magazine case, 50 pcs
PS7122AL-2A		Embossed Tape, 1000 pcs/reel
PS7122AL-2A-E3		
PS7122AL-2A-E4		

TYPICAL PERFORMANCE CURVES ($T_A = 25^\circ\text{C}$)

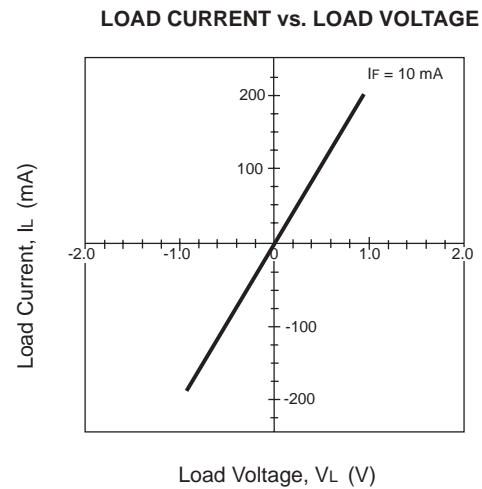
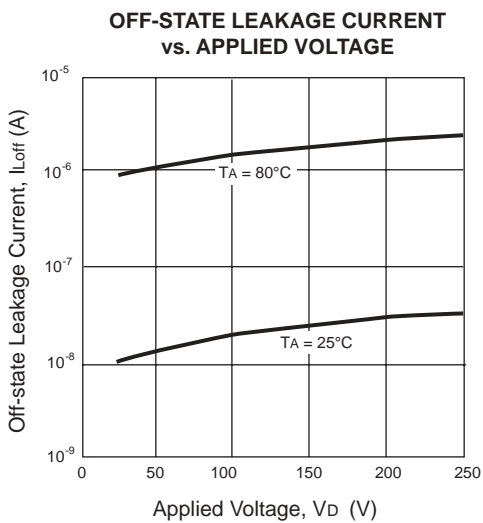
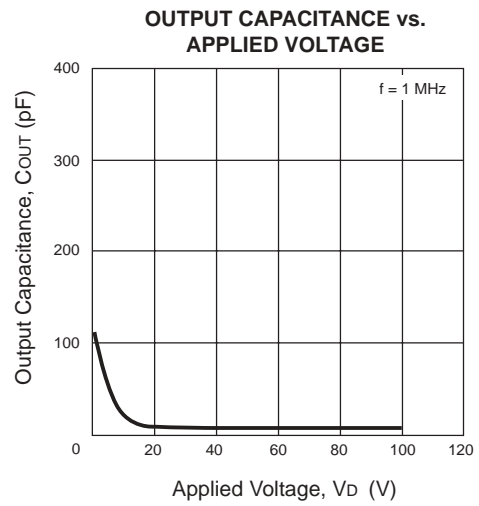
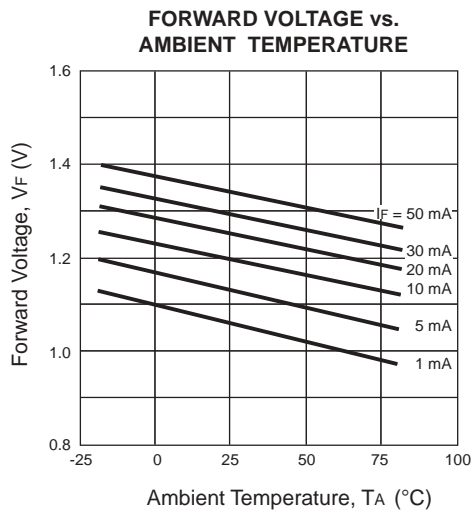
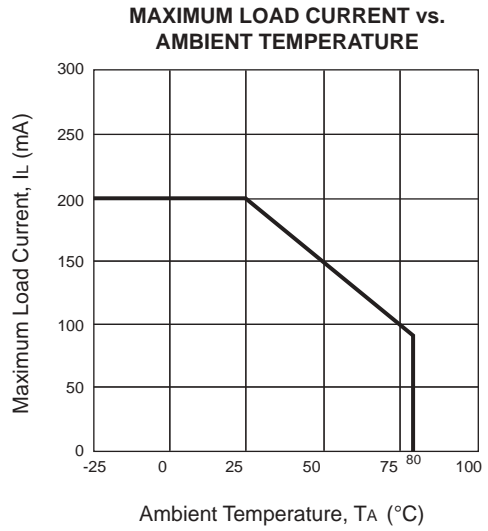
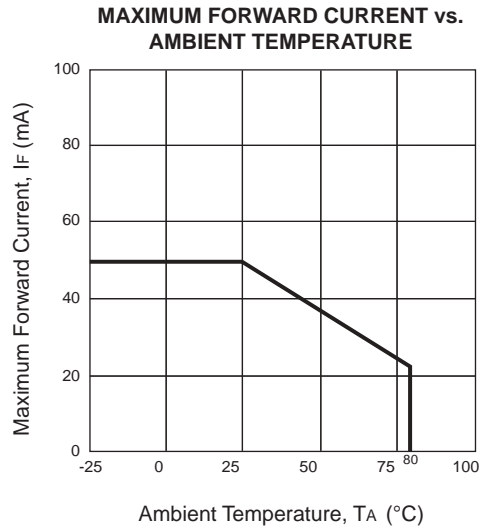

TYPICAL PERFORMANCE CURVES (TA = 25 °C)

NORMALIZED ON-STATE RESISTANCE vs. AMBIENT TEMPERATURE

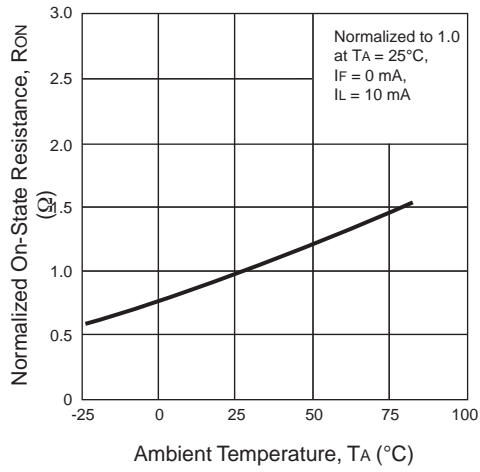

ON-STATE RESISTANCE DISTRIBUTION

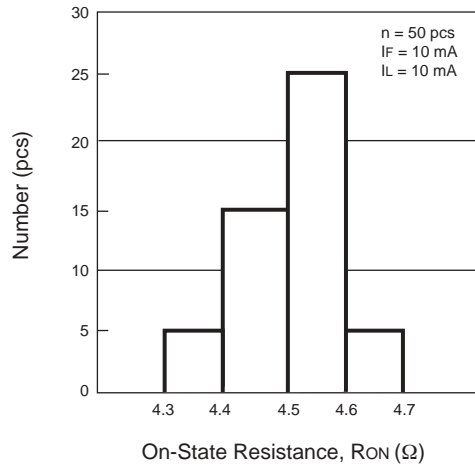

TURN-ON TIME vs. FORWARD CURRENT

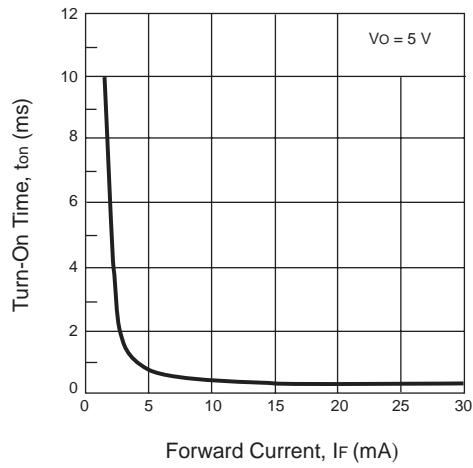

TURN-OFF TIME vs. FORWARD CURRENT

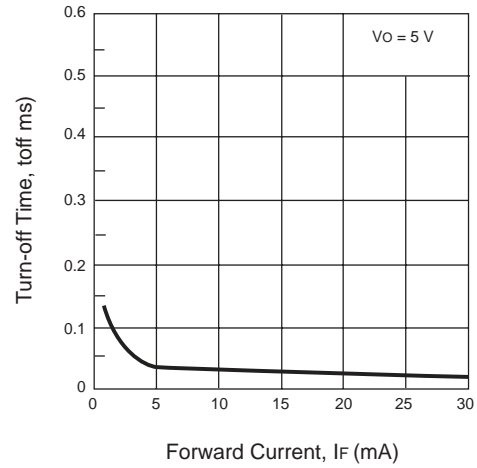

TURN-ON TIME DISTRIBUTION

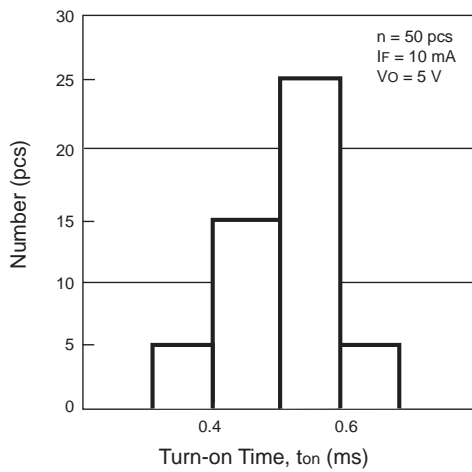

TURN-OFF TIME DISTRIBUTION

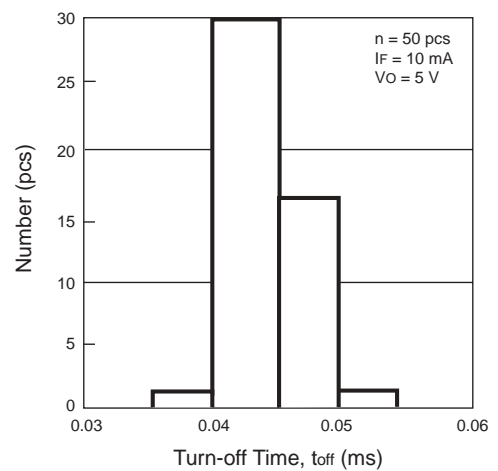

TYPICAL PERFORMANCE CURVES (TA = 25 °C)

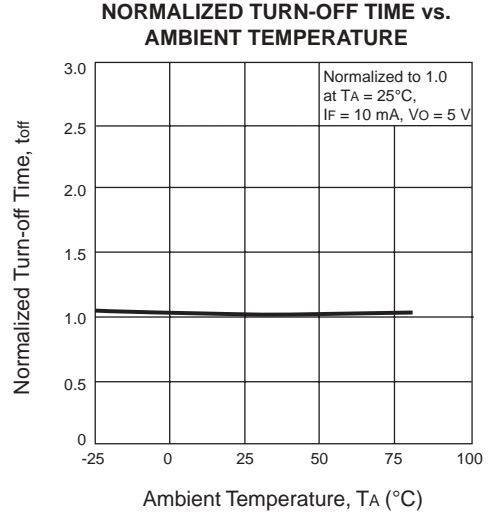
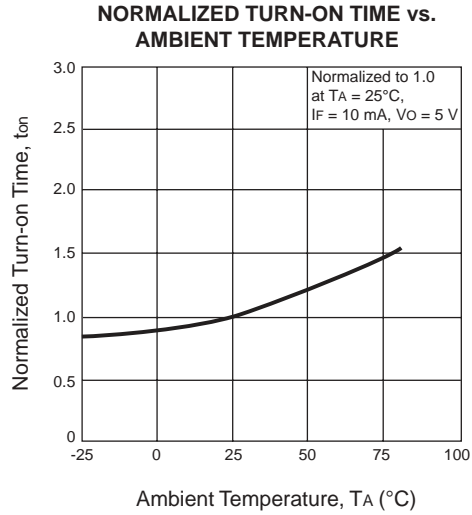

OUTLINE DIMENSIONS (Units in mm)

PS7122A-1A

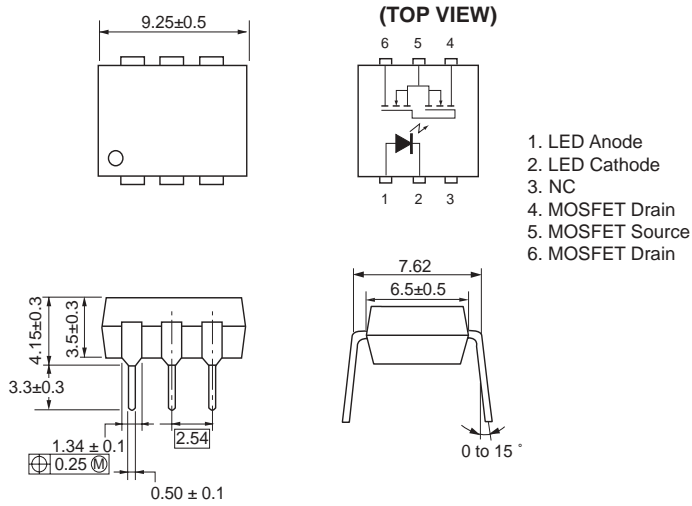

PS7122AL-1A

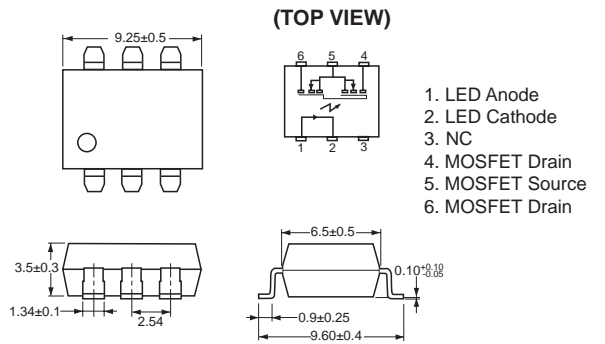

PS7122A-2A

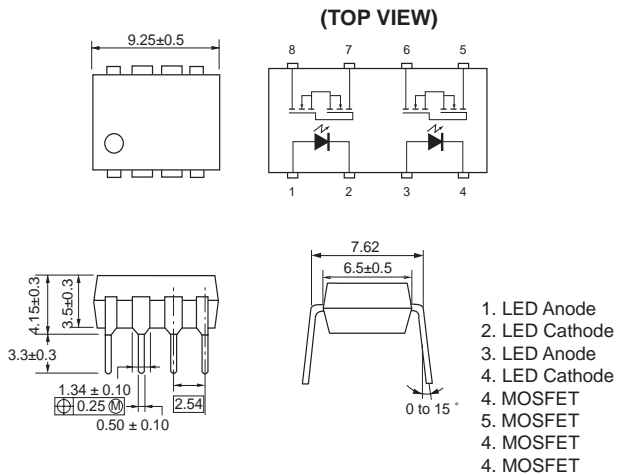

PS7122AL-2A

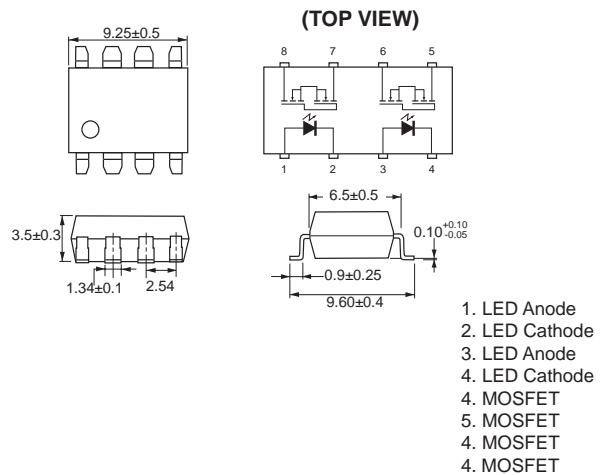

RECOMMENDED SOLDERING CONDITIONS

(1) Infrared reflow soldering

- Peak reflow temperature 235 °C or below (package surface temperature)
- Time of temperature higher than 210 °C 30 seconds or less
- Number of reflows Two
- Flux Rosin flux containing small amount of chlorine
(The flux with a maximum chlorine content of 0.2 Wt % is recommended.)

Recommended Temperature Profile of Infrared Reflow

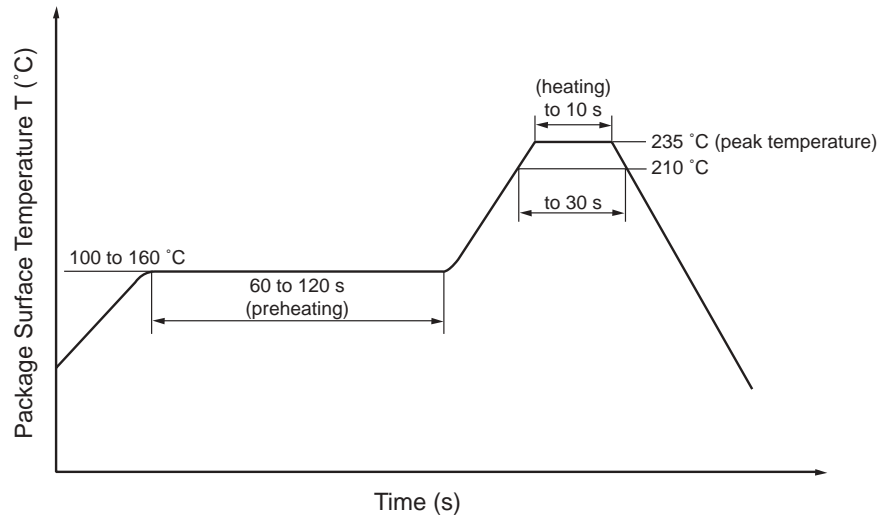

(2) Dip soldering

- Temperature 260 °C or below (molten solder temperature)
- Time 10 seconds or less
- Number of times One
- Flux Rosin flux containing small amount of chlorine
(The flux with a maximum chlorine content of 0.2 Wt % is recommended.)

(3) Cautions

- Fluxes
Avoid removing the residual flux with freon-based cleaning solvent.

EXCLUSIVE NORTH AMERICAN AGENT FOR **NEC** RF, MICROWAVE & OPTOELECTRONIC SEMICONDUCTORS