

FEATURES

- **DESIGNED FOR AC/DC SWITCHING APPLICATIONS**
- **IDEAL FOR ANALOG SIGNAL CONTROL**
- **1 CHANNEL TYPE:**
1a Output
- **LOW LED OPERATING CURRENT:**
 $I_F = 2 \text{ mA}$
- **SMALL PACKAGE:**
6 Pin DIP
- **LOW OFFSET VOLTAGE**
- **SURFACE MOUNT AVAILABLE**

DESCRIPTION

PS7160-1A and PS7160L-1A are solid state relays containing a GaAs LED on the light emitting side (input side) and MOSFETs on the output side. They are suitable for analog signal control because of their low offset and high linearity.

APPLICATIONS

- **EXCHANGE EQUIPMENT**
- **MEASUREMENT EQUIPMENT**
- **FA/OA EQUIPMENT**

PS7160-1A, PS7160L-1A

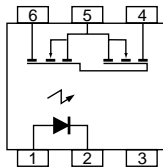

ELECTRICAL CHARACTERISTICS (T_A = 25°C)

PART NUMBER			PS7160-1A, PS7160L-1A			
	SYMBOLS	PARAMETERS	UNITS	MIN	TYP	MAX
Diode	V _F	Forward Voltage, I _F = 10 mA	V		1.2	1.4
	I _R	Reverse Current, V _R = 5 V	μA			5.0
MOSFET	RON1	On-Stage Resistance, I _F = 10 mA, I _L = 10 mA	Ω		42	50
	RON2	On-Stage Resistance, I _F = 10 mA, I _L = 90 mA, t _s ≤ 10 mS	Ω		33	50
	I _{LOFF}	Off-Stage Leakage Current, V _D = 600 V	μA		0.03	1
	C _{OUT}	Output Capacitance, V _D = 0 V, f = 1 MHz	pF		110	
COUPLED	t _{ON}	Turn-on Time ¹ I _F = 10 mA, V _L = 5 V, R _L = 500 Ω, PW ≥ 10 ms	ms		0.8	1.5
	t _{OFF}	Turn-off Time ¹ I _F = 10 mA, V _L = 5 V, R _L = 500 Ω, PW ≥ 10 ms	ms		0.06	0.2
	R _{I-O}	Isolation Resistance, V _{I-O} = 1.0 kV	Ω	10 ⁹		
	C _{I-O}	Isolation Capacitance, V = 0 V, f = 1 MHz	pF		1.1	

Note:

1. Test Circuit for Switching time

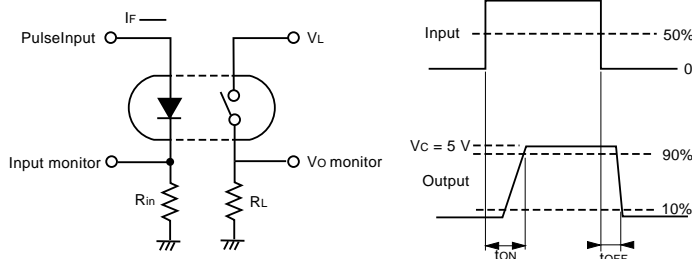

ABSOLUTE MAXIMUM RATINGS¹ (T_A = 25°C)

SYMBOLS	PARAMETERS	UNITS	RATINGS
Diode			
I _F	Forward Current (DC)	mA	50
V _R	Reverse Voltage	V	5
P _D	Power Dissipation	mW	50
I _{FP}	Peak Forward Current ²	A	1
MOSFET			
V _L	Break Down Voltage	V	600
I _L	Continuous Load Current ³	Connection A	mA
		Connection B	mA
		Connection C	mA
I _{LP}	Pulse Load Current ⁴ (AC/DC Connection)	mA	250
P _D	Power Dissipation	mW	560
Coupled			
BV	Isolation Voltage ⁵	Vr.m.s.	1500
P _T	Total Power Dissipation	mW	610
T _A	Operating Ambient Temp.	°C	-40 to +80
T _{STG}	Storage Temperature	°C	-40 to +100

Notes:

1. Operation in excess of any one of these parameters may result in permanent damage.
2. PW = 100 μs, Duty Cycle = 1 %
3. Conditions: I_F ≥ 2 mA. The following types of load connections are available:

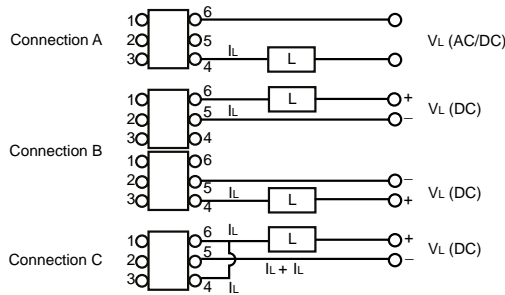

4. PW = 100 ms, 1 shot.
5. AC voltage for 1 minute at T_A = 25 °C, RH = 60 % between input and output.

OUTLINE DIMENSIONS (Units in mm)

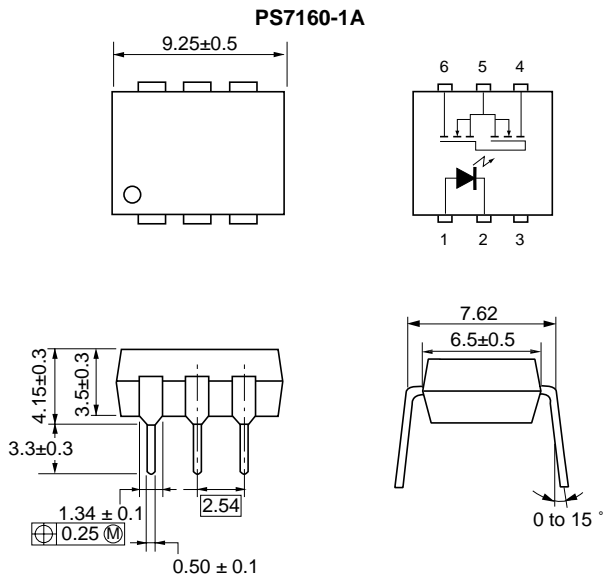

RECOMMENDED OPERATING CONDITIONS (T_A = 25°C)

PART NUMBER		PS7160-1A, PS7160L-1A			
SYMBOLS	PARAMETERS	UNITS	MIN	TYP	MAX
I _F	LED Operating Current	mA	2	10	20
V _F	LED Off Voltage	V	0		0.5

ORDERING INFORMATION

PART NUMBER	PACKAGE	PACKING STYLE
PS7160-1A	6-pin DIP	Magazine case 50 pcs
PS7160L-1A		
PS7160L-1A-E3		Embossed Tape 1000 pcs/reel
PS7160L-1A-E4		

PIN CONNECTION (Top View)

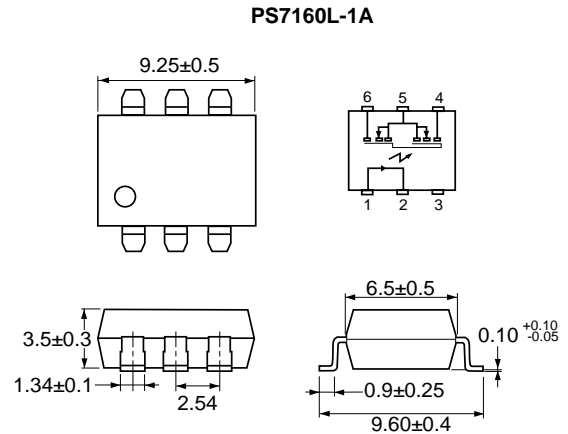
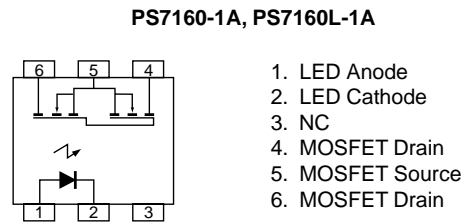

TYPICAL PERFORMANCE CURVES (TA = 25 °C)

MAXIMUM FORWARD CURRENT vs. AMBIENT TEMPERATURE

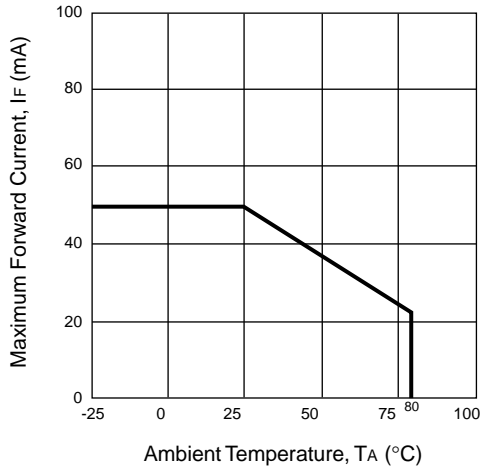

MAXIMUM LOAD CURRENT vs. AMBIENT TEMPERATURE

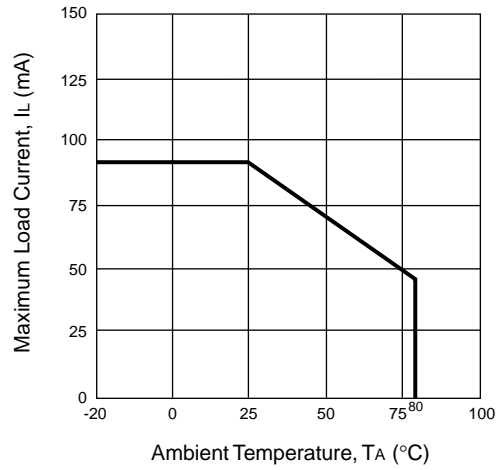

FORWARD VOLTAGE vs. AMBIENT TEMPERATURE

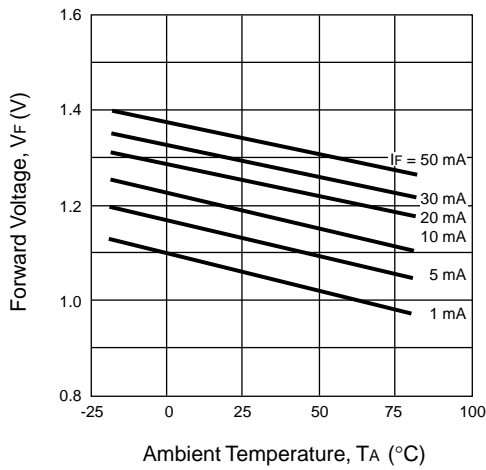

OUTPUT CAPACITANCE vs. SUPPLY VOLTAGE

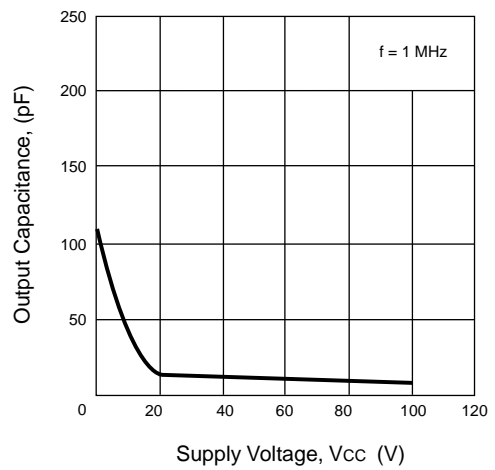

NORMALIZED ON-STATE RESISTANCE vs. AMBIENT TEMPERATURE

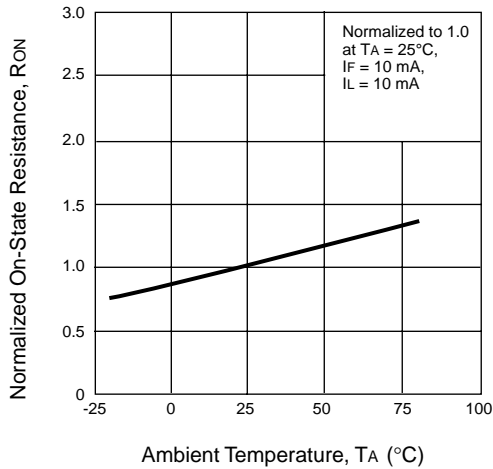

ON-STATE RESISTANCE DISTRIBUTION

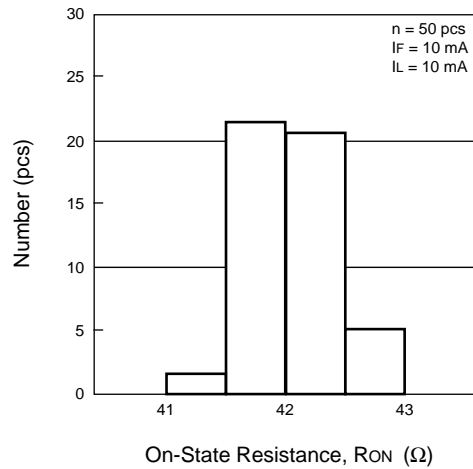

TYPICAL PERFORMANCE CURVES (TA = 25 °C)

OFF-STATE LEAKAGE CURRENT vs. SUPPLY VOLTAGE

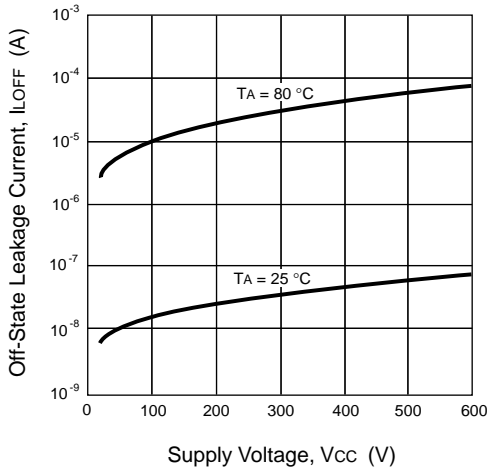

LOAD CURRENT vs. LOAD VOLTAGE

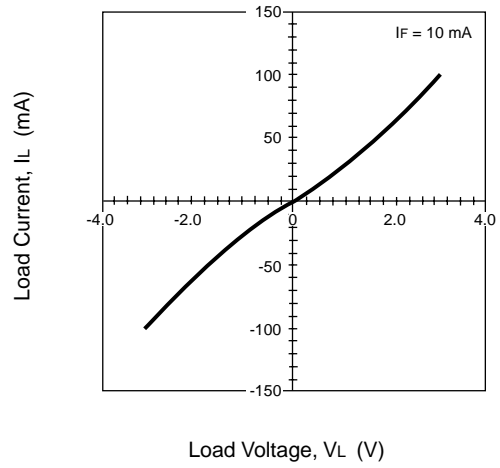

TURN-ON TIME vs. FORWARD CURRENT

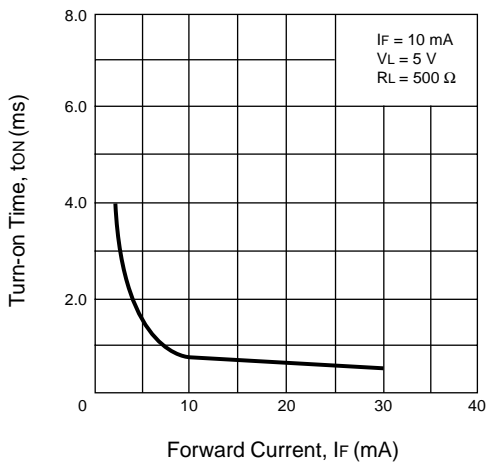

TURN-OFF TIME vs. FORWARD CURRENT

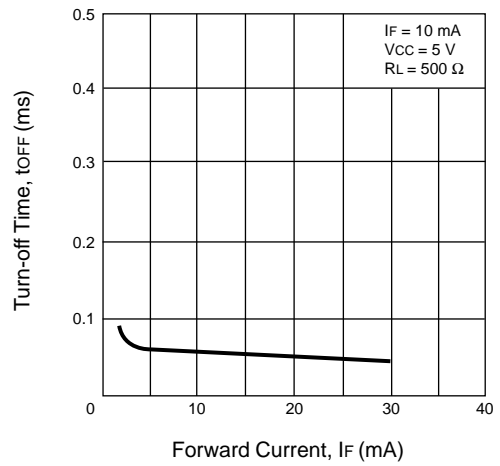

TURN-ON TIME DISTRIBUTION

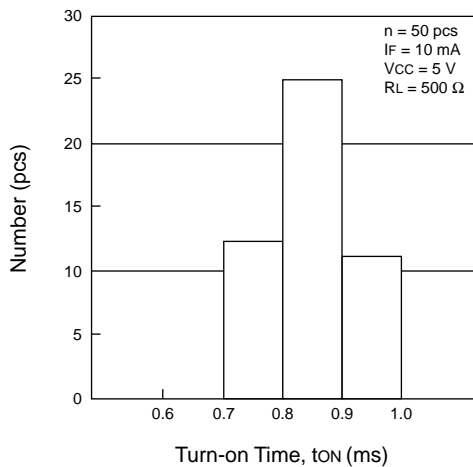

TURN-OFF TIME DISTRIBUTION

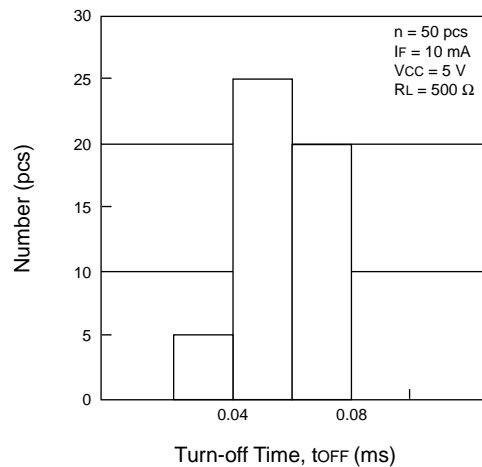

TYPICAL PERFORMANCE CURVES (TA = 25 °C)

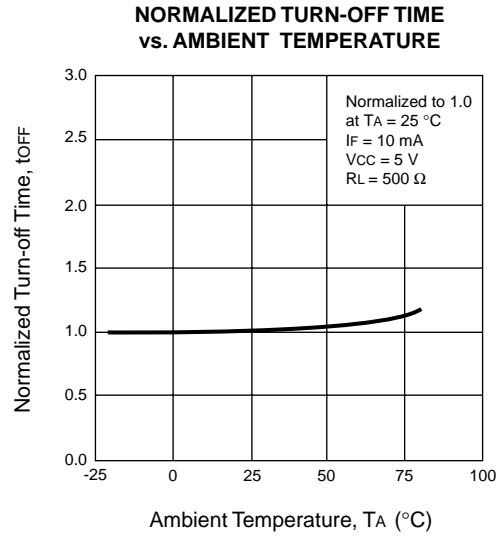
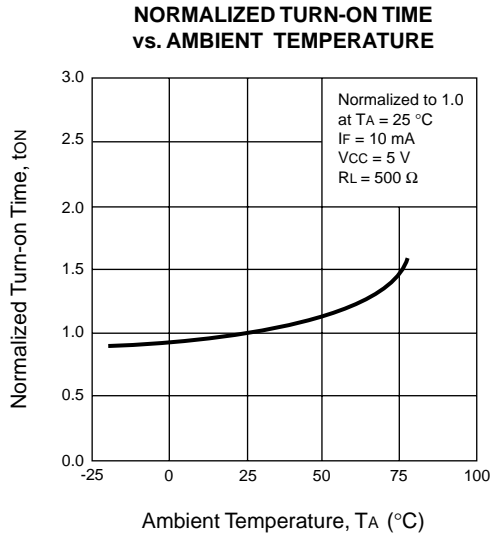

TAPING SPECIFICATIONS (Units in mm)

OUTLINE AND DIMENSIONS (TAPE)

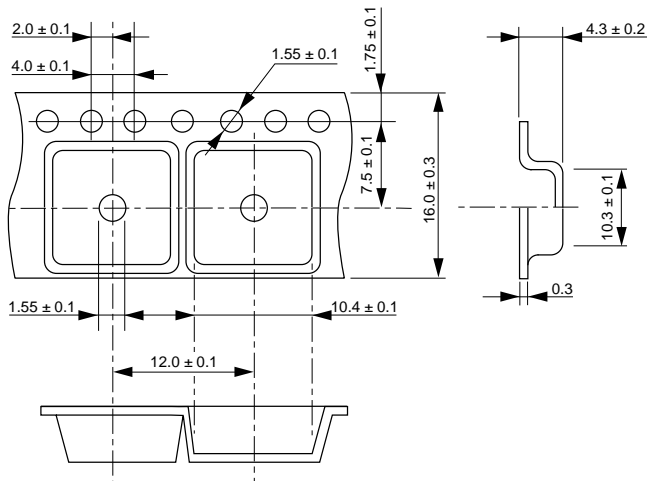

OUTLINE AND DIMENSIONS (REEL)

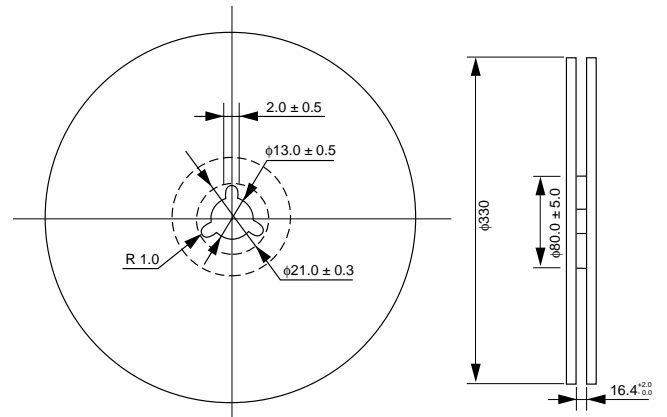

Packaging : 1000 pcs/reel

TAPING DIRECTION

PS7160L-1A-E3

PS7160L-1A-E4

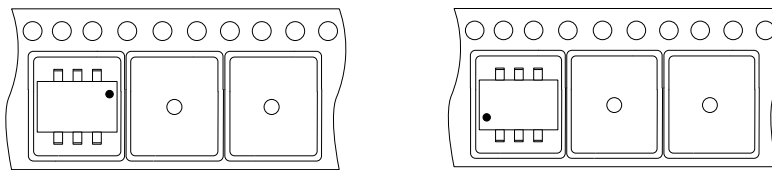

RECOMMENDED SOLDERING CONDITIONS

(1) Infrared reflow soldering

- Peak reflow temperature 235 °C or below (package surface temperature)
- Time of temperature higher than 210 °C 30 seconds or less
- Number of reflows Two
- Flux Rosin flux containing small amount of chlorine
(The flux with a maximum chlorine content of 0.2 Wt % is recommended.)

Recommended Temperature Profile of Infrared Reflow

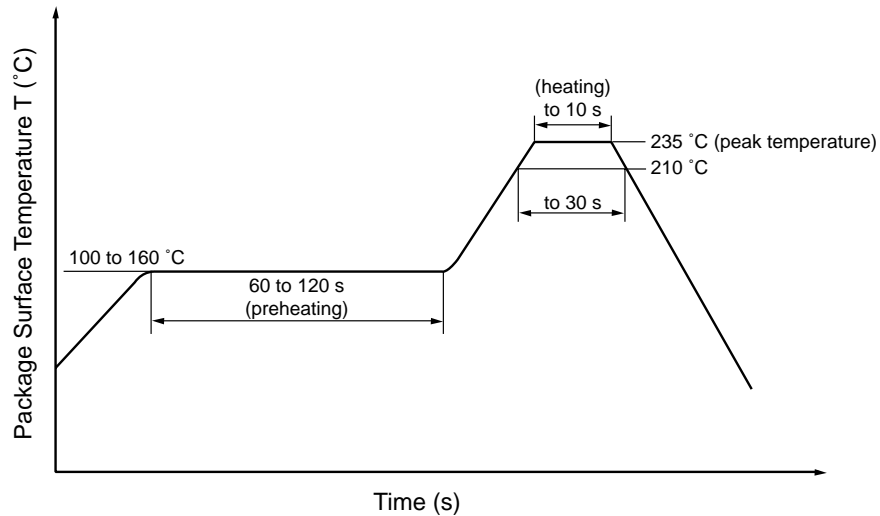

(2) Dip soldering

- Temperature 260 °C or below (molten solder temperature)
- Time 10 seconds or less
- Number of times One
- Flux Rosin flux containing small amount of chlorine
(The flux with a maximum chlorine content of 0.2 Wt % is recommended.)

(3) Cautions

- Fluxes
Avoid removing the residual flux with freon-based cleaning solvent.

EXCLUSIVE NORTH AMERICAN AGENT FOR **NEC** RF, MICROWAVE & OPTOELECTRONIC SEMICONDUCTORS

CEL CALIFORNIA EASTERN LABORATORIES • Headquarters • 4590 Patrick Henry Drive • Santa Clara, CA 95054-1817 • (408) 988-3500 • Telex 34-6393 • FAX (408) 988-0279
24-Hour Fax-On-Demand: 800-390-3232 (U.S. and Canada only) • Internet: <http://WWW.CEL.COM>

DATA SUBJECT TO CHANGE WITHOUT NOTICE

07/27/2001