

FEATURES

- **HIGH ISOLATION VOLTAGE:**
BV : 3750 Vr.m.s.
- **1 CHANNEL TYPE**
1a output
- **DESIGNED FOR AC/DC SWITCHING LINE CHANGER**
- **SMALL PACKAGE:**
6 pin DIP
- **LOW OFFSET VOLTAGE:**
- **SURFACE MOUNT TYPE LEAD:**
PS7341L-1A
- **LOW LED OPERATING CURRENT**
IF = 2 mA
- **AVAILABLE IN TAPE AND REEL**

DESCRIPTION

PS7341-1A and PS7341L-1A are solid state relays containing a GaAs LED on the light emitting side (input side) and MOS FETs on the output side. They are suitable for analog signal control because of their low offset and high linearity.

APPLICATIONS

- EXCHANGE EQUIPMENT
- MEASUREMENT EQUIPMENT
- FA/OA EQUIPMENT

ELECTRICAL CHARACTERISTICS (TA = 25 °C)

PART NUMBER			PS7341-1A, PS7341L-1A			
	SYMBOLS	PARAMETERS	UNITS	MIN	TYP	MAX
Diode	VF	Forward Voltage, IF = 10 mA	V		1.2	1.4
	IR	Reverse Current, VR = 5 V	μA			5.0
MOS FET	ILOFF	Off-State Leakage Current, VD = 400 V	μA		0.03	1.0
	COUT	Output Capacitance, V = 0 V, f = 1 MHz	pF		65	
Coupled	IFON	LED On-state Current, IL = 150 mA	mA			2.0
	RON1	On-State Resistance, IF = 10 mA, IL = 10 mA	Ω		20	30
	RON2	On-State Resistance, IF = 10 mA, IL = 150 mA, t ≤ 10 ms	Ω		16	25
	ton	Turn-on Time ¹ IF = 10 mA, VO = 5 V, PW ≤ 10 ms	ms		0.35	1.0
	toff	Turn-off Time ¹ IF = 10 mA, VO = 5 V, PW ≥ 10 ms	ms		0.03	0.2
	Ri-o	Isolation Resistance, Vi-o = 1.0 kVdc	Ω	10 ⁹		
	Ci-o	Isolation Capacitance, V = 0 V, f = 1 MHz	pF		1.1	

Notes:

1. Turn-on, Turn-off Time.

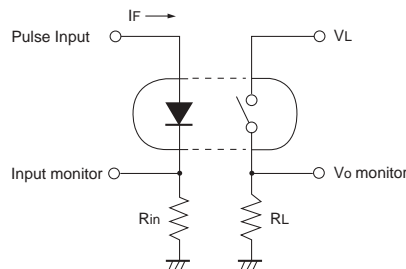
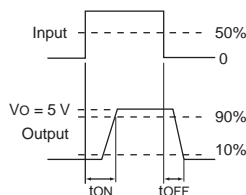

PS7341-1A, PS7341L-1A

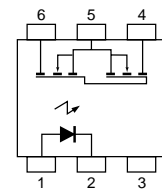

PS7341-1A, PS7341L-1A

ABSOLUTE MAXIMUM RATINGS¹ (T_A = 25°C)

SYMBOLS	PARAMETERS	UNITS	RATINGS
Diode			
I _F	Forward Current (DC)	mA	50
V _R	Reverse Voltage	V	5.0
P _D	Power Dissipation	mW	50
I _{FP}	Peak Forward Current ²	A	1
MOSFET			
V _L	Break Down Voltage	V	400
I _L	Continuous Load Current ³	Conn. (A)	mA
		Conn. (B)	mA
		Conn. (C)	mA
I _{LP}	Pulse Load Current ⁴ AC/DC	mA	240
P _D	Power Dissipation	mW	560
COUPLED			
B _V	Isolation Voltage ⁵	Vr.m.s.	3750
P _T	Total Power Dissipation	mW	610
T _A	Operating Ambient Temp.	°C	-40 to +85
T _{STG}	Storage Temperature	°C	-40 to +125

Notes:

- Operation in excess of any one of these parameters may result in permanent damage.
- PW = 100 μs, Duty Cycle = 1 %
- Conditions : I_F ≥ 2 mA. The following types of load connections are available.

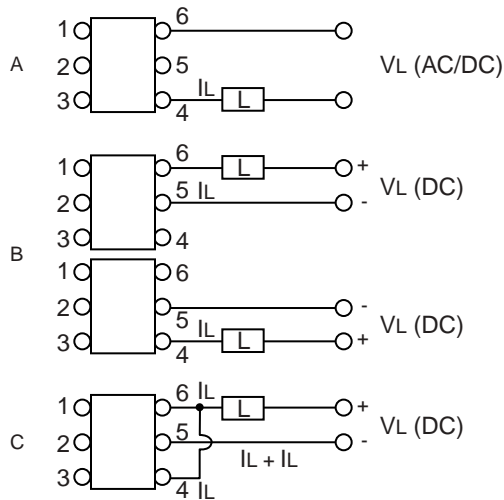

- PW = 100 ms, 1 shot
- AC voltage for 1 minute at T_A = 25 °C, RH = 60 % between input and output.

RECOMMENDED OPERATING CONDITIONS (T_A = 25°C)

PART NUMBER		PS7341-1A, PS7341L-1A			
SYMBOLS	PARAMETERS	UNITS	MIN	TYP	MAX
I _F	LED Operating Current	mA	2	10	20
V _F	LED Off Voltage	V	0		0.5

OUTLINE DIMENSIONS (Units in mm)

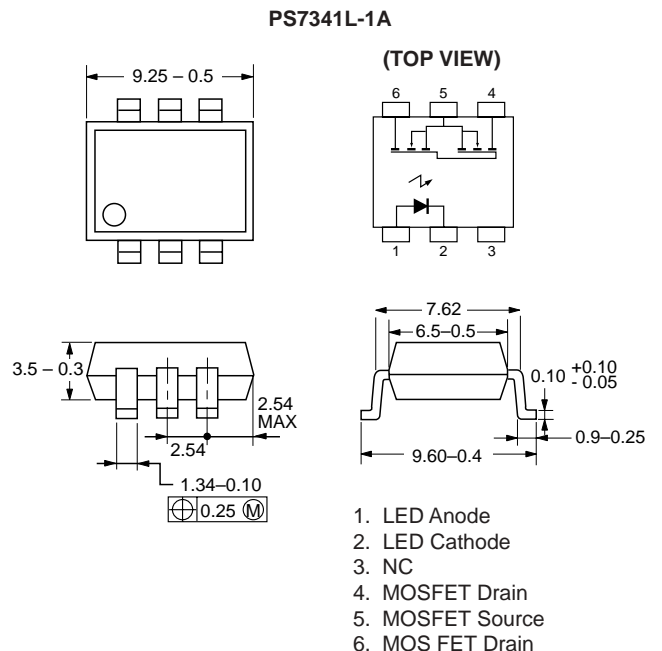
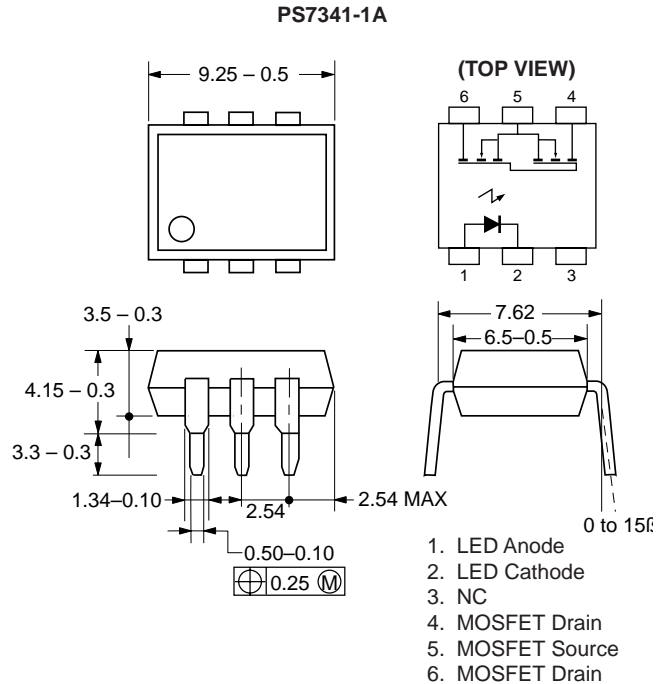

TYPICAL PERFORMANCE CURVES ($T_A = 25\text{ }^\circ\text{C}$)

MAXIMUM FORWARD CURRENT vs. AMBIENT TEMPERATURE

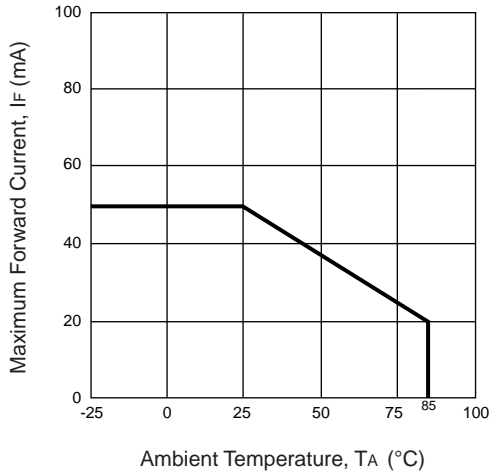

MAXIMUM LOAD CURRENT vs. AMBIENT TEMPERATURE

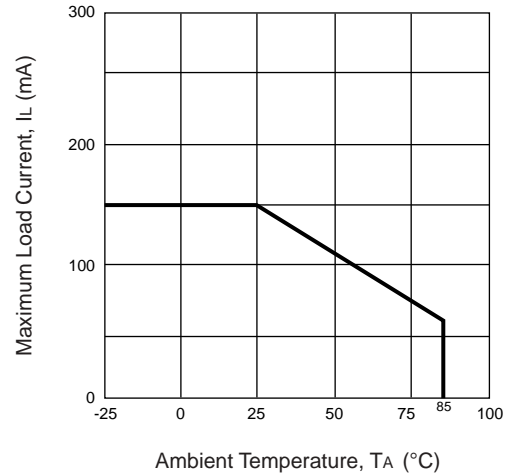

FORWARD VOLTAGE vs. AMBIENT TEMPERATURE

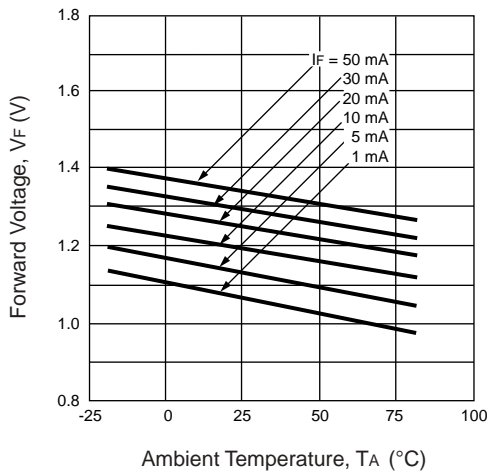

OUTPUT CAPACITANCE vs. SUPPLY VOLTAGE

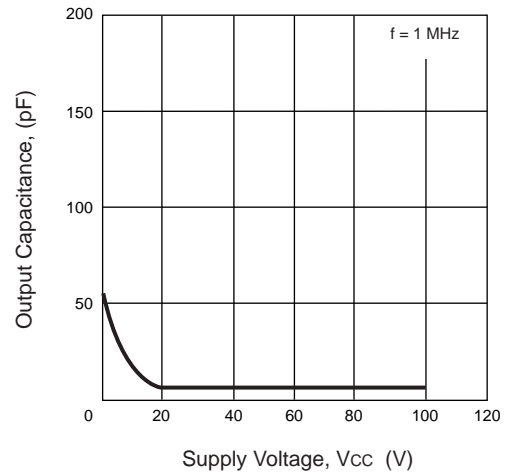

OFF-STATE LEAKAGE CURRENT vs. SUPPLY VOLTAGE

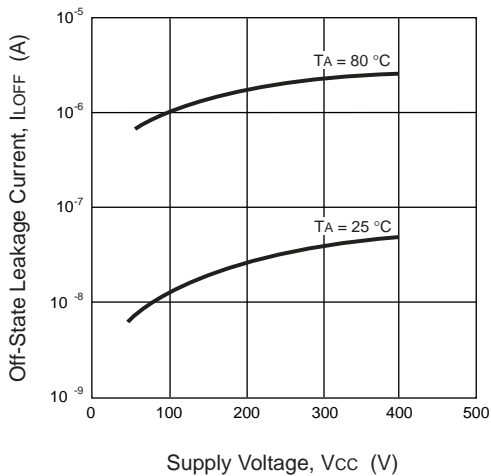

LOAD CURRENT vs. LOAD VOLTAGE

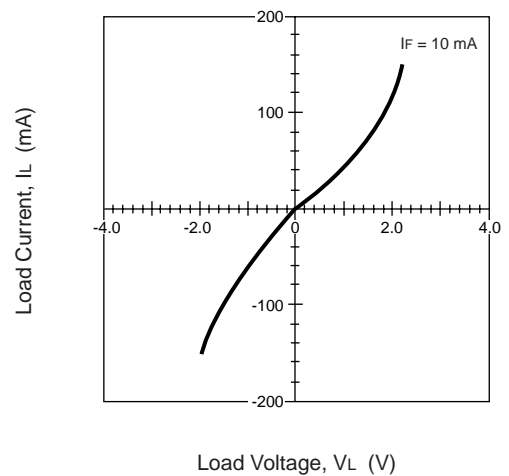

TYPICAL PERFORMANCE CURVES (TA = 25 °C)

NORMALIZED ON-STATE RESISTANCE vs. AMBIENT TEMPERATURE

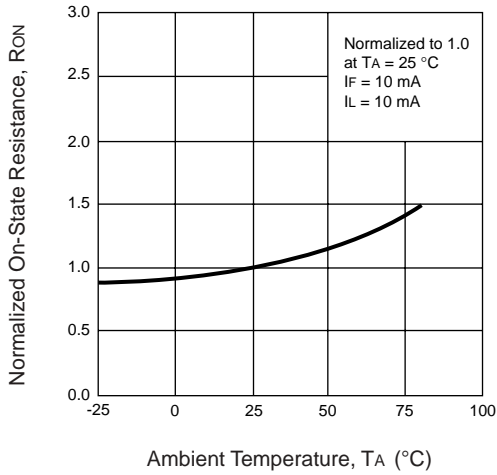

ON-STATE DISTRIBUTION

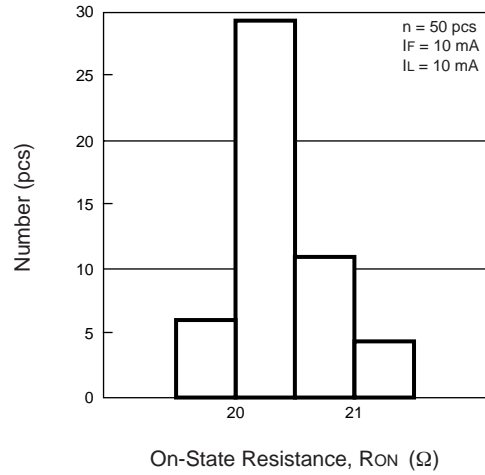

TURN-ON TIME vs. FORWARD CURRENT

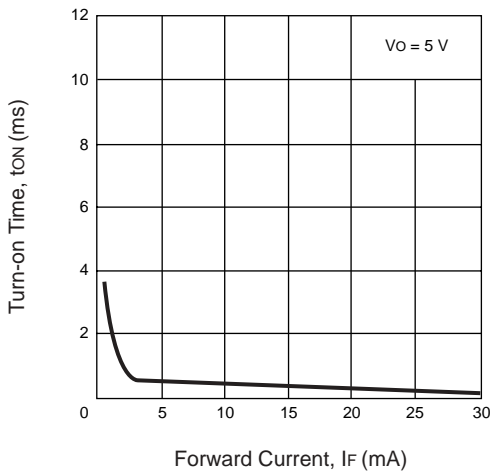

TURN-OFF TIME vs. FORWARD CURRENT

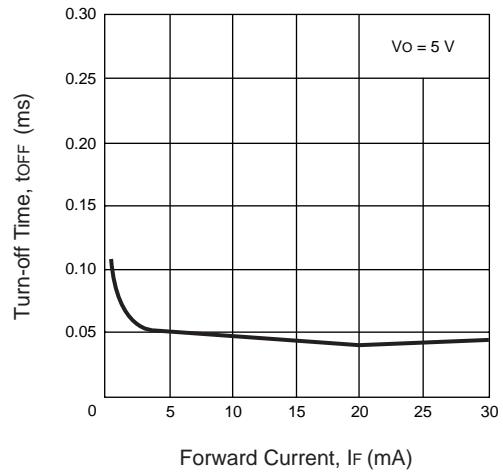

TURN-ON TIME DISTRIBUTION

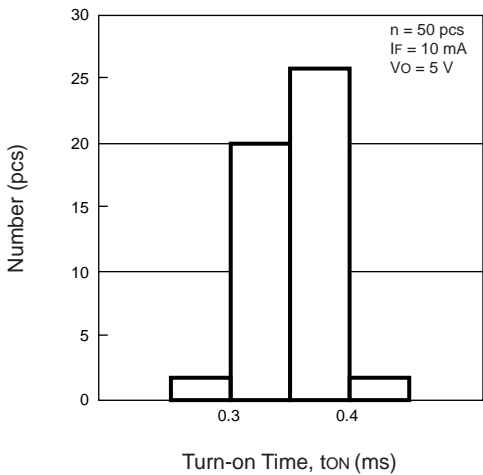

TURN-OFF TIME DISTRIBUTION

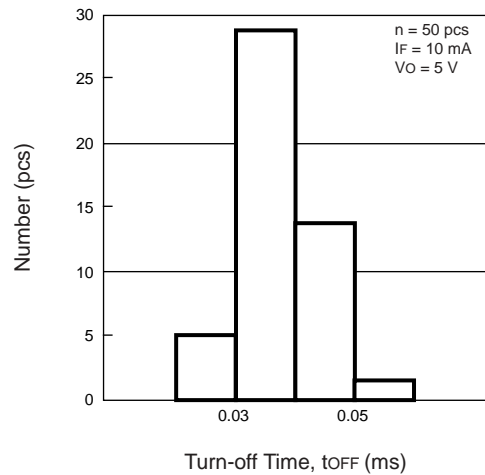

TYPICAL PERFORMANCE CURVES ($T_A = 25\text{ }^\circ\text{C}$)

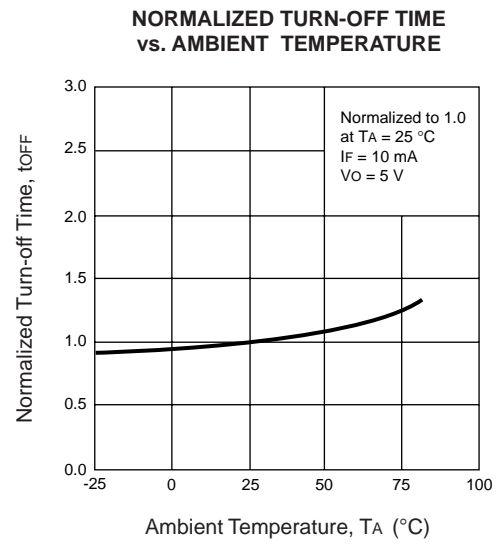
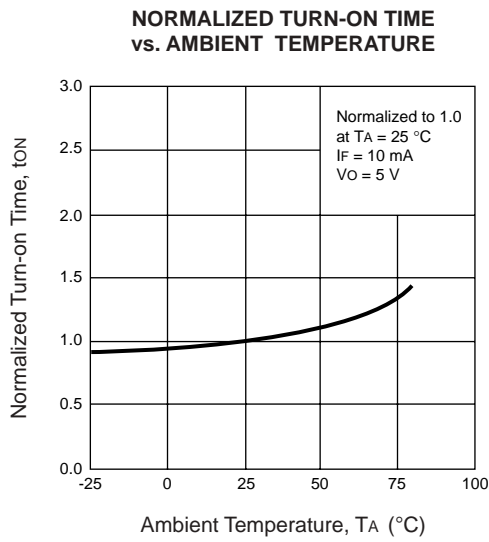

TAPING SPECIFICATIONS (Units in mm)

OUTLINE AND DIMENSIONS (TAPE)

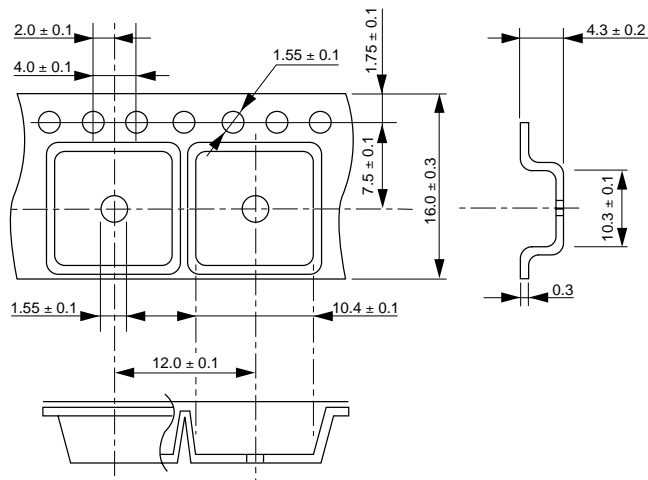

OUTLINE AND DIMENSIONS (REEL)

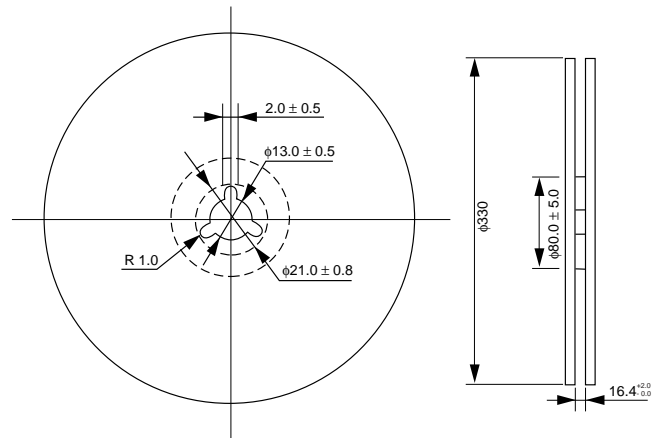

Notes:
1. Packaging : 1000 pcs/reel

TAPING DIRECTION

PS7341L-1A-E3

PS7341L-1A-E4

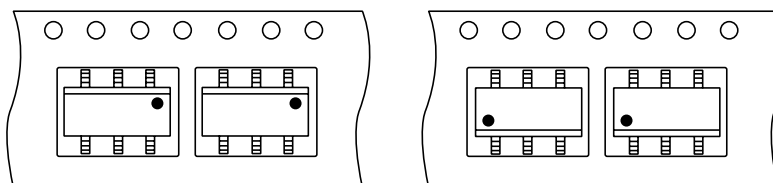

RECOMMENDED SOLDERING CONDITIONS

(1) Infrared reflow soldering

- **Peak reflow temperature**
235 °C (package surface temperature)
- **Time of temperature higher than 210 °C**
30 seconds or less
- **Number of reflows**
One
- **Flux**
Rosin flux containing small amount of chlorine (The flux with a max. chlorine content of 0.2 Wt % is recommended)

Recommended Temperature Profile of Infrared Reflow

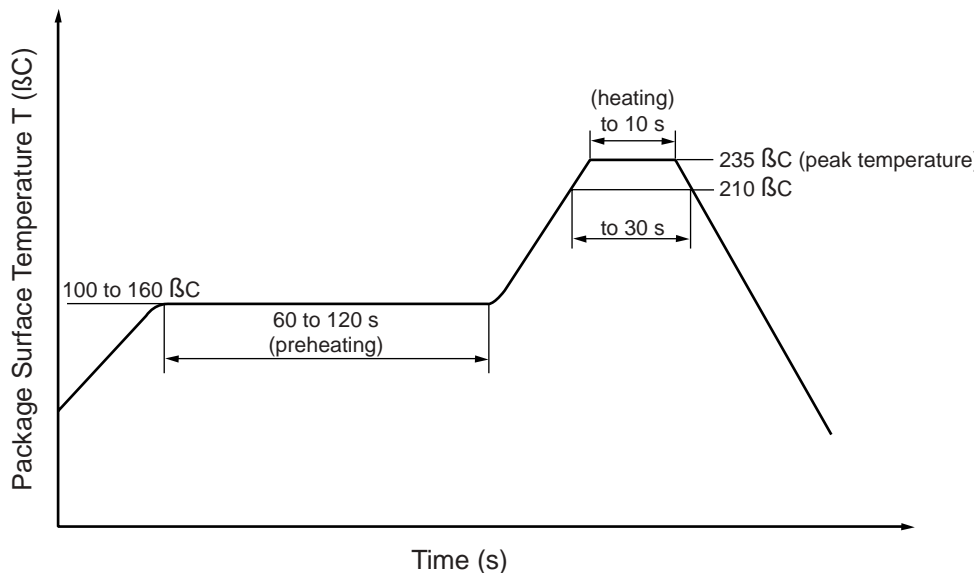

(2) Dip soldering

- **Temperature**
260 °C or below (molten solder temperature)
- **Time**
10 seconds or less
- **Number of times**
One
- **Flux**
Rosin flux containing small amount of chlorine (The flux with a max. chlorine content of 0.2 Wt % is recommended.)

(3) Cautions

- **Fluxes**
Avoid removing the residual flux with freon-based and chlorine-based cleaning solvent.

After opening the dry pack, solder the products within the valid storage period specified on the label on the dry pack.

EXCLUSIVE NORTH AMERICAN AGENT FOR **NEC** RF, MICROWAVE & OPTOELECTRONIC SEMICONDUCTORS

CEL CALIFORNIA EASTERN LABORATORIES • Headquarters • 4590 Patrick Henry Drive • Santa Clara, CA 95054-1817 • (408) 988-3500 • Telex 34-6393 • FAX (408) 988-0279
24-Hour Fax-On-Demand: 800-390-3232 (U.S. and Canada only) • Internet: <http://WWW.CEL.COM>

DATA SUBJECT TO CHANGE WITHOUT NOTICE

08/06/2001