

FEATURES

- **CONTAINS A CURRENT LIMIT FUNCTION:**
(ILMT = 125 to 250 mA)
- **DESIGNED FOR AC/DC SWITCHING APPLICATIONS**
- **DOUBLE MOLDED STRUCTURE:**
(Isolation Voltage \geq 3.75 kVac)
- **IDEAL FOR ANALOG SIGNAL CONTROL APPLICATIONS**
- **SMALL PACKAGE TYPE:**
6 Pin DIP
- **LOW OFFSET VOLTAGE**
- **LOW LED OPERATING CURRENT:**
IF = 2 mA
- **SURFACE MOUNT AVAILABLE**

DESCRIPTION

PS7341C-1A and PS7341CL-1A are solid state relays containing GaAs LEDs on the light emitting side (input side) and MOSFETs including a current control circuit on the output side. The current control circuit of the OCMOS FET protects this device from thermal breakdown and output circuit. These devices are suitable for analog signal control because of their low offset and high linearity.

APPLICATIONS

- EXCHANGE EQUIPMENT
- MEASUREMENT EQUIPMENT
- FA/OA EQUIPMENT

ELECTRICAL CHARACTERISTICS (TA = 25°C)

PART NUMBER			PS7341C-1A, PS7341CL-1A		
SYMBOLS	PARAMETERS	UNITS	MIN	TYP	MAX
Diode	V _F	Forward Voltage, I _F = 10 mA	V	1.2	1.4
	I _R	Reverse Current, V _R = 5 V	μ A		5.0
MOSFET	I _{Loff}	Off-State Leakage Current, V _D = 400 V	μ A	.001	1.0
	C _{out}	Output Capacitance, V _D = 0 V, f = 1 MHz	pF	63	
Coupled	I _{Fon}	LED On-state Current, I _L = 120 mA	mA		2.0
	R _{on1}	On-State Resistance, I _F = 10 mA, I _L = 10 mA	Ω	27	35
	R _{on2}	On-State Resistance, I _F = 10 mA, I _L = 120 mA	Ω	22	30
	t _{on}	Turn-On Time ¹ I _F = 10 mA, V _L = 5 V, R _L = 500 Ω PW \geq 10 ms	ms	0.55	1.0
	t _{off}		ms	0.07	1.0
	R _{I-O}	Isolation Resistance, V _{in-out} = 1.0 kVdc	Ω	10 ⁹	
	C _{I-O}	Isolation Capacitance, V = 0 V, f = 1 MHz	pF		1.1
ILMT ²	Limit Current, I _F = 10 mA, t = 5 ms, V _L = 6 V	mA	125	200	250

Notes:

1. Test Circuit for Switching Time:

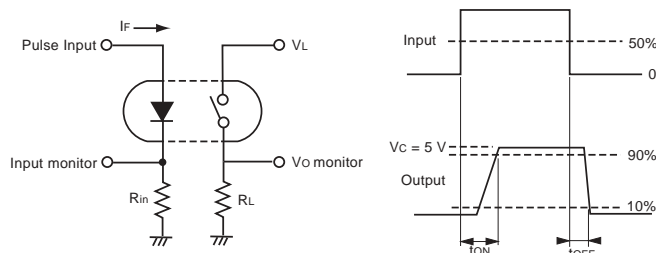

2. N rank : 125 to 250 mA
M rank : 125 to 180 mA
L rank : 170 to 250 mA

PS7341C-1A, PS7341CL-1A

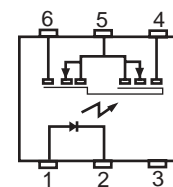

ABSOLUTE MAXIMUM RATINGS¹ (T_A = 25°C)

SYMBOLS	PARAMETERS	UNITS	RATINGS
			PS7341C-1A PS7341CL-1A
Diode			
V _R	Reverse Voltage	V	5
I _F	Forward Current (DC)	mA	50
P _D	Power Dissipation	mW	50
I _{F (Peak)}	Peak Forward Current ²	A	1
MOSFET			
V _L	Break Down Voltage	V	400
I _L	Continuous Load Current ³	mA	120
	Connection A		
	Connection B Connection C		
ILP	Pulse Load Current ⁴ (AC/DC Connection)	mA	120
P _D	Power Dissipation	mW	560
Coupled			
BV	Isolation Voltage ⁵	V	3,750
P _T	Total Power Dissipation	mW	610
T _{STG}	Storage Temperature	°C	-40 to +125
T _A	Operating Ambient Temp.	°C	-40 to +85

Notes:

1. Operation in excess of any one of these parameters may result in permanent damage.
2. PW = 100 μs, Duty Cycle = 1 %
3. Conditions: I_F ≥ 2 m. The following types of load connections are available.

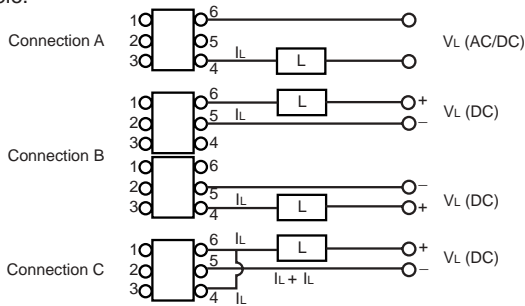

4. PW = 100 ms, 1 shot.
5. AC voltage for 1 minute at T_A = 25 °C, RH = 60 % between input and output.

RECOMMENDED OPERATING CONDITIONS (T_A = 25 °C)

SYMBOL	PARAMETER	UNITS	MIN	TYP	MAX
I _F	LED Operating Current	mA	2	10	20
V _F	LED Off Voltage	V	0		0.5

ORDERING INFORMATION

PART NUMBER	PACKAGE	PACKING STYLE
PS7341C-1A	6 pin DIP	Magazine case 50 pcs
PS7341CL-1A		
PS7341CL-1A-E3		Embossed Tape 1000 pcs/reel
PS7341CL-1A-E4		

OUTLINE DIMENSIONS (Units in mm)

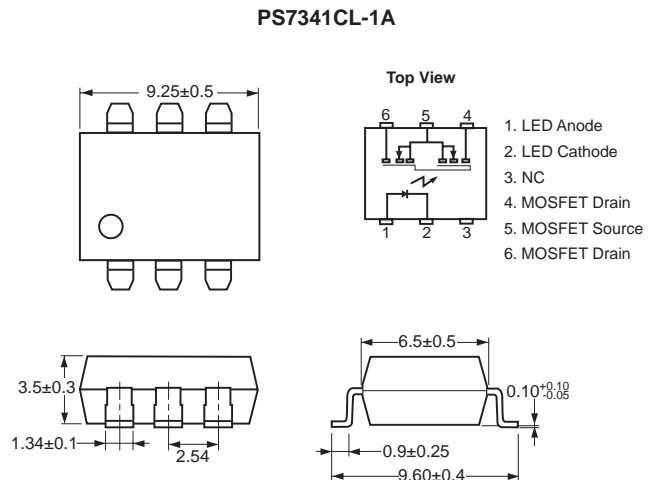
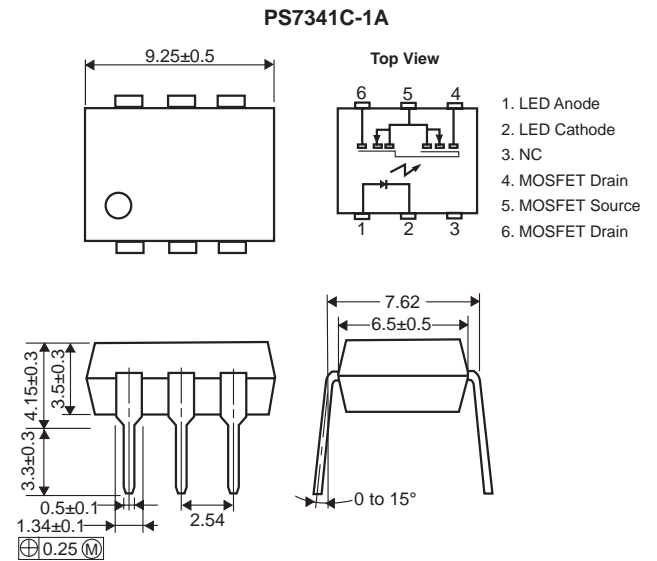

TYPICAL PERFORMANCE CURVES (T_A = 25 °C)

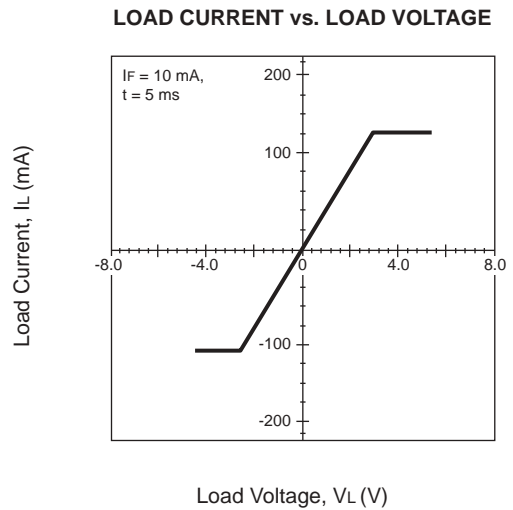
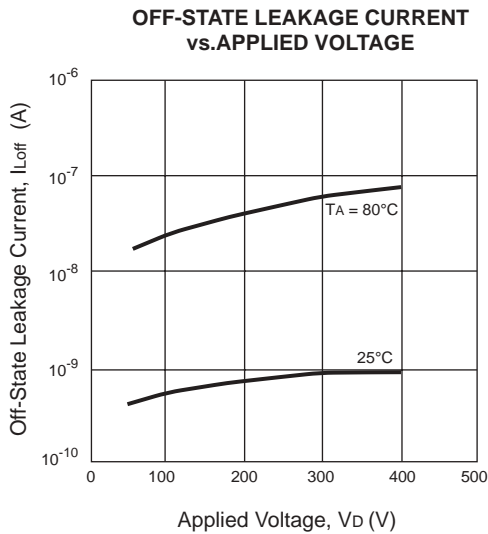
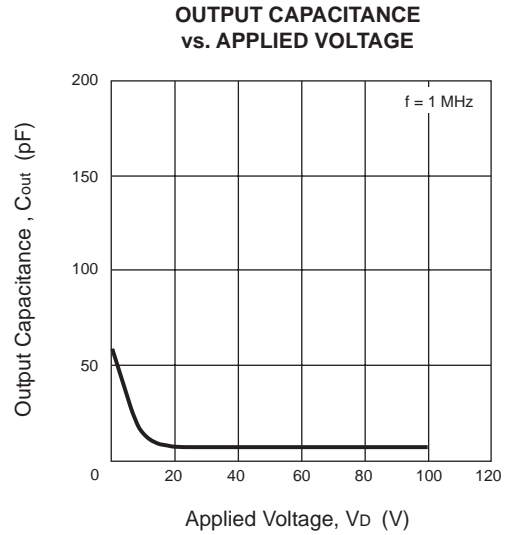
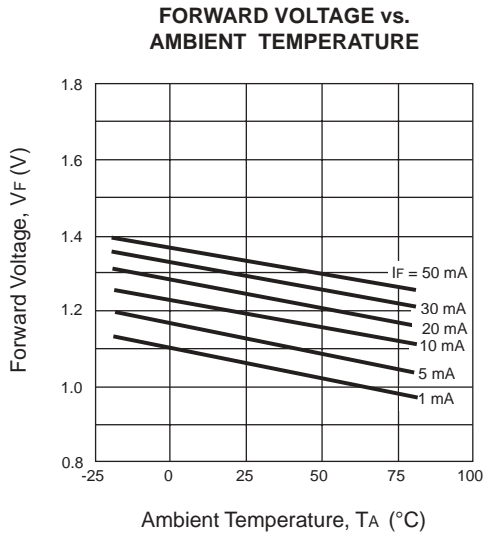
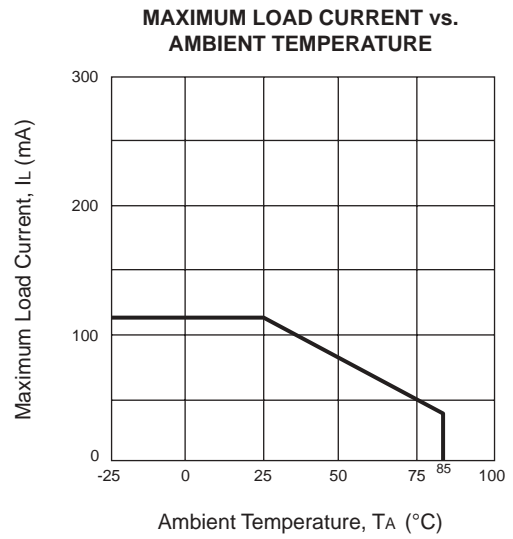
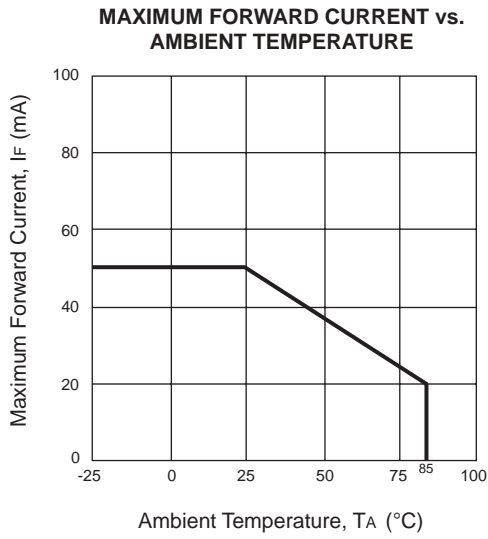

TYPICAL PERFORMANCE CURVES ($T_A = 25^\circ\text{C}$)

NORMALIZED ON-STATE RESISTANCE vs. AMBIENT TEMPERATURE

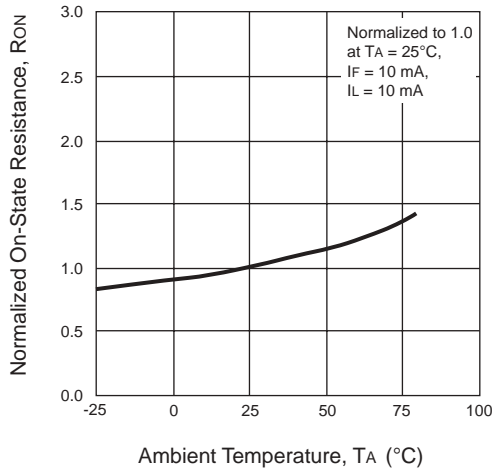

ON-STATE RESISTANCE DISTRIBUTION

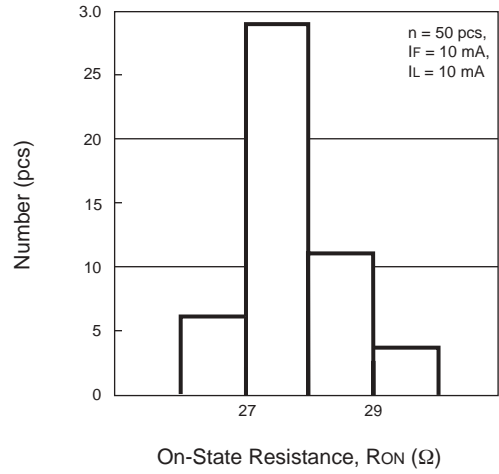

TURN-ON TIME vs. FORWARD CURRENT

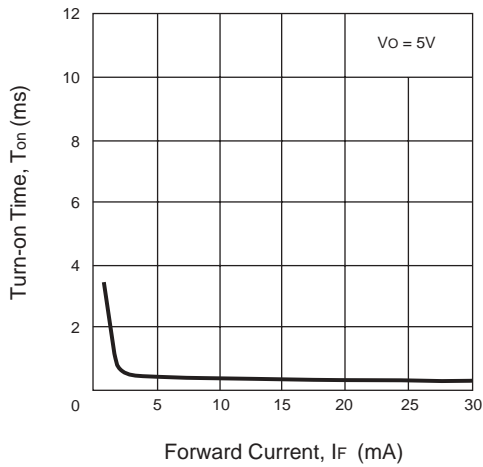

TURN-OFF TIME vs. FORWARD CURRENT

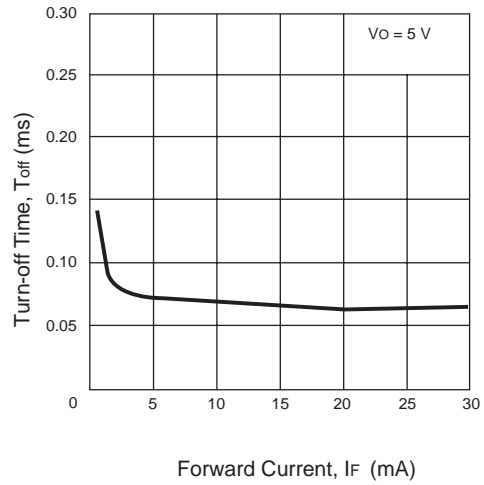

TURN-ON TIME DISTRIBUTION

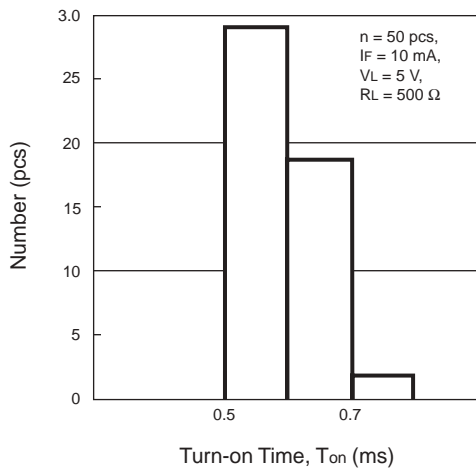

TURN-OFF TIME DISTRIBUTION

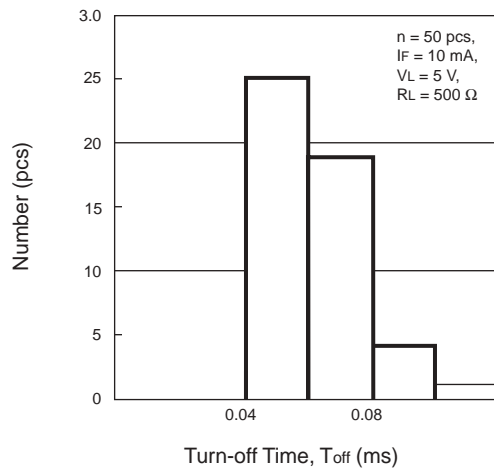

TYPICAL PERFORMANCE CURVES (TA = 25 °C)

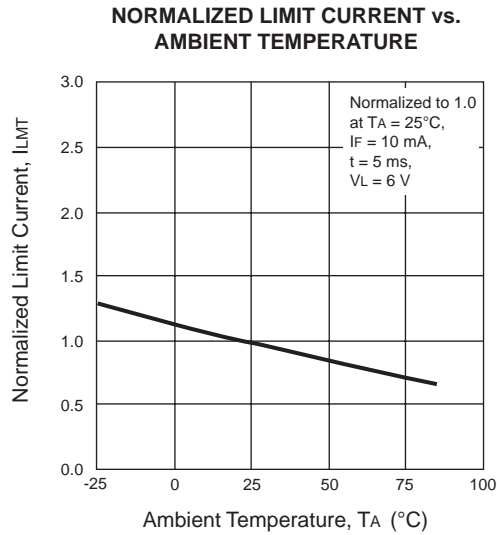
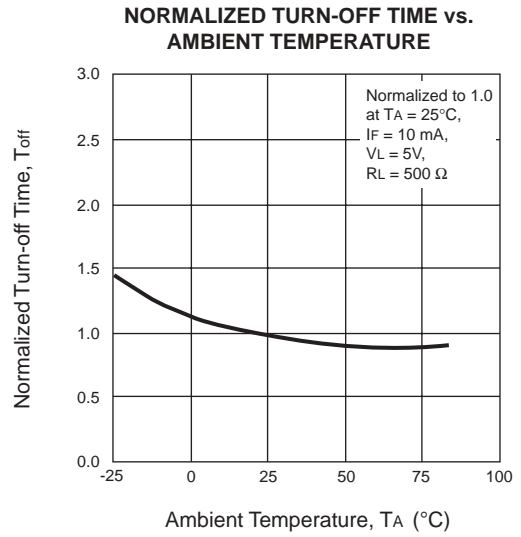
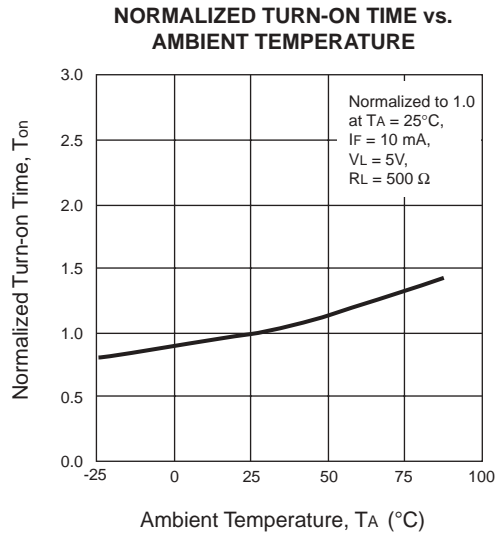

TAPING SPECIFICATIONS (Units in mm)

OUTLINE AND DIMENSIONS (TAPE)

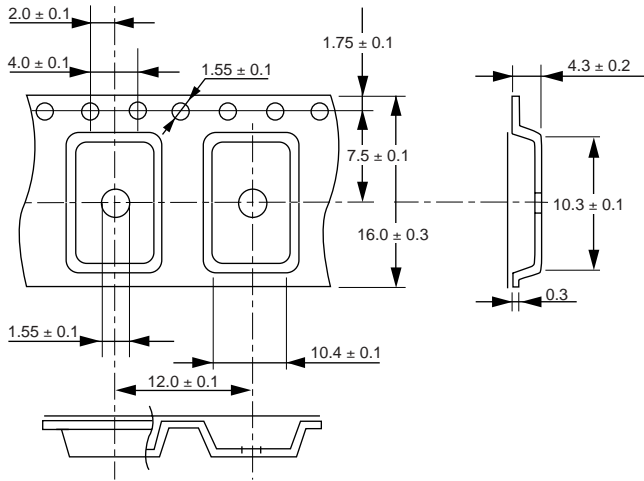

OUTLINE AND DIMENSIONS (REEL)

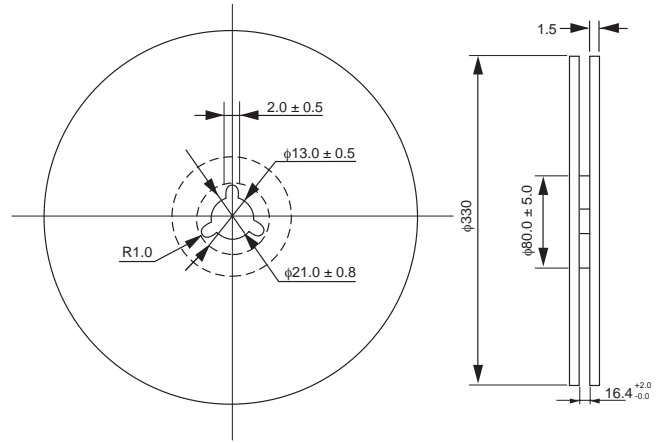

Notes:
1. Packing : 1000 pcs/reel

TAPE DIRECTION

PS7341CL-1A-E3

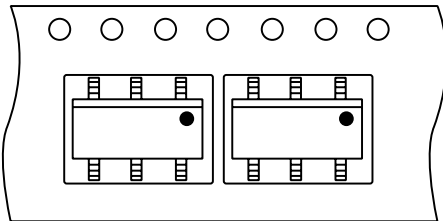

PS7341CL-1A-E4

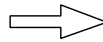
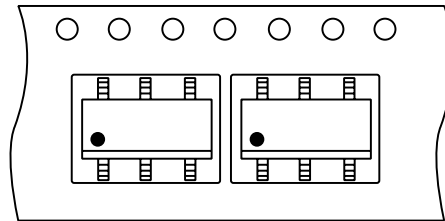

RECOMMENDED SOLDERING CONDITIONS

(1) Infrared reflow soldering

- **Peak reflow temperature**
235 °C (package surface temperature)
- **Time of temperature higher than 210 °C**
30 seconds or less
- **Number of reflows**
One
- **Flux**
Rosin flux containing small amount of chlorine (The flux with a maximum chlorine content of 0.2 Wt % is recommended).

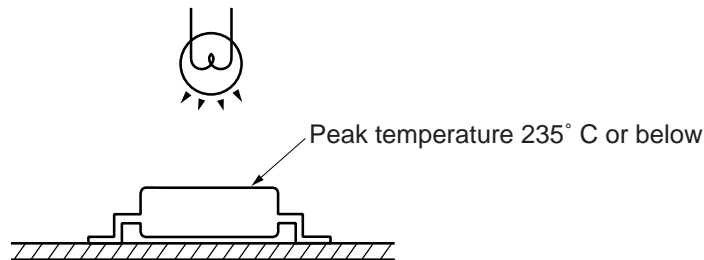
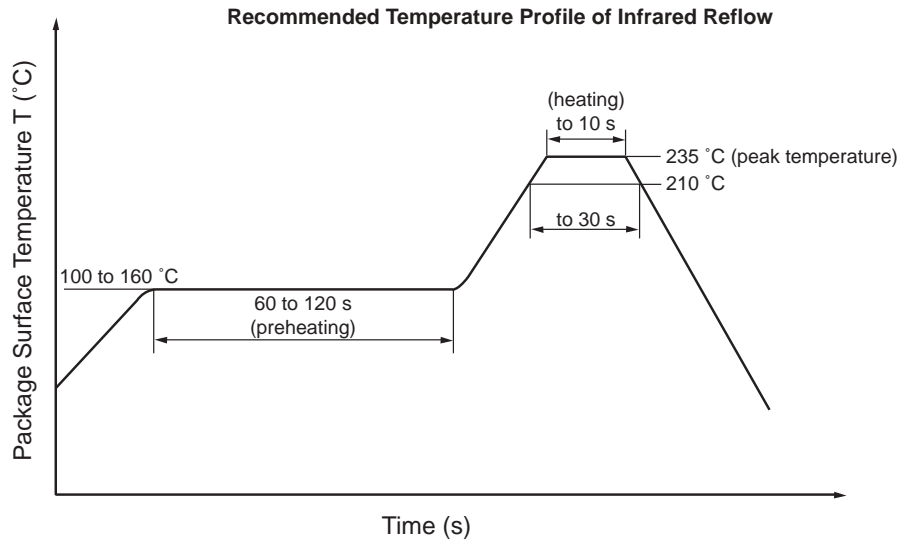

(2) Dip soldering

- **Temperature**
260 °C or below (molten solder temperature)
- **Time**
10 seconds or less
- **Number of times**
One
- **Flux**
Rosin flux containing small amount of chlorine (The flux with a maximum chlorine content of 0.2 Wt % is recommended).

(3) Cautions

- **Fluxes**
Avoid removing the residual flux with freon-based and chlorine-based cleaning solvent.
- **Products in a dry pack**
After opening the dry pack, solder the products within the valid storage period specified on the label on the dry pack.