



PRELIMINARY SPECIFICATION

BIPOLAR ANALOG INTEGRATED CIRCUIT

μ PC1401C

NTSC CHROMINANCE, LUMINANCE, SYNCHRONIZATION, AND DEFLECTION CIRCUIT (CRYSTAL OSCILLATOR TYPE)

μ PC1401C is a bipolar analog integrated circuit designed for NTSC color TV.

It contains video signal processing circuit, chroma signal demodulation circuit, synchronous signal separator, deflection signal – horizontal and vertical – generator and the peripheral circuits in a plastic molded 42 pins dual in-line package.

It makes such adjustments as chroma phase controller, "HORIZONTAL HOLD" and "VERTICAL HOLD" unnecessary.

So, number of components and adjustment man-hour are reduced remarkably.

FEATURES

- Chroma sub-carrier regenerator works using a crystal resonator.
- Deflection original clock signal is generated using a ceramic resonator.
- All of user controls are controlled with DC voltage externally.
- Chroma difference signal output, and built-in Y (intensity of brightness) signal power stage.
- Clear view by the built-in aperture correction circuit.
- Freely programable video DC restration externally.

PACKAGE DIMENSIONS Unit : in millimeters (inches)

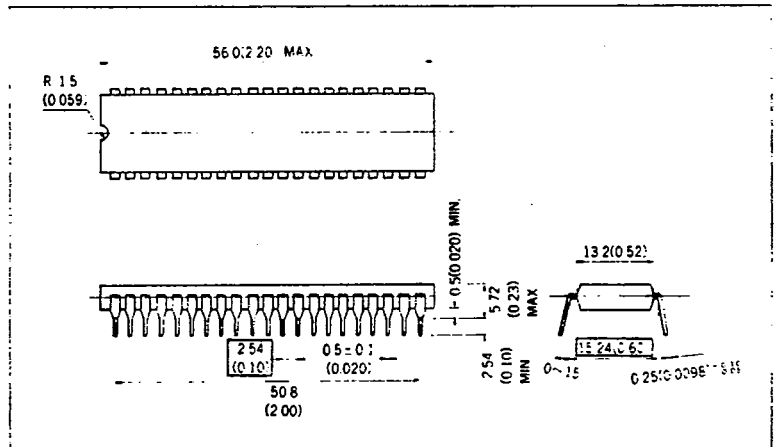

BLOCK DIAGRAM

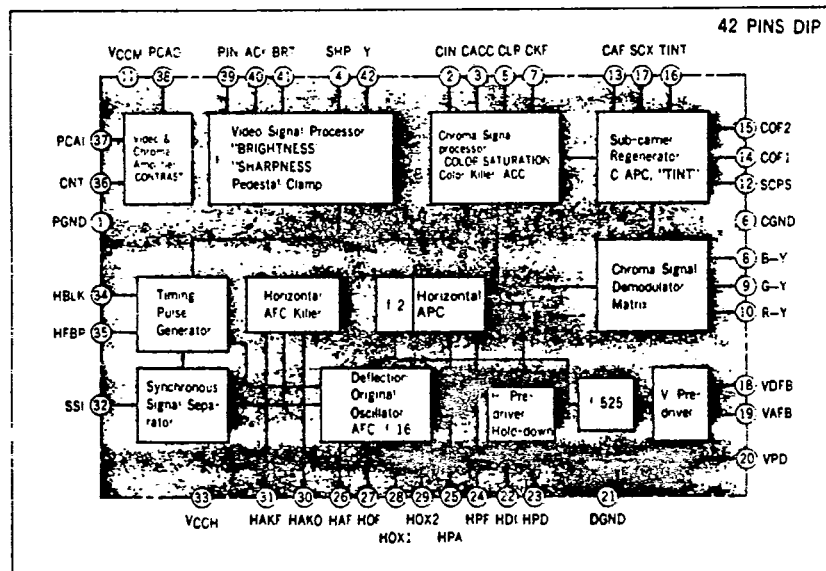

μPC1401C

TV BLOCK DIAGRAM

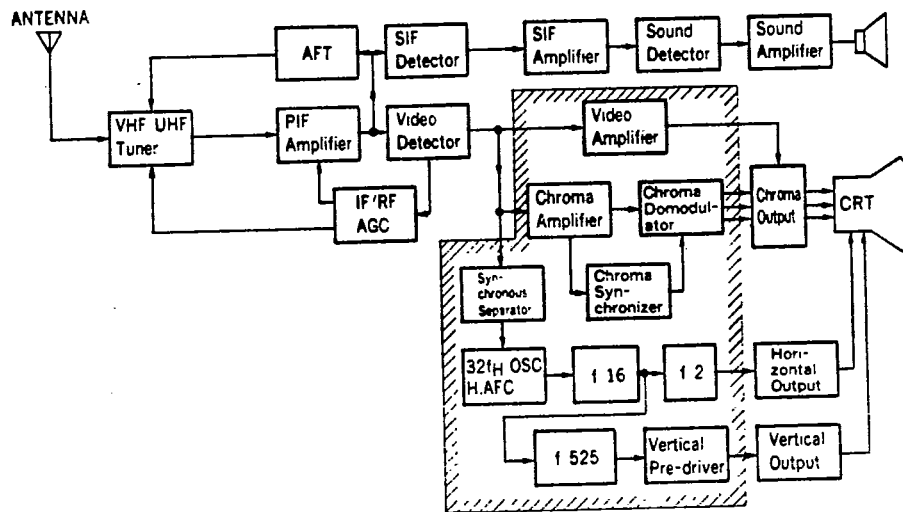

CONNECTION DIAGRAM (Top View)

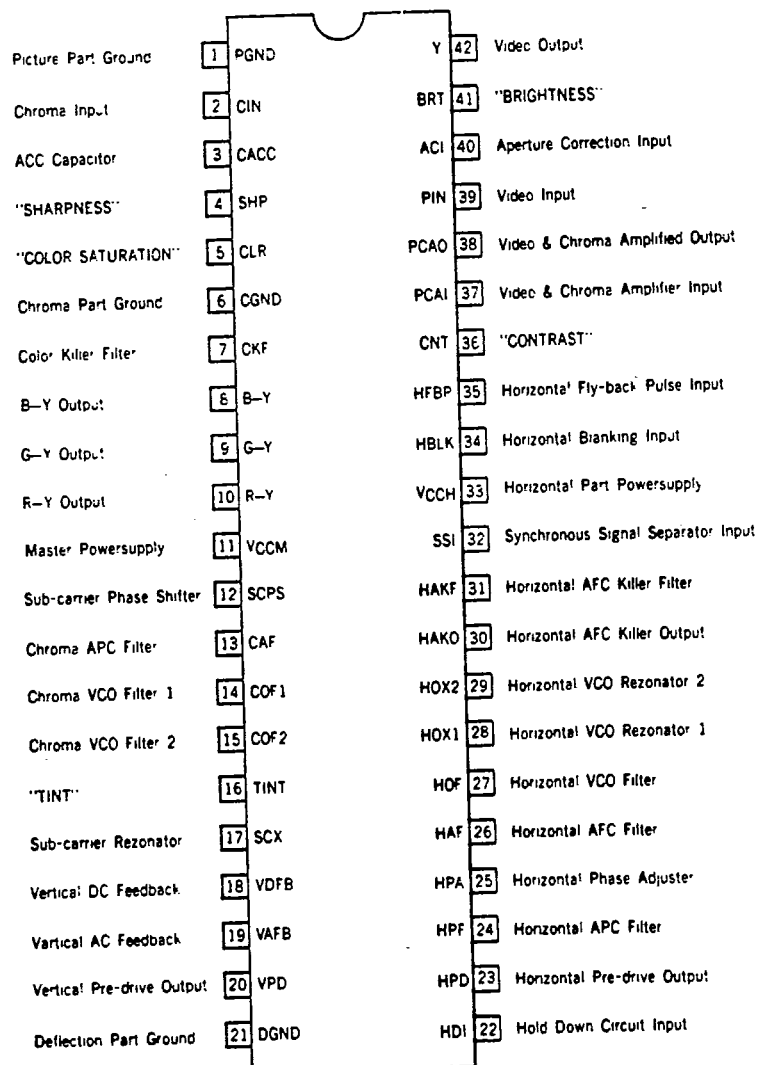

ABSOLUTE MAXIMUM RATINGS ($T_a=25^\circ\text{C}$)

Master Powersupply Voltage	V_{CCM}	13.5	V
Horizontal Powersupply Voltage	V_{CCH}	13.5	V
V & C Amplifier Input Voltage	V_{PCAI}	5.0	V
Chroma Input Voltage	V_{CIN}	5.0	V
Synch. Separator Input Voltage	V_{SSI}	5.0	V
H. Flyback Pulse Input Voltage	V_{HFBP}	V_{CCH}	V
H. Blanking Pulse Input Voltage	V_{HBLK}	V_{CCH}	V
Video Output Current	I_Y	50 ($V_Y < 5.0\text{ V}$)	mA
B-Y, G-Y, R-Y Output Current	$I_{B-Y}, I_{G-Y}, I_{R-Y}$	-10	mA
H. Pre-driver Output Current	I_{HPD}	± 10	mA
V. Pre-driver Output Current	I_{VPD}	-10	mA
Total Power Dissipation	P_D	1.4 ($T_a=60^\circ\text{C}$)	W
Operating Temperature	T_{opt}	-10 to +60	$^\circ\text{C}$
Storage Temperature	T_{stg}	-40 to +150	$^\circ\text{C}$

Mark "-" of current means flow out from the terminal.

RECOMMENDED OPERATING CONDITIONS ($T_a=25^\circ\text{C}$)

Master Power-supply Voltage	V_{CCM}	12 ± 1	V
Horizontal Power-supply Voltage	V_{CCH}	12 ± 1	V
V & C Input Signal Level	e_{PCAI}	1	V_{p-p}
Chroma Input Signal Level	e_{CIN}	200 (Burst Signal)	mV_{p-p}
H. Blanking Pulse Input Voltage	e_{HBLK}	More than 7	V_{p-p}
H. Flyback Pulse Input Voltage	e_{HFBP}	More than 7	V_{p-p}
Video Output Voltage	E_Y	6 (Pedestal Level)	V
"CONTRAST" Control Voltage	V_{CNT}	0 to (4 to 5) to V_{CCM}	V
"BRIGHTNESS" Control Voltage	V_{BRT}	0 to (8 to 9) to V_{CCM}	V
"SHARPNESS" Control Voltage	V_{SHP}	0 to (4 to 5) to V_{CCM}	V
"COLOR SATURATION" Control Voltage	V_{CLR}	V_{CCM} to (5 to 4) to 0	V
"TINT" Control Voltage	V_{TINT}	0 to (4 to 5) to V_{CCM}	V
Hold-down Circuit Input Voltage	V_{HDI}	Trigger level is 0.7	V
H. Pre-driver Output Current	I_{HPD}	± 2	mA

μ PC1401C

NEC ELECTRON DEVICE

ELECTRICAL CHARACTERISTICS ($T_s=25^\circ\text{C}$)

Video & Chroma Part

CHARACTERISTICS	SYMBOL	MIN.	TYP.	MAX.	UNIT	CONDITIONS
Master Powersupply Current	I_{CCM}	42	55	75	mA	$V_{CCM} (=V_{CCH})=12\text{ V}$
B-Y Output Stability Depend On ACC -1	ACC1	-3	0	+3	dB	Burst level at CIN changes from 0 dB (200 mV _{p-p}) to +6 dB (400 mV _{p-p}).
B-Y Output Stability Depend On ACC -2	ACC2	-7	-3	+2	dB	Burst level at CIN changes from 0 dB (200 mV _{p-p}) to -20 dB (20 mV _{p-p}).
Maximum Burst Signal Level Suppressed by Color Killer Function	e_K		-40		dB	0 dB = 200 mV _{p-p} .
Remaining B-Y Signal Under Suppression of Color Killer Function	$e_{B-Y(K)}$			50	mV _{p-p}	Remaining B-Y signal level when burst signal is applied to CIN at e_K level.
Remaining B-Y Signal At Minimum Of "COLOR SATURATION"	$e_{B-Y(CLR)}$			20	mV _{p-p}	Remaining B-Y signal level when CLR voltage is 9 V.
B-Y Signal Distribution In Standard Condition	$e_{B-Y(SC)}$	1.5	2.5	3.6	V _{p-p}	Burst level at CIN is 200 mV _{p-p} . CLR voltage is 7.1 V.
Maximum B-Y Signal Level	$e_{B-Y(MAX)}$	5.0	5.8		V _{p-p}	Burst level at CIN is 200 mV _{p-p} . CLR voltage is 0 V.
Variable Range of B-Y Signal Phase Depend On "TINT" Control Function	$\Delta\theta_{B-Y}$	80	90		deg.	TINT voltage changes from 0 V to V_{CCM} .
B-Y Signal Distribution At Standard "CONTRAST" Control Voltage	$e_{B-Y(CNT)}$	1.4	2.0	2.4	V _{p-p}	Burst level at CIN is 200 mV _{p-p} . Adjust B-Y signal level to 2.5 V _{p-p} with "COLOR SATURATION" control function when CNT voltage is 9V. After it, set CNT voltage to 4.7 V.
Variable Range of B-Y Signal Level Depend On "CONTRAST" Control Function	$\Delta e_{B-Y(CNT)}$	10.5	11.5	12.5	dB	Burst level at CIN is 200 mV _{p-p} . Adjust B-Y signal level to 2.5 V _{p-p} with "CONTRAST" control function when CNT voltage is 9 V. After it, set CNT voltage to 0 V.
Variable Frequency Range of Regenerated Sub-carrier -1	f_{SC1}	400	580	750	kHz	Frequency aberration of SCPS signal from 3 579.545 kHz. CAF voltage is 4.5 V.
Variable Frequency Range of Regenerated Sub-carrier -2	f_{SC2}	-800	-1050	-1300	kHz	Frequency aberration of SCPS signal from 3 579.545 kHz. CAF voltage is 7.5 V.
Peak Voltage of CAF Signal Under Control Of Internal Automatic Sweep Function	V_{PCAF}	7.0	7.2	7.5	V	PCAI input is deflection synchronous signal only. The input level is 300 mV _{p-p} .
Bottom Voltage Of CAS Signal Under Control Of Internal Automatic Sweep Function	V_{BCAF}	4.3	4.6	4.8	V	PCAI input is deflection synchronous signal only. The input level is 300 mV _{p-p} .
Chroma Demodulator Output Ratio -1	R-Y/B-Y	0.68	0.75	0.82	V/V	R-Y level divided by B-Y. CIN input is 200 mV _{p-p} at the burst level, and 400 mV _{p-p} at the coloring ingredient. Frequency of the coloring ingredient is 3.63 MHz.
Chroma Demodulator Output Ratio -2	G-Y/B-Y	0.20	0.25	0.31	V/V	G-Y level divided by B-Y. CIN input is 200 mV _{p-p} at the burst level, and 400 mV _{p-p} at the coloring ingredient. Frequency of the coloring ingredient is 3.63 MHz.

CHARACTERISTICS	SYMBOL	MIN.	TYP.	MAX.	UNIT	CONDITIONS
R-Y Demodulation Angle	$\angle R-Y$	90	98	106	deg.	R-Y vector angle against B-Y vector. Burst level of CIN input is 200 mV _{p-p} .
G-Y Demodulation Angle	$\angle G-Y$	230	240	250	deg.	G-Y vector angle against B-Y vector. Burst level of CIN input is 200 mV _{p-p} .
Demodulator Output DC Voltage Distribution	E_o	6.6	7.1	7.6	V	DC voltage of B-Y, G-Y, and R-Y, when no input to CIN.
Temperature Coefficient Of E_o	$\Delta E_o(T_a)$		0	± 2	mV/ $^{\circ}$ C	Ambient Temperature changes from -10° C to $+60^{\circ}$ C
Non-uniformity of E_o	dE_o		0	± 200	mV	DC voltage difference among B-Y, G-Y, and R-Y, at tracing time.
Supply Voltage Dependence of dE_o	$\Delta dE_o(V_{CCM})$		0	50	mV	V_{CCM} changes from 11 V to 13 V. $V_{CCH}=V_{CCM}$
Temperature Coefficient of dE_o	$\Delta dE_o(T_a)$		0	+1	mV/ $^{\circ}$ C	Ambient Temperature changes from -10° C to $+60^{\circ}$ C
Remaining Carrier Wave Level Of Demodulator Output	e_{carry}		60	120	mV	Remaining sub-carrier wave level of B-Y, G-Y, and R-Y in tracing time (Contains harmonic over-tone ingredient), when no input to CIN.
Harmonic Over-tone Of Demodulator Output	e_{hot}		0.6	1.0	V _{p-p}	Harmonic over-tone level of B-Y, G-Y, and R-Y (Contains remaining sub-carrier) Burst signal level of CIN input is 200 mV _{p-p} .
Maximum Voltage Gain Of Video & Chroma Amplifier	A_{PCA}	6.0	7.0	9.0	dB	PCAO signal level comparing with PCAI Input. The PCAI input is shown by Fig. 2 in page 8. CNT voltage is 9 V.
PCAO Signal Distribution At Standard "CONTRAST" Control Voltage	$e_{PCAO}(CNT)$	1.3	1.8	2.3	V _{p-p}	PCAO output level, when CNT voltage is 4.7 V. PCAI Input is shown by Fig. 2 in page 8.
Variable Range Of PCAO Output Depend On "CONTRAST" Control Function	$\Delta e_{PCAO}(CNT)$	11	12	13	dB	Variable Range of PCAO output level when CNT voltage is changed from 0 V to 9 V. PCAI input is shown by Fig. 2 in page 8.
Frequency Response Of Video & Chroma Amplifier	FR_{PCA}	-3	0		dB	Gain inconstancy when PCAI input signal frequency changes from 200 kHz to 4.2 MHz. PCAI input signal is shown by Fig. 1 in page 8.
Voltage Gain Of Video Signal Processor	A_{PSP}	10	12	14	dB	Y output level comparing with PIN input signal. PCAI input signal is shown by Fig. 1 in page 8. The input signal frequency is 200 kHz.
"BRIGHTNESS" Control Voltage Distribution for Standard Y Output Level	V_{BRT}	7.9	8.2	8.5	V	Applied BRT voltage when black level of Y output is controlled to 6 V. PCAI input is 300 mV _{p-p} deflection synchronous signal only.
Y Black Level At a BRT Voltage -1	$V_Y(BRT)1$	6.0	7.0		V	Black level of Y output when BRT voltage is 7.5 V. PCAI input is 300 mV _{p-p} deflection synchronous signal only.
Y Black Level At a BRT Voltage -2	$V_Y(BRT)2$		1.5	2.0	V	Black level of Y output when BRT voltage is 9.5 V. PCAI input is 300 mV _{p-p} deflection synchronous signal only.

μPC1401C

NEC ELECTRON DEVICE

CHARACTERISTICS	SYMBOL	MIN.	TYP.	MAX.	UNIT	CONDITIONS
Frequency Response Of Video Signal Processor Depend On "SHARPNESS" Control Function -1	FRY(SHP)1	-5.5	-3.5	-1.5	dB	Difference of gain for 2 MHz signal against one for 200 kHz signal, when SHP voltage is 9 V. PCAI input is shown by Fig. 1 in page 8.
Frequency Response Of Video Signal Processor Depend On "SHARPNESS" Control Function -2	FRY(SHP)2	+6.0	+9.0	+12	dB	Difference of gain for 2 MHz signal against one for 200 kHz signal, when SHP voltage is 0 V. PCAI input is shown by Fig. 1 in page 8.
Null Point Of "SHARPNESS" Control Voltage	VNSHP	4.6	4.9	5.2	V	SHP voltage is adjusted as frequency response of video signal processor is constant for signal from 200 kHz to 2.0 MHz. PCAI Input is shown by Fig. 1 in page 8.
Temperature Coefficient Of Y Black Level	$\Delta V_Y(T_a)$	0	+2.5	+5.0	mV/°C	Temperature Coefficient of black level of Y output when ambient temperature changes from -10 °C to +60 °C. Black level of Y output is set to 6 V at 25 °C.

Synchronization & Deflection Part

CHARACTERISTICS	SYMBOL	MIN.	TYP.	MAX.	UNIT	CONDITIONS	
Horizontal Part Powersupply Current	I _{CCH}	8	12	16	mA	V _{CCH} (=V _{CCM})=12 V	
Synchronous Signal Separator Input DC Voltage	ESSI	7.3	7.6	7.9	V	SSI terminal DC voltage with no input.	
Vertical Free-running Frequency -1	f _{vo1}		f _H /296		Hz	Frequency ratio of VDFB terminal signal against HPD output, when SSI voltage is set to V _{CCM} .	
Vertical Free-running Frequency -2	f _{vo2}		f _H /232		Hz	Frequency ratio of VDFB terminal signal against HPD output, when SSI voltage is set to 0 V.	
Lowest VDFB Input Voltage Interrupting VPD Pulse	V _{LVDFB}	3.7	4.0	4.3	V	Lowest VDFB voltage with which VFD output is disappeared.	
Vertical Blanking Pulse Width	PW _{VBLK}	See Fig. 3 in page 8					Watch blanking time length of Y output. PCAI input is 300 mV _{p-p} deflection synchronous signal only.
VPD Output Pulse Width	PW _{VPD}	See Fig. 3 in page 8					Watch VPD output pulse width. PCAI input is 300 mV _{p-p} deflection synchronous signal only.
Voltage Gain Distribution Of Vertical Pre-driver	A _{VPD}	4.5	6.0	7.5	V/V	Change of VPD output comparing with change of VAFB input when VAFB DC voltage is changed from 3.5 V to 3.7 V.	
Lowest V _{CCM} Available To Vertical Frequency Divider	V _{LCCM(VO)}		3.3	4.0	V	Lowest V _{CCM} with which VDFB pulse appears. PCAI input is 300 mV _{p-p} deflection synchronous signal only.	
Lowest V _{CCM} Available To Vertical Synchronizer	V _{LCCM(VS)}		4.1	5.0	V	Lowest V _{CCM} with which VDFB terminal signal synchronizes with synchronous signal of PCAI input. The input is 300 mV _{p-p} deflection synchronous signal only.	
Horizontal Free-running Frequency	f _{HO}	-50	0	+50	Hz	Frequency aberration of HPD output from 15.734 kHz.	

NEC ELECTRON DEVICE

μPC1401C

CHARACTERISTICS	SYMBOL	MIN.	TYP.	MAX.	UNIT	CONDITIONS
Supply Voltage Dependence			+5	+20	Hz	Frequency change of HPD output when VCCH is changed from 11 V to 13 V. <small>Measured with HPD.</small>

μ PC1401C

Fig. 1 TEST SIGNAL OF FR_{PCA}, A_{PSP}, F_{RY(SHP)1}, F_{RY(SHP)2}, AND V_{NSHP}

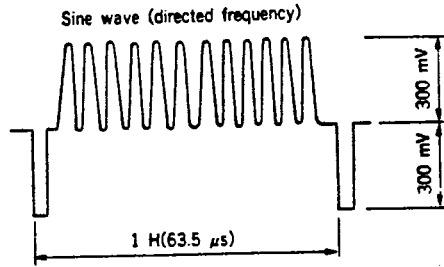

Fig. 2 TEST SIGNAL OF A_{PCA}, e_{PCAO(CNT)}, AND 4e_{PCAO(CNT)}

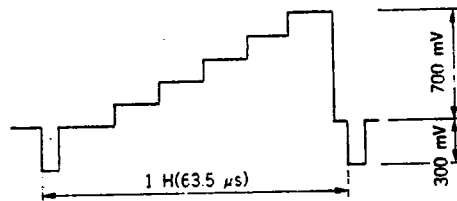
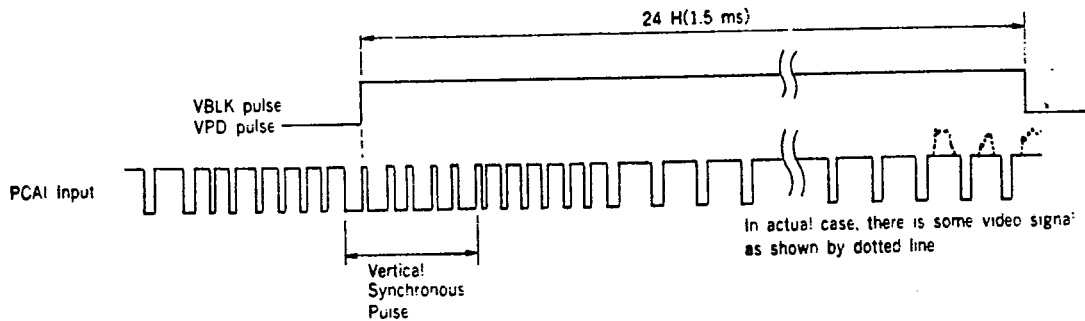
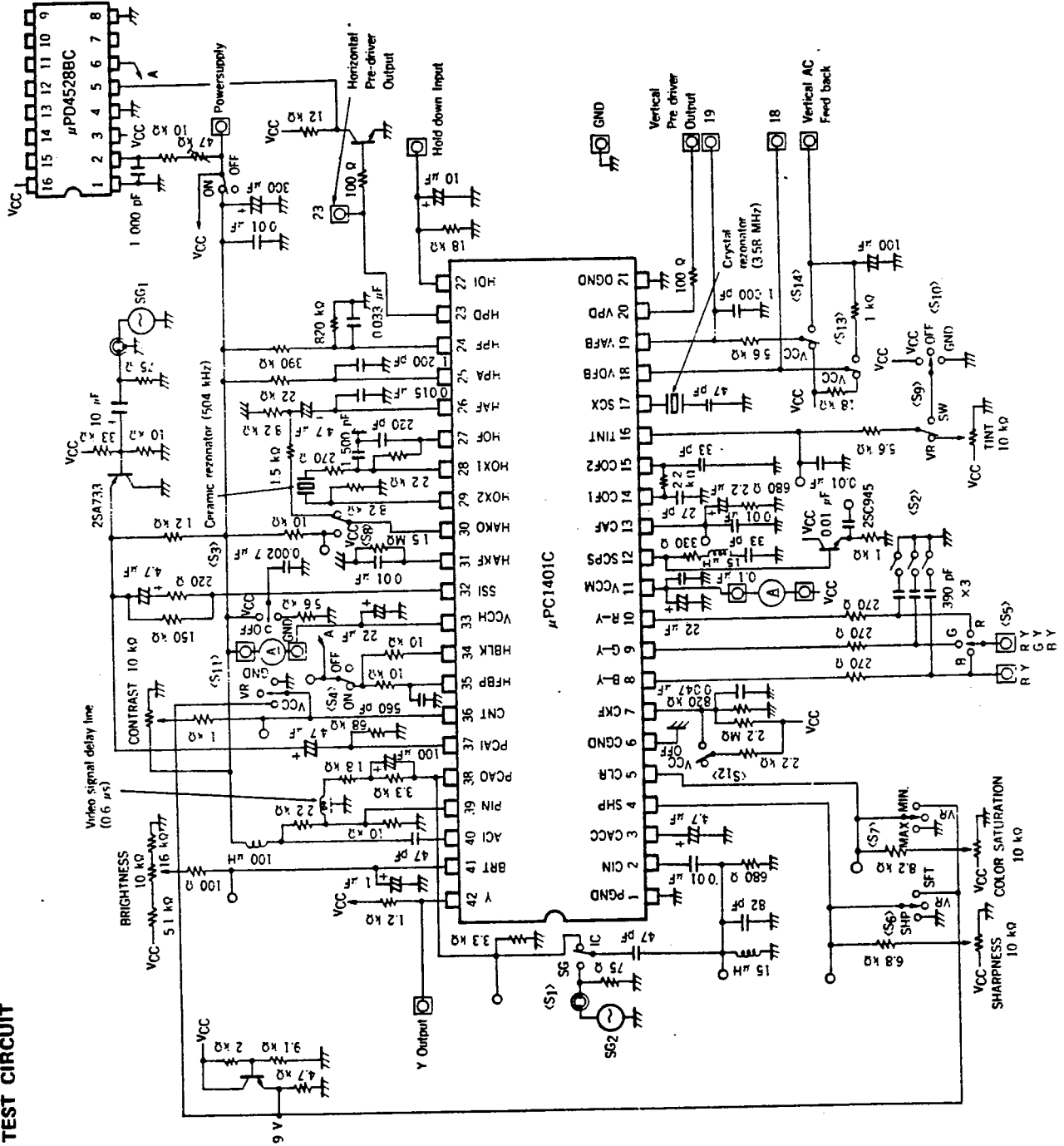

Fig. 3 SIGNAL TIMING OF PW_{VBLK}, AND PW_{VPD}



TEST CIRCUIT



μ PC1401C

EXAMPLE OF APPLICATION CIRCUIT

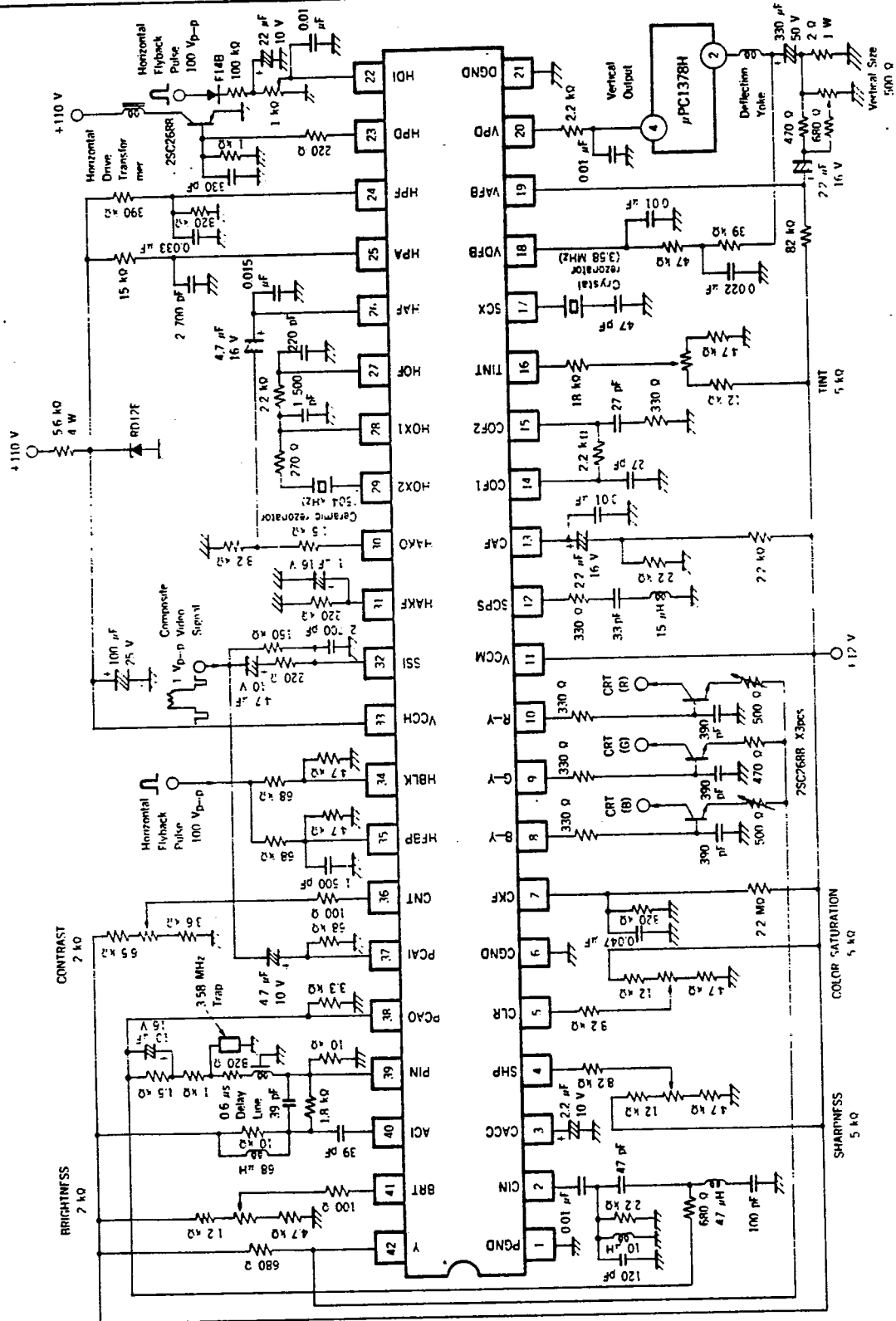

NEC Corporation

INTERNATIONAL ELECTRON DEVICES DIV.
 NEC Building, 33-1, Shiba Gocho
 Minato-ku, Tokyo 108, Japan
 Tel: Tokyo 454-1111
 Telex Address: NECTOK J22686
 Cable Address: MICROPHONE TOKYO

IN-1497
 APR-20-83M
 Printed in Japan