

***THIS DOCUMENT IS FOR MAINTENANCE
PURPOSES ONLY AND IS NOT
RECOMMENDED FOR NEW DESIGNS***

SL1454

WIDEBAND LINEAR FM DETECTOR FOR SATELLITE TV

The SL1454 is a wideband FM demodulator designed to operate with a carrier frequency between 70MHz and 150MHz. The internal circuitry of the device is similar to that of the SL1452 except that the quadrature demodulator operates at the input frequency.

FEATURES

- Excellent Threshold
- Negligible Differential Gain and Phase Errors
- Video Bandwidth Suitable for High Definition TV
- High Sensitivity and Wide Dynamic Range
- Wide Operating Frequency Range: 70 to 150MHz

ORDERING INFORMATION

SL1454 NA DP (14-lead plastic DIL package)

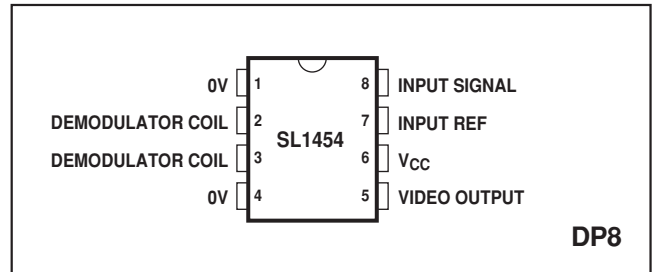

Fig. 1 Pin connections - top view

ABSOLUTE MAXIMUM RATINGS

Operating temperature range	-10°C to +80°C
Supply voltage, pin 6	7V
Input voltage, pin 7 or 8	2.5V p-p
Storage temperature	-55°C to +150°C
Junction temperature	+175°C

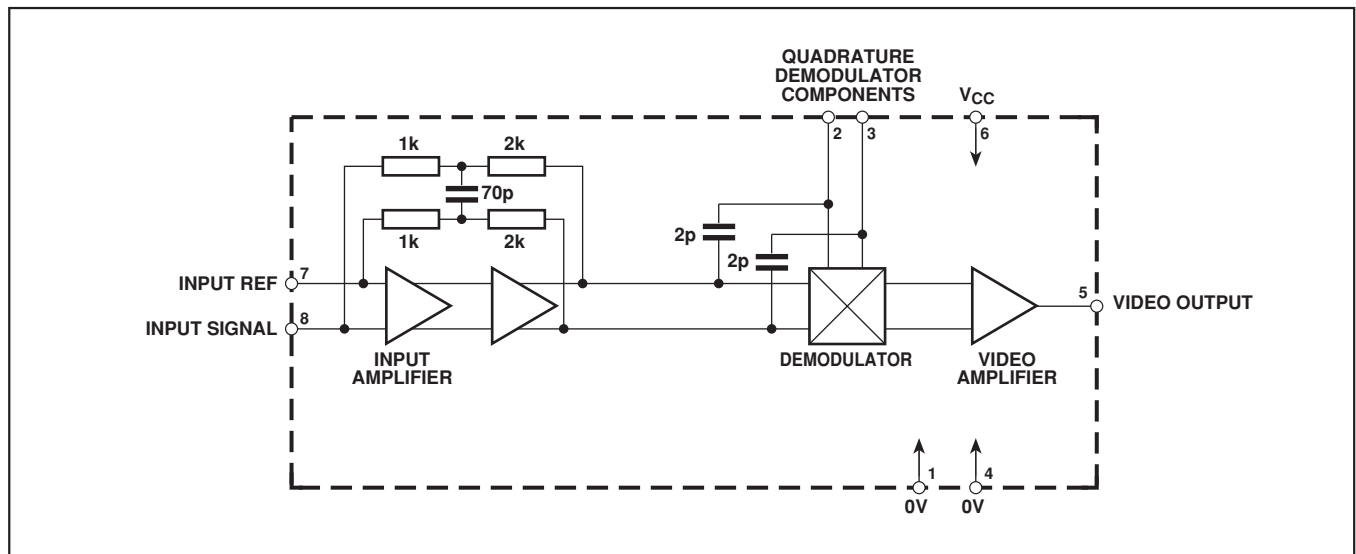

Fig. 2 Block diagram

ELECTRICAL CHARACTERISTICS

These characteristics are guaranteed over the following conditions (unless otherwise stated):

$$T_{AMB} = +25^{\circ}\text{C}, V_{CC} = +4.5\text{V to } +5.5\text{V}, Q = 2, f = 140\text{MHz}$$

Characteristic	Pin	Value			Units	Conditions
		Min.	Typ.	Max.		
Supply current, I_{CC}	6		30	35	mA	$V_{CC} = 5\text{V}$ $\Delta f = 21.4\text{MHz p-p}$
Video output voltage	5		0.4		V p-p	
Video bandwidth	5		10		MHz	
Minimum operating frequency	8		70		MHz	
Maximum operating frequency	8		150		MHz	
Input voltage	8	10		300	mVrms	
Intermodulation	5		-50		dB	
Differential gain	5		$< \pm 1$		%	Product of input modulation: $f = 4.4\text{MHz}$, $\Delta f = 21.4\text{MHz p-p}$ and $f = 6\text{MHz}$, $\Delta f = 3\text{MHz p-p}$ (PAL colour and sound subcarriers). $\Delta f = 21.4\text{MHz p-p}$. Demodulated staircase referred to input staircase before modulation.
Differential phase	5		$< \pm 1$		deg	
Signal-to-noise ratio	5	70			dB	Ratio of output with $\Delta f = 21.4\text{MHz p-p}$ at 1MHz to output rms noise in 10MHz bandwidth with $\Delta f = 0$.

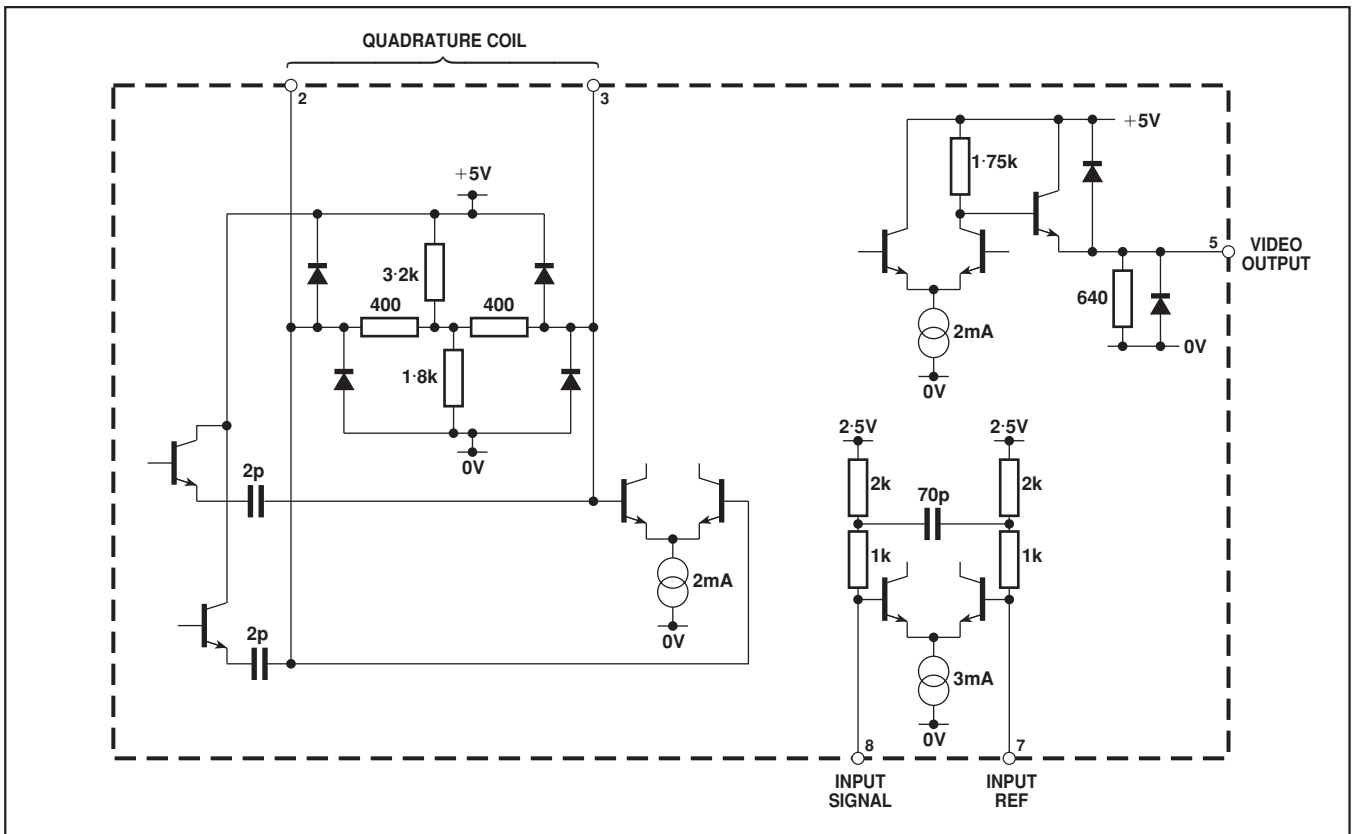

Fig. 3 Input/output interface circuits

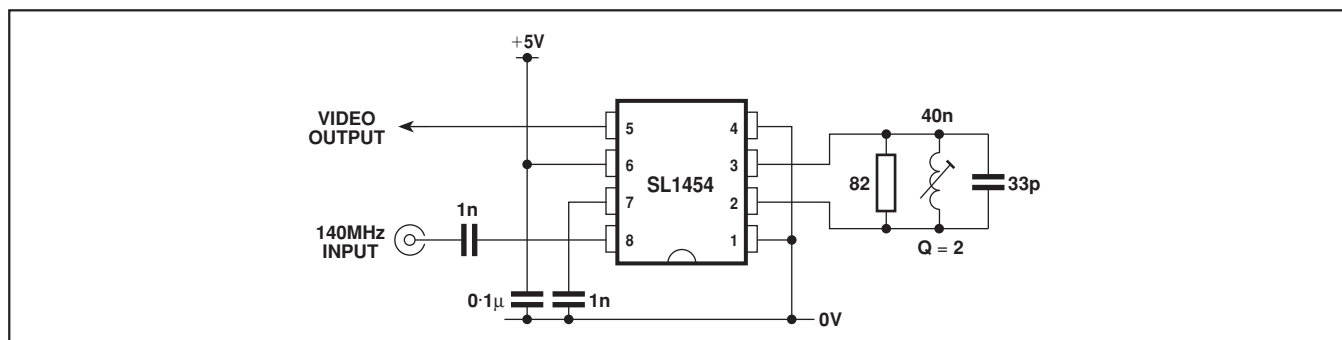

Fig. 4 Typical application for 140MHz

APPLICATION NOTES

The SL1454 FM demodulator has a very simple application with very low external component count. This is demonstrated by the applications circuit diagram Fig. 4, but as with most integrated circuits, particularly those working at high frequencies, some attention to good RF layout techniques and correct component selection will ensure optimum results.

A good layout can usually be ensured by the simple precaution of keeping all components close to the SL1454, maintaining short lead lengths and ensuring a good low impedance ground plane. Double sided board layout enables these objectives to be easily met, but is not essential for satisfactory operation. All coupling and decoupling capacitors should be chosen for low impedance characteristics at high frequencies. A fairly stable component should be selected for the quadrature coil tuning capacitor to prevent excessive drift. The power supply decoupling capacitor from pin 6 to ground should be 0.1µF minimum, but the input coupling and decoupling values can be smaller, about 330pF being adequate.

The only remaining components to be selected are those forming the quadrature circuit on pins 2 and 3 and some care in the determination of values for these is required if maximum performance is to be obtained.

Choose suitable values for L and C to resonate at the intermediate frequency you are applying to the device, using:

$$f = \frac{1}{2\pi\sqrt{LC}}$$

The value of C should be greater than 15pF to prevent stray capacitance effects introducing errors and distortion of the demodulation S-curve, but the use of very large capacitances with small inductance values will lower the impedance of the tuned circuit at the required Q value, reducing the drive level to the demodulator and thereby restricting the video output available.

Once suitable L and C values have been determined, the working Q for the quadrature circuit should be set, the Q value determining the video output level and bandwidth. Video output is proportional to Q whereas video bandwidth is inversely proportional. The effect of Q variations on video bandwidth and amplitude can be determined from Table 1 and the graphs in Fig.5.

A value for total damping resistor value to obtain the required Q can be calculated from:

$$R = Q2\pi fL$$

The internal 800Ω resistance between pins 2 and 3 must be allowed for when calculating R.

As can be seen from the graphs in Fig.5, for the demodulator to demodulate a 20MHz peak to peak deviation signal with optimum linearity a very low Q value needs to be chosen (<2). However, this has the disadvantage of producing a demodulator with a very low peak to peak video output level.

One way of increasing the linear region of the S-curve without

reducing the video output level is to incorporate a dual tuned circuit in the quadrature network. This can easily be done by capacitively coupling another parallel tuned circuit to the normal quadrature tuned circuit.

Fig. 6 shows an example of this form of dual tuned circuit, both sections having the same Q factor and coupling capacitors chosen to give the best linearity (linear phase response). Fig.5(b) shows the advantages of the dual tuned circuit. The effect of varying the Q factor of the dual tuned circuit on bandwidth is also described by Table 1.

Example

Design a quadrature circuit to demodulate a 140MHz carrier with centre with 21.4MHz peak to peak deviation, modulated with a 25Hz triangular dispersion wave form of 2MHz peak to peak deviation. The video bandwidth required is 9MHz.

Choose L = 40nH

then C = 32.309pF (nearest preferred value 33pF)

The next value to choose is the Q factor. As dispersion is employed, linearity over the full 21.4MHz range needs to be optimised. The graphs in Fig.5 show that either a single tuned circuit with a Q of 2, or a dual tuned circuit with a Q of 3 is adequate. The dual tuned circuit has the advantage that the peak to peak video output is larger than that of the single tuned circuit, but extra components are required. Both circuits have a larger video bandwidth than the required 9MHz. The value of the damping resistor for the required Q is calculated below:

For Q = 2

Total R = Q2πfL

$$= 2 \times 2 \times \pi \times 140 \times 10^6 \times 0.04 \times 10^{-6}$$

$$= 70.3717\Omega$$

Allowing for the internal 800Ω resistance between pins 2 and 3 (see Fig. 3), the external resistance should be 77.1Ω. Choose 82Ω.

For Q = 3

Total R = Q2πfL

$$= 3 \times 2 \times \pi \times 140 \times 10^6 \times 0.04 \times 10^{-6}$$

$$= 105.56\Omega$$

Allowing for the internal 800Ω resistance, the external resistance should be 121.5Ω, so choose 120Ω.

When using a dual tuned circuit the value of coupling capacitor is dependent of the Q factor. Table 2 gives a guide to the values needed for best linearity.

Q	Bandwidth
6	10MHz
4	11MHz
2	12MHz

Table 1

Q	Coupling capacitor
6	3.9pF
4	5.6pF
3	10pF

Table 2

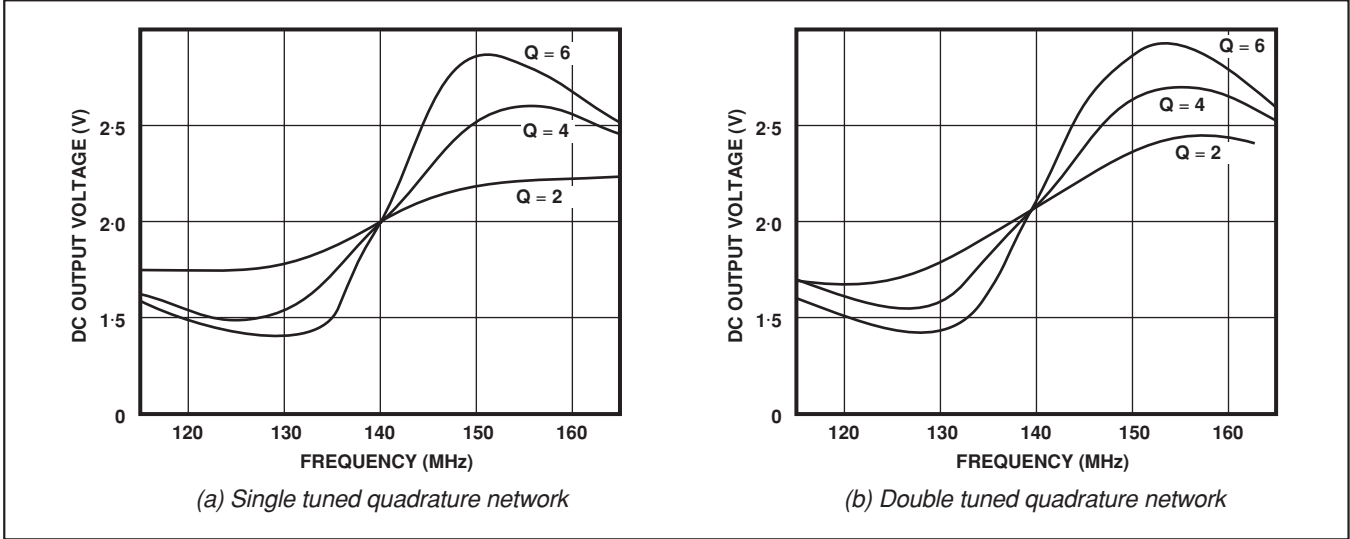

Fig. 5 Output voltage v. input frequency

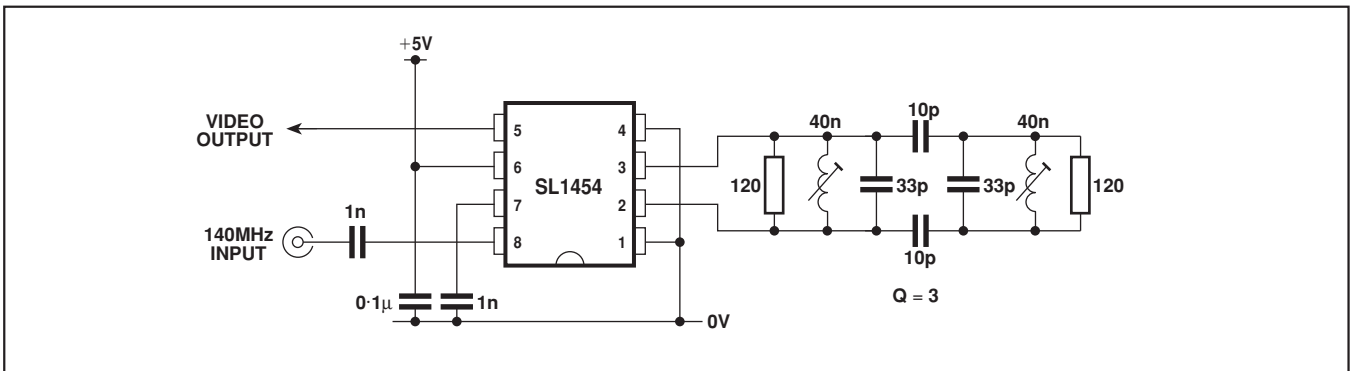
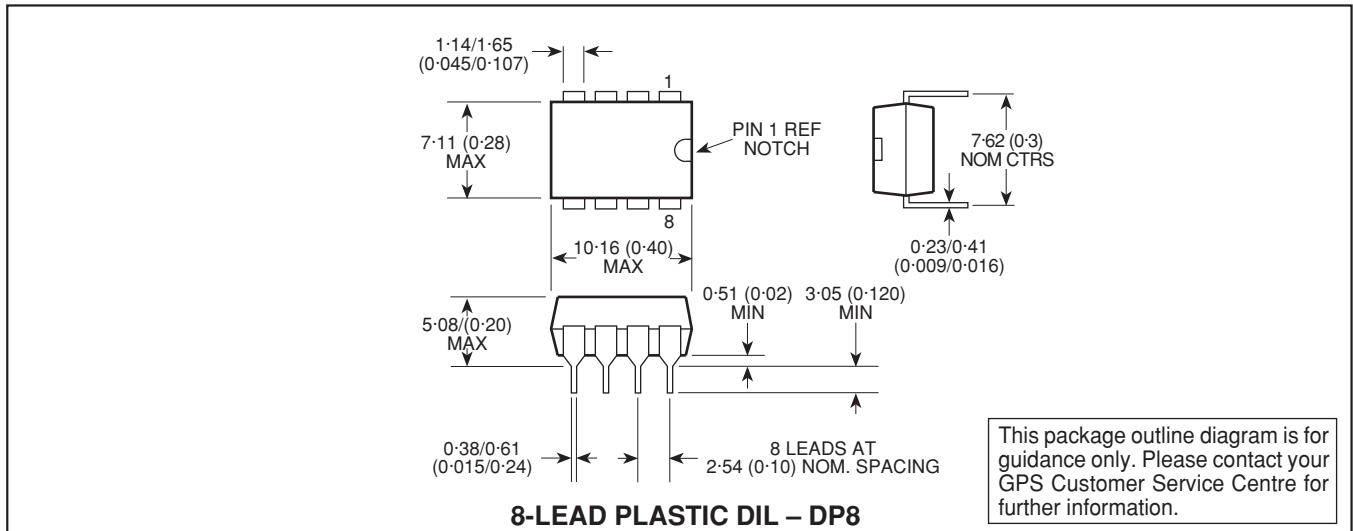

Fig. 6 Example of double tuned quadrature circuit

NOTES

PACKAGE DETAILS

Dimensions are shown thus: mm (in)

**HEADQUARTERS OPERATIONS****GEC PLESSEY SEMICONDUCTORS**

Cheney Manor, Swindon,
Wiltshire SN2 2QW, United Kingdom.
Tel: (0793) 518000
Fax: (0793) 518411

GEC PLESSEY SEMICONDUCTORS

P.O. Box 660017
1500 Green Hills Road,
Scotts Valley, CA95067-0017
United States of America.
Tel (408) 438 2900
Fax: (408) 438 5576

CUSTOMER SERVICE CENTRES

- **FRANCE & BENELUX** Les Ulis Cedex Tel: (1) 64 46 23 45 Tx: 602858F
Fax : (1) 64 46 06 07
 - **GERMANY** Munich Tel: (089) 3609 06-0 Tx: 523980 Fax : (089) 3609 06-55
 - **ITALY** Milan Tel: (02) 66040867 Fax: (02) 66040993
 - **JAPAN** Tokyo Tel: (03) 3296-0281 Fax: (03) 3296-0228
 - **NORTH AMERICA Integrated Circuits and Microwave Products**, Scotts Valley, USA
Tel: (408) 438 2900 Fax: (408) 438 7023.
Hybrid Products, Farmingdale, USA Tel (516) 293 8686 Fax: (516) 293 0061.
 - **SOUTH EAST ASIA** Singapore Tel: (65) 3827708 Fax: (65) 3828872
 - **SWEDEN** Stockholm Tel: 4687029770 Fax: 4686404736
 - **UK, EIRE, DENMARK, FINLAND & NORWAY**
Swindon Tel: (0793) 518510 Tx: 444410 Fax : (0793) 518582
- These are supported by Agents and Distributors in major countries world-wide.

© GEC Plessey Semiconductors 1993 Publication No. DS2039 Issue No. 2.1 September 1993

This publication is issued to provide information only which (unless agreed by the Company in writing) may not be used, applied or reproduced for any purpose nor form part of any order or contract nor to be regarded as a representation relating to the products or services concerned. No warranty or guarantee express or implied is made regarding the capability, performance or suitability of any product or service. The Company reserves the right to alter without prior knowledge the specification, design or price of any product or service. Information concerning possible methods of use is provided as a guide only and does not constitute any guarantee that such methods of use will be satisfactory in a specific piece of equipment. It is the user's responsibility to fully determine the performance and suitability of any equipment using such information and to ensure that any publication or data used is up to date and has not been superseded. These products are not suitable for use in any medical products whose failure to perform may result in significant injury or death to the user. All products and materials are sold and services provided subject to the Company's conditions of sale, which are available on request.



**For more information about all Zarlink products
visit our Web Site at
www.zarlink.com**

Information relating to products and services furnished herein by Zarlink Semiconductor Inc. trading as Zarlink Semiconductor or its subsidiaries (collectively "Zarlink") is believed to be reliable. However, Zarlink assumes no liability for errors that may appear in this publication, or for liability otherwise arising from the application or use of any such information, product or service or for any infringement of patents or other intellectual property rights owned by third parties which may result from such application or use. Neither the supply of such information or purchase of product or service conveys any license, either express or implied, under patents or other intellectual property rights owned by Zarlink or licensed from third parties by Zarlink, whatsoever. Purchasers of products are also hereby notified that the use of product in certain ways or in combination with Zarlink, or non-Zarlink furnished goods or services may infringe patents or other intellectual property rights owned by Zarlink.

This publication is issued to provide information only and (unless agreed by Zarlink in writing) may not be used, applied or reproduced for any purpose nor form part of any order or contract nor to be regarded as a representation relating to the products or services concerned. The products, their specifications, services and other information appearing in this publication are subject to change by Zarlink without notice. No warranty or guarantee express or implied is made regarding the capability, performance or suitability of any product or service. Information concerning possible methods of use is provided as a guide only and does not constitute any guarantee that such methods of use will be satisfactory in a specific piece of equipment. It is the user's responsibility to fully determine the performance and suitability of any equipment using such information and to ensure that any publication or data used is up to date and has not been superseded. Manufacturing does not necessarily include testing of all functions or parameters. These products are not suitable for use in any medical products whose failure to perform may result in significant injury or death to the user. All products and materials are sold and services provided subject to Zarlink's conditions of sale which are available on request.

Purchase of Zarlink's I²C components conveys a licence under the Philips I²C Patent rights to use these components in an I²C System, provided that the system conforms to the I²C Standard Specification as defined by Philips.

Zarlink, ZL and the Zarlink Semiconductor logo are trademarks of Zarlink Semiconductor Inc.

Copyright 2003, Zarlink Semiconductor Inc. All Rights Reserved.

TECHNICAL DOCUMENTATION - NOT FOR RESALE
