

**SOT-23 Formed SMD Package**

**BC807  
BC808**

**SILICON PLANAR EPITAXIAL TRANSISTORS**

*P-N-P transistor*

**Marking**

- BC807 = 5D
- BC807-16 = 5A
- BC807-25 = 5B
- BC807-40 = 5C
- BC808 = 5H
- BC808-16 = 5E
- BC808-25 = 5F
- BC808-40 = 5G

**PACKAGE OUTLINE DETAILS  
ALL DIMENSIONS IN mm**

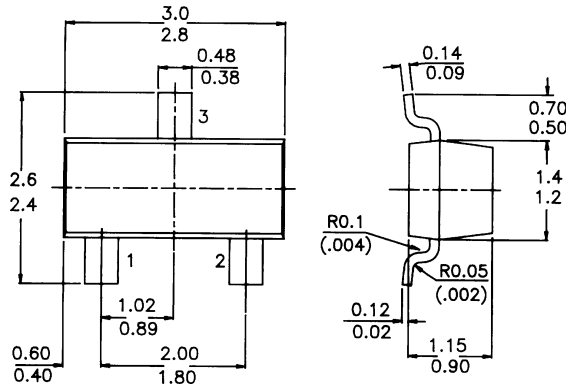

**Pin configuration**

- 1 = BASE
- 2 = EMITTER
- 3 = COLLECTOR

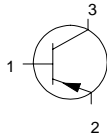

**ABSOLUTE MAXIMUM RATINGS**

	<b>BC807</b>	<b>8C808</b>
Collector-emitter voltage ( $V_{BE} = 0$ )	$-V_{CES}$ max. 50	30 V
Collector-emitter voltage (open base)	$-V_{CE0}$ max. 45	25 V
Collector current (peak value)	$-I_{CM}$ max.	1000 mA
Total power dissipation up to $T_{amb} = 25\text{ }^\circ\text{C}$	$P_{tot}$ max.	250 mW
Junction temperature	$T_j$ max.	150 $^\circ\text{C}$
Transition frequency at $f = 100\text{ MHz}$ $-I_C = 10\text{ mA}; -V_{CE} = 5\text{ V}$	$f_T >$	80 MHz

**BC807  
BC808**

**RATINGS** (at  $T_A = 25^\circ\text{C}$  unless otherwise specified)

Limiting values		<b>BC807</b>	<b>BC808</b>
Collector-emitter voltage ( $V_{BE} = 0$ )	$-V_{CES}$ max.	50	30 V
Collector-emitter voltage (open base) $-I_C = 10$ mA	$-V_{CE0}$ max.	45	25 V
Emitter-base voltage (open collector)	$-V_{EB0}$ max.	5	5 V
Collector current (DC)	$-I_C$ max.	500	mA
Collector current (peak value)	$-I_{CM}$ max.	1000	mA
Emitter current (peak value)	$I_{EM}$ max.	1000	mA
Base current (DC)	$-I_B$ max.	100	mA
Base current (peak value)	$-I_{BM}$ max.	200	mA
Total power dissipation at $T_{amb} = 25^\circ\text{C}$ *	$P_{tot}$ max.	250	mW
Storage temperature	$T_{stg}$	-55 to +150	$^\circ\text{C}$
Junction temperature	$T_j$ max.	150	$^\circ\text{C}$

**THERMAL RESISTANCE\***

From junction to ambient	$R_{th\ j-a}$ =	500	K/W
--------------------------	-----------------	-----	-----

**CHARACTERISTICS**

$T_j = 25^\circ\text{C}$  unless otherwise specified

Collector cut-off current $I_E = 0; -V_{CB} = 20\text{V}; T_j = 25^\circ\text{C}$	$-I_{CB0}$ max.	100	nA
$I_E = 0; -V_{CB} = 20\text{V}; T_j = 150^\circ\text{C}$	$-I_{CB0}$ max.	5	mA
Emitter cut-off current $I_C = 0; V_{EB} = 5\text{V}$	$-I_{EB0}$ max.	10	mA
Base emitter voltage * $-I_C = 500\text{ mA}; -V_{CE} = 1\text{ V}$	$-V_{BE}$ max.	1,2	V
Saturation voltage $-I_C = 500\text{ mA}; -I_B = 50\text{ mA}$	$-V_{CEsat}$ max.	700	mV
D.C. current gain $-I_C = 500\text{ mA}; -V_{CE} = 1\text{ V}$	$h_{FE}$ min.	40	
$-I_C = 100\text{ mA}; -V_{CE} = 1\text{ V}; \text{BC807}; \text{BC808}$	$h_{FE}$	100 to 600	
$\text{BC807-16}$	$h_{FE}$	100 to 250	
$\text{BC808-16}$	$h_{FE}$	100 to 250	
$\text{BC807-25}$	$h_{FE}$	160 to 400	
$\text{BC808-25}$	$h_{FE}$	160 to 400	
$\text{BC807-40}$	$h_{FE}$	250 to 600	
$\text{BC808-40}$	$h_{FE}$	250 to 600	
Transition frequency at $f = 100\text{ MHz}$ $-I_C = 10\text{ mA}; -V_{CE} = 5\text{ V}$	$f_T$	>	80 MHz
Collector capacitance at $f = 1\text{ MHz}$ $I_E = I_e = 0; -V_{CB} = 10\text{ V}$	$C_c$	typ.	8 pF

## Notes

### Disclaimer

The product information and the selection guides facilitate selection of the CDIL's Discrete Semiconductor Device(s) best suited for application in your product(s) as per your requirement. It is recommended that you completely review our Data Sheet(s) so as to confirm that the Device(s) meet functionality parameters for your application. The information furnished on the CDIL Web Site/ CD is believed to be accurate and reliable. CDIL however, does not assume responsibility for inaccuracies or incomplete information. Furthermore, CDIL does not assume liability whatsoever, arising out of the application or use of any CDIL product; neither does it convey any license under its patent rights nor rights of others. These products are not designed for use in life saving/support appliances or systems. CDIL customers selling these products (either as individual Discrete Semiconductor Devices or incorporated in their end products), in any life saving/support appliances or systems or applications do so at their own risk and CDIL will not be responsible for any damages resulting from such sale(s).

CDIL strives for continuous improvement and reserves the right to change the specifications of its products without prior notice.



CDIL is a registered Trademark of  
**Continental Device India Limited**

C-120 Naraina Industrial Area, New Delhi 110 028, India.  
Telephone + 91-11-579 6150 Fax + 91-11-579 9569, 579 5290  
e-mail sales@cdil.com www.cdil.com