

TO-220 Plastic Package

**BD533, BD535, BD537
BD534, BD536, BD538**

BD533, 535, 537 NPN PLASTIC POWER TRANSISTORS
BD534, 536, 538 PNP PLASTIC POWER TRANSISTORS
Medium Power Linear and Switching Applications

PIN CONFIGURATION
1. BASE
2. COLLECTOR
3. EMITTER
4. COLLECTOR

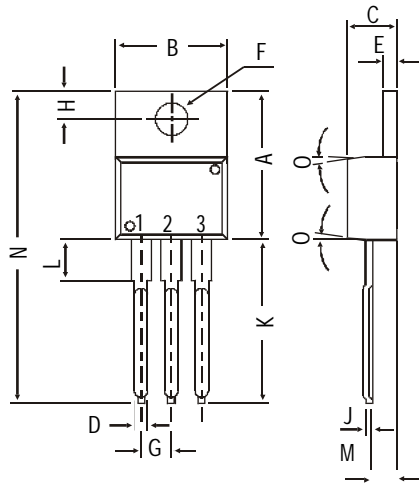
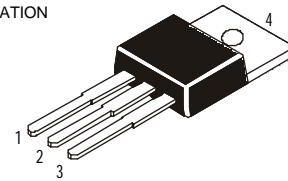

DIM	MIN.	MAX.
A	14.42	16.51
B	9.63	10.67
C	3.56	4.83
D		0.90
E	1.15	1.40
F	3.75	3.88
G	2.29	2.79
H	2.54	3.43
J		0.56
K	12.70	14.73
L	2.80	4.07
M	2.03	2.92
N		31.24
O	DEG 7	

All dimensions in mm.

ABSOLUTE MAXIMUM RATINGS

		533	535	537	
		534	536	538	
Collector-base voltage (open emitter)	V_{CB0} max.	45	60	80	V
Collector-emitter voltage (open base)	V_{CEO} max.	45	60	80	V
Collector and emitter current	I_C, I_E max.	8.0			A
Total power dissipation up to $T_C = 25^\circ\text{C}$	P_{tot} max.	50			W
Junction temperature	T_j max.	150			$^\circ\text{C}$
Collector-emitter saturation voltage	V_{CEsat} max.	0.8			V
$I_C = 2\text{ A}; I_B = 0.2\text{ A}$					
D.C. current gain	h_{FE} min.	20	20	15	
$I_C = 10\text{ mA}; V_{CE} = 5\text{ V}$					

RATINGS (at $T_A=25^\circ\text{C}$ unless otherwise specified)

		533	535	537	
		534	536	538	
Collector-base voltage (open emitter)	V_{CB0} max.	45	60	80	V
Collector-emitter voltage (open base)	V_{CEO} max.	45	60	80	V
Collector-emitter voltage ($V_{BE} = 0$)	V_{CES} max.	45	60	80	V
Emitter-base voltage (open collector)	V_{EBO} max.	5.0			V
Collector and emitter current	I_C, I_E max.	8.0			A

**BD533, BD535, BD537
BD534, BD536, BD538**

Base current	I_B	max.	1.0	A
Total power dissipation up to $T_C = 25^\circ\text{C}$	P_{tot}	max.	50	W
Junction temperature	T_j	max.	150	$^\circ\text{C}$
Storage temperature	T_{stg}		-65 to +150	$^\circ\text{C}$

THERMAL RESISTANCE

From junction to case	R_{thj-c}		2.5	$^\circ\text{C/W}$
From junction to ambient	R_{thj-a}		70	$^\circ\text{C/W}$

CHARACTERISTICS

$T_{amb} = 25^\circ\text{C}$ unless otherwise specified

			533	535	537
			534	536	538
Collector cutoff current					
$I_E = 0; V_{CB} = 45\text{ V}$	I_{CBO}	max.	100	-	- μA
$I_E = 0; V_{CB} = 60\text{ V}$	I_{CBO}	max.	-	100	- μA
$I_E = 0; V_{CB} = 80\text{ V}$	I_{CBO}	max.	-	-	100 μA
$V_{BE} = 0; V_{CE} = 45\text{V}$	I_{CES}	max.	100	-	- μA
$V_{BE} = 0; V_{CE} = 60\text{V}$	I_{CES}	max.	-	100	- μA
$V_{BE} = 0; V_{CE} = 80\text{V}$	I_{CES}	max.	-	-	100 μA
Emitter cut-off current					
$I_C = 0; V_{EB} = 5\text{ V}$	I_{EBO}	max.		1.0	mA
Breakdown voltages					
$I_C = 100\text{ mA}; I_B = 0$	$V_{CEO(sus)}^*$	min.	45	60	80 V
$I_C = 1\text{ mA}; I_E = 0$	V_{CBO}	min.	45	60	100 V
$I_E = 1\text{ mA}; I_C = 0$	V_{EBO}	min.		5.0	V
Saturation voltages					
$I_C = 2.0\text{ A}; I_B = 0.2\text{ A}$	V_{CEsat}^*	max.		0.8	V
$I_C = 6.0\text{ A}; I_B = 0.6\text{ A}$	V_{CEsat}^*	typ.		0.8	V
Base-emitter on voltage					
$I_C = 2\text{A}; V_{CE} = 2\text{V}$	$V_{BE(on)}^*$	max.		1.5	V
D.C. current gain					
$I_C = 10\text{mA}; V_{CE} = 5\text{V}$	h_{FE}^*	min.	20	20	15
$I_C = 500\text{mA}; V_{CE} = 2\text{V}$	h_{FE}^*	min.		40	
$I_C = 2\text{A}; V_{CE} = 2\text{V}$	h_{FE}^*	min.	25	25	15
Transition frequency					
$I_C = 500\text{ mA}; V_{CE} = 1\text{V}$	f_T	min.		3.0	MHz
h_{FE} Groups:					
$I_C = 2\text{A}; V_{CE} = 2\text{V}$	J	min.		30	
		max.		75	
$I_C = 3\text{A}; V_{CE} = 2\text{V}$		min.		15	
$I_C = 2\text{A}; V_{CE} = 2\text{V}$	K	min.		40	
		max.		100	
$I_C = 3\text{A}; V_{CE} = 2\text{V}$		min.		20	

* Pulsed: pulse duration = 300 μs ; duty cycle = 1.5%.

Notes

Disclaimer

The product information and the selection guides facilitate selection of the CDIL's Discrete Semiconductor Device(s) best suited for application in your product(s) as per your requirement. It is recommended that you completely review our Data Sheet(s) so as to confirm that the Device(s) meet functionality parameters for your application. The information furnished on the CDIL Web Site/ CD is believed to be accurate and reliable. CDIL however, does not assume responsibility for inaccuracies or incomplete information. Furthermore, CDIL does not assume liability whatsoever, arising out of the application or use of any CDIL product; neither does it convey any license under its patent rights nor rights of others. These products are not designed for use in life saving/support appliances or systems. CDIL customers selling these products (either as individual Discrete Semiconductor Devices or incorporated in their end products), in any life saving/support appliances or systems or applications do so at their own risk and CDIL will not be responsible for any damages resulting from such sale(s).

CDIL strives for continuous improvement and reserves the right to change the specifications of its products without prior notice.



CDIL is a registered Trademark of
Continental Device India Limited

C-120 Naraina Industrial Area, New Delhi 110 028, India.
Telephone + 91-11-579 6150 Fax + 91-11-579 9569, 579 5290
e-mail sales@cdil.com www.cdil.com