

**NPN SILICON PLANAR EPITAXIAL TRANSISTOR**

**BF173**



**TO-72  
Metal Can Package**

**For use in LF Video Amplifier (uncontrolled stages) of Television Receivers.**

**ABSOLUTE MAXIMUM RATINGS**

DESCRIPTION	SYMBOL	VALUE	UNIT
Collector Base Voltage	$V_{CBO}$	40	V
Collector Emitter Voltage	$V_{CEO}$	25	V
Emitter Base Voltage	$V_{EBO}$	4	V
Collector Current Continuous	$I_C$	25	mA
Base Current Continuous	$I_B$	2	mA
Total Power Dissipation @ $T_a=45^\circ\text{C}$	$P_D$	200	mW
Operating and Storage Junction Temperature Range	$T_j, T_{stg}$	- 65 to +175	$^\circ\text{C}$

**THERMAL RESISTANCE**

Junction to ambient in free air	$R_{th(j-a)}$	650	$^\circ\text{C/W}$
---------------------------------	---------------	-----	--------------------

**ELECTRICAL CHARACTERISTICS ( $T_a=25^\circ\text{C}$  unless specified otherwise )**

DESCRIPTION	SYMBOL	TEST CONDITION	MIN	TYP	MAX	UNIT
Collector Emitter Voltage	$V_{CEO}$	$I_C=2\text{mA}, I_B=0$	25			V
Collector Base Voltage	$V_{CBO}$	$I_C=10\mu\text{A}, I_E=0$	40			V
Emitter Base Voltage	$V_{EBO}$	$I_E=10\mu\text{A}, I_C=0$	4			V
DC Current Gain	$*h_{FE}$	$I_C=7\text{mA}, V_{CE}=10\text{V}$	38			
		$I_C=20\text{mA}, V_{CE}=2\text{V}$	15			
Base Emitter On Voltage	$*V_{BE(on)}$	$I_C=7\text{mA}, V_{CE}=10\text{V}$			0.9	V

**DYNAMIC CHARACTERISTICS**

Transition Frequency	$f_T$	$V_{CE}=10\text{V}, I_C=5\text{mA}, f=100\text{MHz}$		550		MHz
Feedback Capacitance	$C_{re}$	$V_{CB}=10\text{V}, I_C=1\text{mA}, f=10.7\text{MHz}$		0.23		pF

\* Pulse Test: Pulse Width  $\leq 300\mu\text{s}$ , Duty Cycle  $\leq 1\%$

TO-72 Metal Can Package

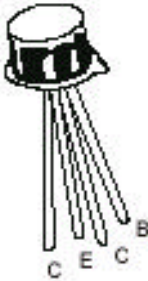
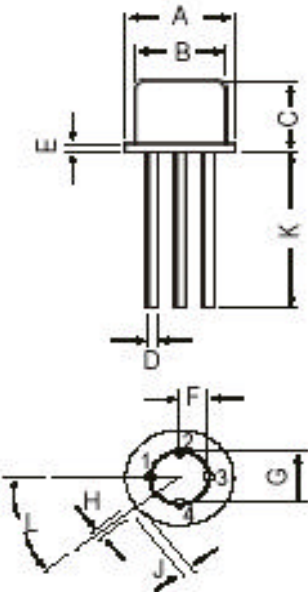

- PIN CONFIGURATION
1. BASE
  2. EMITTER
  3. COLLECTOR
  4. CASE

All dimensions in mm.

DIM	MIN.	MAX.
A	5.24	5.84
B	4.52	4.95
C	4.31	5.33
D	0.40	0.53
E	—	0.76
F	1.14	1.39
G	2.28	2.97
H	0.91	1.17
J	0.71	1.22
K	12.70	—
L	12 DEG	48 DEG

Packing Detail

PACKAGE	STANDARD PACK		INNER CARTON BOX		OUTER CARTON BOX		
	Details	Net Weight/Qty	Size	Qty	Size	Qty	Gr Wt
TO-72	1 K/Polybag	325 gm/1K pcs	3" x 7.5" x 7.5"	5K	17" x 15" x 13.5"	80K	32 lbs

### **Disclaimer**

The product information and the selection guides facilitate selection of the CDIL's Discrete Semiconductor Device(s) best suited for application in your product(s) as per your requirement. It is recommended that you completely review our Data Sheet(s) so as to confirm that the Device(s) meet functionality parameters for your application. The information furnished on the CDIL Web Site/CD are believed to be accurate and reliable. CDIL however, does not assume responsibility for inaccuracies or incomplete information. Furthermore, CDIL does not assume liability whatsoever, arising out of the application or use of any CDIL product; neither does it convey any license under its patent rights nor rights of others. These products are not designed for use in life saving/support appliances or systems. CDIL customers selling these products (either as individual Discrete Semiconductor Devices or incorporated in their end products), in any life saving/support appliances or systems or applications do so at their own risk and CDIL will not be responsible for any damages resulting from such sale(s).

CDIL strives for continuous improvement and reserves the right to change the specifications of its products without prior notice.



CDIL is a registered Trademark of  
Continental Device India Limited

C-120 Naraina Industrial Area, New Delhi 110 028, India.  
Telephone + 91-11-2579 6150 Fax + 91-11-2579 9569, 2579 5290  
e-mail sales@cdil.com www.cdil.com, www.cdilsemi.com