

**SOT-23 Formed SMD Package**

**BF820**  
**BF822**

**SILICON EPITAXIAL TRANSISTORS**

*N-P-N transistors*

**Marking**

BF820 = 1V  
 BF822 = 1X

**PACKAGE OUTLINE DETAILS**  
 ALL DIMENSIONS IN mm

**Pin configuration**

1 = BASE  
 2 = EMITTER  
 3 = COLLECTOR

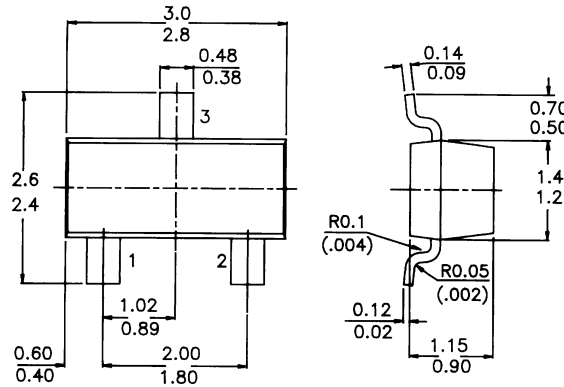
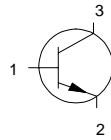

**ABSOLUTE MAXIMUM RATINGS**

		<b>BF820</b>	<b>BF822</b>
Collector-base voltage (open emitter)	$V_{CB0}$ max.	300	250 V
Collector-emitter voltage (open base)	$V_{CE0}$ max.	-	250 V
Collector-emitter voltage ( $R_{BE} = 2,7 \text{ kW}$ )	$V_{CER}$ max.	300	- V
Collector current (peak value)	$I_{CM}$ max.	100	mA
Total power dissipation up to $T_{amb} = 25 \text{ }^\circ\text{C}$	$P_{tot}$ max.	250	mW
Junction temperature	$T_j$ max.	150	$^\circ\text{C}$
D.C. current gain	$h_{FE}$	>	50
$I_C = 25 \text{ mA}; V_{CE} = 20 \text{ V}$			
Feedback capacitance at $f = 1 \text{ MHz}$	$C_{re}$	<	1,6 pF
$I_C = 0; V_{CE} = 30 \text{ V}$			
Transition frequency at $f = 35 \text{ MHz}$	$f_T$	>	60 MHz
$I_C = 10\text{mA}; V_{CE} = 10 \text{ V}$			

**BF820**  
**BF822**

**RATINGS** (at  $T_A = 25^\circ\text{C}$  unless otherwise specified)

Limiting values

		<b>BF820</b>	<b>BF822</b>
Collector-base voltage (open emitter)	$V_{CB0}$ max.	300	250 V
Collector-emitter voltage (open base)	$V_{CE0}$ max.	-	250 V
Collector-emitter voltage ( $R_{BE} = 2,7 \text{ kW}$ )	$V_{CER}$ max.	300	— V
Emitter-base voltage (open collector)	$V_{EB0}$ max.	5	V
Collector current (d.c.)	$I_C$ max.	50	mA
Collector current (peak value)	$I_{CM}$ max.	100	mA
Total power dissipation up to $T_{amb} = 25^\circ\text{C}$	$P_{tot}$ max.	250	mW
Storage temperature	$T_{stg}$	-55 to +150	$^\circ\text{C}$
Junction temperature	$T_j$ max.	150	$^\circ\text{C}$

**THERMAL RESISTANCE**

From junction to ambient

$R_{th\ j-a}$	500	KW
---------------	-----	----

**CHARACTERISTICS**

$T_j = 25^\circ\text{C}$  unless otherwise specified

Collector cut-off current

$I_E = 0; V_{CB} = 200 \text{ V}$

	<b>BF820</b>	<b>BF822</b>
$I_{CB0} <$	10	10 nA

Collector-emitter voltage

$R_{BE} = 2,7 \text{ kW}; V_{CE} = 250 \text{ V}$

$I_{CER} <$	50	50 nA
-------------	----	-------

$R_{BE} = 2,7 \text{ kW}; V_{CE} = 200 \text{ V}; T_j = 150^\circ\text{C}$

$I_{CER} <$	10	10 mA
-------------	----	-------

Saturation voltage

$I_C = 30 \text{ mA}; I_B = 5 \text{ mA}$

$V_{CEsat} <$	0,6	V
---------------	-----	---

D.C. current gain

$I_C = 25 \text{ mA}; V_{CE} = 20 \text{ V}$

$h_{FE} >$	50	
------------	----	--

Transition frequency at  $f = 35 \text{ MHz}$

$I_C = 10 \text{ mA}; V_{CE} = 10 \text{ V}$

$f_T >$	60	MHz
---------	----	-----

Feedback capacitance at  $f = 1 \text{ MHz}$

$I_C = 0; V_{CE} = 30 \text{ V}$

$C_{re} <$	1,6	pF
------------	-----	----

### Disclaimer

The product information and the selection guides facilitate selection of the CDIL's Discrete Semiconductor Device(s) best suited for application in your product(s) as per your requirement. It is recommended that you completely review our Data Sheet(s) so as to confirm that the Device(s) meet functionality parameters for your application. The information furnished on the CDIL Web Site/ CD is believed to be accurate and reliable. CDIL however, does not assume responsibility for inaccuracies or incomplete information. Furthermore, CDIL does not assume liability whatsoever, arising out of the application or use of any CDIL product; neither does it convey any license under its patent rights nor rights of others. These products are not designed for use in life saving/support appliances or systems. CDIL customers selling these products (either as individual Discrete Semiconductor Devices or incorporated in their end products), in any life saving/support appliances or systems or applications do so at their own risk and CDIL will not be responsible for any damages resulting from such sale(s).

CDIL strives for continuous improvement and reserves the right to change the specifications of its products without prior notice.



CDIL is a registered Trademark of  
**Continental Device India Limited**

C-120 Naraina Industrial Area, New Delhi 110 028, India.  
Telephone + 91-11-579 6150 Fax + 91-11-579 9569, 579 5290  
e-mail sales@cdil.com www.cdil.com