



**DC COMPONENTS CO., LTD.**

RECTIFIER SPECIALISTS

KBPC / BR  
1005 / 305  
THRU  
KBPC / BR  
110 / 310

**TECHNICAL SPECIFICATIONS OF SINGLE-PHASE SILICON BRIDGE RECTIFIER**

VOLTAGE RANGE - 50 to 1000 Volts

CURRENT - 3.0 Amperes

**FEATURES**

- \* Surge overloa rating: 50 Amperes peak
- \* Low forward voltage drop
- \* Small size: simple installation

**MECHANICAL DATA**

- \* Case: Molded plastic
- \* Epoxy: UL 94V-0 rate flame retardant
- \* Lead: MIL-STD-202E, Method 208 guaranteed  
Symbols molded or marked on body
- \* Mounting position: Any
- \* Weight: 3.36 grams

**MAXIMUM RATINGS AND ELECTRICAL CHARACTERISTICS**

Ratings at 25 °C ambient temperature unless otherwise specified.  
Single phase, half wave, 60 Hz, resistive or inductive load.  
For capacitive load, derate current by 20%.



BR-3

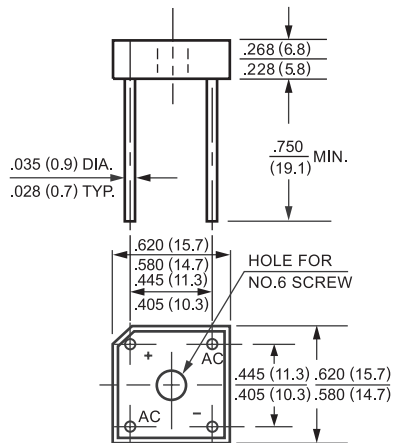

Dimensions in inches and (millimeters)

	SYMBOL	KBPC 1005	KBPC 101	KBPC 102	KBPC 104	KBPC 106	KBPC 108	KBPC 110	UNITS
Maximum Recurrent Peak Reverse Voltage	V <sub>RRM</sub>	50	100	200	400	600	800	1000	Volts
Maximum RMS Bridge Input Voltage	V <sub>RMS</sub>	35	70	140	280	420	560	700	Volts
Maximum DC Blocking Voltage	V <sub>DC</sub>	50	100	200	400	600	800	1000	Volts
Maximum Average Forward Rectified Output Current at T <sub>c</sub> = 50°C	I <sub>O</sub>	3.0							Amps
Peak Forward Surge Current 8.3 ms single half sine-wave superimposed on rated load (JEDEC method)	I <sub>FSM</sub>	50							Amps
Maximum Forward Voltage Drop per element at 1.5A DC	V <sub>F</sub>	1.0							Volts
Maximum CD Reverse Current at Rated	I <sub>R</sub>	@ T <sub>A</sub> = 25°C							uAmps
DC Blocking Voltage per element		@ T <sub>c</sub> = 100°C							
I <sup>2</sup> t Rating for Fusing (t<8.3ms)	I <sup>2</sup> t	10							A <sup>2</sup> Sec
Typical Junction Capacitance ( Note1)	C <sub>J</sub>	21							pF
Operating Temperature Range	T <sub>J</sub>	-55 to + 125							°C
Storage Temperature Range	T <sub>STG</sub>	-55 to + 150							°C

NOTES : 1.Measured at 1 MHz and applied reverse voltage of 4.0 volts

2. Thermal Resistance from Junction to Ambient and from junction to lead mounted on P.C.B. with 0.47 x 0.47" (12x12mm) copper pads.

