

16-Bit, 100 kHz / 20 kHz A/D Converters

Features

- Monolithic CMOS A/D Converters
 - Inherent Sampling Architecture
 - 2-Channel Input Multiplexer
 - Flexible Serial Output Port
- Ultra-Low Distortion
 - S/(N+D): 92 dB
 - THD: 0.001%
- Conversion Time
 - CS5101A: 8 μ s
 - CS5102A: 40 μ s
- Linearity Error: $\pm 0.001\%$ FS
 - Guaranteed No Missing Codes
- Self-Calibration Maintains Accuracy
 - Over Time and Temperature
- Low Power Consumption
 - CS5101A: 320 mW
 - CS5102A: 44 mW
 - Power-down Mode: <1 mW
- Evaluation Board Available

Description

The CS5101A and CS5102A are 16-bit monolithic CMOS analog-to-digital converters capable of 100 kHz (5101A) and 20 kHz (5102A) throughput. The CS5102A's low power consumption of 44 mW, coupled with a power down mode, makes it particularly suitable for battery powered operation.

On-chip self-calibration circuitry achieves nonlinearity of $\pm 0.001\%$ of FS and guarantees 16-bit no missing codes over the entire specified temperature range. Superior linearity also leads to 92 dB S/(N+D) with harmonics below -100 dB. Offset and full-scale errors are minimized during the calibration cycle, eliminating the need for external trimming.

The CS5101A and CS5102A each consist of a 2-channel input multiplexer, DAC, conversion and calibration microcontroller, clock generator, comparator, and serial communications port. The inherent sampling architecture of the device eliminates the need for an external track and hold amplifier.

The converters' 16-bit data is output in serial form with either binary or 2's complement coding. Three output timing modes are available for easy interfacing to microcontrollers and shift registers. Unipolar and bipolar input ranges are digitally selectable.

ORDERING INFORMATION

See page 36.

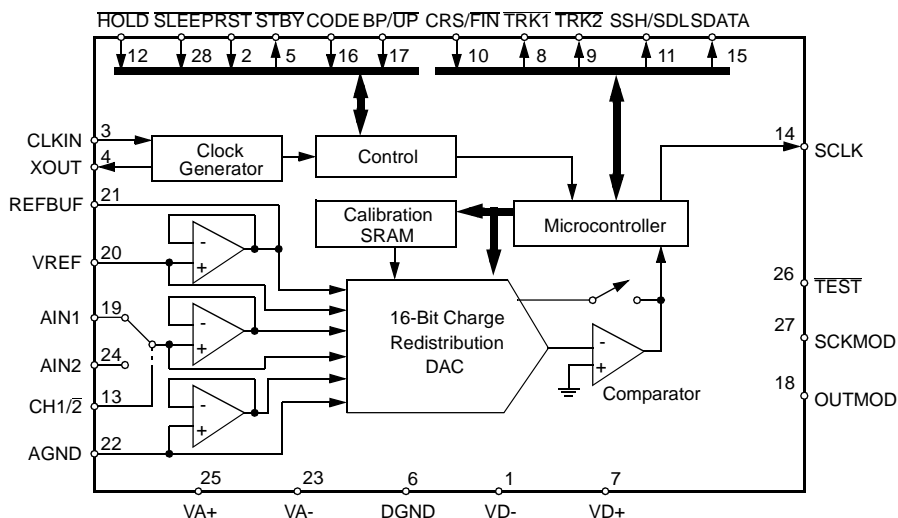

ANALOG CHARACTERISTICS ($T_A = T_{MIN}$ to T_{MAX} ; $V_{A+}, V_{D+} = 5V$; $V_{A-}, V_{D-} = -5V$; $V_{REF} = 4.5V$; Full-Scale Input Sinewave, 1 kHz; $CLKIN = 4$ MHz for -16, 8 MHz for -8; $f_s = 50$ kHz for -16, 100 kHz for -8; Bipolar Mode; FRN Mode; A_{IN1} and A_{IN2} tied together, each channel tested separately; Analog Source Impedance = 50Ω with 1000 pF to AGND unless otherwise specified)

Parameter*	CS5101A-J,K			CS5101A-A,B			Units	
	Min	Typ	Max	Min	Typ	Max		
Specified Temperature Range	0 to +70			-40 to +85			°C	
Accuracy								
Linearity Error	-J,A,S (Note 1)	-	0.002	0.003	-	0.002	0.003	%FS
	-K,B,T	-	0.001	0.002	-	0.001	0.002	%FS
	Drift (Note 2)	-	$\pm 1/4$	-	-	$\pm 1/4$	-	Δ LSB
Differential Linearity	(Notes 3, 4)	16	-	-	16	-	-	Bits
Full Scale Error	-J,A,S (Note 1)	-	± 1	± 4	-	± 1	± 4	LSB
	-K,B,T	-	± 1	± 3	-	± 1	± 3	LSB
	Drift (Note 2)	-	± 1	-	-	± 1	-	Δ LSB
Unipolar Offset	-J,A,S (Note 1)	-	± 2	± 5	-	± 2	± 5	LSB
	-K,B,T	-	± 2	± 4	-	± 2	± 4	LSB
	Drift (Note 2)	-	± 1	-	-	± 1	-	Δ LSB
Bipolar Offset	-J,A,S (Note 1)	-	± 2	± 5	-	± 2	± 5	LSB
	-K,B,T	-	± 2	± 3	-	± 2	± 3	LSB
	Drift (Note 2)	-	± 1	-	-	± 2	-	Δ LSB
Bipolar Negative Full-Scale Error	-J,A,S (Note 1)	-	± 1	± 4	-	± 1	± 4	LSB
	-K,B,T	-	± 1	± 3	-	± 1	± 3	LSB
	Drift (Note 2)	-	± 1	-	-	± 1	-	Δ LSB
Dynamic Performance (Bipolar Mode)								
Peak Harmonic or Spurious Noise (Note 1) 1 kHz Input	-J,A,S	96	100	-	96	100	-	dB
	-K,B,T	98	102	-	98	102	-	dB
12 kHz Input	-J,A,S	85	88	-	85	88	-	dB
	-K,B,T	85	91	-	85	91	-	dB
Total Harmonic Distortion	-J,A,S	-	0.002	-	-	0.002	-	%
	-K,B,T	-	0.001	-	-	0.001	-	%
Signal-to-Noise Ratio (Note 1)	0dB Input	87	90	-	87	90	-	dB
	-K,B,T	90	92	-	90	92	-	dB
	-60 dB Input	-	30	-	-	30	-	dB
	-K,B,T	-	32	-	-	32	-	dB
Noise (Note 5)	Unipolar Mode	-	35	-	-	35	-	μV_{rms}
	Bipolar Mode	-	70	-	-	70	-	μV_{rms}

- Notes: 1. Applies after calibration at any temperature within the specified temperature range. At temp
 2. Total drift over specified temperature range after calibration at power-up at 25 °C.
 3. Minimum resolution for which no missing codes is guaranteed over the specified temperature range.
 4. Clock speeds of less than 1.0 MHz, at temperatures >100°C will degrade DNL performance.
 5. Wideband noise aliased into the baseband. Referred to the input.

*Refer to *Parameter Definitions* (immediately following the pin descriptions at the end of this data sheet).

Specifications are subject to change without notice.

ANALOG CHARACTERISTICS (continued)

Parameter*	Symbol	CS5101A -J,K			CS5101A -A,B			Units
		Min	Typ	Max	Min	Typ	Max	
Specified Temperature Range	-	0 to +70			40 to +85			°C
Analog Input								
Aperture Time	-	-	25	-	-	25	-	ns
Aperture Jitter	-	-	100	-	-	100	-	ps
Input Capacitance (Note 6)								
Unipolar Mode	-	-	320	425	-	320	425	pF
Bipolar Mode	-	-	200	265	-	200	265	pF
Conversion & Throughput								
Conversion Time (Note 7)								
-8	t _c	-	-	8.12	-	-	8.12	μs
-16	t _c	-	-	16.25	-	-	16.25	μs
Acquisition Time (Note 8)								
-8	t _a	-	-	1.88	-	-	1.88	μs
-16	t _a	-	2.6	3.75	-	2.6	3.75	μs
Throughput (Note 9)								
-8	f _{tp}	100	-	-	100	-	-	kHz
-16	f _{tp}	50	-	-	50	-	-	kHz
Power Supplies								
Power Supply Current (Note 10)								
Positive Analog	I _{A+}	-	21	28	-	21	28	mA
Negative Analog	I _{A-}	-	-21	-28	-	-21	-28	mA
(SLEEP High) Positive Digital	I _{D+}	-	11	15	-	11	15	mA
Negative Digital	I _{D-}	-	-11	-15	-	-11	-15	mA
Power Consumption (Notes 10, 11)								
(SLEEP High)	P _{do}	-	320	430	-	320	430	mW
(SLEEP Low)	P _{ds}	-	1	-	-	1	-	mW
Power Supply Rejection: (Note 12)								
Positive Supplies	PSR	-	84	-	-	84	-	dB
Negative Supplies	PSR	-	84	-	-	84	-	dB

- Notes:
- Applies only in the track mode. When converting or calibrating, input capacitance will not exceed 30 pF.
 - Conversion time scales directly to the master clock speed. The times shown are for synchronous, internal loopback (FRN mode) with 8.0 MHz CLKIN. In PDT, RBT, and SSC modes, asynchronous delay between the falling edge of $\overline{\text{HOLD}}$ and the start of conversion may add to the apparent conversion time. This delay will not exceed 1.5 master clock cycles + 10 ns. In PDT, RBT, and SSC modes, CLKIN can be increased as long as the $\overline{\text{HOLD}}$ sample rate is 100 kHz max.
 - The CS5101A requires 6 clock cycles of coarse charge, followed by a minimum of 1.125 μs of fine charge. FRN mode allows 9 clock cycles for fine charge which provides for the minimum 1.125 μs with an 8 MHz clock, however; in PDT, RBT, or SSC modes, at clock frequencies of 8 MHz or less, fine charge may be less than 9 clock cycles. This reflects the typ. specification (6 clock cycles + 1.125 μs).
 - Throughput is the sum of the acquisition and conversion times. It will vary in accordance with conditions affecting acquisition and conversion times, as described above.
 - All outputs unloaded. All inputs at VD+ or DGND.
 - Power consumption in the sleep mode applies with no master clock applied (CLKIN held high or low).
 - With 300 mV p-p, 1 kHz ripple applied to each supply separately in the bipolar mode. Rejection improves by 6 dB in the unipolar mode to 90 dB. Figure 23 shows a plot of typical power supply rejection versus frequency.

SWITCHING CHARACTERISTICS ($T_A = T_{MIN}$ to T_{MAX} ; V_{A+} , $V_{D+} = 5V \pm 10\%$;
 V_{A-} , $V_{D-} = -5V \pm 10\%$; Inputs: Logic 0 = 0V, Logic 1 = V_{D+} ; $C_L = 50$ pF)

Parameter	Symbol	Min	Typ	Max	Units
CLKIN Period (Note 4)	-8 t_{clk}	108	-	10,000	ns
	-16 t_{clk}	250	-	10,000	ns
CLKIN Low Time	t_{ckl}	37.5	-	-	ns
CLKIN High Time	t_{ckh}	37.5	-	-	ns
Crystal Frequency (Note 13)	-8 f_{xtal}	2.0	-	9.216	MHz
	-16 f_{xtal}	2.0	-	4.0	MHz
SLEEP Rising to Oscillator Stable (Note 14)	-	-	2	-	ms
RST Pulse Width	t_{rst}	150	-	-	ns
RST to STBY Falling	t_{drrs}	-	100	-	ns
RST Rising to STBY Rising	t_{cal}	-	11,528,160	-	t_{clk}
CH1/2 Edge to TRK1, TRK2 Rising (Note 15)	t_{drsh1}	-	80	-	ns
CH1/2 Edge to TRK1, TRK2 Falling (Note 15)	t_{dfsh4}	-	-	$68t_{clk}+260$	ns
HOLD to SSH Falling (Note 16)	t_{dfsh2}	-	60		ns
HOLD to TRK1, TRK2, Falling (Note 16)	t_{dfsh1}	$66t_{clk}$	-	$68t_{clk}+260$	ns
HOLD to TRK1, TRK2, SSH Rising (Note 16)	t_{drsh}	-	120	-	ns
HOLD Pulse Width (Note 17)	t_{hold}	$1t_{clk}+20$	-	$63t_{clk}$	ns
HOLD to CH1/2 Edge (Note 16)	t_{dhlri}	15	-	$64t_{clk}$	ns
HOLD Falling to CLKIN Falling (Note 17)	t_{hcf}	95	-	$1t_{clk}+10$	ns

- Notes: 13. External loading capacitors are required to allow the crystal to oscillate. Maximum crystal frequency is 8.0 MHz in FRN mode (100 kHz sample rate).
14. With a 8 MHz crystal, two 10 pF loading capacitors and a 10 M Ω parallel resistor (see Figure 8).
15. These times are for FRN mode.
16. SSH only works correctly if \overline{HOLD} falling edge is within +15 to +30 ns of $CH1/2$ edge or if $CH1/2$ edge occurs after \overline{HOLD} rises to $64 t_{clk}$ after \overline{HOLD} has fallen. These times are for PDT and RBT modes.
17. When \overline{HOLD} goes low, the analog sample is captured immediately. To start conversion, \overline{HOLD} must be latched by a falling edge of CLKIN. Conversion will begin on the next rising edge of CLKIN after \overline{HOLD} is latched. If \overline{HOLD} is operated synchronous to CLKIN, the \overline{HOLD} pulse width may be as narrow as 150 ns for all CLKIN frequencies if CLKIN falls 95 ns after \overline{HOLD} falls. This ensures that the \overline{HOLD} pulse will meet the minimum specification for t_{hcf} .

ANALOG CHARACTERISTICS ($T_A = T_{MIN}$ to T_{MAX} ; $V_{A+}, V_{D+} = 5V$; $V_{A-}, V_{D-} = -5V$;
 $V_{REF} = 4.5V$; Full-Scale Input Sinewave, 200 Hz; $CLKIN = 1.6$ MHz; $f_s = 20$ kHz; Bipolar Mode; FRN Mode;
 AIN1 and AIN2 tied together, each channel tested separately; Analog Source Impedance = 50Ω with 1000pF to
 AGND unless otherwise specified)

Parameter*	CS5102A-J,K			CS5102A-A,B			Units		
	Min	Typ	Max	Min	Typ	Max			
Specified Temperature Range	0 to +70			-40 to +85			°C		
Accuracy									
Linearity Error	-J,A,S (Note 1)	-	0.002	0.003	-	0.002	0.003	%FS	
	-K,B,T	-	0.001	0.0015	-	0.001	0.0015	%FS	
	Drift (Note 2)	-	$\pm 1/4$	-	-	$\pm 1/4$	-	Δ LSB	
Differential Linearity	(Notes 3, 18)	16	-	-	16	-	-	Bits	
Full Scale Error	-J,A,S (Note 1)	-	± 2	± 4	-	± 2	± 4	LSB	
	-K,B,T	-	± 2	± 3	-	± 2	± 3	LSB	
	Drift (Note 2)	-	± 1	-	-	± 1	-	Δ LSB	
Unipolar Offset	-J,A,S (Note 1)	-	± 1	± 4	-	± 1	± 4	LSB	
	-K,B,T	-	± 1	± 3	-	± 1	± 3	LSB	
	Drift (Note 2)	-	± 1	-	-	± 1	-	Δ LSB	
Bipolar Offset	-J,A,S (Note 1)	-	± 1	± 4	-	± 1	± 4	LSB	
	-K,B,T	-	± 1	± 3	-	± 1	± 3	LSB	
	Drift (Note 2)	-	± 1	-	-	± 2	-	Δ LSB	
Bipolar Negative Full-Scale Error	-J,A,S (Note 1)	-	± 2	± 4	-	± 2	± 4	LSB	
	-K,B,T	-	± 2	± 3	-	± 2	± 3	LSB	
	Drift (Note 2)	-	± 1	-	-	± 2	-	Δ LSB	
Dynamic Performance (Bipolar Mode)									
Peak Harmonic or Spurious Noise	-J,A,S (Note 1)	96	100	-	96	100	-	dB	
	-K,B,T	98	102	-	98	102	-	dB	
Total Harmonic Distortion	-J,A,S	-	0.002	-	-	0.002	-	%	
	-K,B,T	-	0.001	-	-	0.001	-	%	
Signal-to-Noise Ratio	(Note 1)								
	0dB Input	-J,A,S	87	90	-	87	90	-	dB
		-K,B,T	90	92	-	90	92	-	dB
	-60 dB Input	-J,A,S	-	30	-	-	30	-	dB
		-K,B,T	-	32	-	-	32	-	dB
Noise	(Note 5)								
	Unipolar Mode	-	35	-	-	35	-	μV_{rms}	
	Bipolar Mode	-	70	-	-	70	-	μV_{rms}	

Note: 18. Clock speeds of less than 1.6 MHz, at temperatures $>100^\circ C$ will degrade DNL performance.

*Refer to *Parameter Definitions* (immediately following the pin descriptions at the end of this data sheet).

Specifications are subject to change without notice.

ANALOG CHARACTERISTICS (continued)

Parameter*	Symbol	CS5102A -J,K			CS5102A -A,B			Units	
		Min	Typ	Max	Min	Typ	Max		
Specified Temperature Range	-	0 to +70			40 to +85			°C	
Analog Input									
Aperture Time	-	-	30	-	-	30	-	ns	
Aperture Jitter	-	-	100	-	-	100	-	ps	
Input Capacitance (Note 6)	-	-	320	425	-	320	425	pF	
	-	-	200	265	-	200	265	pF	
Conversion & Throughput									
Conversion Time (Note 19)	t _c	-	-	40.625	-	-	40.625	μs	
Acquisition Time (Note 20)	t _a	-	-	9.375	-	-	9.375	μs	
Throughput (Note 21)	f _{tp}	20	-	-	20	-	-	kHz	
Power Supplies									
Power Supply Current (Note 22) (SLEEP High)	Positive Analog	I _{A+}	-	2.4	3.5	-	2.4	3.5	mA
	Negative Analog	I _{A-}	-	-2.4	-3.5	-	-2.4	-3.5	mA
	Positive Digital	I _{D+}	-	2.5	3.5	-	2.5	3.5	mA
	Negative Digital	I _{D-}	-	-1.5	-2.5	-	-1.5	-2.5	mA
Power Consumption (Notes 11, 22) (SLEEP High)	P _{do}	-	44	65	-	44	65	mW	
	(SLEEP Low)	P _{ds}	-	1	-	-	1	-	mW
Power Supply Rejection: (Note 23)	Positive Supplies	PSR	-	84	-	-	84	-	dB
	Negative Supplies	PSR	-	84	-	-	84	-	dB

- Notes: 19. Conversion time scales directly to the master clock speed. The times shown are for synchronous, internal loopback (FRN mode). In PDT, RBT, and SSC modes, asynchronous delay between the falling edge of $\overline{\text{HOLD}}$ and the start of conversion may add to the apparent conversion time. This delay will not exceed 1 master clock cycle + 140 ns.
20. The CS5102A requires 6 clock cycles of coarse charge, followed by a minimum of 5.625 μs of fine charge. FRN mode allows 9 clock cycles for fine charge which provides for the minimum 5.625 μs with an 1.6 MHz clock, however; in PDT, RBT, or SSC modes, at clock frequencies less than 1.6 MHz, fine charge may be less than 9 clock cycles.
21. Throughput is the sum of the acquisition and conversion times. It will vary in accordance with conditions affecting acquisition and conversion times, as described above.
22. All outputs unloaded. All inputs at VD+ or DGND. See table below for power dissipation vs. clock frequency.
23. With 300 mV p-p, 1 kHz ripple applied to each supply separately in the bipolar mode. Rejection improves by 6 dB in the unipolar mode to 90 dB. Figure 23 shows a plot of typical power supply rejection versus frequency.

Typ. Power (mW)	CLKIN (MHz)
34	0.8
37	1.0
39	1.2
41	1.4
44	1.6

SWITCHING CHARACTERISTICS ($T_A = T_{MIN}$ to T_{MAX} ;
 $V_{A+}, V_{D+} = 5V \pm 10\%$; $V_{A-}, V_{D-} = -5V \pm 10\%$; Inputs: Logic 0 = 0V, Logic 1 = V_{D+} ; $C_L = 50$ pF)

Parameter	Symbol	Min	Typ	Max	Units
CLKIN Period (Note 18,24)	t_{clk}	0.5	-	10	μs
CLKIN Low Time	t_{ckl}	200	-	-	ns
CLKIN High Time	t_{ckh}	200	-	-	ns
Crystal Frequency (Note 24, 25)	f_{xtal}	0.9	1.6	2.0	MHz
SLEEP Rising to Oscillator Stable (Note 26)	-	-	20	-	ms
RST Pulse Width	t_{rst}	150	-	-	ns
RST to STBY Falling	t_{drrs}	-	100	-	ns
RST Rising to STBY Rising	t_{cal}	-	2,882,040	-	t_{clk}
CH1/2 Edge to TRK1, TRK2 Rising (Note 27)	t_{drsh1}	-	80	-	ns
CH1/2 Edge to TRK1, TRK2 Falling (Note 27)	t_{dfsh4}	-	-	$68t_{clk}+260$	ns
HOLD to SSH Falling (Note 28)	t_{dfsh2}	-	60	-	ns
HOLD to TRK1, TRK2, Falling (Note 28)	t_{dfsh1}	$66t_{clk}$	-	$68t_{clk}+260$	ns
HOLD to TRK1, TRK2, SSH Rising (Note 28)	t_{drsh}	-	120	-	ns
HOLD Pulse Width (Note 29)	t_{hold}	$1t_{clk}+20$	-	$63t_{clk}$	ns
HOLD to CH1/2 Edge (Note 28)	t_{dhlri}	15	-	$64t_{clk}$	ns
HOLD Falling to CLKIN Falling (Note 29)	t_{hcf}	55	-	$1t_{clk}+10$	ns

- Note: 24. Minimum CLKIN period is 0.625 μs in FRN mode (20 kHz sample rate). At temperatures $>+85$ °C, and with clock frequencies <1.6 MHz, analog performance may be degraded.
25. External loading capacitors are required to allow the crystal to oscillate. Maximum crystal frequency is 1.6 MHz in FRN mode (20 kHz sample rate).
26. With a 2.0 MHz crystal, two 33 pF loading capacitors and a 10 M Ω parallel resistor (see Figure 8).
27. These times are for FRN mode.
28. SSH only works correctly if \overline{HOLD} falling edge is within +15 to +30 ns of $CH1/2$ edge or if $CH1/2$ edge occurs after \overline{HOLD} rises to $64 t_{clk}$ after \overline{HOLD} has fallen. These times are for PDT and RBT modes.
29. When \overline{HOLD} goes low, the analog sample is captured immediately. To start conversion, \overline{HOLD} must be latched by a falling edge of CLKIN. Conversion will begin on the next rising edge of CLKIN after \overline{HOLD} is latched. If \overline{HOLD} is operated synchronous to CLKIN, the \overline{HOLD} pulse width may be as narrow as 150 ns for all CLKIN frequencies if CLKIN falls 55 ns after \overline{HOLD} falls. This ensures that the \overline{HOLD} pulse will meet the minimum specification for t_{hcf} .

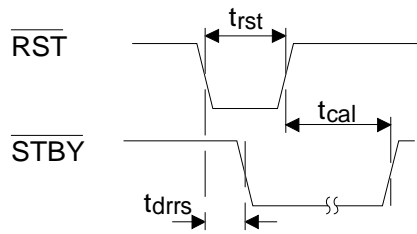

Reset and Calibration Timing

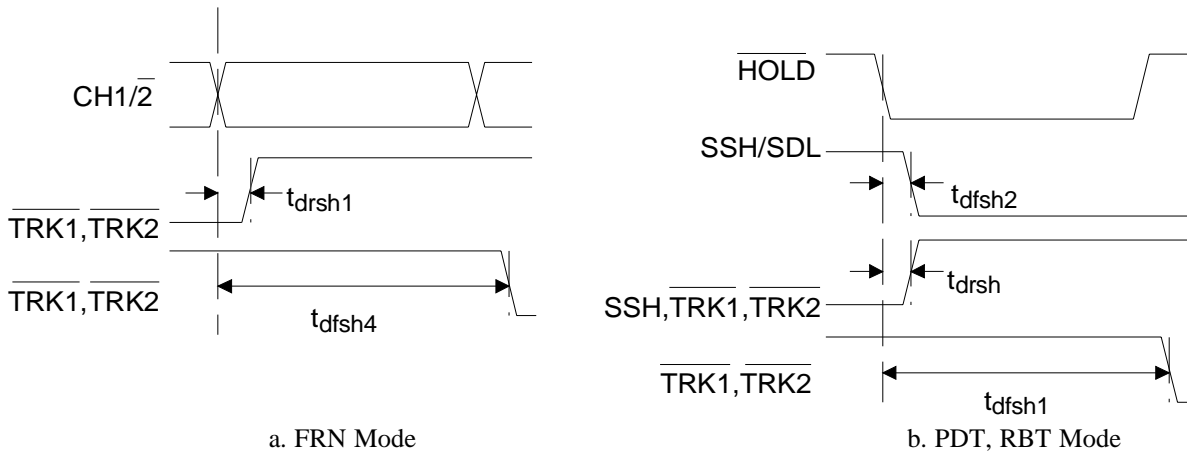

Control Output Timing



Channel Selection Timing

Start Conversion Timing

SWITCHING CHARACTERISTICS (Continued)

Parameter	Symbol	Min	Typ	Max	Units
PDT and RBT Modes					
SCLK Input Pulse Period	t_{sclk}	200	-	-	ns
SCLK Input Pulse Width Low	t_{sckl}	50	-	-	ns
SCLK Input Pulse Width High	t_{sckh}	50	-	-	ns
SCLK Input Falling to SDATA Valid	t_{dss}	-	100	150	ns
HOLD Falling to SDATA Valid	PDT Mode t_{dhs}	-	140	230	ns
TRK1, TRK2 Falling to SDATA Valid	(Note 30) t_{dts}	-	65	125	ns
FRN and SSC Modes					
SCLK Output Pulse Width Low	t_{slkl}	-	$2t_{clk}$	-	t_{clk}
SCLK Output Pulse Width High	t_{slkh}	-	$2t_{clk}$	-	t_{clk}
SDATA Valid Before Rising SCLK	t_{ss}	$2t_{clk}-100$	-	-	ns
SDATA Valid After Rising SCLK	t_{sh}	$2t_{clk}-100$	-	-	ns
SDL Falling to 1st Rising SCLK	t_{rsclk}	-	$2t_{clk}$	-	ns
Last Rising SCLK to SDL Rising	CS5101A CS5102A t_{rsdl}	-	$2t_{clk}$ $2t_{clk}$	$2t_{clk}+165$ $2t_{clk}+200$	ns ns
HOLD Falling to 1st Falling SCLK	CS5101A CS5102A t_{hfs}	$6t_{clk}$ $6t_{clk}$	-	$8t_{clk}+165$ $8t_{clk}+200$	ns ns
CH1/2 Edge to 1st Falling SCLK	t_{chfs}	-	$7t_{clk}$	-	t_{clk}

Note: 30. Only valid for $\overline{TRK1}$, $\overline{TRK2}$ falling when SCLK is low. If SCLK is high when $\overline{TRK1}$, $\overline{TRK2}$ falls, then SDATA is valid t_{dss} time after the next falling SCLK.

DIGITAL CHARACTERISTICS ($T_A = T_{min}$ to T_{max} ; V_{A+} , $V_{D+} = 5V \pm 10\%$; V_{A-} , $V_{D-} = -5V \pm 10\%$)

Parameter	Symbol	Min	Typ	Max	Units
Calibration Memory Retention Power Supply Voltage V_{A+} and V_{D+}	(Note 31) V_{MR}	2.0	-	-	V
High-Level Input Voltage	V_{IH}	2.0	-	-	V
Low-Level Input Voltage	V_{IL}	-	-	0.8	V
High-Level Output Voltage	(Note 32) V_{OH}	$(V_{D+})-1.0$	-	-	V
Low-Level Output Voltage	$I_{OUT} = 1.6$ mA V_{OL}	-	-	0.4	V
Input Leakage Current	I_{in}	-	-	10	μA
Digital Output Pin Capacitance	C_{out}	-	9	-	pF

Notes: 31. V_{A-} and V_{D-} can be any value from zero to -5V for memory retention. Neither V_{A-} or V_{D-} should be allowed to go positive. A_{IN1} , A_{IN2} or V_{REF} must not be greater than V_{A+} or V_{D+} .

This parameter is guaranteed by characterization.

32. $I_{OUT} = -100 \mu A$. This specification guarantees TTL compatibility ($V_{OH} = 2.4V$ @ $I_{out} = -40 \mu A$).

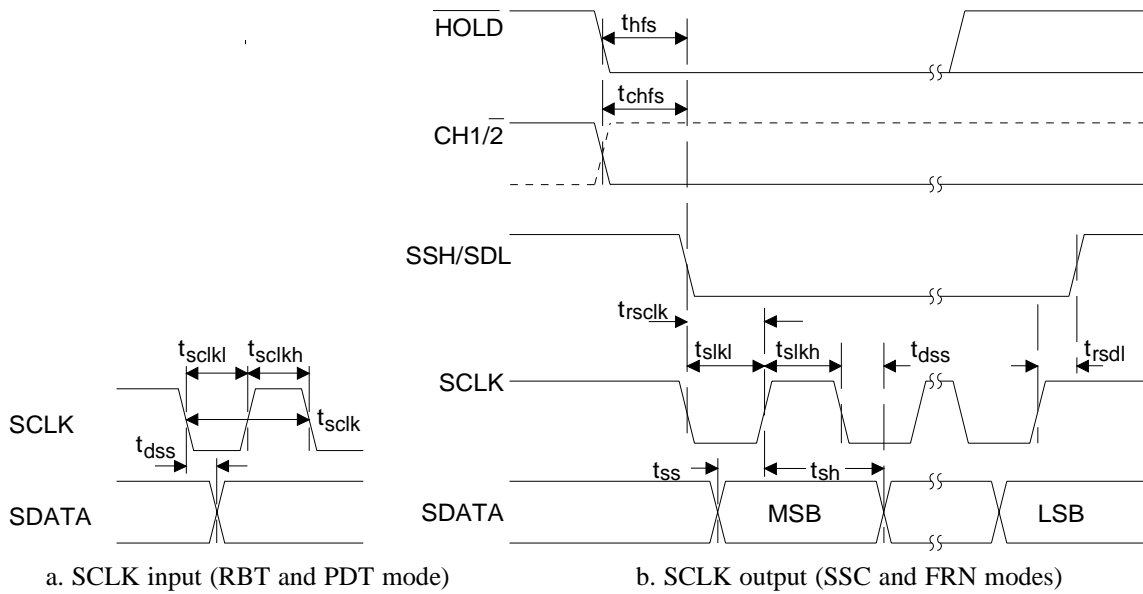

Serial Data Timing

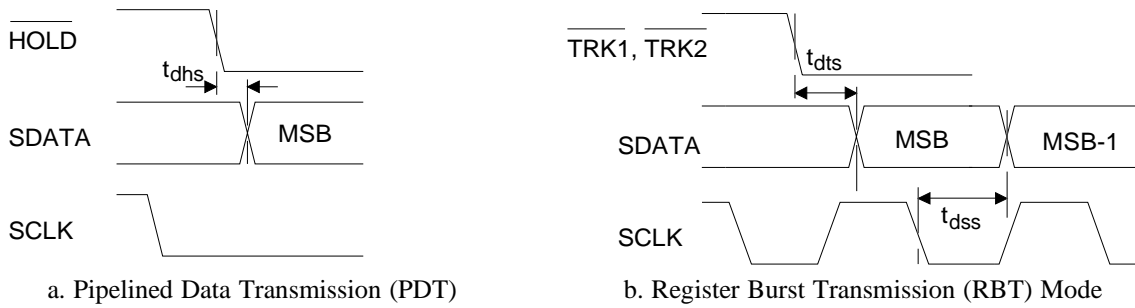

Data Transmission Timing

RECOMMENDED OPERATING CONDITIONS (AGND, DGND = 0V, see Note 33)

Parameter		Symbol	Min	Typ	Max	Units
DC Power Supplies:	Positive Digital	VD+	4.5	5.0	VA+	V
	Negative Digital	VD-	-4.5	-5.0	-5.5	V
	Positive Analog	VA+	4.5	5.0	5.5	V
	Negative Analog	VA-	-4.5	-5.0	-5.5	V
Analog Reference Voltage		VREF	2.5	4.5	(VA+)-0.5	V
Analog Input Voltage: (Note 34)						
	Unipolar	V _{AIN}	AGND	-	VREF	V
	Bipolar	V _{AIN}	-VREF	-	VREF	V

Notes: 33. All voltages with respect to ground.

34. The CS5101A and CS5102A can accept input voltages up to the analog supplies (VA+ and VA-). They will produce an output of all 1's for inputs above VREF and all 0's for inputs below AGND in unipolar mode and -VREF in bipolar mode, with binary coding (CODE = low).

ABSOLUTE MAXIMUM RATINGS* (AGND, DGND = 0V, all voltages with respect to ground)

Parameter		Symbol	Min	Typ	Max	Units
DC Power Supplies:	Positive Digital (Note 35)	VD+	-0.3	-	6.0	V
	Negative Digital	VD-	0.3	-	-6.0	V
	Positive Analog	VA+	-0.3	-	6.0	V
	Negative Analog	VA-	0.3	-	-6.0	V
Input Current, Any Pin Except Supplies (Note 36)		I _{in}	-	-	±10	mA
Analog Input Voltage (AIN and VREF pins)		V _{INA}	(VA-)-0.3	-	(VA+)+0.3	V
Digital Input Voltage		V _{IND}	-0.3	-	(VA+)+0.3	V
Ambient Operating Temperature		T _A	-55	-	125	°C
Storage Temperature		T _{stg}	-65	-	150	°C
Ambient Operating Temperature		T _A	-55	-	125	°C
Storage Temperature		T _{stg}	-65	-	150	°C

Notes: 35. In addition, VD+ must not be greater than (VA+) +0.3V

36. Transient currents of up to 100 mA will not cause SCR latch-up.

*WARNING: Operation beyond these limits may result in permanent damage to the device.

GENERAL DESCRIPTION

The CS5101A and CS5102A are 2-channel, 16-bit A/D converters. The devices include an inherent sample/hold and an on-chip analog switch for 2-channel operation. Both channels can thus be sampled and converted at rates up to 50 kHz each (CS5101A) or 10 kHz each (CS5102A). Alternatively, each of the devices can be operated as a single channel ADC operating at 100 kHz (CS5101A) or 20 kHz (CS5102A).

Both the CS5101A and CS5102A can be configured to accept either unipolar or bipolar input ranges, and data is output serially in either binary or 2's complement coding. The devices can be configured in 3 different output modes, as well as an internal, synchronous loopback mode. The CS5101A and CS5102A provide coarse charge/fine charge control, to allow accurate tracking of high-slew signals.

THEORY OF OPERATION

The CS5101A and CS5102A implement the successive approximation algorithm using a charge redistribution architecture. Instead of the traditional resistor network, the DAC is an array of binary-weighted capacitors. All capacitors in the

array share a common node at the comparator's input. As shown in Figure 1, their other terminals are capable of being connected to AGND, VREF, or AIN (1 or 2). When the device is not calibrating or converting, all capacitors are tied to AIN. Switch S1 is closed and the charge on the array, tracks the input signal.

When the conversion command is issued, switch S1 opens. This traps the charge on the comparator side of the capacitor array and creates a floating node at the comparator's input. The conversion algorithm operates on this fixed charge, and the signal at the analog input pin is ignored. In effect, the entire DAC capacitor array serves as analog memory during conversion much like a hold capacitor in a sample/hold amplifier.

The conversion consists of manipulating the free plates of the capacitor array to VREF and AGND to form a capacitive divider. Since the charge at the floating node remains fixed, the voltage at that point depends on the proportion of capacitance tied to VREF versus AGND. The successive-approximation algorithm is used to find the proportion of capacitance, which when connected to the reference will drive the voltage at the floating node to zero. That binary fraction of capacitance represents the converter's digital output.

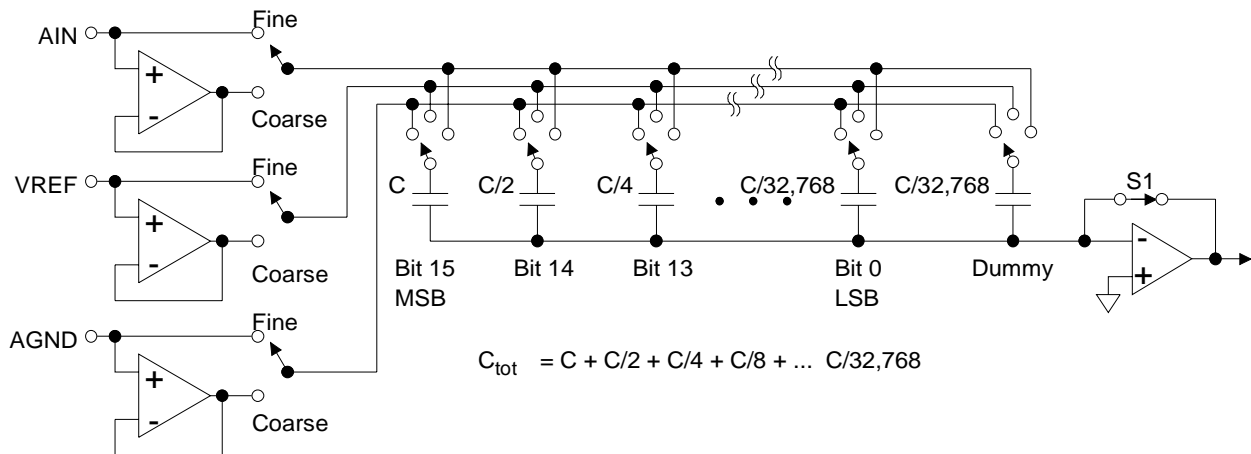

Figure 1. Coarse Charge Input Buffers and Charge Redistribution DAC

Calibration

The ability of the CS5101A or the CS5102A to convert accurately to 16-bits clearly depends on the accuracy of its comparator and DAC. Each device utilizes an "auto-zeroing" scheme to null errors introduced by the comparator. All offsets are stored on the capacitor array while in the track mode and are effectively subtracted from the input signal when a conversion is initiated. Auto-zeroing enhances power supply rejection at frequencies well below the conversion rate.

To achieve 16-bit accuracy from the DAC, the CS5101A and CS5102A use a novel self-calibration scheme. Each bit capacitor shown in Figure 1 actually consists of several capacitors in parallel which can be manipulated to adjust the overall bit weight. An on-chip micro controller precisely adjusts each capacitor with a resolution of 18 bits.

The CS5101A and CS5102A should be reset upon power-up, thus initiating a calibration cycle. The device then stores its calibration coefficients in on-chip SRAM. When the CS5101A and CS5102A are in power-down mode (SLEEP low), they retain the calibration coefficients in memory, and need not be recalibrated when normal operation is resumed.

OPERATION OVERVIEW

Monolithic design and inherent sampling architecture make the CS5101A and CS5102A extremely easy to use.

Initiating Conversions

A falling transition on the $\overline{\text{HOLD}}$ pin places the input in the hold mode and initiates a conversion cycle. The charge is trapped on the capacitor array the instant $\overline{\text{HOLD}}$ goes low. The device will complete conversion of the sample within 66 master clock cycles, then automatically return to

the track mode. After allowing a short time for acquisition, the device will be ready for another conversion.

In contrast to systems with separate track-and-holds and A/D converters, a sampling clock can simply be connected to the $\overline{\text{HOLD}}$ input. The duty cycle of this clock is not critical. The $\overline{\text{HOLD}}$ input is latched internally by the master clock, so it need only remain low for $1/f_{\text{clk}} + 20 \text{ ns}$, but no longer than the minimum conversion time minus two master clocks or an additional conversion cycle will be initiated with inadequate time for acquisition. In Free Run mode, $\text{SCKMOD} = \text{OUTMOD} = 0$, the device will convert at a rate of $\text{CLKIN}/80$, and the $\overline{\text{HOLD}}$ input is ignored.

As with any high-resolution A-to-D system, it is recommended that sampling is synchronized to the master system clock in order to minimize the effects of clock feedthrough. However, the CS5101A and CS5102A may be operated entirely asynchronous to the master clock if necessary.

Tracking the Input

Upon completing a conversion cycle the CS5101A and CS5102A immediately return to the track mode. The $\text{CH1}/\overline{2}$ pin directly controls the input switch, and therefore directly determines which channel will be tracked. Ideally, the $\text{CH1}/\overline{2}$ pin should be switched during the conversion cycle, thereby nullifying the input mux switching time, and guaranteeing a stable input at the start of acquisition. If, however, the $\text{CH1}/\overline{2}$ control is changed during the acquisition phase, adequate coarse charge and fine charge time must be allowed before initiating conversion.

When the CS5101A or the CS5102A enters tracking mode, it uses an internal input buffer amplifier to provide the bulk of the charge on the capacitor array (coarse-charge), thereby reducing the current load on the external analog circuitry. Coarse-charge is internally initiated for 6 clock cycles at the end of every conversion. The buffer

amplifier is then bypassed, and the capacitor array is directly connected to the input. This is referred to as fine-charge, during which the charge on the array is allowed to accurately settle to the input voltage (see Figure 10).

With a full scale input step, the coarse-charge input buffer of the CS5101A will charge the capacitor array within 1% in 650 ns. The converter timing allows 6 clock cycles for coarse charge settling time. When the CS5101A switches to fine-charge mode, its slew rate is somewhat reduced. In fine-charge, the CS5101A can slew at 2 V/ μ s in unipolar mode. In bipolar mode, only half the capacitor array is connected to the analog input, so the CS5101A can slew at 4V/ μ s.

With a full scale input step, the coarse-charge input buffer of the CS5102A will charge the capacitor array within 1% in 3.75 μ s. The converter timing allows 6 clock cycles for coarse charge settling time. When in fine-charge mode, the CS5102A can slew at 0.4 V/ μ s in unipolar mode; and at 0.8 V/ μ s in bipolar mode.

Acquisition of fast slewing signals can be hastened if the voltage change occurs during or immediately following the conversion cycle. For instance, in multiple channel applications (using either the device's internal channel selector or an external MUX), channel selection should occur while the CS5101A or the CS5102A is converting. Multiplexer switching and settling time is thereby removed from the overall throughput equation.

If the input signal changes drastically during the acquisition period (such as changing the signal source), the device should be in coarse-charge for an adequate period following the change. The CS5101A and CS5102A can be forced into coarse-charge by bringing $\overline{\text{CRS}/\overline{\text{FIN}}}$ high. The buffer amplifier is engaged when $\overline{\text{CRS}/\overline{\text{FIN}}}$ is high, and may be switched in any number of

times during tracking. If $\overline{\text{CRS}/\overline{\text{FIN}}}$ is held low, the CS5101A and CS5102A will only coarse-charge for the first 6 clock cycles following a conversion, and will stay in fine-charge until $\overline{\text{HOLD}}$ goes low. To get an accurate sample using the CS5101A, at least 750 ns of coarse-charge, followed by 1.125 μ s of fine-charge is required before initiating a conversion. If coarse charge is not invoked, then up to 25 μ s should be allowed after a step change input for proper acquisition. To get an accurate sample using the CS5102A, at least 3.75 μ s of coarse-charge, followed by 5.625 μ s of fine-charge is required before initiating a conversion (see Figure 2). If coarse charge is not invoked, then up to 125 μ s should be allowed after a step change input for proper acquisition. The $\overline{\text{CRS}/\overline{\text{FIN}}}$ pin must be low prior to $\overline{\text{HOLD}}$ becoming active and be held low during conversion.

Master Clock

The CS5101A and CS5102A can operate either from an externally-supplied master clock, or from their own crystal oscillator (with a crystal). To enable the internal crystal oscillator, simply tie a crystal across the XOUT and CLKIN pins and add 2 capacitors and a resistor, as shown on the system connection diagram in Figure 8.

Calibration and conversion times directly scale to the master clock frequency. The CS5101A-8 can operate with clock or crystal frequencies up to 9.216 MHz (8.0 MHz in FRN mode). This allows maximum throughput of up to 50 kHz per channel in dual-channel operation, or 100 kHz in a single channel configuration. The CS5101A-16 can accept a maximum clock speed of 4 MHz, with corresponding throughput of 50 kHz. The CS5102A can operate with clock or crystal frequencies up to 2.0 MHz (1.6 MHz in FRN mode). This allows maximum throughput of up to 10 kHz per channel in dual-channel operation, or 20 kHz in a single channel configuration. For 16 bit performance a 1.6 MHz clock is recommended. This 1.6 MHz

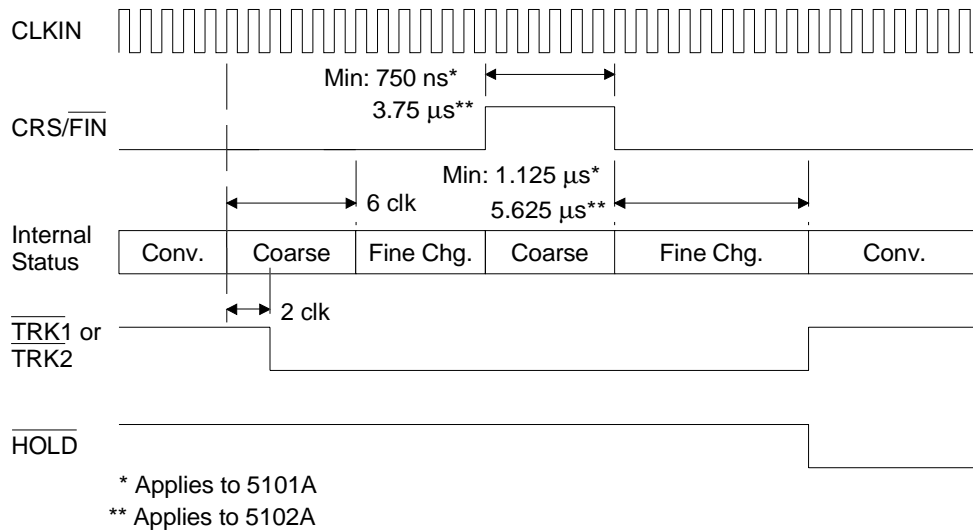

Figure 2. Coarse-Charge/Fine-Charge Control

clock yields a maximum throughput of 20 kHz in a single channel configuration.

Asynchronous Sampling Considerations

When $\overline{\text{HOLD}}$ goes low, the analog sample is captured immediately. The $\overline{\text{HOLD}}$ signal is latched by the next falling edge of CLKIN, and conversion then starts on the subsequent rising edge. If $\overline{\text{HOLD}}$ is asynchronous to CLKIN, then there will be a 1.5 CLKIN cycle uncertainty as to when conversion starts. Considering the CS5101A with an 8 MHz CLKIN, with a 100 kHz $\overline{\text{HOLD}}$ signal, then this 1.5 CLKIN uncertainty will result in a 1.5 CLKIN period possible reduction in fine charge time for the next conversion.

Unipolar Input Voltage	Offset Binary	Two's Complement	Bipolar Input Voltage
$>(\text{VREF}-1.5 \text{ LSB})$	FFFF	7FFF	$>(\text{VREF}-1.5 \text{ LSB})$
VREF-1.5 LSB	FFFF FFFE	7FFF 7FFE	VREF-1.5 LSB
VREF/2-0.5 LSB	8000 7FFF	0000 FFFF	-0.5 LSB
+0.5 LSB	0001 0000	8001 8000	$-\text{VREF}+0.5 \text{ LSB}$
$<(+0.5 \text{ LSB})$	0000	8000	$<(-\text{VREF}+0.5 \text{ LSB})$

Table 1. Output Coding

This reduced fine charge time will be less than the minimum specification. If the CLKIN frequency is increased slightly (for example, to 8.192 MHz) then sufficient fine charge time will always occur. The maximum frequency for CLKIN is specified at 9.216 MHz; it is recommended that for asynchronous operation at 100 kHz, CLKIN should be between 8.192 MHz and 9.216 MHz.

Analog Input Range/Coding Format

The reference voltage directly defines the input voltage range in both the unipolar and bipolar configurations. In the unipolar configuration (BP/UP low), the first code transition occurs 0.5 LSB above AGND, and the final code transition occurs 1.5 LSB's below VREF. In the bipolar configuration (BP/UP high), the first code transition occurs 0.5 LSB above -VREF and the last transition occurs 1.5 LSB's below +VREF.

The CS5101A and CS5102A can output data in either 2's complement, or binary format. If the CODE pin is high, the output is in 2's complement format with a range of -32,768 to +32,767. If the CODE pin is low, the output is in binary format with a range of 0 to +65,535. See Table 1 for output coding.

MODE	SCKMOD	OUTMOD	SCLK	CH1/2	HOLD
PDT	1	1	Input	Input	Input
RBT	1	0	Input	Input	Input
SSC	0	1	Output	Input	Input
FRN	0	0	Output	Output	X

Table 2. Serial Output Modes

Output Mode Control

The CS5101A and CS5102A can be configured in three different output modes, as well as an internal, synchronous loop-back mode. This allows great flexibility for design into a wide variety of systems. The operating mode is selected by setting the states of the SCKMOD and OUTMOD pins. In all modes, data is output on SDATA, starting with the MSB. Each subsequent data bit is updated on the falling edge of SCLK.

When SCKMOD is high, SCLK is an input, allowing the data to be clocked out with an external serial clock at rates up to 5 MHz. Additional clock edges after #16 will clock out logic '1's on SDATA. Tying SCKMOD low reconfigures SCLK as an output, and the converter clocks

out each bit as it's determined during the conversion process, at a rate of 1/4 the master clock speed. Table 2 shows an overview of the different states of SCKMOD and OUTMOD, and the corresponding output modes.

Pipelined Data Transmission (PDT)

PDT mode is selected by tying both SCKMOD and OUTMOD high. In PDT mode, the SCLK pin is an input. Data is registered during conversion, and output during the following conversion cycle. HOLD must be brought low, initiating another conversion, before data from the previous conversion is available on SDATA. If all the data has not been clocked out before the next falling edge of HOLD, the old data will be lost (Figure 3).

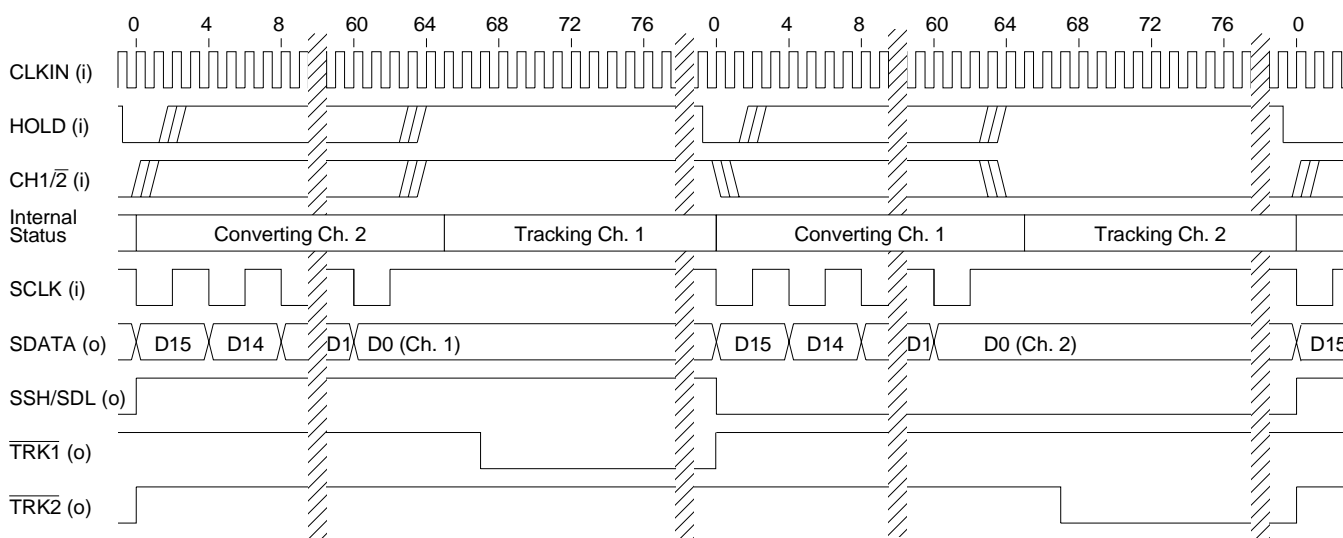

Figure 3. Pipelined Data Transmission Mode (PDT)

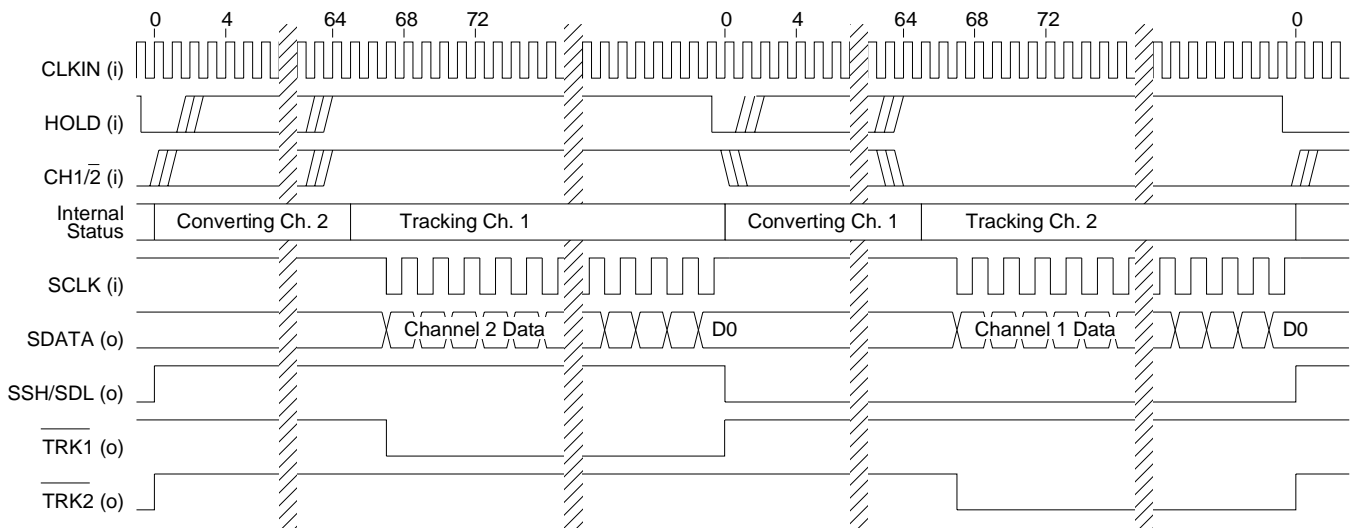

Figure 4. Registered Burst Transmission Mode (RBT)

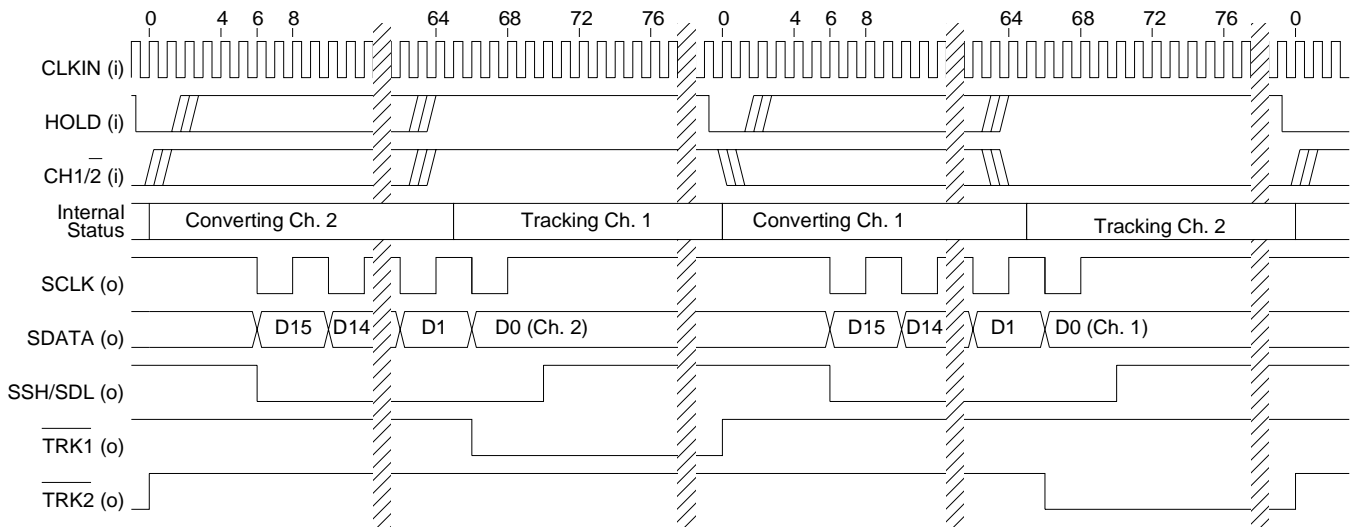

Figure 5. Synchronous Self-Clocking Mode (SSC)

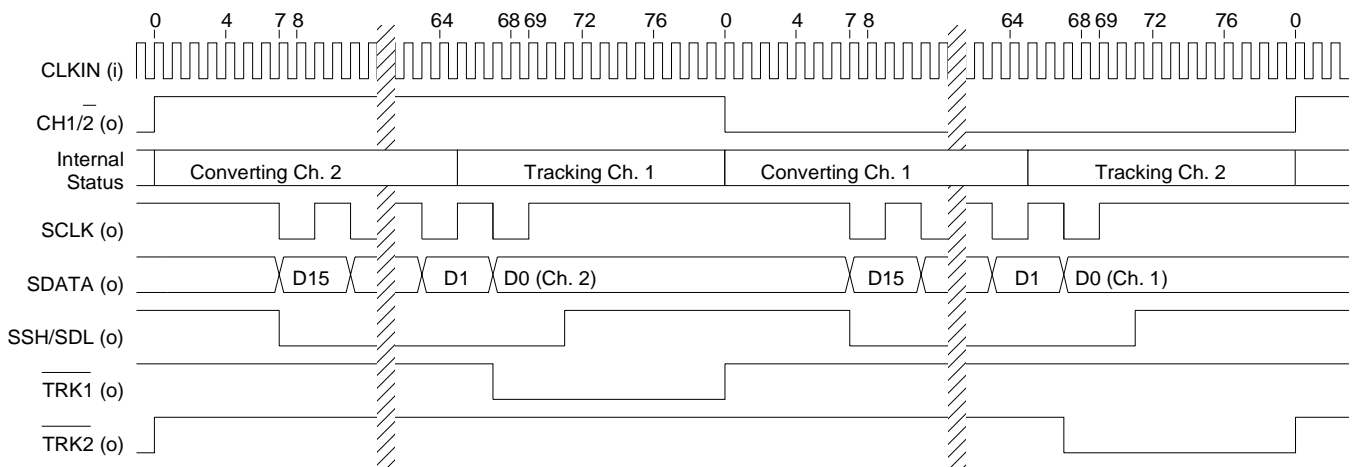

Figure 6. Free Run Mode (FRN)

Registered Burst Transmission (RBT)

RBT mode is selected by tying SCKMOD high, and OUTMOD low. As in PDT mode, SCLK is an input, however data is available immediately following conversion, and may be clocked out the moment $\overline{\text{TRK1}}$ or $\overline{\text{TRK2}}$ falls. The falling edge of $\overline{\text{HOLD}}$ clears the output buffer, so any unread data will be lost. A new conversion may be initiated before all the data has been clocked out if the unread data bits are not important (Figure 4).

Synchronous Self-Clocking (SSC)

SSC mode is selected by tying SCKMOD low, and OUTMOD high. In SSC mode, SCLK is an output, and will clock out each bit of the data as it's being converted. SCLK will remain high between conversions, and run at a rate of 1/4 the master clock speed for 16 low pulses during conversion (Figure 5).

The SSH/SDL goes low coincident with the first falling edge of SCLK, and returns high 2 CLKIN cycles after the last rising edge of SCLK. This signal frames the 16 data bits and is useful for interfacing to shift registers (e.g. 74HC595) or to DSP serial ports.

Free Run (FRN)

Free Run is the internal, synchronous loopback mode. FRN mode is selected by tying SCKMOD and OUTMOD low. SCLK is an output, and operates exactly the same as in the SSC mode. In Free Run mode, the converter initiates a new conversion every 80 master clock cycles, and alternates between channel 1 and channel 2. $\overline{\text{HOLD}}$ is disabled, and should be tied to either VD+ or DGND. $\text{CH1}/\overline{2}$ is an output, and will change at the start of each new conversion cycle, indicating which channel will be tracked after the current conversion is finished (Figure 6).

The SSH/SDL goes low coincident with the first falling edge of SCLK, and returns high 2 CLKIN cycles after the last rising edge of SCLK. This signal frames the 16 data bits and is useful for interfacing to shift registers (e.g. 74HC595) or to DSP serial ports.

SYSTEM DESIGN WITH THE CS5101A AND CS5102A

Figure 7 shows a general system connection diagram for the CS5101A and CS5102A.

Digital Circuit Connections

When TTL loads are utilized the potential for crosstalk between digital and analog sections of the system is increased. This crosstalk is due to high digital supply and signal currents arising from the TTL drive current required of each digital output. Connecting CMOS logic to the digital outputs is recommended. Suitable logic families include 4000B, 74HC, 74AC, 74ACT, and 74HCT.

System Initialization

Upon power up, the CS5101A and CS5102A must be reset to guarantee a consistent starting condition and initially calibrate the device. Due to each device's low power dissipation and low temperature drift, no warm-up time is required before reset to accommodate any self-heating effects. However, the voltage reference input should have stabilized to within 0.25% of its final value before $\overline{\text{RST}}$ rises to guarantee an accurate calibration. Later, the CS5101A and CS5102A may be reset at any time to initiate a single full calibration.

When $\overline{\text{RST}}$ is brought low all internal logic clears. When $\overline{\text{RST}}$ returns high on the CS5101A, a calibration cycle begins which takes 11,528,160 master clock cycles to complete (approximately 1.4 seconds with an 8 MHz master clock). The

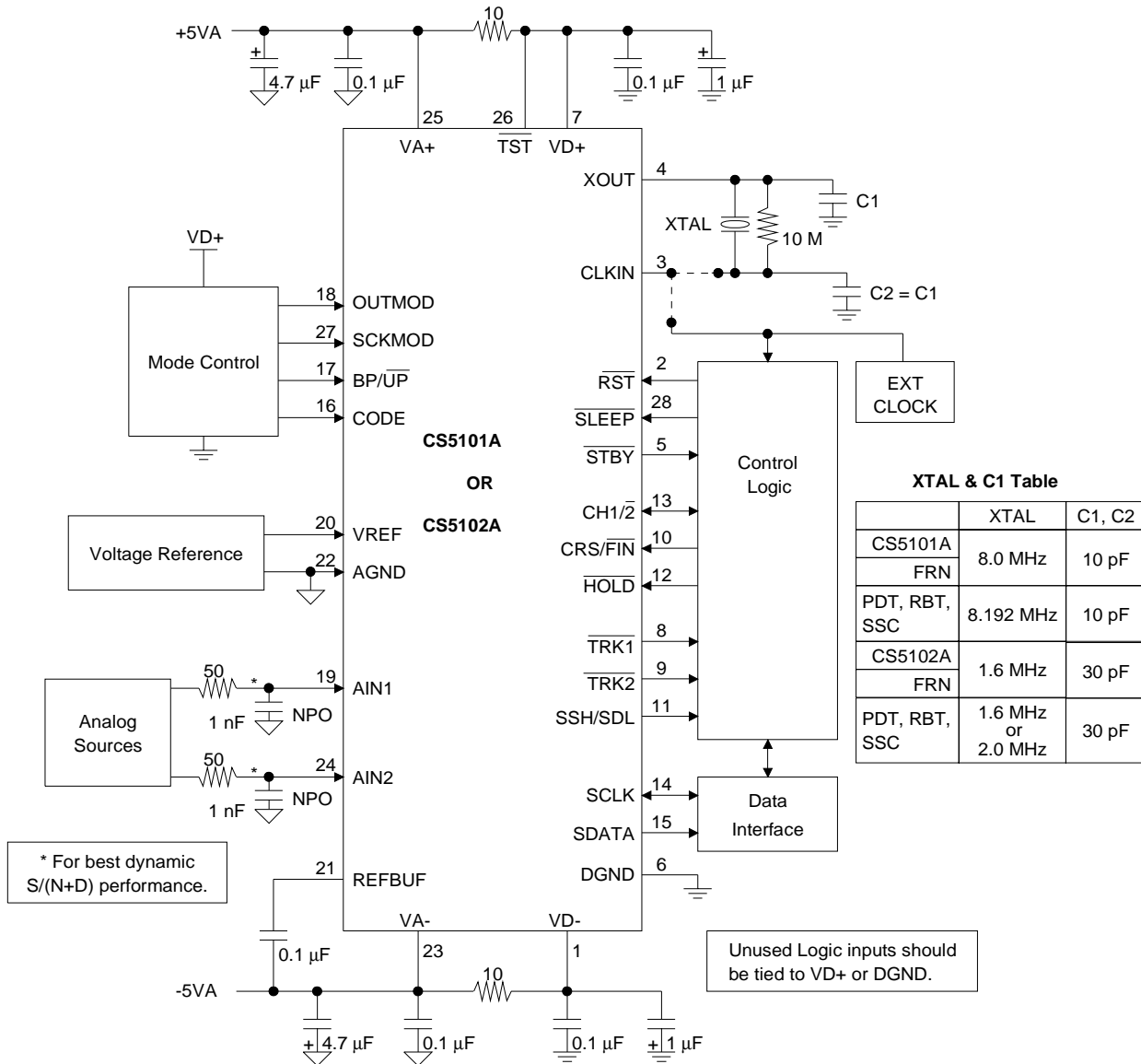

Figure 7. CS5101A/CS5102A System Connection Diagram

calibration cycle on the CS5102A takes 2,882,040 master clock cycles to complete (approximately 1.8 seconds with a 1.6 MHz master clock). The CS5101A's and CS5102A's STBY output remains low throughout the calibration sequence, and a rising transition indicates the device is ready for normal operation. While calibrating, the CS5101A and CS5102A will ignore changes on the HOLD input.

To perform the reset function, a simple power-on reset circuit can be built using a resistor and capacitor as shown in Figure 8. The resistor should

be less than or equal to 10 kΩ. The system power supplies, voltage reference, and clock should all be established prior RST rising.

Single-Channel Operation

The CS5101A and CS5102A can alternatively be used to sample one channel by tying the CH1/2 input high or low. The unused AIN pin should be tied to the analog input signal or to AGND. (If operating in free run mode, AIN1 and AIN2 must

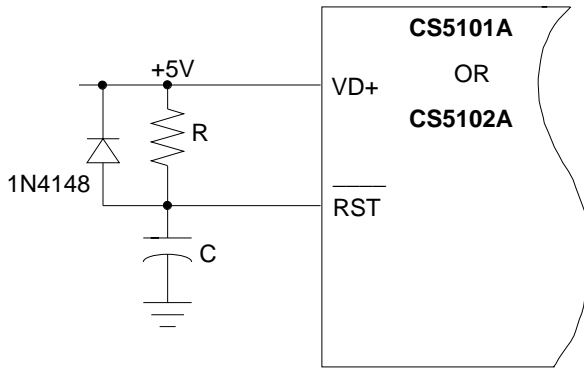

Figure 8. Power-up Reset Circuit

be tied to the same source, as CH1/2 is reconfigured as an output.)

ANALOG CIRCUIT CONNECTIONS

Most popular successive approximation A/D converters generate dynamic loads at their analog connections. The CS5101A and CS5102A internally buffer all analog inputs (AIN1, AIN2, VREF, and AGND) to ease the demands placed on external circuitry. However, accurate system operation still requires careful attention to details at the design stage regarding source impedances as well as grounding and decoupling schemes.

Reference Considerations

An application note titled "Voltage References for the CS501X Series of A/D Converters" is available for the CS5101A and CS5102A. In addition to working through a reference circuit design example, it offers several built-and-tested reference circuits.

During conversion, each capacitor of the calibrated capacitor array is switched between VREF and AGND in a manner determined by the successive-approximation algorithm. The charging and discharging of the array results in a current load at the reference. The CS5101A and CS5102A each include an internal buffer amplifier to minimize the external reference circuit's drive requirement and preserve the reference's in-

tegrity. Whenever the array is switched during conversion, the buffer is used to coarse-charge the array thereby providing the bulk of the necessary charge. The appropriate array capacitors are then switched to the unbuffered VREF pin to avoid any errors due to offsets and/or noise in the buffer.

The external reference circuitry need only provide the residual charge required to fully charge the array after coarse-charging from the buffer. This creates an ac current load as the CS5101A and CS5102A sequence through conversions. The reference circuitry must have a low enough output impedance to drive the requisite current without changing its output voltage significantly. As the analog input signal varies, the switching sequence of the internal capacitor array changes. The current load on the external reference circuitry thus varies in response with the analog input. Therefore, the external reference must not exhibit significant peaking in its output impedance characteristic at signal frequencies or their harmonics.

A large capacitor connected between VREF and AGND can provide sufficiently low output impedance at the high end of the frequency spectrum, while almost all precision references exhibit extremely low output impedance at dc. The presence of large capacitors on the output of some voltage references, however, may cause peaking in the output impedance at intermediate frequencies. Care should be exercised to ensure that significant peaking does not exist or that some form of compensation is provided to eliminate the effect.

The magnitude of the current load on the external reference circuitry will scale to the master clock frequency. At the full-rated 9.216 MHz clock (CS5101A), the reference must supply a maximum load current of 20 μ A peak-to-peak (2 μ A typical). An output impedance of 2 Ω will therefore yield a maximum error of 40 μ V. At the full-rated 2.0 MHz clock (CS5102A), the refer-

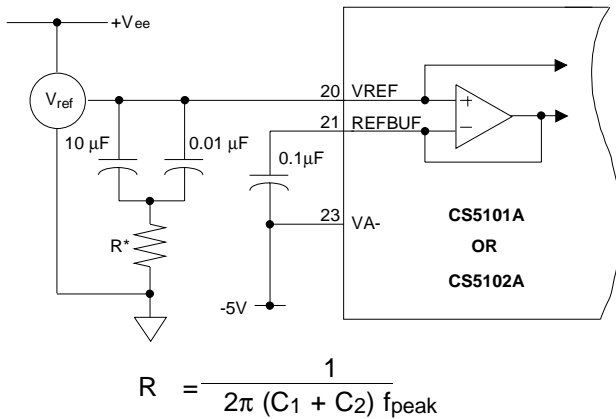

Figure 9. Reference Connections

ence must supply a maximum load current of 5 µA peak-to-peak (0.5 µA typical). An output impedance of 2 Ω will therefore yield a maximum error of 10.0 µV. With a 4.5 V reference and LSB size of 138 µV this would insure approximately 1/14 LSB accuracy. A 10 µF capacitor exhibits an impedance of less than 2 Ω at frequencies greater than 16 kHz. A high-quality tantalum capacitor in parallel with a smaller ceramic capacitor is recommended.

Peaking in the reference’s output impedance can occur because of capacitive loading at its output. Any peaking that might occur can be reduced by placing a small resistor in series with the capacitors. The equation in Figure 9 can be used to help calculate the optimum value of R for a particular reference. The term "f_{peak}" is the frequency of the peak in the output impedance of the reference before the resistor is added.

The CS5101A and CS5102A can operate with a wide range of reference voltages, but signal-to-noise performance is maximized by using as wide a signal range as possible. The recommended reference voltage is 4.5 volts. The CS5101A and CS5102A can actually accept reference voltages up to the positive analog supply. However, the buffer’s offset may increase as the

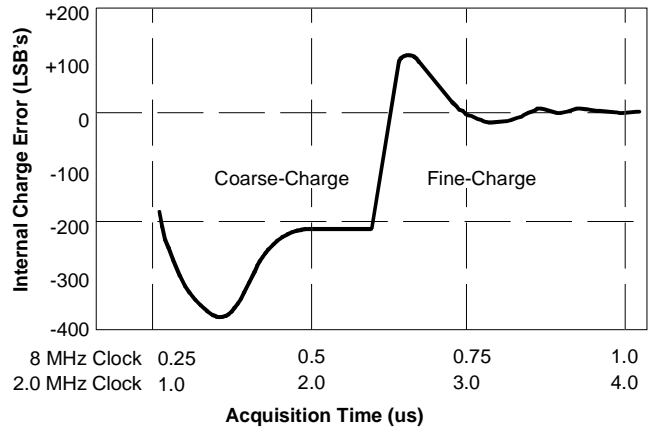

Figure 10. Charge Settling Time (8 and 2.0 MHz Clocks)

reference voltage approaches VA+ thereby increasing external drive requirements at VREF. A 4.5V reference is the maximum reference voltage recommended. This allows 0.5V headroom for the internal reference buffer. Also, the buffer enlists the aid of an external 0.1 µF ceramic capacitor which must be tied between its output, REFBUF, and the negative analog supply, VA-. For more information on references, consult "Application Note: Voltage References for the CS501X Series of A/D Converters".

Analog Input Connection

The analog input terminal functions similarly to the VREF input after each conversion when switching into the track mode. During the first six master clock cycles in the track mode, the buffered version of the analog input is used for coarse-charging the capacitor array. An additional period is required for fine-charging directly from AIN to obtain the specified accuracy. Figure 10 shows this operation. During coarse-charge the charge on the capacitor array first settles to the buffered version of the analog input. This voltage may be offset from the actual input voltage. During fine-charge, the charge then settles to the accurate unbuffered version.

Fine-charge settling is specified as a maximum of 1.125 μs (CS5101A) or 5.625 μs (CS5102A) for an analog source impedance of less than 50 Ω . In addition, the comparator requires a source impedance of less than 400 Ω around 2 MHz for stability. The source impedance can be effectively reduced at high frequencies by adding capacitance from AIN to ground (typically 200 pF). However, high dc source resistances will increase the input's RC time constant and extend the necessary acquisition time. For more information on input amplifiers, consult the application note: *Buffer Amplifiers for the CS501X Series of A/D Converters*.

SLEEP Mode Operation

The CS5101A and CS5102A include a SLEEP pin. When SLEEP is active (low) each device will dissipate very low power to retain its calibration memory when the device is not sampling. It does not require calibration after SLEEP is made inactive (high). When coming out of SLEEP, sampling can begin as soon as the oscillator starts (time will depend on the particular oscillator components) and the REFBUF capacitor is charged (which takes about 3 ms for the CS5101A, 50 ms for the CS5102A). To achieve minimum start-up time, use an external clock and leave the voltage reference powered-up. Connect a resistor (2 k Ω) between pins 20 and 21 to keep the REFBUF capacitor charged. Conversion can then begin as soon as the A/D circuitry has stabilized and performed a track cycle.

To retain calibration memory while SLEEP is active (low) VA+ and VD+ must be maintained at greater than 2.0V. VA- and VD- can be allowed to go to 0 volts. The voltages into VA- and VD- cannot just be "shut-off" as these pins cannot be allowed to float to potentials greater than AGND/DGND. If the supply voltages to VA- and VD- are removed, use a transistor switch to short these to the power supply ground while in SLEEP mode.

Grounding and Power Supply Decoupling

The CS5101A and CS5102A use the analog ground connection, AGND, only as a reference voltage. No dc power currents flow through the AGND connection, and it is completely independent of DGND. However, any noise riding on the AGND input relative to the system's analog ground will induce conversion errors. Therefore, both the analog input and reference voltage should be referred to the AGND pin, which should be used as the entire system's analog ground reference.

The digital and analog supplies are isolated within the CS5101A and CS5102A and are pinned out separately to minimize coupling between the analog and digital sections of the chip. All four supplies should be decoupled to their respective grounds using 0.1 μF ceramic capacitors. If significant low-frequency noise is present on the supplies, tantalum capacitors are recommended in parallel with the 0.1 μF capacitors.

The positive digital power supply of the CS5101A and CS5102A must never exceed the positive analog supply by more than a diode drop or the CS5101A and CS5102A could experience permanent damage. If the two supplies are derived from separate sources, care must be taken that the analog supply comes up first at power-up. The system connection diagram (Figure 7) shows a decoupling scheme which allows the CS5101A and CS5102A to be powered from a single set of $\pm 5\text{V}$ rails. The positive digital supply is derived from the analog supply through a 10 Ω resistor to avoid the analog supply dropping below the digital supply. If this scheme is utilized, care must be taken to insure that any digital load currents (which flow through the 10 Ω resistors) do not cause the magnitude of digital supplies to drop below the analog supplies by more than 0.5 volts. Digital supplies must always remain above the minimum specification.

As with any high-precision A/D converter, the CS5101A and CS5102A require careful attention to grounding and layout arrangements. However, no unique layout issues must be addressed to properly apply the devices. The CDB5101A evaluation board is available for the CS5101A, and the CDB5102A evaluation board is available for the CS5102A. The availability of these boards avoids the need to design, build, and debug a high-precision PC board to initially characterize the part. Each board comes with a socketed CS5101A or CS5102A, and can be reconfigured to simulate any combination of sampling, calibration, master clock, and analog input range conditions.

CS5101A AND CS5102A PERFORMANCE

Differential Nonlinearity

The self-calibration scheme utilized in the CS5101A and CS5102A features a calibration resolution of 1/4 LSB, or 18-bits. This ideally yields DNL of $\pm 1/4$ LSB, with code widths ranging from 3/4 to 5/4 LSB's.

Traditional laser trimmed ADC's have significant differential nonlinearities. Appearing as wide and narrow codes, DNL often causes entire sections of the transfer function to be missing. Although their affect is minor on $S/(N+D)$ with high amplitude signals, DNL errors dominate performance with low-level signals. For instance, a signal 80 dB below full-scale will slew past only 6 or 7 codes. Half of those codes could be missing with a conventional 16-bit ADC which achieves only 14-bit DNL.

The most common source of DNL errors in conventional ADC's is bit weight errors. These can arise due to accuracy limitations in factory trim stations, thermal or physical stresses after calibration, and/or drifts due to aging or temperature variations in the field. Bit-weight errors have a drastic effect on a converter's ac performance.

They can be analyzed as step functions superimposed on the input signal. Since bits (and their errors) switch in and out throughout the transfer curve, their effect is signal dependent. That is, harmonic and intermodulation distortion, as well as noise, can vary with different input conditions.

Differential nonlinearities in successive-approximation ADC's also arise due to dynamic errors in the comparator. Such errors can dominate if the converter's throughput/sampling rate is too high. The comparator will not be allowed sufficient time to settle during each bit decision in the successive-approximation algorithm. The worst-case codes for dynamic errors are the major transitions (1/2 FS; 1/4, 3/4 FS; etc.). Since DNL effects are most critical with low-level signals, the codes around mid-scale (1/2 FS) are most important. Yet those codes are worst-case for dynamic DNL errors!

With all linearity calibration performed on-chip to 18-bits, the CS5101A and CS5102A maintain accurate bit weights. DNL errors are dominated by residual calibration errors of $\pm 1/4$ LSB rather than dynamic errors in the comparator. Furthermore, *all* DNL effects on $S/(N+D)$ are buried by white broadband noise. (See Figures 17 and 19).

Figure 11 illustrates the DNL histogram plot of a typical CS5101A at 25°C. Figure 12 illustrates the DNL of the CS5101A at 138°C ambient after calibration at 25°C ambient. Figures 13 and 14 illustrate the DNL of the CS5102A at 25°C and 138°C ambient, respectively. A histogram test is a statistical method of deriving an A/D converter's differential nonlinearity. A ramp is input to the A/D and a large number of samples are taken to insure a high confidence level in the test's result. The number of occurrences for each code is monitored and stored. A perfect A/D converter would have all codes of equal size and therefore equal numbers of occurrences. In the histogram test a code with the average number of occurrences will be considered ideal (DNL = 0). A

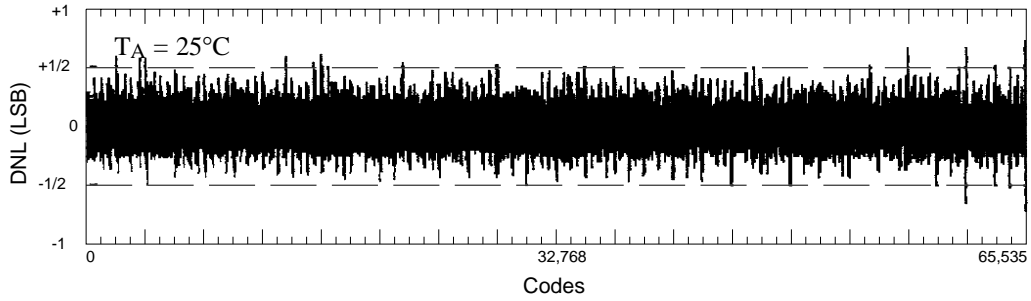

Figure 11. CS5101A DNL Plot; Ambient Temperature at 25°C

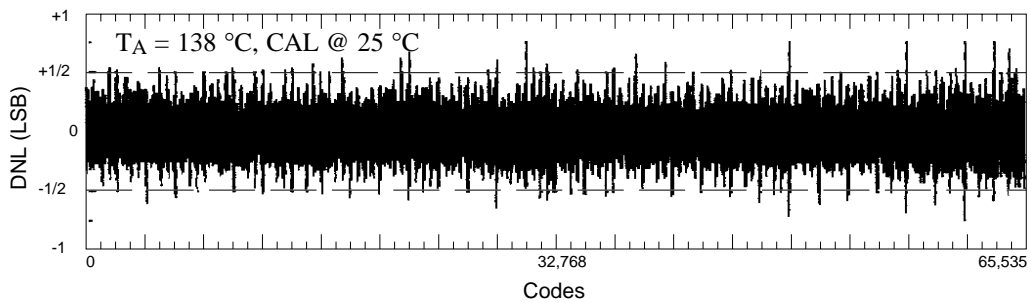

Figure 12. CS5101A DNL Plot; Ambient Temperature at 138°C

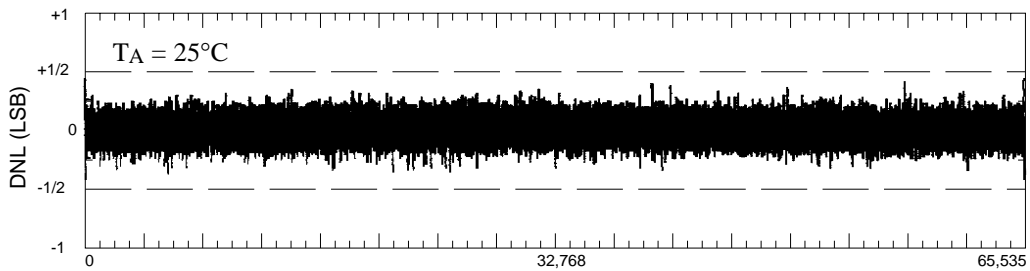

Figure 13. CS5102A DNL Plot; Ambient Temperature at 25°C

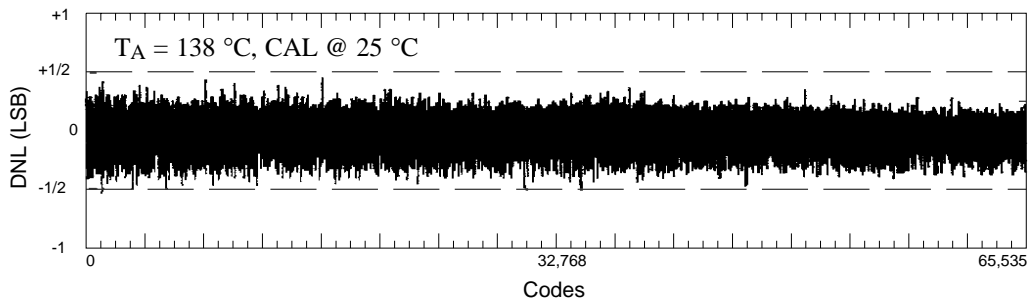

Figure 14. CS5102A DNL Plot; Ambient Temperature at 138°C

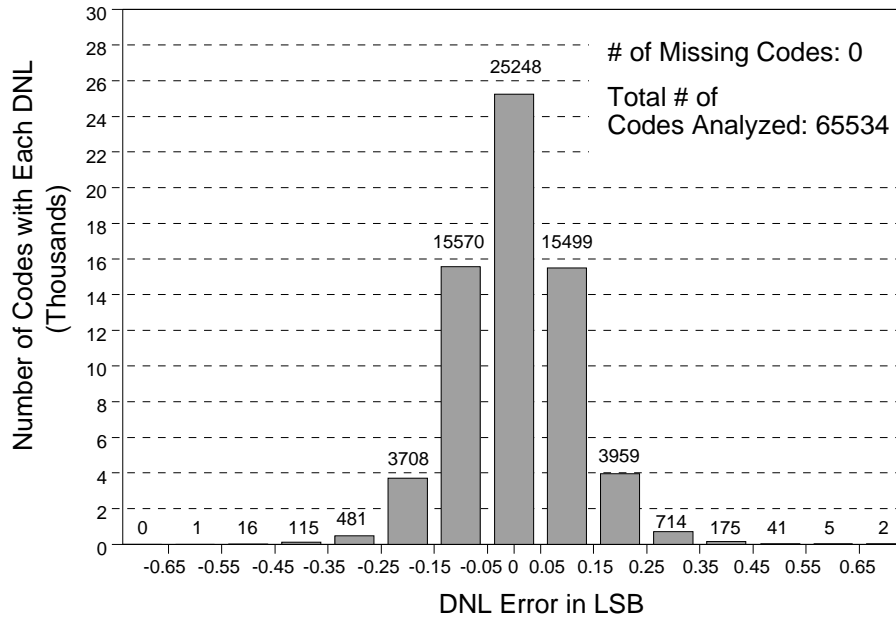

Figure 15. CS5101A DNL Error Distribution

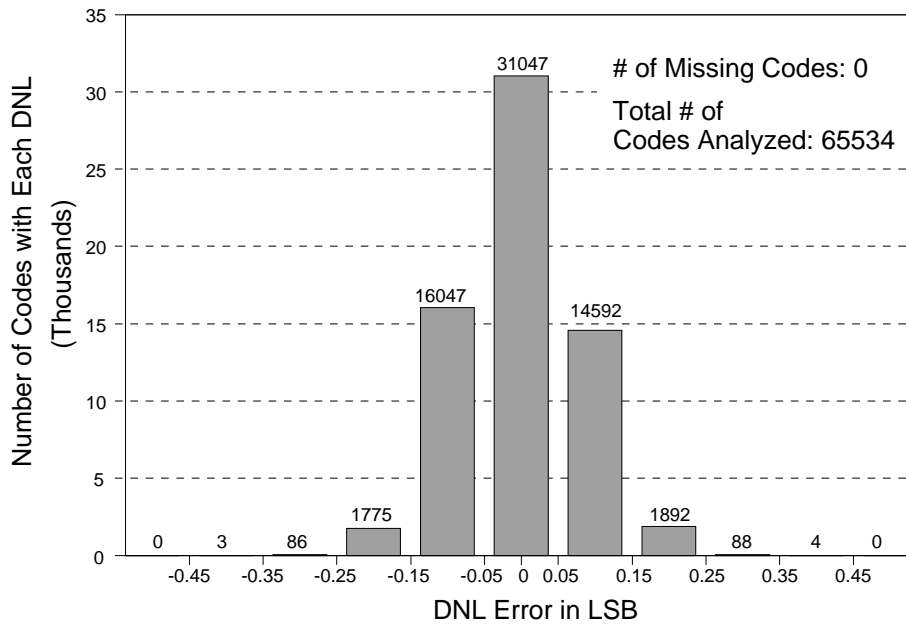

Figure 16. CS5102A DNL Error Distribution

code with more or less occurrences than average will appear as a DNL of greater or less than zero LSB. A missing code has zero occurrences, and will appear as a DNL of -1 LSB.

Figures 15 and 16 illustrate the code width distribution of the DNL plots shown in Figures 11 and 13 respectively. The DNL error distribution plots indicate that the CS5101A and CS5102A calibrate the majority of their codes to tighter

tolerance than the DNL plots in Figures 11 and 13 appear to indicate.

FFT Tests and Windowing

In the factory, the CS5101A and CS5102A are tested using Fast Fourier Transform (FFT) techniques to analyze the converters' dynamic performance. A pure sinewave is applied to the device, and a "time record" of 1024 samples is

captured and processed. The FFT algorithm analyzes the spectral content of the digital waveform and distributes its energy among 512 "frequency bins." Assuming an ideal sinewave, distribution of energy in bins outside of the fundamental and dc can only be due to quantization effects and errors in the CS5101A and CS5102A.

If sampling is not synchronized to the input sine-wave, it is highly unlikely that the time record will contain an integer number of periods of the input signal. However, the FFT assumes that the signal is periodic, and will calculate the spectrum of a signal that appears to have large discontinuities, thereby yielding a severely distorted spectrum. To avoid this problem, the time record is multiplied by a window function prior to performing the FFT. The window function smoothly forces the endpoints of the time record to zero, thereby removing the discontinuities. The effect of the window in the frequency-domain is to convolute the spectrum of the window with that of the actual input.

The quality of the window used for harmonic analysis is typically judged by its highest side-lobe level. A five term window is used in FFT testing of the CS5101A and CS5102A. This windowing algorithm attenuates the side-lobes to below the noise floor. Artifacts of windowing are discarded from the signal-to-noise calculation using the assumption that quantization noise is white. Averaging the FFT results from ten time records filters the spectral variability that can arise from capturing finite time records without disturbing the total energy outside the fundamental. All harmonics are visible in the plots. For more information on FFT's and windowing refer to: F.J. HARRIS, "On the use of windows for harmonic analysis with the Discrete Fourier Transform", Proc. IEEE, Vol. 66, No. 1, Jan 1978, pp.51-83. This is available on request from Crystal Semiconductor.

As illustrated in Figure 17, the CS5101A typically provides about 92 dB S/(N+D) and

0.001% THD at 25°C. Figure 18 illustrates only minor degradation in performance when the ambient temperature is raised to 138°C. Figure 19 and 20 illustrate that the CS5102A typically yields >92 dB S/(N+D) and 0.001% THD even with a large change in ambient temperature. Unlike conventional successive-approximation ADC's, the signal-to-noise and dynamic range of the CS5101A and CS5102A are not limited by differential nonlinearities (DNL) caused by calibration errors. Rather, the dominant noise source is broadband thermal noise which aliases into the baseband. This *white* broadband noise also appears as an idle channel noise of 1/2 LSB (rms).

Sampling Distortion

Like most discrete sample/hold amplifier designs, the inherent sample/hold of the CS5101A and CS5102A exhibits a frequency-dependent distortion due to nonideal sampling of the analog input voltage. The calibrated capacitor array used during conversions is also used to track and hold the analog input signal. The conversion is not performed on the analog input voltage per se, but is actually performed on the charge trapped on the capacitor array at the moment the HOLD command is given. The charge on the array ideally assumes a linear relationship to the analog input voltage. Any deviation from this linear relationship will result in conversion errors even if the conversion process proceeds flawlessly.

At dc, the DAC capacitor array's voltage coefficient dictates the converter's linearity. This variation in capacitance with respect to applied signal voltage yields a nonlinear relationship between the charge on the array and the analog input voltage and places a bow or wave in the transfer function. This is the dominant source of distortion at low input frequencies (Figures 17,18,19, and 20).

The ideal relationship between the charge on the array and the input voltage can also be distorted

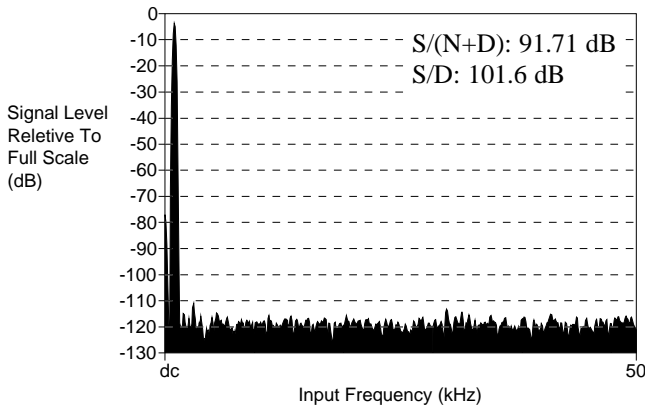

Figure 17. CS5101A FFT (SSC Mode, 1-Channel)

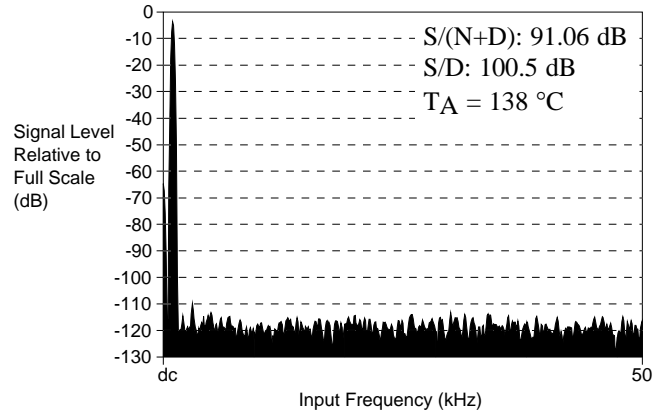

Figure 18. CS5101A FFT (SSC Mode, 1-Channel)

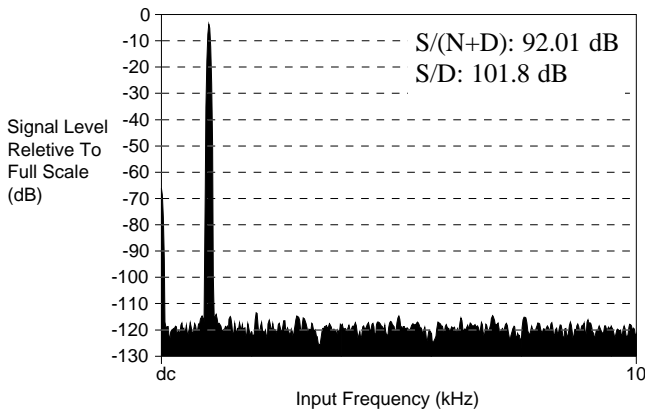

Figure 19. CS5102A FFT (SSC Mode, 1-Channel)

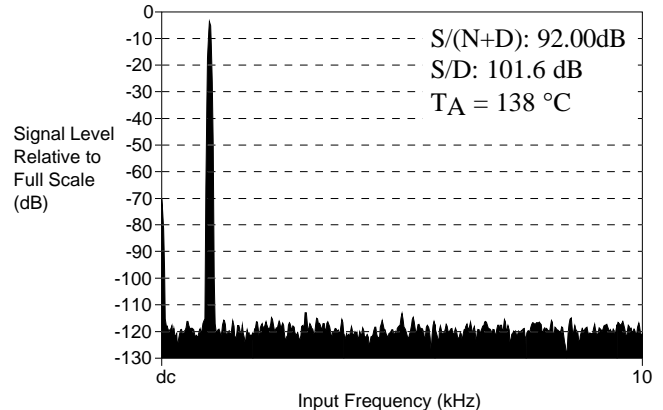

Figure 20. CS5102A FFT (SSC Mode, 1-Channel)

at high signal frequencies due to nonlinearities in the internal MOS switches. Dynamic signals cause ac current to flow through the switches connecting the capacitor array to the analog input pin in the track mode. Nonlinear on-resistance in the switches causes a nonlinear voltage drop. This effect worsens with increased signal frequency and slew rate. This distortion is negligible at signal levels below -10 dB of full-scale.

Noise

An A/D converter’s noise can be described like that of any other analog component. However, the converter’s output is in digital form so any filtering of its noise must be performed in the digital domain. Digitized samples of analog in-

puts are often considered individual, static snapshots in time with no uncertainty or noise. In reality, the result of each conversion depends on the analog input level and the instantaneous value of noise sources in the ADC. If sequential samples from the ADC are treated as a "waveform", simple filtering can be implemented in software to improve noise performance with minimal processing overhead.

All analog circuitry in the CS5101A and CS5102A is wideband in order to achieve fast conversions and high throughput. Wideband noise in the CS5101A and CS5102A integrates to 35 μ V rms in unipolar mode (70 μ V rms in bipolar mode). This is approximately 1/2 LSB rms with a 4.5V reference in both modes. Figure 21

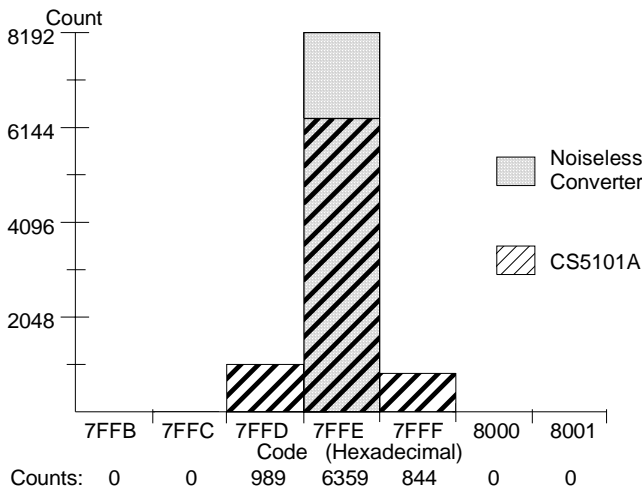

Figure 21. 5101A Histogram Plot of 8192 Conversion Inputs

shows a histogram plot of output code occurrences obtained from 8192 samples taken from a CS5101A in the bipolar mode. Hexadecimal code 7FFE was arbitrarily selected and the analog input was set close to code center. With a noiseless converter, code 7FFE would always appear. The histogram plot of the device has a "bell" shape with all codes other than 7FFE due to internal noise. Figure 22 illustrates the noise histogram of the CS5102A.

In a sampled data system all information about the analog input applied to the sample/hold appears in the baseband from dc to one-half the sampling rate. This includes high-frequency components which alias into the baseband. Low-pass (anti-alias) filters are therefore used to remove frequency components in the input signal which are above one-half the sample rate. However, all wideband noise introduced by the CS5101A and CS5102A still aliases into the baseband. This "white" noise is evenly spread from dc to one-half the sampling rate and integrates to 35 μ V rms in unipolar mode.

Noise in the digital domain can be reduced by sampling at higher than the desired word rate and

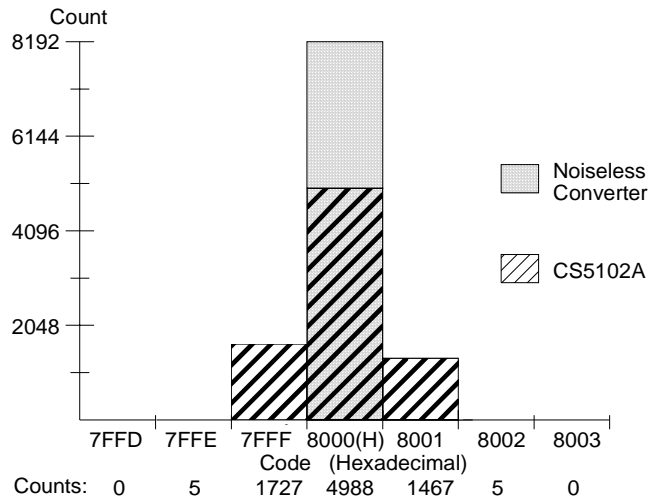

Figure 22. 5102A Histogram Plot of 8192 Conversion Inputs

averaging multiple samples for each word. Oversampling spreads the device's noise over a wider band (for lower noise density), and averaging applies a low-pass response which filters noise above the desired signal bandwidth. In general, the device's noise performance can be maximized in any application by always sampling at the maximum specified rate of 100 kHz (CS5101A) or 20 kHz (CS5102A) (for lowest noise density) and digitally filtering to the desired signal bandwidth.

Aperture Jitter

Track-and-hold amplifiers commonly exhibit two types of aperture jitter. The first, more appropriately termed "aperture window", is an input voltage dependent variation in the aperture delay. Its signal-dependency causes distortion at high frequencies. The proprietary architecture of the CS5101A and CS5102A avoids applying the input voltage across a sampling switch, thus avoiding any "aperture window" effects. The second type of aperture jitter, due to component noise, assumes a random nature. With only 100 ps peak-to-peak aperture jitter, the CS5101A and CS5102A can process full-scale signals up to

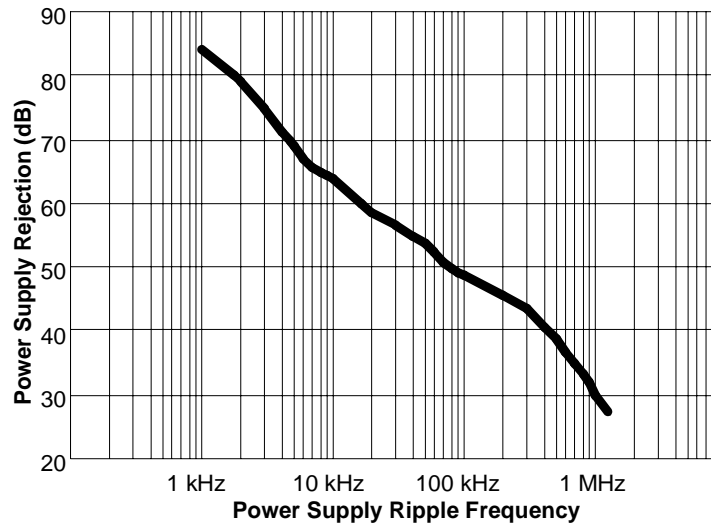

Figure 23. Power Supply Rejection

1/2 the throughput frequency without significant errors due to aperture jitter.

Power Supply Rejection

The power supply rejection performance of the CS5101A and CS5102A is enhanced by the on-chip self-calibration and an "auto-zero" process. Drifts in power supply voltages at frequencies less than the calibration rate have negligible effect on the device's accuracy. This is because the CS5101A and CS5102A adjust their offset to within a small fraction of an LSB during calibration. Above the calibration frequency the excellent power supply rejection of the internal amplifiers is augmented by an auto-zero process. Any offsets are stored on the capacitor array and are effectively subtracted once conversion is initiated. Figure 23 shows power supply rejection of the CS5101A and CS5102A in the bipolar mode with the analog input grounded and a 300 mV p-p ripple applied to each supply. Power supply rejection improves by 6 dB in the unipolar mode.

CS5101A/CS5102A Improvements Over Earlier CS5101/CS5102

The CS5101A/CS5102A are improved versions of the earlier CS5101/CS5102 devices. Primary improvements are:

- 1) Improved DNL at high temperature (>70 °C)
- 2) Improved input slew rate, yielding improved full scale settling between conversions.
- 3) Modifying the previous SSH pin to SSH/SDL (Simultaneous Sample Hold/Serial Data Latch). The SSH/SDL new function provides a logic signal which frames the 16 data bits in SSC and FRN serial modes. This signal is ideal for easy interface to serial to parallel shift registers (74HC595) and to DSP serial ports.

Table 3 summarizes all the improvements.

Function	CS5101A/CS5102A	CS5101/CS5102																		
Better DNL	No missing codes at +125 °C	Some missed codes at +125 °C																		
Faster Fine Charge Slew Rate (V/μs)	<table border="1"> <thead> <tr> <th></th> <th>CS5101A</th> <th>CS5102A</th> </tr> </thead> <tbody> <tr> <td>Unipolar/Fine</td> <td>2</td> <td>0.4</td> </tr> <tr> <td>Bipolar/Fine</td> <td>4</td> <td>0.8</td> </tr> </tbody> </table>		CS5101A	CS5102A	Unipolar/Fine	2	0.4	Bipolar/Fine	4	0.8	<table border="1"> <thead> <tr> <th></th> <th>CS5101</th> <th>CS5102</th> </tr> </thead> <tbody> <tr> <td>Unipolar/Fine</td> <td>1.3</td> <td>0.1</td> </tr> <tr> <td>Bipolar/Fine</td> <td>2.6</td> <td>0.2</td> </tr> </tbody> </table>		CS5101	CS5102	Unipolar/Fine	1.3	0.1	Bipolar/Fine	2.6	0.2
	CS5101A	CS5102A																		
Unipolar/Fine	2	0.4																		
Bipolar/Fine	4	0.8																		
	CS5101	CS5102																		
Unipolar/Fine	1.3	0.1																		
Bipolar/Fine	2.6	0.2																		
Improved Serial Interface	Has serial data latch signal (SSH/SDL).	Does not have serial data latch (SDL) signal.																		
CLKIN Rate	CS5101A maximum CLKIN is 9.216 MHz CS5102A maximum CLKIN is 2.0 MHz	CS5101 maximum CLKIN is 8.0 MHz CS5102 maximum CLKIN is 1.6 MHz																		
Code and BP/UP Pin Function	Independent setting of 2's complement or offset binary coding (CODE) and bipolar or unipolar input range (BP/UP)	Selecting unipolar input range forces offset binary operation, independent of the CODE pin state																		
CRS/FIN Pin	Can be high or low during calibration	CRS/FIN must be held low during calibration																		

Table 3. CS5101A/CS5102A Improvements over CS5101/CS5102

Schematic & Layout Review Service

Confirm Optimum Schematic & Layout Before Building Your Board.

For Our Free Review Service Call Applications Engineering.

Call: (5 1 2) 4 4 5 - 7 2 2 2



PIN DESCRIPTIONS

NEGATIVE DIGITAL POWER	VD-	1	28	SLEEP	SLEEP (LOW POWER) MODE
RESET & INITIATE CALIBRATION	RST	2	27	SCKMOD	SERIAL CLOCK MODE SELECT
MASTER CLOCK INPUT	CLKIN	3	26	TEST	TEST
CRYSTAL OUTPUT	XOUT	4	25	VA+	POSITIVE ANALOG POWER
STANDBY (CALIBRATING)	STBY	5	24	AIN2	CHANNEL 2 ANALOG INPUT
DIGITAL GROUND	DGND	6	23	VA-	NEGATIVE ANALOG POWER
POSITIVE DIGITAL POWER	VD+	7	22	AGND	ANALOG GROUND
TRACKING CHANNEL 1	TRK1	8	21	REFBUF	REFERENCE BUFFER
TRACKING CHANNEL 2	TRK2	9	20	VREF	VOLTAGE REFERENCE
COARSE/FINE CHARGE CONTROL	CRS/FIN	10	19	AIN1	CHANNEL 1 ANALOG INPUT
SIMULTANEOUS SH/SERIAL DATA LATCH	SSH/SDL	11	18	OUTMOD	OUTPUT MODE SELECT
HOLD & CONVERT	HOLD	12	17	BP/UP	BIPOLAR/UNIPOLAR SELECT
INPUT CHANNEL SELECT	CH1/2	13	16	CODE	BINARY/2's COMPLEMENT SELECT
SERIAL DATA CLOCK	SCLK	14	15	SDATA	SERIAL DATA OUTPUT

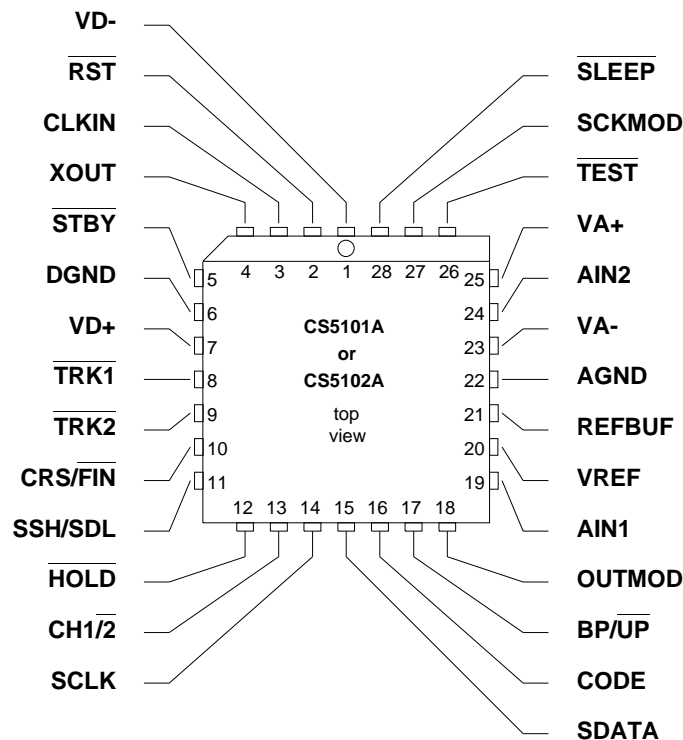

Power Supply Connections

VD+ - Positive Digital Power, PIN 7.

Positive digital power supply. Nominally +5 volts.

VD- - Negative Digital Power, PIN 1.

Negative digital power supply. Nominally -5 volts.

DGND - Digital Ground, PIN 6.

Digital ground [reference].

VA+ - Positive Analog Power, PIN 25.

Positive analog power supply. Nominally +5 volts.

VA- - Negative Analog Power, PIN 23.

Negative analog power supply. Nominally -5 volts.

AGND - Analog Ground, PIN 22.

Analog ground reference.

Oscillator

CLKIN - Clock Input, PIN 3.

All conversions and calibrations are timed from a master clock which can be externally supplied by driving CLKIN [this input TTL-compatible, CMOS recommended].

XOUT - Crystal Output, PIN 4.

The master clock can be generated by tying a crystal across the CLKIN and XOUT pins. If an external clock is used, XOUT must be left floating.

Digital Inputs

 $\overline{\text{HOLD}}$ - Hold, PIN 12.

A falling transition on this pin sets the CS5101A or CS5102A to the hold state and initiates a conversion. This input must remain low for at least $1/\text{clk} + 20$ ns. When operating in Free Run Mode, $\overline{\text{HOLD}}$ is disabled, and should be tied to DGND or VD+.

 $\overline{\text{CRS/FIN}}$ - Coarse Charge/Fine Charge Control, PIN 10.

When brought high during acquisition time, $\overline{\text{CRS/FIN}}$ forces the CS5101A or CS5102A into coarse charge state. This engages the internal buffer amplifier to track the analog input and charges the capacitor array much faster, thereby allowing the CS5101A or CS5102A to track high slewing signals. In order to get an accurate sample, the last coarse charge period before initiating a conversion (bringing $\overline{\text{HOLD}}$ low) must be longer than $0.75 \mu\text{s}$ (CS5101A) or $3.75 \mu\text{s}$ (CS5102A). Similarly, the fine charge period immediately prior to conversion must be at least $1.125 \mu\text{s}$ (CS5101A) or $5.625 \mu\text{s}$ (CS5102A). The $\overline{\text{CRS/FIN}}$ pin must be low during conversion time. For normal operation, $\overline{\text{CRS/FIN}}$ should be tied low, in which case the CS5101A or CS5102A will automatically enter coarse charge for 6 clock cycles immediately after the end of conversion.

CH1/2[̄] - Left/Right Input Channel Select, PIN 13.

Status at the end of a conversion cycle determines which analog input channel will be acquired for the next conversion cycle. When in Free Run Mode, CH1/2 is an output, and will indicate which channel is being sampled during the current acquisition phase.

SLEEP - Sleep, PIN 28.

When brought low causes the CS5101A or CS5102A to enter a power-down state. All calibration coefficients are retained in memory, so no recalibration is needed after returning to the normal operating mode. If using the internal crystal oscillator, time must be allowed after SLEEP returns high for the crystal oscillator to stabilize. SLEEP should be tied high for normal operation.

CODE - 2's Complement/Binary Coding Select, PIN 16.

Determines whether output data appears in 2's complement or binary format. If high, 2's complement; if low, binary.

BP/UP[̄] - Bipolar/Unipolar Input Range Select, PIN 17.

When low, the CS5101A or CS5102A accepts a unipolar input range from AGND to VREF. When high, the CS5101A or CS5102A accepts bipolar inputs from -VREF to +VREF.

SCKMOD - Serial Clock Mode Select, PIN 27.

When high, the SCLK pin is an input; when low, it is an output. Used in conjunction with OUTMOD to select one of 4 output modes described in Table 2.

OUTMOD - Output Mode Select, PIN 18.

The status of SCKMOD and OUTMOD determine which of four output modes is utilized. The four modes are described in Table 2.

SCLK - Serial Clock, PIN 14.

Serial data changes status on a falling edge of this input, and is valid on a rising edge. When SCKMOD is high SCLK acts as an input. When SCKMOD is low the CS5101A or CS5102A generates its own serial clock at one-fourth the master clock frequency and SCLK is an output.

RST[̄] - Reset, PIN 2.

When taken low, all internal digital logic is reset. Upon returning high, a full calibration sequence is initiated which takes 11,528,160 CLKIN cycles (CS5101A) or 2,882,040 CLKIN cycles (CS5102A) to complete. During calibration, the HOLD input will be ignored. The CS5101A or CS5102A must be reset at power-up for calibration, however; calibration is maintained during SLEEP mode, and need not be repeated when resuming normal operation.

Analog Inputs**AIN1, AIN2 - Channel 1 and 2 Analog Inputs, PINS 19 and 24.**

Analog input connections for the left and right input channels.

VREF - Voltage Reference, PIN 20.

The analog reference voltage which sets the analog input range. In unipolar mode VREF sets full-scale; in bipolar mode its magnitude sets both positive and negative full-scale.

Digital Outputs

$\overline{\text{STBY}}$ - Standby (Calibrating), PIN 5.

Indicates calibration status after reset. Remains low throughout the calibration sequence and returns high upon completion.

SDATA - Serial Output, PIN 15.

Presents each output data bit on a falling edge of SCLK. Data is valid to be latched on the rising edge of SCLK.

SSH/SDL - Simultaneous Sample/Hold / Serial Data Latch, PIN 11.

Used to control an external sample/hold amplifier to achieve simultaneous sampling between channels. In FRN and SSC modes (SCLK is an output), this signal provides a convenient latch signal which forms the 16 data bits. This can be used to control external serial to parallel latches, or to control the serial port in a DSP.

$\overline{\text{TRK1}}$, $\overline{\text{TRK2}}$ - Tracking Channel 1, Tracking Channel 2, PINS 8 and 9.

Falls low at the end of a conversion cycle, indicating the acquisition phase for the corresponding channel. The $\overline{\text{TRK1}}$ or $\overline{\text{TRK2}}$ pin will return high at the beginning of conversion for that channel.

Analog Outputs

REFBUF - Reference Buffer Output, PIN 21.

Reference buffer output. A 0.1 μF ceramic capacitor must be tied between this pin and VA-.

Miscellaneous

$\overline{\text{TEST}}$ - Test, PIN 26.

Allows access to the CS5101A's and the CS5102A's test functions which are reserved for factory use. Must be tied to VD+.

PARAMETER DEFINITIONS**Linearity Error**

The deviation of a code from a straight line passing through the endpoints of the transfer function after zero- and full-scale errors have been accounted for. "Zero-scale" is a point 1/2 LSB below the first code transition and "full-scale" is a point 1/2 LSB beyond the code transition to all ones. The deviation is measured from the middle of each particular code. Units in % Full-Scale.

Differential Linearity

Minimum resolution for which no missing codes is guaranteed. Units in bits.

Full Scale Error

The deviation of the last code transition from the ideal ($V_{REF}-3/2$ LSB's). Units in LSB's.

Unipolar Offset

The deviation of the first code transition from the ideal (1/2 LSB above AGND) when in unipolar mode (BP/UP low). Units in LSB's.

Bipolar Offset

The deviation of the mid-scale transition (011...111 to 100...000) from the ideal (1/2 LSB below AGND) when in bipolar mode (BP/UP high). Units in LSB's.

Bipolar Negative Full-Scale Error

The deviation of the first code transition from the ideal when in bipolar mode (BP/UP high). The ideal is defined as lying on a straight line which passes through the final and mid-scale code transitions. Units in LSB's.

Signal to Peak Harmonic or Noise

The ratio of the rms value of the signal to the rms value of the next largest spectral component below the Nyquist rate (excepting dc). This component is often an aliased harmonic when the signal frequency is a significant proportion of the sampling rate. Expressed in decibels.

Total Harmonic Distortion

The ratio of the rms sum of all harmonics to the rms value of the signal. Units in percent.

Signal-to-(Noise + Distortion)

The ratio of the rms value of the signal to the rms sum of all other spectral components below the Nyquist rate (excepting dc), including distortion components. Expressed in decibels.

Aperture Time

The time required after the hold command for the sampling switch to open fully. Effectively a sampling delay which can be nulled by advancing the sampling signal. Units in nanoseconds.

Aperture Jitter

The range of variation in the aperture time. Effectively the "sampling window" which ultimately dictates the maximum input signal slew rate acceptable for a given accuracy. Units in picoseconds.

CS5101A Ordering Guide

Model	Conversion Time	Throughput	Linearity	Temperature	Package
CS5101A-JP8	8.13 μ s	100 kHz	0.003%	0 to 70 °C	28-Pin Plastic DIP
CS5101A-KP8	8.13 μ s	100 kHz	0.002%	0 to 70 °C	28-Pin Plastic DIP
CS5101A-JP16	16.25 μ s	50 kHz	0.003%	0 to 70 °C	28-Pin Plastic DIP
CS5101A-JL8	8.13 μ s	100 kHz	0.003%	0 to 70 °C	28-Pin PLCC
CS5101A-KL8	8.13 μ s	100 kHz	0.002%	0 to 70 °C	28-Pin PLCC
CS5101A-JL16	16.25 μ s	50 kHz	0.003%	0 to 70 °C	28-Pin PLCC
CS5101A-AP8	8.13 μ s	100 kHz	0.003%	-40 to 85 °C	28-Pin Plastic DIP
CS5101A-BP8	8.13 μ s	100 kHz	0.002%	-40 to 85 °C	28-Pin Plastic DIP
CS5101A-AL8	8.13 μ s	100 kHz	0.003%	-40 to 85 °C	28-Pin PLCC
CS5101A-BL8	8.13 μ s	100 kHz	0.002%	-40 to 85 °C	28-Pin PLCC

CS5102A Ordering Guide

Model	Conversion Time	Throughput	Linearity	Temperature	Package
CS5102A-JP	40 μ s	20 kHz	0.003%	0 to 70 °C	28-Pin Plastic DIP
CS5102A-KP	40 μ s	20 kHz	0.0015%	0 to 70 °C	28-Pin Plastic DIP
CS5102A-JL	40 μ s	20 kHz	0.003%	0 to 70 °C	28-Pin PLCC
CS5102A-KL	40 μ s	20 kHz	0.0015%	0 to 70 °C	28-Pin PLCC
CS5102A-AP	40 μ s	20 kHz	0.003%	-40 to 85 °C	28-Pin Plastic DIP
CS5102A-BP	40 μ s	20 kHz	0.0015%	-40 to 85 °C	28-Pin Plastic DIP
CS5102A-AL	40 μ s	20 kHz	0.003%	-40 to 85 °C	28-Pin PLCC
CS5102A-BL	40 μ s	20 kHz	0.0015%	-40 to 85 °C	28-Pin PLCC
CS5102A-BL14Z	40 μ s	20 kHz	0.0015%	-40 to 85 °C	28-Pin PLCC Lead Free

28 PIN PLASTIC (PDIP) (600 MIL) PACKAGE DRAWING

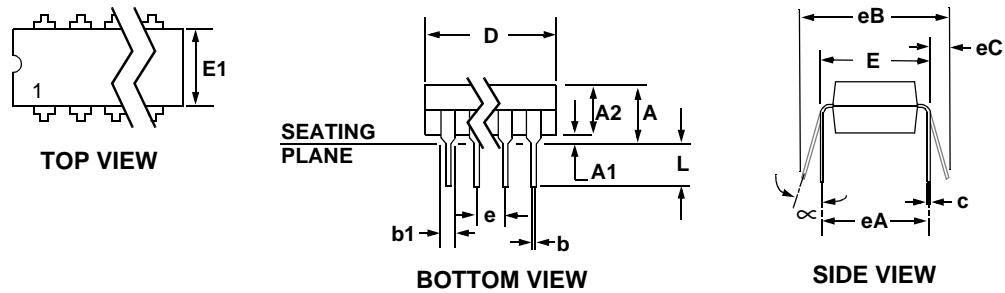

DIM	INCHES			MILLIMETERS		
	MIN	NOM	MAX	MIN	NOM	MAX
A	0.000	--	0.200	0.00	--	5.08
A1	0.020	0.022	0.025	0.508	0.560	0.64
A2	0.120	0.150	0.180	3.05	3.81	4.57
b	0.015	0.018	0.022	0.38	0.46	0.56
b1	0.030	0.050	0.070	0.76	1.27	1.78
c	0.008	0.010	0.014	0.20	0.25	0.36
D	1.380	1.473	1.565	35.05	37.40	39.75
E	0.600	0.615	0.630	15.24	15.62	15.88
E1	0.500	0.540	0.570	12.70	13.71	14.47
e	--	0.070 BSC	--	--	1.78 BSC	--
eA	--	0.600 BSC	--	--	15.24 BSC	--
eB	0.600	0.650	0.700	15.24	16.89	17.78
eC	0.000	0.030	0.060	0.00	0.762	1.52
L	0.100	0.130	0.140	2.54	3.302	5.08
∞	0°	8°	15°	0°	8°	15°

JEDEC # : MS-020

Controlling Dimension is Inches

28L PLCC PACKAGE DRAWING

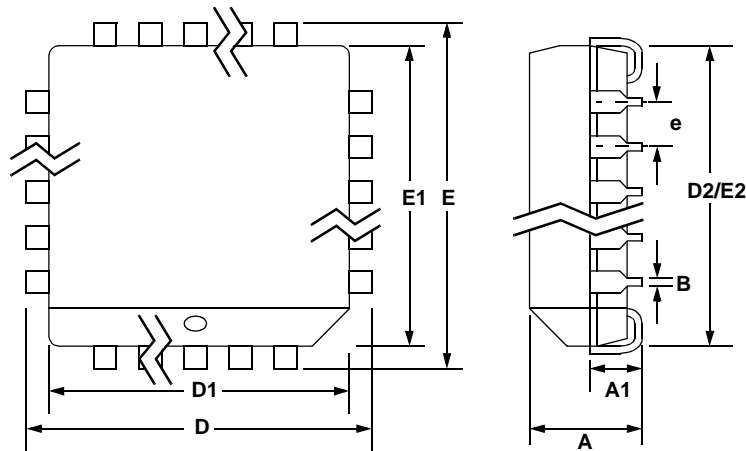

DIM	INCHES			MILLIMETERS		
	MIN	NOM	MAX	MIN	NOM	MAX
A	0.165	0.1725	0.180	4.191	4.3815	4.572
A1	0.090	0.105	0.120	2.286	2.667	3.048
B	0.013	0.017	0.021	0.3302	0.4318	0.533
D	0.485	0.490	0.495	12.319	12.446	12.573
D1	0.450	0.453	0.456	11.430	11.506	11.582
D2	0.390	0.410	0.430	9.906	10.414	10.922
E	0.485	0.490	0.495	12.319	12.446	12.573
E1	0.450	0.453	0.456	11.430	11.506	11.582
E2	0.390	0.410	0.430	9.906	10.414	10.922
e	0.040	0.050	0.060	1.016	1.270	1.524

JEDEC # : MS-047 AA-AF

Controlling Dimension is Inches

28 PIN LCC PACKAGE DRAWING

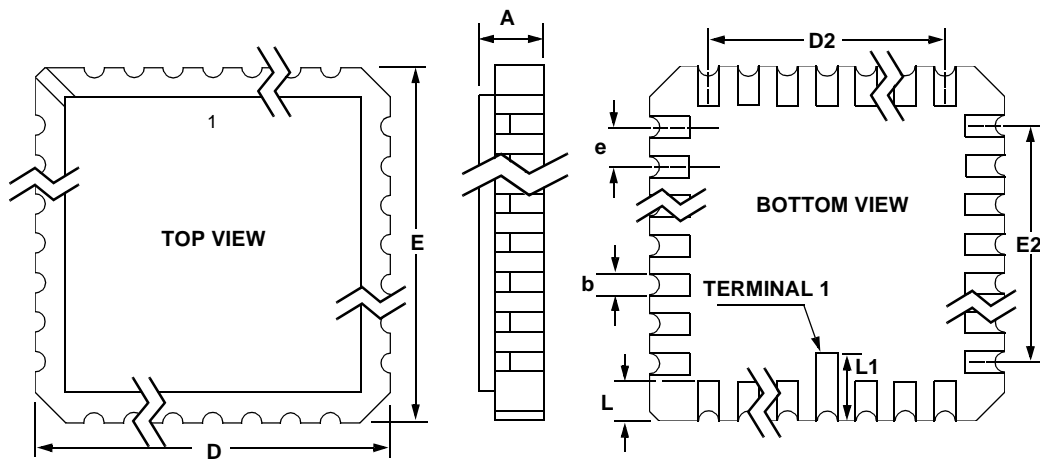

DIM	INCHES			MILLIMETERS		
	MIN	NOM	MAX	MIN	NOM	MAX
A	0.062	0.080	0.098	1.57	2.025	2.48
b	0.020	0.025	0.030	0.51	0.635	0.76
D/E	0.443	0.4525	0.462	11.25	11.515	11.73
D2/E2	0.295	0.300	0.305	7.49	7.620	7.75
e	0.045	0.050	0.055	1.14	1.270	1.40
L	0.045	0.050	0.055	1.14	1.270	1.40
L1	0.075	0.085	0.095	1.91	2.160	2.41

Controlling Dimension is Inches