

## Echo-Cancelling Codec

### Features

- Applicable in:
  - Digital-Cellular Hands-Free Phones
  - Analog-Cellular Hands-Free Phones
  - Office Speaker Phones
  - Desktop & Video Teleconferencing
- Echo Cancellation
  - Up to 60 dB ERLE
  - 512 Tap (64 ms at 8 kHz sampling rate)
  - Split Mode For Two Echo Cancellers
- Serial Data/Control Interface
- On-Chip Delta-Sigma Codec
  - < 1% THD, 8 Ω Load On Output
  - > 70 dB S/(N+D) on Input
  - 300-3600 Hz Bandwidth (8 kHz sampling rate)
  - Volume Control
  - Microphone Preamp
- Automatic Gain Control (AGC)
- No Training Signals Generated

### Description

The CS6403 is an application-specific digital signal processor optimized for network and acoustic echo cancellation applications. A high-quality codec is integrated with the processor to provide a complete, low-cost echo-cancellation solution.

The CS6403 is a fully independent processor that requires no signal processing support to implement its cancellation functions. Volume control, AGC, and sleep functions are also provided.

The on-chip ADC and DAC employ over-sampling technology, which eliminates the need for complex external anti-aliasing and reconstruction filters, further reducing system cost.

The CS6403 has a serial interface that is compatible with most DSPs and PCM codecs. Clock and sync lines control the transfer of serial data via the separate serial data-in and data-out pins. Both 16-bit audio data and control/status information may be multiplexed on this serial channel using a steering bit.

### ORDERING INFORMATION

CS6403-IQ	-40° to +85° C	44-pin TQFP
CS6403-IL	-40° to +85° C	44-pin PLCC
CDB6403		Evaluation Board

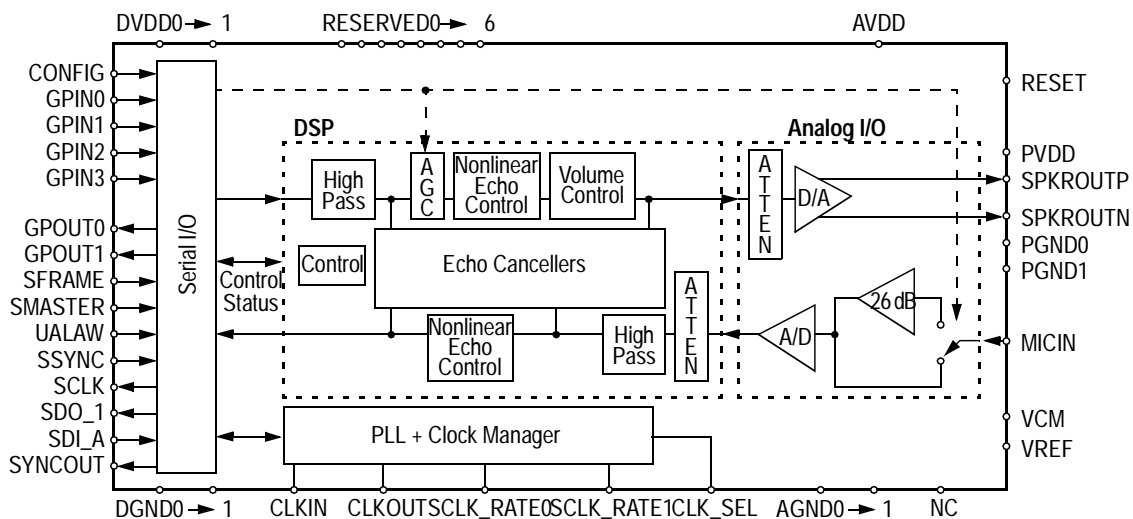

### Preliminary Product Information

This document contains information for a new product. Cirrus Logic reserves the right to modify this product without notice.

**ADC CHARACTERISTICS** ( $T_A = 25\text{ }^\circ\text{C}$ ; All DVDD, AVDD, and PVDD = 5.0V, Digital Input Levels: Logic 0 = 0V, Logic 1 = DVDD; Signal test frequency 1kHz, word rate ( $F_s$ ) = 8kHz, audio signal measurement bandwidth is 20Hz to 4kHz; Microphone amp gain = 0dB; SPRKOUT outputs connected to 8 $\Omega$  load; CLKIN frequency = 8.192MHz; unless otherwise specified) Note 1.

Parameter	Symbol	Min	Typ	Max	Units
ADC Resolution With No Missing Codes		12	-	-	bits
Instantaneous Dynamic Range	IDR	67	72	-	dB
Total Harmonic Distortion at -0.5dBFS signal level	THD	-	0.01	0.05	%
Gain Drift (Note 2)		-	150	-	ppm/ $^\circ\text{C}$
Offset Error		-	0	2	LSB
Full Scale Input Voltage (Note 3)		0.85	1.0	1.1	$V_p$
Input Resistance (at MICIN) (Note 2)		25	-	-	$k\Omega$
Input Capacitance (at MICIN) (Note 2)		-	15	-	pF
Sample Rate	$F_s$	-	8	-	kHz
Microphone Amp Gain (switchable on/off)		24	26	28	dB
Anti-aliasing Rejection		-	30	-	dB
Power Supply Rejection (1kHz)	PSR	40	-	-	dB
Frequency Response		-0.6	-	0.6	dB
Transition Band		0.45	-	0.6	$F_s$
Stop Band Rejection		70	-	-	dB
VREF Reference Voltage Output		-	2.0	-	V
VCM Voltage Output constant load only, >100 $k\Omega$		-	1.0	-	V
Group Delay (Note 4)		-	1	-	ms
Group Delay Variations vs. Frequency (Note 4)		-	0.0	-	$\mu\text{s}$

- Notes:
1. Bench testing is done with Crystal part CXT8192 driving CLKIN, automated device testing utilizes test system provided clock sources.
  2. Guaranteed by design/characterization.
  3. This is the peak input voltage (in volts) with the mic amp gain set to 0 dB. Peak-to-peak voltage is 2x peak. Input signals will be properly clipped if the peak signal is greater than full scale, but less than 2x full scale.
  4. This group-delay specification is for the ADC only; additional group delay is introduced by the AGC and high-pass filter that is implemented on the CS6403 in software.

**DAC CHARACTERISTICS** ( $T_A = 25\text{ }^\circ\text{C}$ ; All DVDD, AVDD, and PVDD = 5.0V, Digital Input Levels: Logic 0 = 0V, Logic 1 = DVDD; Signal test frequency 1kHz, word rate ( $F_s$ ) = 8kHz, audio signal measurement bandwidth is 20Hz to 20kHz; Microphone amp gain = 0dB; SPKROUT outputs connected to  $8\Omega$  load; CLKIN frequency = 8.192MHz; unless otherwise specified)

Parameter	Symbol	Min	Typ	Max	Units
DAC Resolution		12	-	-	bits
DAC step size error		-	-	$\pm 0.5$	LSB
Instantaneous Dynamic Range (20 Hz - 20 kHz)	IDR	60	72	-	dB
Frequency Response		-0.8	-	+0.6	dB
Programmable Output Level Attenuator Range (Note 5)		-92.2	-	0	dB
Gain Step Size		-	2.49	-	dB
Gain Drift (Note 2)		-	150	-	ppm/ $^\circ\text{C}$
VREF Reference Output Voltage		-	2.0	-	V
VCM Output Voltage constant load only, $>100k\Omega$		-	1.0	-	V
Offset Error		-	25	50	mV
Full Scale Output Voltage (SPKROUT pins) (Note 6)		1.40	1.75	1.93	$V_p$
Common Mode Output Voltage (SPKROUT pins)		-	1.30	-	V
Total Harmonic Distortion at -0.5dBFS level, SPKROUT (Note 9)	THD	-	-	0.8	%
Output Impedance SPKROUT pins		-	0.4	-	$\Omega$
Load Impedance SPKROUT pins		8	-	-	$\Omega$
Output Capacitance		-	15	-	pF
Audible Stop Band Attenuation ( $<20\text{kHz}$ )		68	-	-	dB
Integrated Inaudible Energy ( $>20\text{kHz}$ to $100\text{kHz}$ ) (Note 7)		-	-	30	mVrms
Power Supply Rejection (1kHz)	PSR	40	60	-	dB
Filter Transition Band		0.45	-	0.6	$F_s$
Group Delay (Note 8)		-	1	-	ms

- Notes:
5. Attenuation settings greater than 92.2 dB will cause a full scale input signal to be completely attenuated to zero signal level.
  6. This is the peak differential output voltage. The peak-to-peak signal level on each output pin is equal to the peak differential value.
  7. Assuming an external 43.2 kHz RC output filter.
  8. This group-delay specification is for the DAC only; additional group delay is introduced by the AGC and high-pass filter that is implemented on the CS6403 in software.
  9. Room temperature only.

**PHASE-LOCKED LOOP CHARACTERISTICS** ( $T_A = 25^\circ\text{C}$ ; AVDD, DVDD, and PVDD = +5V; Input Levels: Logic 0 = 0V, Logic 1 = DVDD)

Parameter	Symbol	Min	Typ	Max	Units
PLL acquisition time	$T_{ACQ}$		0.3	1	ms
PLL frequency range		23.35	24.58	25.80	MHz
PLL jitter			200		ps rms
Input ref frequency		1.95	2.048	2.15	MHz
		0.97	1.024	1.08	MHz
		243	256	268	kHz

**DIGITAL CHARACTERISTICS** ( $T_A = 25^\circ\text{C}$ ; AVDD, DVDD, and PVDD = 5V)

Parameter	Symbol	Min	Typ	Max	Units
High-level Input Voltage	$V_{IH}$	DVDD - 1.0	-	-	V
Low-level Input Voltage	$V_{IL}$	-	-	1.0	V
High-level Output Voltage at $I_O = -2.0$ mA	$V_{OH}$	DVDD - 0.3	-	-	V
Low-level Output Voltage at $I_O = +2.0$ mA	$V_{OL}$	-	-	0.3	V
Input Leakage Current (Digital Inputs)	$I_{IN}$	-	-	10	$\mu\text{A}$
Output Leakage Current (High-Z Digital Outputs)		-	-	10	$\mu\text{A}$
Output Capacitance (Note 2)	$C_{OUT}$	-	-	15	pF
Input Capacitance (Note 2)	$C_{IN}$	-	-	15	pF

**ABSOLUTE MAXIMUM RATINGS** (All voltages with respect to 0V)

Parameter	Symbol	Min	Typ	Max	Units
Power Supplies	AVDD DVDD PVDD	-0.3	-	6.0	V
Input Current Except Supply Pins & Driver Pins	$I_{IN}$	-	-	10.0	mA
Short Circuit Current Limit SPKROUT pins (Note 10)	$I_{SC}$	-	-	500	mA
Analog Input Voltage	$V_{INA}$	-0.3	-	AVDD + 0.3	V
Digital Input Voltage	$V_{IND}$	-0.3	-	DVDD + 0.3	V
Ambient Temperature (Power Applied)	$T_{AMAX}$	-55	-	125	$^\circ\text{C}$
Storage Temperature	$T_{STG}$	-65	-	150	$^\circ\text{C}$
ESD using human body model (100pF with series 1.5k $\Omega$ )	$V_{ESD}$	2000	-	-	V

Notes: 10. SPKROUTP or SPKROUTN shorted to ground.

Warning: Operation beyond these limits may result in permanent damage to the device.

Normal operation is not guaranteed at these extremes.

**POWER CONSUMPTION** ( $T_A = 25^\circ\text{C}$ ; All DVDD, AVDD and PVDD = 5.0V; Signal test frequency 1kHz; Word Rate ( $F_s$ ) = 8kHz; SPRKOUT outputs connected to  $8\Omega$  load; Mode 2 SCLK = 256 kHz; unless otherwise specified) Full scale output.

Parameter	Symbol	Min	Typ	Max	Units
Normal Operation Power Dissipation	$P_D$	-	800	-	mW
High-Impedance Output (Note 11)	$P_{NS}$	-	300	-	mW
RESET High	$P_{RH}$	-	55	-	mW
RESET High, clocks halted (Note 12)	$P_{RNC}$	-	15	-	mW
Powerdown Asserted in Software	$P_{PDN}$	-	55	-	mW

Notes: 11. SPKROUT outputs connected to 1 k $\Omega$  load.

12. RESET high, CLKIN grounded (Mode 1) or SCLK grounded (Mode 2), and CLK\_SEL (PIN 15Q, 21L) high to disable PLL.

## RECOMMENDED OPERATING CONDITIONS (All voltages with respect to 0V)

Parameter	Symbol	Min	Typ	Max	Units
DC Power Supplies:	AVDD DVDD PVDD	4.50	5.0	5.50	V
Ambient Operating Temperature	$T_A$	-40		85	$^\circ\text{C}$

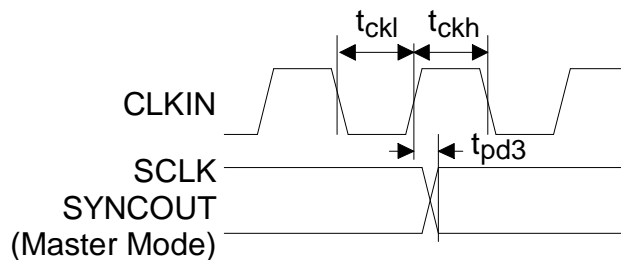

**SCLK & SYNCOUT Output Timing**  
Mode 1 - MASTER

**SWITCHING CHARACTERISTICS** ( $T_A = 25^\circ\text{C}$ ; AVDD and DVDD = +5V, output loaded with 30 pF; Input Levels: Logic 0 = 0V, Logic 1 = DVDD)

Parameter	Symbol	Min	Typ	Max	Units
<b>Mode 1 - MASTER</b>					
Input clock (CLKIN) frequency	CLKIN	7.78	8.192	8.60	MHz
CLKIN low time	$t_{ckl}$	30	-	-	ns
CLKIN high time	$t_{ckh}$	30	-	-	ns
Sample Rate	Fs	-	8	-	kHz
SCLK and SYNCOUT output delay from CLKIN rising	$t_{pd3}$	-	-	50	ns
SCLK duty cycle (Note 12)	$t_{sckw}$	-	50	-	%
SCLK rising to SYNCOUT rising	$t_{sr1}$	-	12	30	ns
SCLK rising to SYNCOUT falling	$t_{sf1}$	-	6	30	ns
SDO delay from SCLK edge	$t_{pd1}$	-	-	70	ns
SDI setup time to SCLK edge	$t_{s1}$	15	-	-	ns
SDI hold time from SCLK edge	$t_{h1}$	10	-	-	ns
SDO to Hi-Z state	$t_{hz}$	-	-	50	ns
SDO to non-Hi-Z bit 1	$t_{nz}$	5	-	-	ns
RESET pulse width high		250	-	-	$\mu\text{s}$
<b>Mode 2 - SLAVE</b>					
Input clock (SCLK) frequency	SCLK	243 0.97 1.95	256 1.024 2.048	268 1.08 2.15	kHz MHz MHz
SCLK low time	$t_{ckl}$	150	-	-	ns
SCLK high time	$t_{ckh}$	150	-	-	ns
SYNCOUT output delay from SSYNC rising	$t_{pdsr}$	-	-	50	ns
SYNCOUT output delay from SSYNC falling	$t_{pdsf}$	-	-	50	ns
Sample Rate	Fs	-	8	-	kHz
SDI/SSYNC setup time to SCLK edge	$t_{s1}$	15	-	-	ns
SDI/SSYNC hold time from SCLK edge	$t_{h1}$	10	-	-	ns
SDO delay from SCLK edge	$t_{pd1}$	-	-	70	ns
SDO to Hi-Z state bit 16/8	$t_{hz}$	-	-	50	ns
SDO to non-Hi-Z bit 1	$t_{nz}$	5	-	-	ns
RESET pulse width high		250	-	-	$\mu\text{s}$

Notes: 12. When the CS6403 is in master mode (SSYNC and SCLK outputs), the SCLK duty cycle is 50%.  
The period of SCLK is 4/CLKIN.

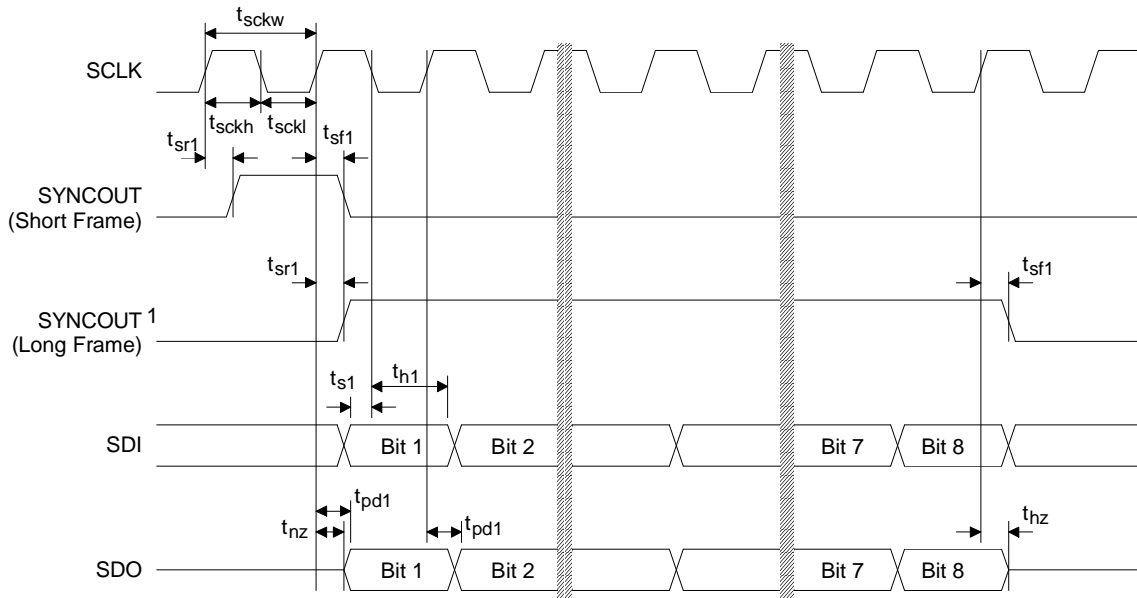

Note: 1. SYNCOUT is long frame when SFROME = 1.

**Master Mode Serial Port Timing  
(Mode 1)**

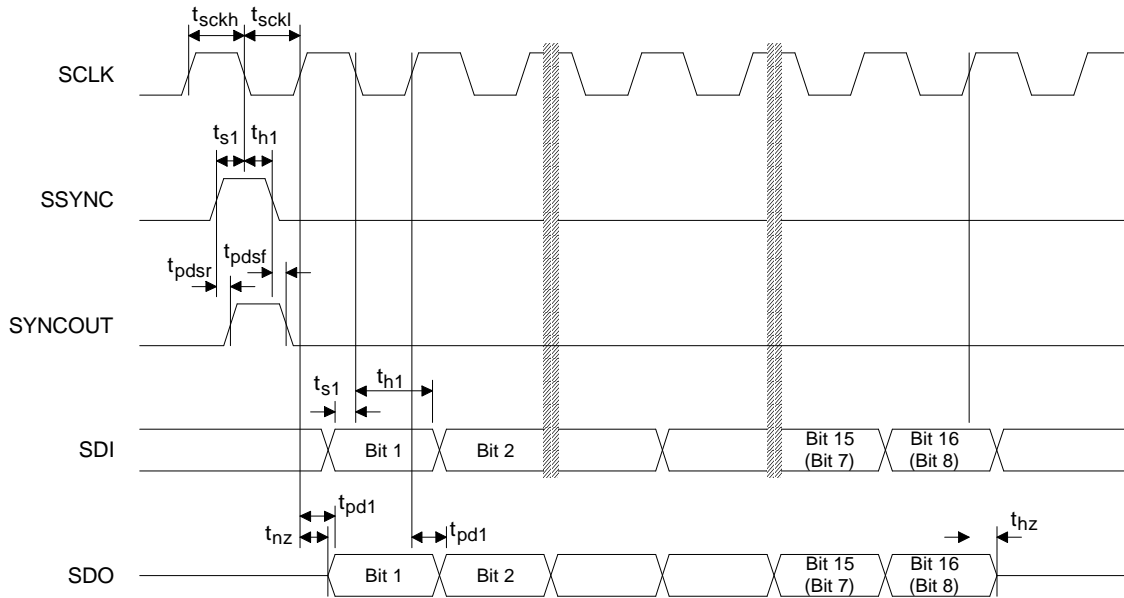

**Slave Mode Serial Port Timing  
(Mode 2)**

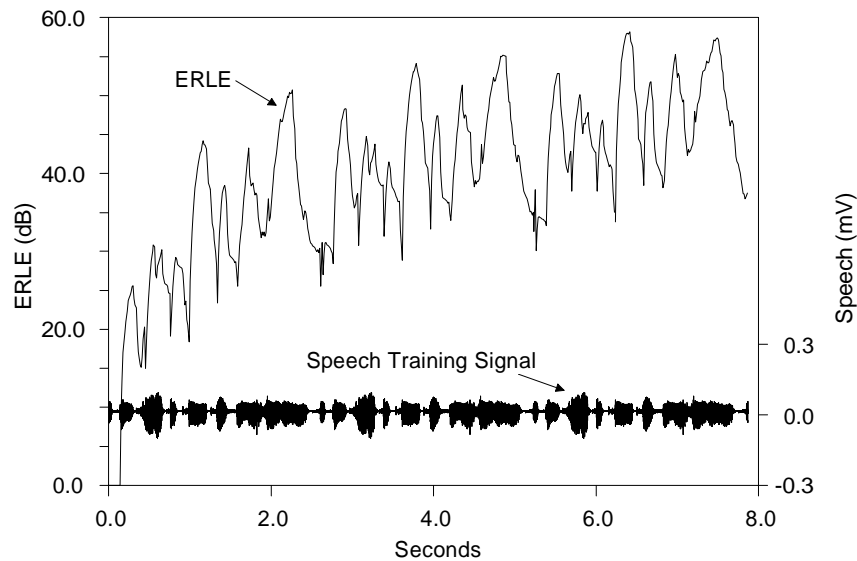

**Figure 1. Typical ERLE Convergence Characteristics**

**Echo Canceller Characteristics**

The typical Echo Return-Loss Enhancement (ERLE) convergence characteristics for the CS6403 are illustrated in the above diagram under the following conditions:

- Echo-canceller length: 512 taps
- Echo-canceller initial conditions: zeroed filter taps, updates disabled until t=0.125s
- Sampling rate: 8 kHz
- Echo path (including microphone, speaker, and amplifiers):
  - spectrally flat
  - linear
  - duration < 64 ms
  - noise free
  - time invariant
- Near-end high-pass filter: enabled
- Pre-emphasis filter: enabled
- Graded-beta profile: 64 echo-canceller filter taps processed per 2x reduction in update gain
- Training signal: speech, full scale
- Unlimited S/(N+D) on linear ADC

Note: Many of these conditions may be significantly different in real applications, resulting in significantly different measured ERLE performance.

**OVERVIEW**

In hands-free speakerphones, the signal from the far end may echo about the near-end environment and then be received at the near-end microphone. When heard at the far end, this echo signal can be very annoying, particularly if the signal is delayed by transmission or signal-processing delays.

Voice switching is a particularly simple technique for eliminating this echo, but since it imposes half-duplex communication, it seriously compromises conversation quality.

Echo cancellation can provide high-quality, full-duplex communication, but typically must be implemented using expensive digital signal-processing hardware.

*Echo Cancellation in the CS6403*

The CS6403 provides high-quality echo cancellation at low cost. This breakthrough in cost/performance is made possible on the CS6403 by custom, application-optimized processing blocks, which are integrated on a single die, as shown in Figure 2.

One of these processing blocks is the AFP (Adaptive Filter Processor). This block implements a 512-tap AFIR (Adaptive Finite Impulse-Response) filter which is updated using an enhanced least-mean squared (LMS) algorithm. At a sampling rate of 8 kHz, it can cancel up to 64 ms of echo. By default, 10 ms of the available 64 ms are allocated to a network canceller (NEC), and the remaining 54 ms are allocated to an acoustic echo canceller (AEC).

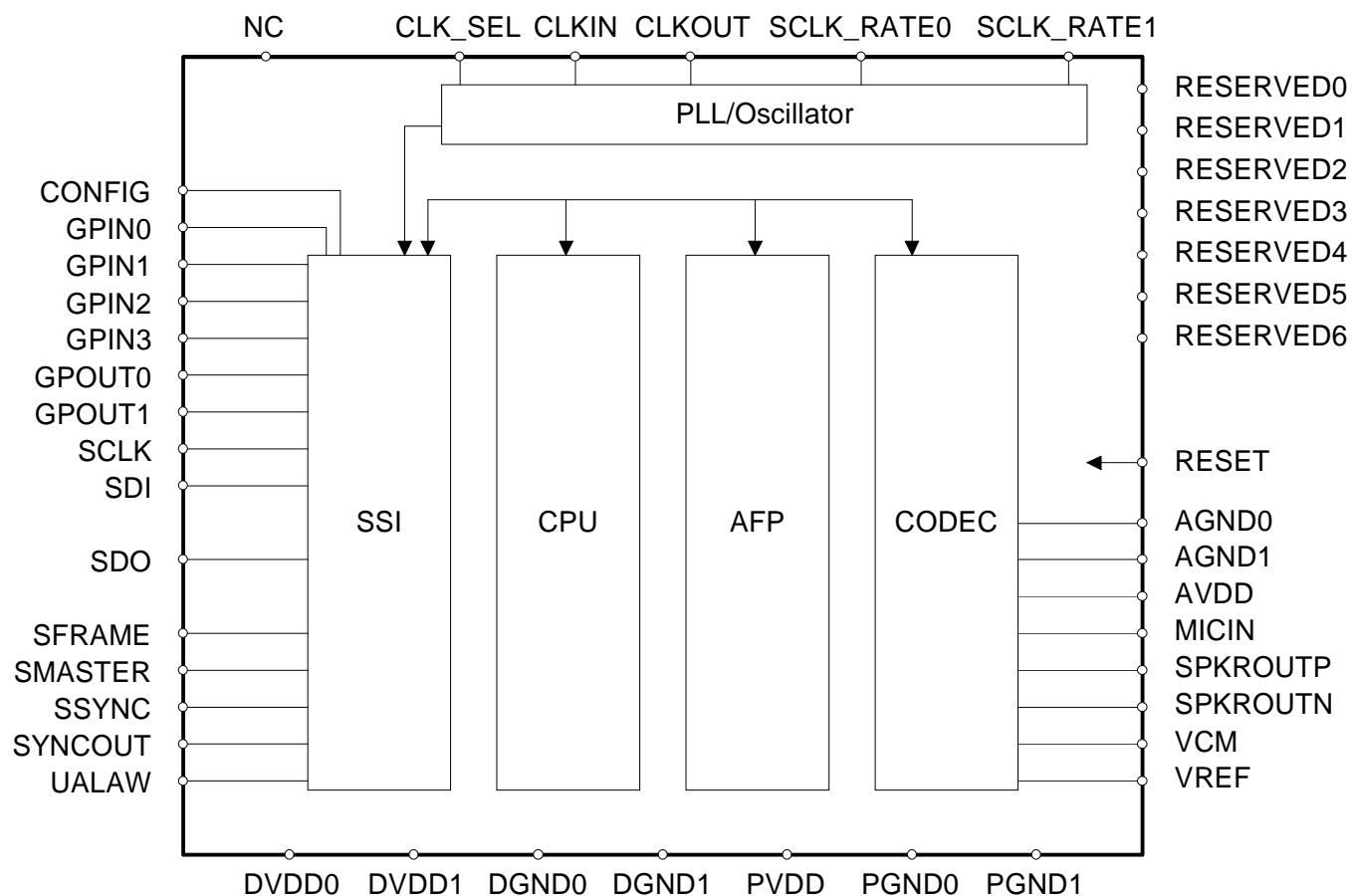

**Figure 2. CS6403 Internal Block Diagram**

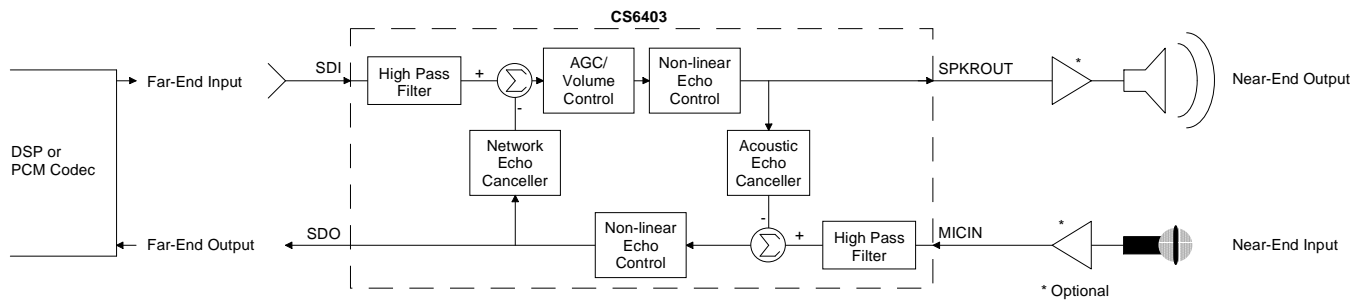

**Figure 3. Functional Diagram**

The Central Processing Unit (CPU) does all the other miscellaneous processing, like update control and double talk detection. This processing has a critical influence on overall echo-cancellation performance. Double-talk detection is a particularly important part of this processing. Double-talk detection and other algorithms were carefully developed and validated at Crystal under real-world conditions.

To increase the CS6403's echo return-loss enhancement (ERLE), supplemental echo suppression is used. A sophisticated voice-detection algorithm is used to reduce echo with minimal impact on conversation quality, assuring the highest quality conversation.

Figure 3 describes the functional behavior of the CS6403 in a typical application. Digital data from the far-end interface comes into SDI of the CS6403 where it is acted upon by the various algorithms running in the CPU. First, a High-Pass Filter eliminates DC offset and low frequency noise before sending the far-end input data onto the summing node for the network echo canceller. Assuming there is no speech from the near-end, the signal after the summing node is unaffected.

The signal then passes on to the AGC/Volume Control block where the signal level is boosted, if necessary. The volume control is implemented in part by the AGC (for more details, see the section entitled "Embedded Signal Processing Functions").

The signal then passes on to the Non-linear Echo Control block which controls the half-duplex failsafe and the supplementary echo suppressor which act to enhance and supplement the performance of the echo canceller.

The signal after this block is then fed to both the speaker output and the input to the acoustic echo canceller (implemented by the AFP). The speaker output couples to the microphone input by various echo paths. The signal received at the microphone is then filtered and sent on to the summing node of the Acoustic Echo Canceller. The Acoustic Echo Canceller constructs a model of the echo paths between the speaker and microphone and processes its input signal with its digital representation of the echo paths. As such, its output should very closely match the input from the microphone and so the output from the summing node should be a very small signal, which is referred to as the "error signal." This error signal is fed back to the echo canceller to let it adapt its performance should there be a change in the echo path.

The Non-linear Echo Control block following the summing node further attenuates any vestiges of signal received at the microphone that originated from the speaker. This signal is then sent to the far-end output by SDO as well as to the input of the Network Echo Canceller, where a function similar to that performed by the Acoustic Echo Canceller is performed.

### Analog Interface

The codec block provides an analog-to-digital converter (ADC) and a digital-to-analog converter that can be connected directly to a microphone and a speaker, respectively.

The output of the microphone should be low-pass filtered, then AC-coupled to the audio input, MICIN. A 26 dB gain stage is included in the CS6403 at the ADC input to amplify the microphone signal. However, this gain stage may be bypassed in modes in which a line-level source is connected to the CS6403 instead of a microphone. The CS6403 also includes a speaker driver, which can drive an 8Ω speaker directly, or alternatively, it can drive a high-impedance differential input on an external amplifier.

With the 26 dB gain stage on, the fullscale input for the MICIN pin is 100mV peak-to-peak. Any signal over 100mV peak-to-peak will clip the input to the ADC. With the gain stage off, a 2V peak-to-peak signal is the maximum allowed. The fullscale output voltage from the DAC is 1.75V peak-to-peak single-ended, or 3.5V peak-to-peak differentially.

It is very important to not clip signals anywhere in the system. An echo canceller can only remove echo that passes through a linear, time invariant path. Echo that passes through a non-linearity (like clipping) will not be removed by the echo canceller.

Both the DAC and ADC paths are bandlimited as a function of sampling rate. At a sampling rate of 8 kHz, the paths are limited to 0-3600 Hz.

### Synchronous Serial Interface

The Synchronous Serial Interface (SSI) provides a data and control interface to the CS6403. The SSI can be connected to an external network codec for applications like speakerphones or to a DSP for high-end applications like video teleconferencing.

Depending on the state of the SMASTER (PIN 42Q, 4L) pin at RESET, the CS6403 can operate as either a system timing master or slave. As a master, the serial clock pin (SCLK) is an output. As a system timing slave, SCLK must be driven by an external source. When SMASTER is high, the SCLK output frequency is a fixed 2.048 MHz derived from the 8.192 MHz crystal oscillator connected across CLKIN and CLKOUT. When SMASTER is low, internal timing is generated by the Phase Locked Loop (PLL), which uses SCLK's input as a timing reference, so no external crystal is necessary. In slave timing mode, SCLK can be driven at 256 kHz, 1.024 MHz, or 2.048 MHz. The CS6403 is informed of the SCLK rate via the SCLK\_RATE0 (PIN 29Q, 35L) and SCLK\_RATE1 (PIN 30Q, 36L) pins.

Table 1 shows the various options for SCLK.

SMASTER	SCLK_RATE1	SCLK_RATE0	SCLK		
			Clock Rate	I/O	mode
0	0	0	256 kHz	I	slave
0	0	1	undefined		
0	1	0	1.024 MHz	I	slave
0	1	1	2.048 MHz	I	slave
1	0	0	undefined		
1	0	1	undefined		
1	1	0	undefined		
1	1	1	2.048 MHz	O	master

**Table 1. Clock Options**

Configuration		SFRAME	SMASTER	CONFIG
<u>Mode 1:</u>	Master Interface (e.g. CODEC↔CS6403)			
Application:	Low-cost speaker phone			
1.1:	Short-Frame Mode	0	1	0
1.2:	Long-Frame Mode	1	1	0
<u>Mode 2:</u>	Slave Interface (e.g. DSP↔CS6403)			
Application:	Digital cellular			
2.1:	16-bit Mode	0	0	1
2.2:	8-bit Mode	0	0	0

**Table 2. CS6403 Configurations**

**Mode Selection**

The behavior of the CS6403 is controlled by configuration-control input pins. The behavior of the CS6403 for each possible state of these control signals is illustrated in Table 2.

As indicated in Table 2, the CS6403 has two basic operating modes. These operating modes are illustrated in Figure 4.

The simplest operating mode is Mode 1. This operating mode is useful in applications where the data link to the far end is analog, as in analog cellular hands free, or in analog speaker phones. The SSI is the system timing master in Mode 1. Long or short framing signals can be generated. Word length is always 8 bits.

Mode 2 is useful in applications where the data link to the far end is digital, as in digital cellular hands free, or in digital (ISDN) speaker phones. The SSI is the system timing slave in Mode 2. Only short framing pulses are accepted. Word length can be 8 or 16 bits. Mode 2 allows access to control registers in 16-bit Mode.

**States of Operation**

**Reset**

Reset may be asserted either by setting the RESET (PIN 41Q, 3L) pin high, or by setting the Reset bit in Synchronous Serial Interface Control Register 0 (RST: SSI\_CR0.11). The only functional difference between these two operations is that setting the RESET pin clears the RST bit. During Reset, all chip functions are halted ex-

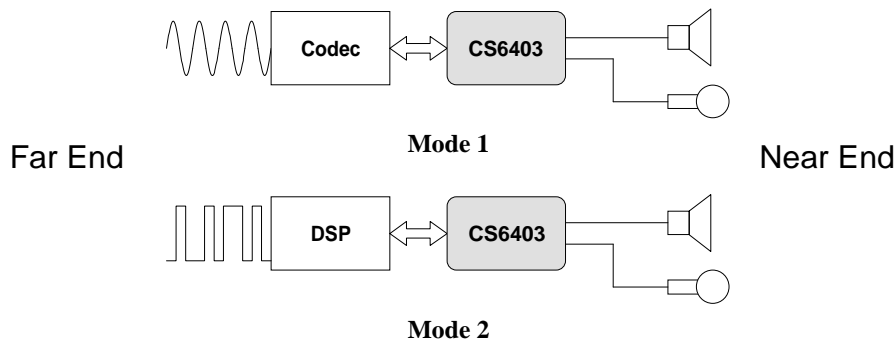

**Figure 4. Operating Modes**

cept for the SSI, though writes to any control bit except RST are ignored. Power down is not enabled.

Upon exiting Reset, control registers and RAM are cleared, and then control constants are loaded into Data RAM from the Program ROM.

*Power-Down*

Power Down is initiated by setting the Sleep bit in SSI Control Register 0 (SLP: SSI\_CR0.10). In Power Down, the CPU and the AFP are powered down, but the SSI and the Codec are still operational. Power Down is only accessible in Mode 2 (16-bit).

Since the SSI and the Codec are active during Power Down, it is possible to serially transfer

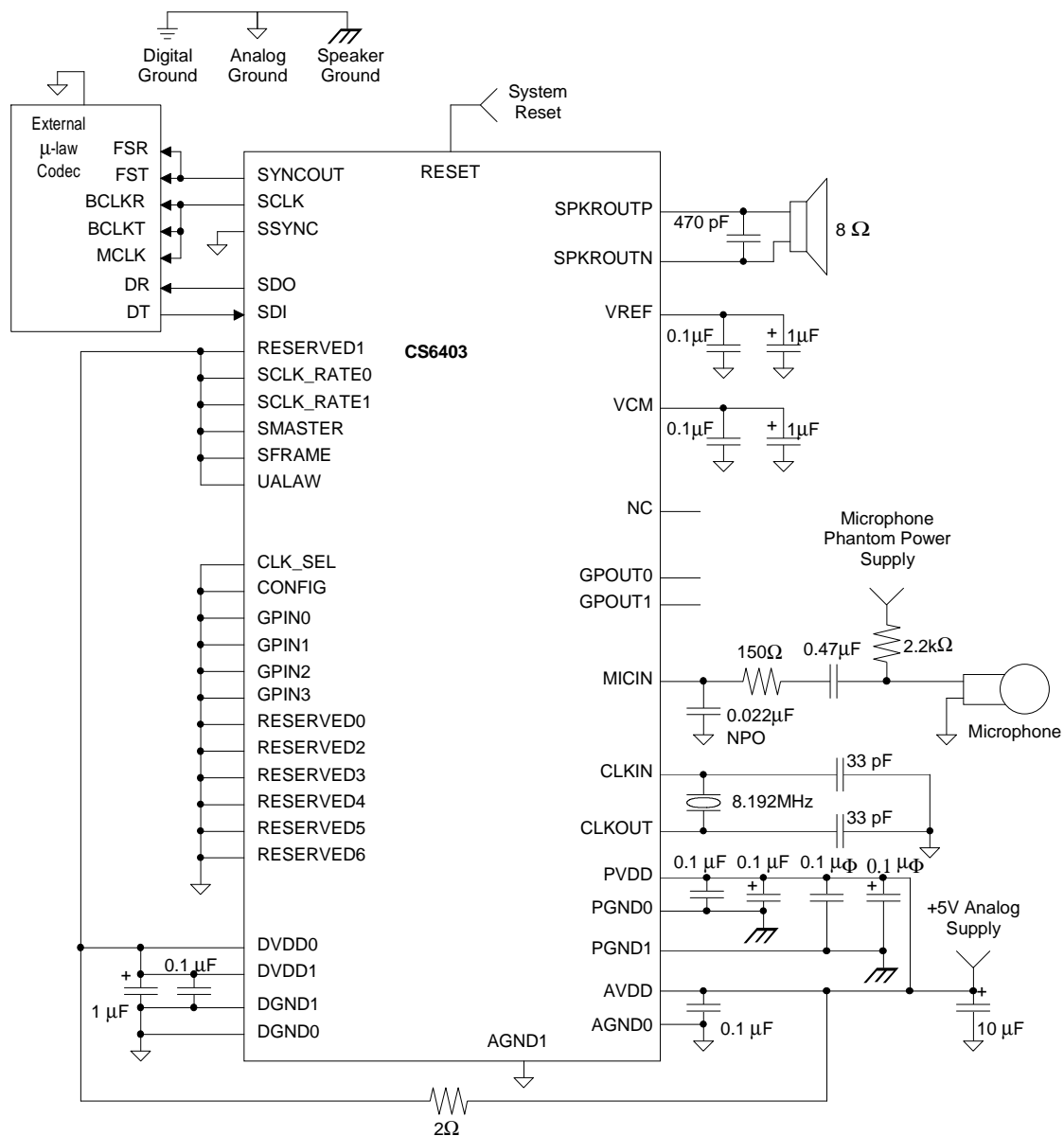

**Figure 5. External Mu-law Codec Connection Diagram**

audio and control data while SLP is asserted, bypassing the CPU and AFP. Note, however, that since the CPU is powered down, no scaling is performed on the ADC input, no echo is cancelled, and audio data is not companded.

**Using the CS6403**

***Interfacing as a Master to an external codec (Mode 1)***

In applications like speakerphones, it is possible to connect the CS6403 directly to an external network codec. An example circuit is shown in Figure 5.

In this application, SYNCOUT and SCLK are sourced by the CS6403 (i.e., SMASTER=1), and CLKIN is generated by connecting a crystal between CLKOUT and CLKIN. The timing for these signals is illustrated in Figure 6.

Audio-data samples in Mode 1 are 8 bits and are  $\mu$ -law or A-law companded depending on the state of the UALAW pin (PIN 13Q, 19L). No control information can be transferred in Mode 1, so there is no control/data steering bit. Also note that since control information cannot be transferred, the default settings of the control registers established after Reset are used.

In Mode 1, 80 echo-canceller taps (out of the available 512) are permanently allocated to network-echo cancellation (see Figure 3).

**Mode 1.1 (Short-Frame Mode)**

SFRAME=0; SSYNC = 0

SCLK (out)

SYNCOUT (out: 8kHz)

SDI (in)

SDO (out)

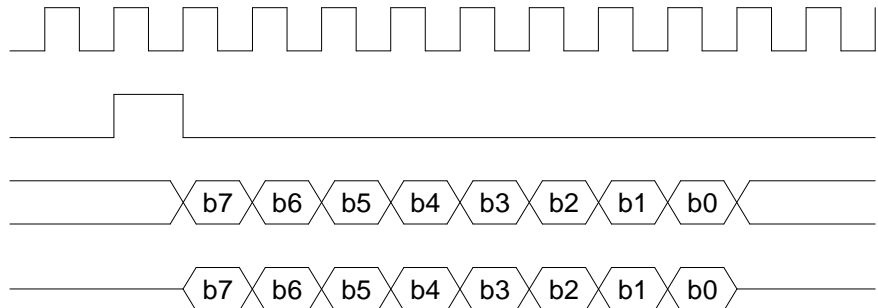

**Mode 1.2 (Long-Frame Mode)**

SFRAME=1; SSYNC = 0

SCLK (out)

SYNCOUT (out: 8kHz)

SDI (in)

SDO (out)

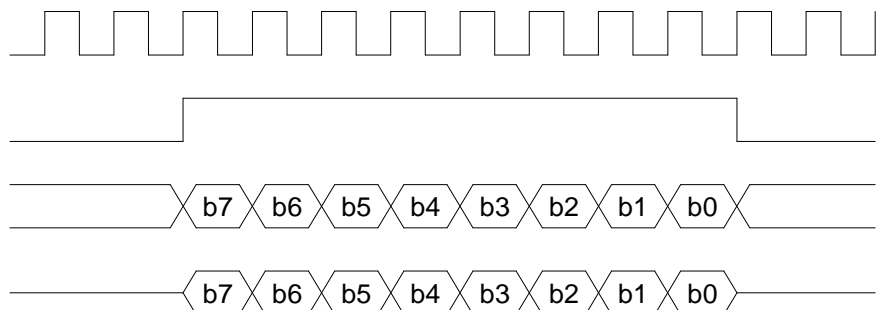
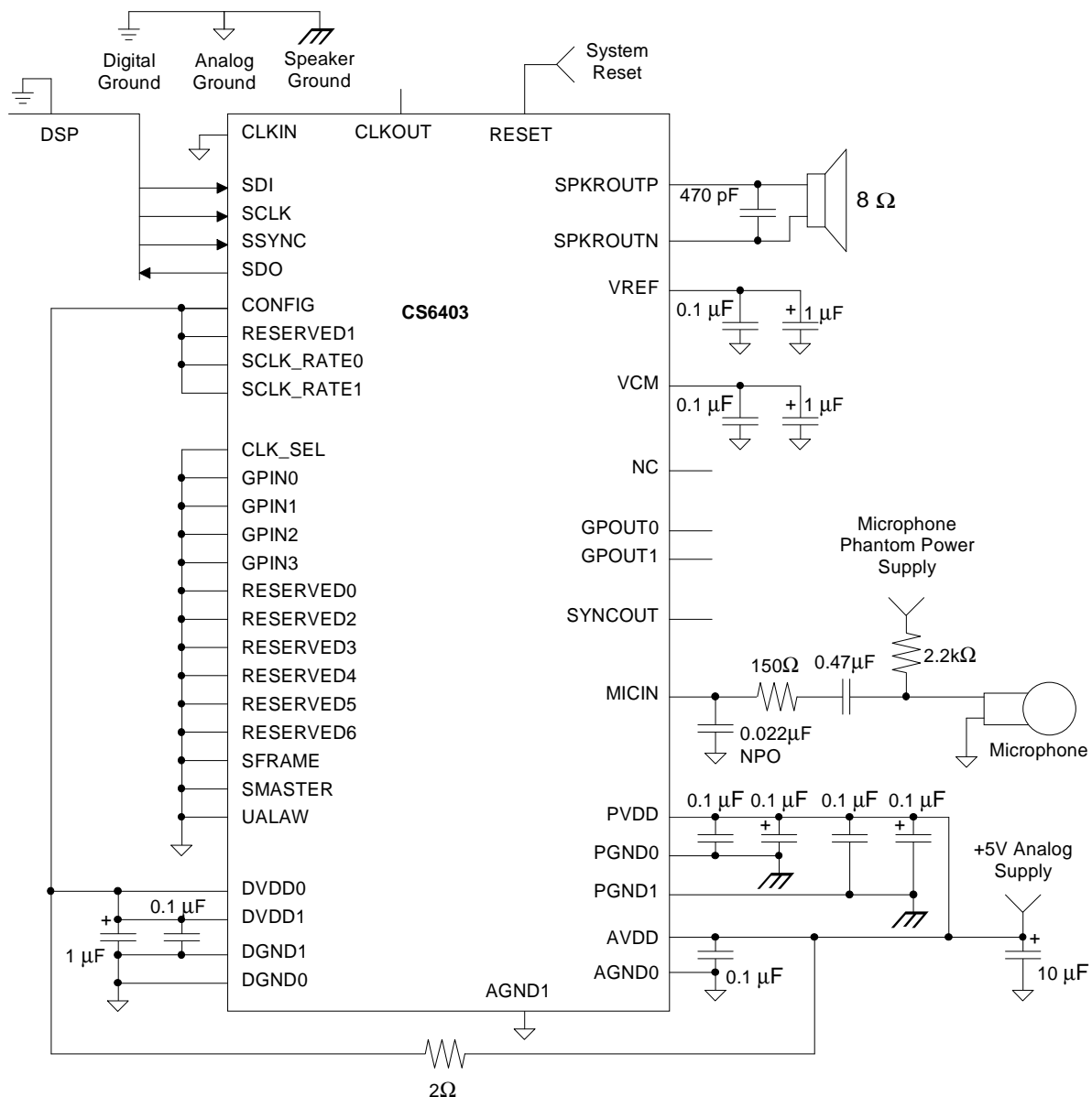

**Figure 6. External-Codec Mode Timing (Mode 1)**

**Interfacing as a Slave to an external DSP (Mode 2)**

When interfacing to an external DSP (Mode 2), the CS6403 is configured as a slave to the DSP: SSI; i.e., SCLK, and SSYNC signals are provided to the CS6403 by the DSP. An example of the interface circuitry is shown in Figure 7.

In this case, the DSP sends a single start-of-frame pulse to the SSYNC input one SCLK period before the start of a data frame. Since there is only one SSYNC input, every data frame includes both a data read from the CS6403 and a data write to the CS6403. The behavior of the serial interface is illustrated in Figure 8.



**Figure 7. DSP Connection Diagram (Mode 2)**

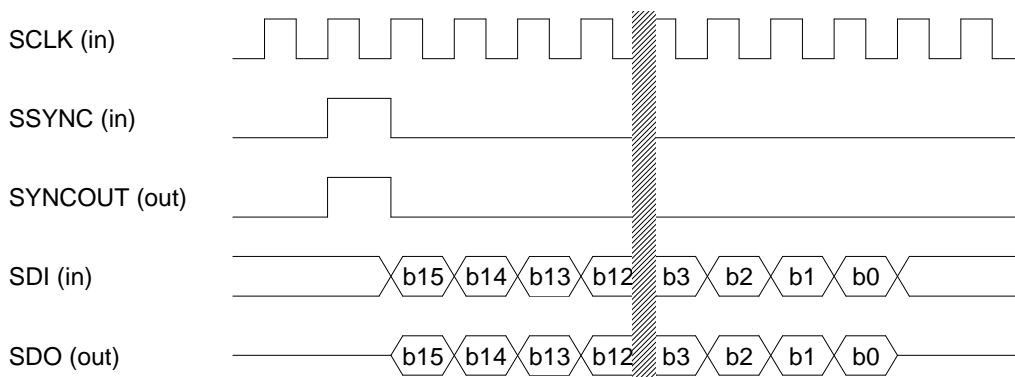

**Figure 8. Serial Port Timing for Mode 2 (16-bit) - SLAVE**

**Mode 2 (8-bit) Slave**

Mode 2 (8-bit) provides a slaved SSI which may be needed for 8-bit companded audio interfacing, as is the case with many ISDN transceivers. Mode 2 (8-bit) timing is similar to Mode 2 (16-bit) timing, but the serial data is 8-bit companded, with the type of companding determined by the state of the UALAW pin. All 8 bits are used for audio, so no steering bit is necessary, and consequently, no control information can be transferred in this mode.

Mode 2 (8-bit) is selected by setting CONFIG low, as opposed to high in Mode 2 (16-bit). See Table 2 for more details. SCLK frequency is determined by the SCLK\_RATE1 and SCLK\_RATE0 pins as given by Table 1. As in Mode 2 (16-bit), the CS6403 will phase-lock to the SCLK provided to it and derive its own timing from it.

**Mode 2 (16-bit) Slave**

Setting CONFIG high selects Mode 2 (16-bit). When a DSP is connected to a CS6403 in Mode 2 (16-bit), the DSP can reconfigure the CS6403 by writing to the CS6403's control registers via the SSI. To multiplex both data and control on one serial interface, a steering bit is used. The first bit sent (MSB) by the DSP determines whether a word is control or data, as shown in Table 3.

If STR, the Steering Bit (b15), is zero, then the data transferred on the Serial Interface is audio data. Note that since a transfer typically consists of 16 bits, this allows 15-bit precision for input audio data. Output audio data remains in 16-bit precision.

Companded audio data is treated differently than 16-bit data. Input companded audio data has eight zeroes followed by the 8-bit companded data. Output companded audio data is formatted such that 8-bit data is followed by eight zeroes.

If STR is one, the word transferred on the Serial Interface is control information. If the RNW bit is a zero, the word written by the external DSP is stored by the CS6403 in the indicated destination register, and simultaneously, the state of the destination register before the write is read back into the DSP. If RNW is one, the data written by the external DSP is ignored. The state of the destination register is read back to the DSP.

Note that only one control word or one data word may be transferred in a sample time, meaning that no audio data is transferred in sample times where control information is transferred. In such sample times, the CS6403 will reuse (double-sample) the audio data from the previous sample time. As a result, to minimize distortion of the audio signal, control transactions should be made infrequently.

The CS6403 requires one sample time to effect a write to a control register. As a result, a control-word write should not be followed in the next control word with a read to the same control word. There should be at least one intervening sample time prior to the next control word read to that control word.

The following table defines the four registers accessible by the serial interface in 16-bit modes. These registers are accessed by setting b15 high. The state of b14 indicates whether the register access operation is a read (high) or a write (low). Bits b13 and b12 together address the register as follows:

**Control Register Definitions**

The CS6403 has four control registers that are accessible via the SSI, which allow a user to monitor and control the behavior of the CS6403. Note that these registers are accessible only in Mode 2 (16-bit). Some visibility and control is provided by the GPIN and GPOUT pins (see PIN DESCRIPTIONS).

<u>b13 : b12</u>	<u>Register</u>
00	SSI_CR0
01	SSI_CR1
10	SSI_CR2
11	(reserved)

Note that CR0 is different from the other three control registers, in that CR0 is read by the CS6403 CPU only at reset. Also, CR0 may be changed via a serial control operation only immediately after the control word "0x8400" is written to the CS6403 (which puts the CS6403 into "sleep" mode).

**Input Companded Audio Word (8-bit)**

<b>b7</b>	<b>b6</b>	<b>b5</b>	<b>b4</b>	<b>b3</b>	<b>b2</b>	<b>b1</b>	<b>b0</b>
-----------	-----------	-----------	-----------	-----------	-----------	-----------	-----------

**Output Companded Audio Word (8-bit)**

<b>b7</b>	<b>b6</b>	<b>b5</b>	<b>b4</b>	<b>b3</b>	<b>b2</b>	<b>b1</b>	<b>b0</b>
-----------	-----------	-----------	-----------	-----------	-----------	-----------	-----------

**Input Companded Audio Word (16-bit)**

<b>0</b>	<b>0</b>	<b>0</b>	<b>0</b>	<b>0</b>	<b>0</b>	<b>0</b>	<b>0</b>	<b>0</b>	<b>b7</b>	<b>b6</b>	<b>b5</b>	<b>b4</b>	<b>b3</b>	<b>b2</b>	<b>b1</b>	<b>b0</b>
----------	----------	----------	----------	----------	----------	----------	----------	----------	-----------	-----------	-----------	-----------	-----------	-----------	-----------	-----------

**Output Companded Audio Word (16-bit)**

<b>b7</b>	<b>b6</b>	<b>b5</b>	<b>b4</b>	<b>b3</b>	<b>b2</b>	<b>b1</b>	<b>b0</b>	<b>0</b>	<b>0</b>	<b>0</b>	<b>0</b>	<b>0</b>	<b>0</b>	<b>0</b>	<b>0</b>
-----------	-----------	-----------	-----------	-----------	-----------	-----------	-----------	----------	----------	----------	----------	----------	----------	----------	----------

**Input Linear Audio Word (16-bit)**

<b>0</b>	<b>b14</b>	<b>b13</b>	<b>b12</b>	<b>b11</b>	<b>b10</b>	<b>b9</b>	<b>b8</b>	<b>b7</b>	<b>b6</b>	<b>b5</b>	<b>b4</b>	<b>b3</b>	<b>b2</b>	<b>b1</b>	<b>b0</b>
----------	------------	------------	------------	------------	------------	-----------	-----------	-----------	-----------	-----------	-----------	-----------	-----------	-----------	-----------

**Output Linear Audio Word (16-bit)**

<b>b15</b>	<b>b14</b>	<b>b13</b>	<b>b12</b>	<b>b11</b>	<b>b10</b>	<b>b9</b>	<b>b8</b>	<b>b7</b>	<b>b6</b>	<b>b5</b>	<b>b4</b>	<b>b3</b>	<b>b2</b>	<b>b1</b>	<b>b0</b>
------------	------------	------------	------------	------------	------------	-----------	-----------	-----------	-----------	-----------	-----------	-----------	-----------	-----------	-----------

**Input Control Word (16-bit)**

<b>1</b>	<b>RNW</b>	<b>a1</b>	<b>a0</b>	<b>b11</b>	<b>b10</b>	<b>b9</b>	<b>b8</b>	<b>b7</b>	<b>b6</b>	<b>b5</b>	<b>b4</b>	<b>b3</b>	<b>b2</b>	<b>b1</b>	<b>b0</b>
----------	------------	-----------	-----------	------------	------------	-----------	-----------	-----------	-----------	-----------	-----------	-----------	-----------	-----------	-----------

**Output Control Word (16-bit)**

<b>1</b>	<b>RNW</b>	<b>a1</b>	<b>a0</b>	<b>b11</b>	<b>b10</b>	<b>b9</b>	<b>b8</b>	<b>b7</b>	<b>b6</b>	<b>b5</b>	<b>b4</b>	<b>b3</b>	<b>b2</b>	<b>b1</b>	<b>b0</b>
----------	------------	-----------	-----------	------------	------------	-----------	-----------	-----------	-----------	-----------	-----------	-----------	-----------	-----------	-----------

**Table 3. Audio and Control Data Format for Mode 2**

After reset (or after CR0 is written), at least four data words must be written to the CS6403 before another control-word access may be executed. For example, the following serial-data sequence will reset the CS6403, set CR0 to a new value, and initialize CR1 and CR2:

<b>hex data</b>	<b>intent</b>
8800	Software reset
8000	Release reset
8400	Enter "sleep" mode
8[0-3]XX	Update CR0 (with "[0-3]XX")
0000	dummy data 1
0000	dummy data 2
0000	dummy data 3
0000	dummy data 4
9XXX	Update CR1
AXXX	Update CR2
0000	First real data item

In the following tables describing each bit of the control registers, the bit names of each 12-bit register are at the top of the page. The Reset state of each register is shown immediately below the bit names at the top of the page. The Reset state is also noted by an "R" beside the appropriate value in the "value" column.

**Register SSI\_CR0**

B11	B10	B9	B8	B7	B6	B5	B4	B3	B2	B1	B0
<b>RST</b>	<b>SLP</b>	<b>AGCRD</b>	<b>NECD</b>	<b>FHPD</b>	<b>NHPD</b>	<b>CE</b>	<b>PED</b>	<b>GBC1</b>	<b>GBC0</b>	<b>AECB1</b>	<b>AECB0</b>
0	0	0	0	0	0	0	0	1	0	1	0

This register is read from the SSI by the CPU only upon exit from Reset and Sleep. This register is cleared at reset except for B3-B0 (see below).

BIT	NAME	VALUE		FUNCTION
RST	Reset	0	<i>R</i>	Normal operation.
		1		Control registers and RAMs are cleared, and then control constants are loaded into Data RAM. SSI is still operational, though writes to any control bit except RST are ignored.
SLP	Sleep	0	<i>R</i>	Normal operation.
		1		The CPU and AFP on the CS6403 are powered down. Control registers and RAMs are unaffected. Serial Data transactions that occur during power down are transferred directly between the SSI and the codec, bypassing the CPU. As a result, echo is passed uncanceled.
AGCRD	AGC-Rescale Disable	0	<i>R</i>	SPKROUT volume is scaled to full-scale after peak-limiter.
		1		SPKROUT signal is peak-limited version of far-end input.
NECD	NEC Disable	0	<i>R</i>	10 ms of the available 64 ms of EC taps are allocated by default to network echo cancellation.
		1		No taps are allocated to network echo cancellation.
FHPD	FE_IN High-Pass Disable	0	<i>R</i>	A high-pass filter $((1-D)/(1-0.75D))$ is inserted in the far-end input signal path.
		1		This filter is bypassed.
NHPD	NE_IN High-Pass Disable	0	<i>R</i>	A high-pass filter $((1-D)/(1-0.75D))$ is inserted in the near-end input signal path.
		1		This filter is bypassed.
CE	Companding Enable	0	<i>R</i>	Data in 16-bit data modes is linear (i.e., not companded).
		1		b15 is still used as the steering bit, but if b15=0, the least significant 8 bits are companded data.
PED	Pre-Emphasis Disable	0	<i>R</i>	A pre-emphasis filter is placed before the input to the adaptive filter.
		1		This filter is bypassed.

"R" indicates value after Reset

**Register SSI\_CR0 (cont.)**

BIT	NAME	VALUE	FUNCTION										
GBC1 GBC0-	Graded-Beta Count	00 01 10 11	Graded-Beta Count - These bits control the rate at which the update gain decays in the AEC as the adaptive-filter taps are updated in a particular sample time. For each setting below, some number of taps are processed, after which the update gain is divided by two. The possible settings are given below: <table style="margin-left: auto; margin-right: auto;"> <thead> <tr> <th><u>Taps Processed</u></th> <th><u>Equivalent path-decay rate</u></th> </tr> </thead> <tbody> <tr> <td>512</td> <td>0 dB/ms</td> </tr> <tr> <td>64</td> <td>0.75 dB/ms</td> </tr> <tr> <td>128</td> <td>0.38 dB/ms</td> </tr> <tr> <td>256</td> <td>0.19 dB/ms</td> </tr> </tbody> </table>	<u>Taps Processed</u>	<u>Equivalent path-decay rate</u>	512	0 dB/ms	64	0.75 dB/ms	128	0.38 dB/ms	256	0.19 dB/ms
<u>Taps Processed</u>	<u>Equivalent path-decay rate</u>												
512	0 dB/ms												
64	0.75 dB/ms												
128	0.38 dB/ms												
256	0.19 dB/ms												
AECB1 AECB0	AEC Beta	00 01 10 11	These bits scale the adaptive filter update gain that is present at the start of each sample time. <table style="margin-left: auto; margin-right: auto;"> <thead> <tr> <th><u>Update Gain</u></th> </tr> </thead> <tbody> <tr> <td>0.25</td> </tr> <tr> <td>0.5</td> </tr> <tr> <td>1.0</td> </tr> <tr> <td>2.0</td> </tr> </tbody> </table>	<u>Update Gain</u>	0.25	0.5	1.0	2.0					
<u>Update Gain</u>													
0.25													
0.5													
1.0													
2.0													

"R" indicates value after Reset

Recommended settings for D3-D0:

0001	--No graded beta
0111	--"dead" room/car; 0.75 dB/ms path decay
1010	--medium room; (default) 0.28 dB/ms path decay
1100	--large (or "live") room; 0.19 dB/ms decay

**Register SSI\_CR1**

B11	B10	B9	B8	B7	B6	B5	B4	B3	B2	B1	B0
<b>CB</b>	<b>AGCD</b>	<b>res</b>	<b>res</b>	<b>CAL</b>	<b>GADCI</b>	<b>res</b>	<b>res</b>	<b>NCC</b>	<b>HDD</b>	<b>SD</b>	<b>ACC</b>
0	0	0	0	0	0	0	0	0	0	0	0

This register is read/written by the CPU every sample time. This register is cleared at Reset by the SSI.

BIT	NAME	VALUE		FUNCTION
CB	Codec Bypass	0	<i>R</i>	Normal operation.
		1		Codec is bypassed by the CPU to facilitate test.
AGCD	AGC Disable	0	<i>R</i>	Normal operation.
		1		AGC is disabled. Will affect volume control.
res	Reserved for test	0	<i>R</i>	Must be 0.
res	Reserved for test	0	<i>R</i>	Must be 0.
CAL	Codec Analog Loopback	0	<i>R</i>	Normal operation.
		1		Connect ADC to DAC internally.
GADCI	Ground ADC Input	0	<i>R</i>	Normal operation.
		1		ADC input is grounded to facilitate test.
res	Reserved for test	0	<i>R</i>	Must be 0.
res	Reserved for test	0	<i>R</i>	Must be 0.
NCC	NEC Coefficient Clear	0	<i>R</i>	Normal operation.
		1		The network canceller coefficients are cleared.
HDD	Half-Duplex Disable	0	<i>R</i>	Normal operation.
		1		Half-duplex mode, which is normally used during convergence, is disabled.
SD	Suppression Disable	0	<i>R</i>	Normal operation.
		1		Supplementary suppression in the transmit path, which normally operates in conjunction with the echo cancellers, is disabled.
ACC	AEC Coefficient Clear	0	<i>R</i>	Normal operation.
		1		The acoustic canceller coefficients are cleared.

"R" indicates value after Reset

**Register SSI\_CR2**

B11	B10	B9	B8	B7	B6	B5	B4	B3	B2	B1	B0
<b>PDC</b>	<b>PDSD</b>	<b>MGD</b>	<b>res</b>	<b>res</b>	<b>res</b>	<b>res</b>	<b>res</b>	<b>AV3</b>	<b>AV2</b>	<b>AV1</b>	<b>AV0</b>
0	0	0	0	0	0	0	0	0	0	0	0

This register is cleared at Reset by the SSI. This register is read/written by the CPU every sample time.

<b>BIT</b>	<b>NAME</b>	<b>VALUE</b>		<b>FUNCTION</b>
PDC	Power Down Codec	0 1	<i>R</i>	Normal operation. The entire codec is powered down.
PDSD	Power Down Speaker Driver	0 1	<i>R</i>	Normal operation. Only the speaker driver in the codec is powered down.
MGD	Microphone 26 dB Gain Disable	0 1	<i>R</i>	Normal operation. The 26 dB microphone preamp is bypassed.
res	Reserved for test	00000	<i>R</i>	Must be 00000.
AV3-AV0	ADC Volume	0000 . . 1111	<i>R</i>	ADC volume control is implemented in the CPU, with the attenuation being -3 dB times the ADC-volume value.

"R" indicates value after Reset

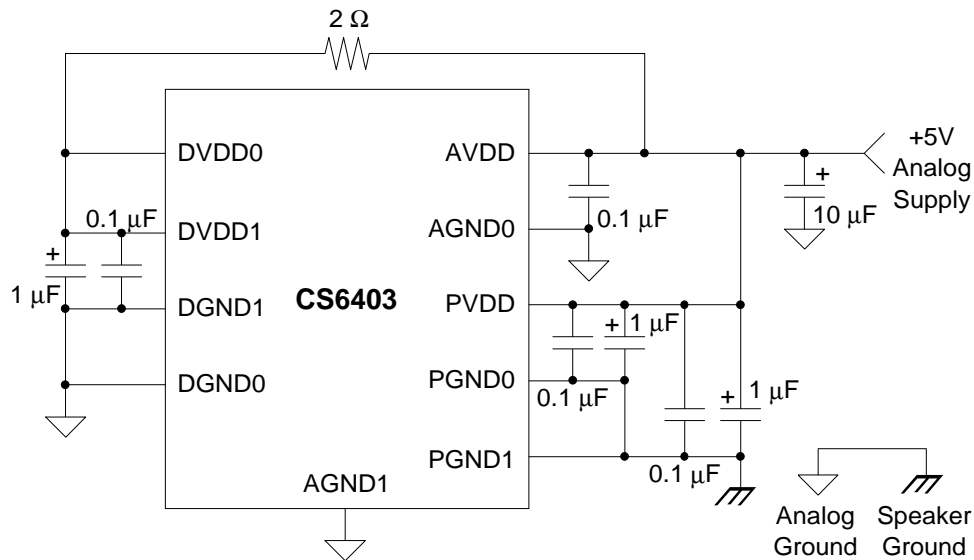

**Figure 9. Power Supply Connections**

**Detailed Power Supply Connections**

Figure 9 shows the detailed power supply connections. The CS6403 requires a clean analog quality +5V supply. The digital supply for the CS6403 should be derived through a 2Ω resistor from the clean system analog supply, and should not be connected directly to the board-level digital 5V supply.

**Grounding and Layout**

The CS6403 requires very careful attention to layout, power supplies, and decoupling to achieve rated performance. Extensive use of ground planes and ground-plane fill is recommended. The system performance is optimized when the circuit board is partitioned into a digital region and an analog region, each with its own, non-overlapping, ground plane. The CS6403 should be completely over the analog ground plane, close to the digital region. The package should be oriented so that the digital pins face toward the digital region of the board. Figure 10 shows the general guidelines for proper layout.

The power and ground connections for the speaker (PVDD and PGND) should be routed separately from the analog power and ground planes to prevent the high speaker currents from flowing in the same ground plane as the microphone signal. In applications where the speaker driver is not used no separate ground routing is required.

**Embedded Signal-Processing Functions**

As shown in Figure 3, the CS6403 provides several processing functions that are required for good full-duplex, hands-free performance.

Schematic & Layout Review Service

**Confirm Optimum Schematic & Layout Before Building Your Board.**

**For Our Free Review Service Call Applications Engineering.**



Call : ( 5 1 2 ) 4 4 5 - 7 2 2 2

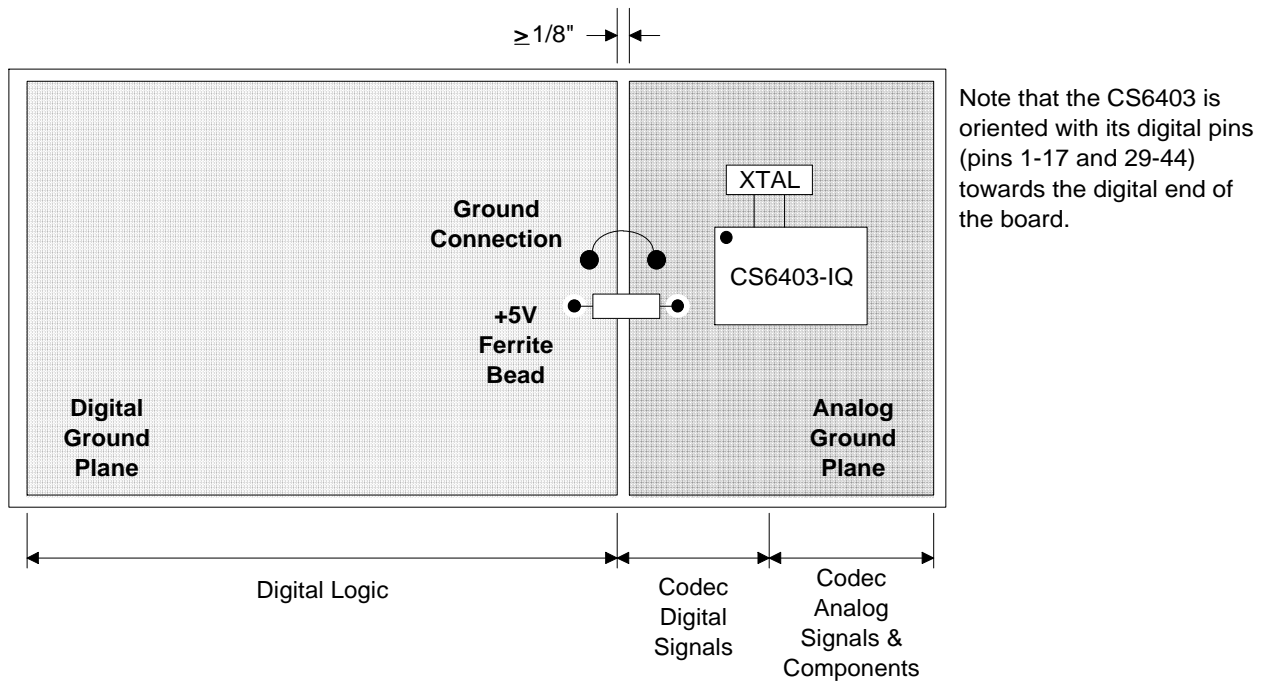

**Figure 10. Suggested Layout Guideline**

These processing blocks are described in the following sections.

**Echo Cancellers**

Echo cancellers provide two benefits to full-duplex communication systems: loop-gain reduction and echo reduction. Loop-gain reduction can prevent acoustic instability and acoustic howling in systems where closed acoustic paths are present. Echo reduction can prevent a talker from hearing his own voice reflected back. Such reflections are particularly annoying in systems where there is a large transport or coding delay in the communications paths. An echo canceller provides echo reduction by estimating the impulse response of the reflecting path, and then subtracting out the echo.

The echo cancellers in the CS6403 are designed to best cancel echo produced in linear, time-invariant paths. Nonlinearities and time variance in the paths can limit echo return-loss enhancement (ERLE) performance.

A CS6403 provides two echo cancellers: an acoustic echo canceller, and a network canceller (see Figure 3). The network canceller removes reflections due to impedance mismatches in the network. The acoustic canceller removes near end speaker signals that are coupled into the near-end microphone. In systems where there is no network echo (e.g., in some ISDN applications), the network canceller can be disabled, causing all 64 ms of echo cancellation available on the CS6403 to be allocated to acoustic echo cancellation. This is done by setting  $NECD:SSI\_CR0.8 = 1$ .

The echo cancellers on the CS6403 train continuously using the speech signals (i.e, no special training signals are generated by the CS6403 at any time) from the far end (for the acoustic canceller) and from the near end (for the network canceller). The echo cancellers' convergence performance has been optimized for speech; as a result, testing the echo-canceller performance with white noise will not give a useful indication of expected performance.

Several echo-canceller controls are provided in Mode 2 (16 bit) operation via the SSI control registers. In addition, visibility and control functions are provided through the general-purpose I/O pins (see the pin-definition section).

### ***Graded Beta***

"Graded Beta" is a performance enhancement used to improve the convergence speed and asymptotic ERLE performance of the acoustic echo canceller on the CS6403. Given a lower limit to the decay rate of the expected echo responses, the CS6403 will adjust the updates to the acoustic echo canceller to take advantage of that information.

By default, the CS6403 assumes a decay rate of at least 0.38 dB per ms. Based on experiments performed at Crystal, the acoustic echo-path decay rate for car interiors tends to be at least one dB per ms. Offices, on the other hand, tend to be more "live", with decay rate potentially below 0.38 dB per ms. Note that the minimum-expected decay rate can be set via SSI\_CR0 bits 3 and 2.

### ***Half-Duplex Suppression***

After the CS6403 is powered up or reset, 2-3 seconds of far end and near end speech must be processed by the echo cancellers to sufficiently reduce loop-gain and therefore prevent acoustic howling. To prevent howling while the echo cancellers are not properly trained, a half-duplex echo suppressor is enabled. Once the echo cancellers are properly trained, the half-duplex suppressor is automatically disabled. (Note that whether the CS6403 is operating in half or full duplex at any particular time is indicated via the GPOUT1 output pin).

This half-duplex suppressor works like the suppressor in a half-duplex speakerphone; i.e., it allows signals to pass through the CS6403 in only one direction at a time. The talker at one

end of a conversation cannot be heard at the other end until the talker at the other end is silent.

The half-duplex algorithm in the CS6403 has been designed to discriminate between noise and speech, and should provide good performance in noisy environments.

### ***Full-Duplex Suppression***

After the echo cancellers have been trained, the half-duplex suppressor is automatically disabled. This transition occurs when the ERLE performance of the echo cancellers exceeds a fixed threshold.

In some cases, due to impairments like nonlinearities, the echo cancellers may not provide sufficient ERLE. To accommodate such situations, the CS6403 provides supplementary full-duplex suppression. This full-duplex suppression technique provides additional ERLE using dynamic gain-control and accounts for the "Non-linear Echo Control" block in Figure 3.

### ***Operation in Noise***

The CS6403 echo cancellers have been designed to give good performance in noisy environments. However, for best performance, the echo cancellers should be trained in a low-noise environment. If the noise level is high during the training interval, the echo canceller may not be able to achieve enough ERLE to transition out of half duplex, regardless of how much speech is received.

If the noise level subsequently drops sufficiently while a speech training signal is present, the echo canceller can train, allowing the CS6403 to transition to full duplex. If the noise level then increases, the echo canceller will use the path-response estimate calculated while the noise level was low, allowing the echo canceller to remain in full duplex.

### Automatic Gain Control (AGC)

By default, automatic gain-control is provided in the far-end receive path (see Figure 3). This AGC provides dynamic gain changes to keep the signal strength at the near-end output the same for weak and strong far-end input signals. The AGC may be disabled either via AGCD: SSI\_CR1.10, or by setting the volume control to level 10.

### Real-time controls

The GPIN pins allow real-time control over common functions such as mute, volume control, half-duplex control, and echo canceller status. GPIN3 controls the microphone gain stage status at reset and mute after reset (see Table 4). GPIN2, GPIN1, and GPIN0 work in concert to implement volume control, half-duplex disable/enable, and filter coefficient control.

#### GPIN3

GPIN3 controls two chip functions: microphone gain stage and mute. Immediately after reset, GPIN3 is sampled and, if high, the 26dB microphone gain stage is disabled. With the microphone gain disabled, full scale input is 1 Vp. With the microphone gain enabled, full scale is 50 mVp.

1 ms after reset, a change in the state of GPIN3 will mute the transmit path (send all zeroes out SDO), and set the receive path full on. So, if GPIN3 was high at reset, setting it low will mute the microphone. Restoring the state of GPIN3 will unmute the microphone.

#### GPIN2/1/0

GPIN2/1/0 act in concert to encode eight states as described by Table 5 in the pin description section. These pins are meant to be driven by a microcontroller or other digital device to allow

GPIN3 (at reset)	GPIN3 (1ms after reset)	Action
0	0	26 dB enable, no mute
0	1	26 dB enable, mute
1	0	26 dB disable, mute
1	1	26 dB disable, no mute

**Table 4. Mute Controls.**

user control of the echo canceller. To enter a state, the user must apply the appropriate value at GPIN2/1/0 for 375µS (3 samples) before the change will take effect. For example, to increase the SPKROUT volume by one step, GPIN2/1/0 needs to be: 110. Applying 110 to GPIN2/1/0 for 375µS (or longer) will cause the volume to be raised by 3dB. To again raise the volume by 3dB, the system would have to change state away from 110 to another state for 375µS (100 is a don't care state), then switch back to 110 for at least 375µS.

#### Half-Duplex Disable (011,111)

In some applications, the half-duplex mode of the CS6403 may be unnecessary or undesirable. In these cases, the GPIN pins may be used to disable the half-duplex mode by setting GPIN2/1/0 to either 011 or 111.

#### Half-Duplex Enable (000)

This state is on by default when the CS6403 is reset. If the half- duplex mode is disabled using the 011 or 111 setting, it can be restored by setting GPIN2/1/0 to 000.

#### Clear Coefficients (001)

Clearing the coefficients of the adaptive filter effectively disables the echo canceller. This will force the CS6403 to operate in half- duplex mode unless half-duplex mode is disabled as described above. Clear Coefficients is maintained only as long as 001 is applied to the GPIN2/1/0 pins.

### ***Increase Volume (110)***

Setting GPIN2/1/0 to 110 for 375 $\mu$ S will decrement the volume increment counter by one step causing an increase in the SPKROUT volume. To increase volume again, the GPIN2/1/0 pins must be changed to another state before returning to 110. See section entitled "Volume Control/ AGC" for more details.

### ***Decrease Volume (101)***

Setting GPIN2/1/0 to 101 for 375 $\mu$ S will increment the volume increment counter by one step causing an decrease in the SPKROUT volume. To decrease volume again, the GPIN2/1/0 pins must be changed to another state before returning to 101. The section below entitled "Volume Control/AGC" explains this function in greater detail.

### ***Don't Care (010, 100)***

When the GPIN2/1/0 pins are set to 010, or 100, the CS6403 ignores the input. This state is provided in order to provide a "resting place" between consecutive volume increase or volume decrease requests.

### ***Volume Control/AGC***

The SPKROUT volume control of the CS6403 is implemented in two stages: the upper ten volume increments are implemented by a software peak-limiting automatic gain control (AGC); the lower 32 volume increments are controlled by a hardware DAC attenuation stage with software compensation at the adaptive filter to avoid changing the echo path. The volume increments range from 0 (loudest) to 41 (quietest).

The AGC works by comparing the digital codes coming from SDI to a threshold value, and if the signal amplitude is greater than the threshold, it is scaled down to the threshold. These signals

are subsequently scaled up so that the threshold is full scale. The threshold value which is roughly determined by the formula:  $\text{Threshold} = \text{Full Scale} - (10 - \text{Volume Increment}) \times 3\text{dB}$ . For example, a volume increment of 0 (the loudest output volume possible) would force signals greater than 30dB below full scale ( $10 \times 3\text{dB}$ ) to 30dB below full scale and then scale all signals up 30dB so that 30dB below full scale becomes full scale.

When the AGC is controlling the output volume, the steps are effectively 3dB per volume increment. Note that if the signals are already strong, increasing the volume may not make the sound any louder since they are already being scaled up to full scale. Also note that the AGC is effectively disabled by setting the volume increment to 10. The default volume increment (set upon reset) is 4.

When the DAC attenuation stage is controlling the output volume, the step size is 2.5dB per volume increment. The 32 steps (from volume increment 10 to 41) yield up to 77.5dB of additional attenuation.

Note that if the AGCD (SSI\_CR1.10) is set in Mode 2 (16-bit), then the DAC is attenuated by 10 dB ( $4 \times 2.5$  dB), and the effective volume control range is from volume increment 0 to 31, with each increment equal to 2.5 dB of attenuation.

The volume increment defaults to 4 upon reset. If an attempt is made to increase volume beyond volume increment 0, the GPOUT0 pin will go high for 125 $\mu$ S. GPOUT0 will also go high if an attempt is made to decrease volume beyond volume increment 41.

**PIN DESCRIPTIONS**

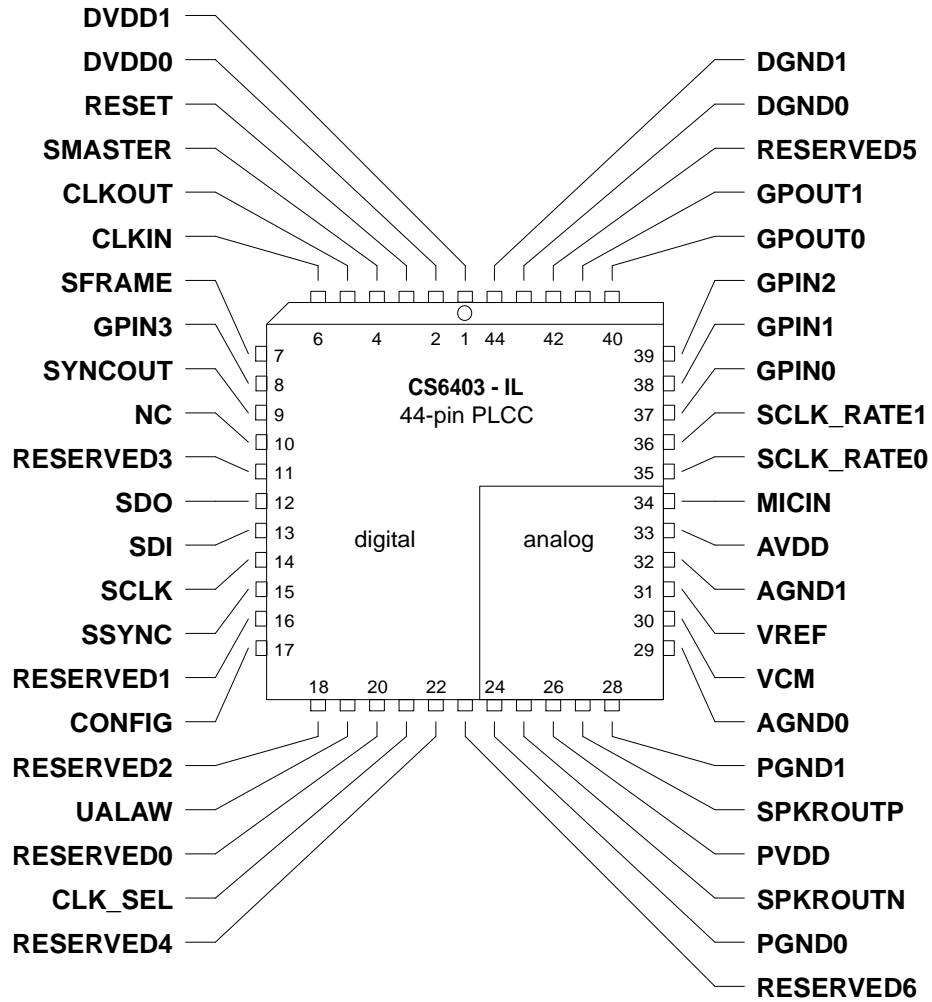

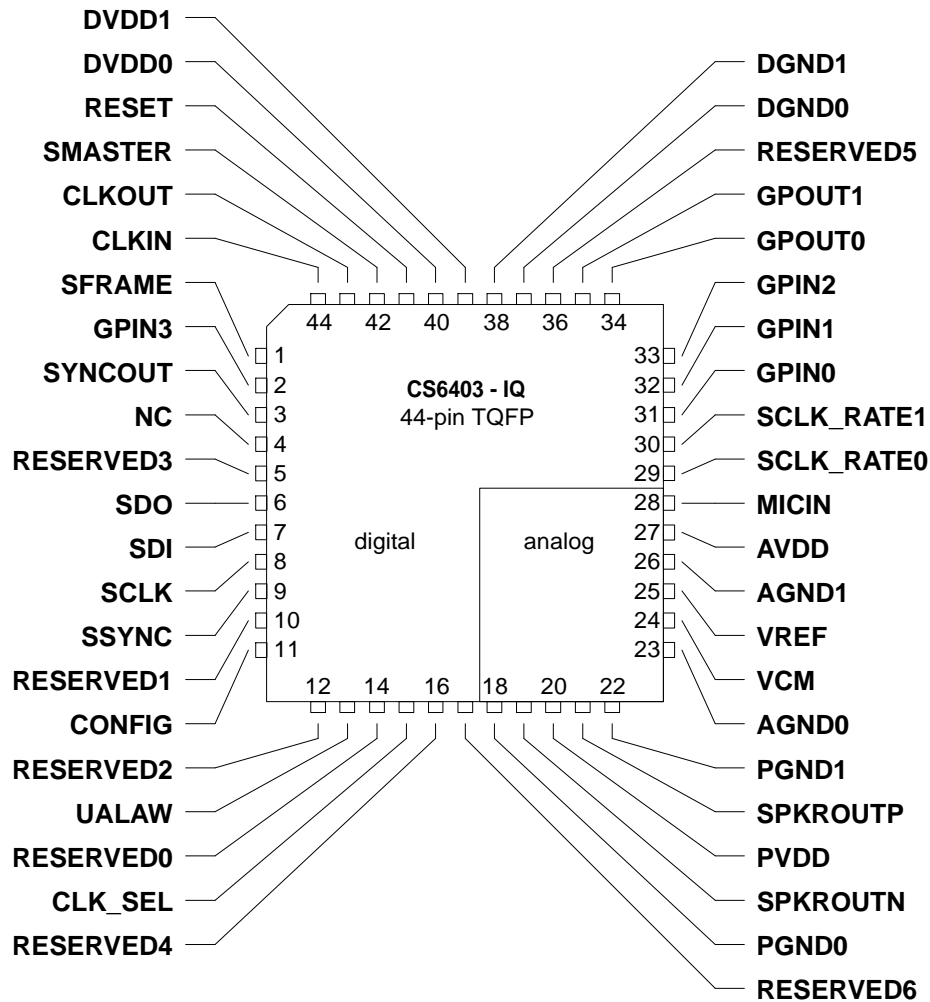

**Power Supply**

**AGND0 - Analog ground, PIN 23Q, 29L**  
Analog ground.

**AGND1 - Analog ground, PIN 26Q, 32L**  
Analog ground.

**AVDD - Analog supply, PIN 27Q, 33L**  
+5V Analog supply.

**DGND0 - Digital ground, PIN 37Q, 43L**  
Digital ground.

**DGND1 - Digital ground, PIN 38Q, 44L**  
Digital ground.

**DVDD0 - Digital supply, PIN 40Q, 2L**

Digital +5V supply.

**DVDD1 - Digital supply, PIN 39Q, 1L**

Digital +5V supply.

**PGND0 - Speaker-driver ground, PIN 18Q, 24L**

Speaker driver ground.

**PGND1 - Speaker-driver ground, PIN 22Q, 28L**

Speaker driver ground.

**PVDD - Speaker-driver supply, PIN 20Q, 26L**

Speaker-driver +5V supply.

**Analog I/O****MICIN - ADC input, PIN 28Q, 34L**

Audio analog input.

**SPKROUTN - DAC inverted output, PIN 19Q, 25L**

Negative differential speaker-driver output. The voltage on SPKROUTN will decrease if the DAC value is increased.

**SPKROUTP - DAC output, PIN 21Q, 27L**

Positive differential speaker-driver output. The voltage on SPKROUTP will increase if the DAC value is increased.

**VCM - Voltage reference common out, PIN 24Q, 30L**

No time-varying loads should be attached to VCM. Output voltage is about 1V into a load of not less than 100k $\Omega$ . Must be connected to AGND0 via a 1  $\mu$ F and a 0.1  $\mu$ F capacitors. Connections should be made with short, fat traces.

**VREF - Voltage reference bypass out, PIN 25Q, 31L**

Voltage reference used internal to the CS6403. Must be connected to AGND0 via a 1  $\mu$ F and a 0.1  $\mu$ F capacitors. Connections should be made with short, fat traces. No external loads should be connected to VREF.

**Reserved****RESERVED0 - PIN 14Q, 20L**

Must be grounded in normal operation.

**RESERVED1 - PIN 10Q, 16L**

Must be held high in normal operation.

**RESERVED2 - PIN 12Q, 18L**

Must be grounded in normal operation.

**RESERVED3 - PIN 5Q, 11L**

Must be grounded in normal operation.

**RESERVED4 - PIN 16Q, 22L**

Must be grounded in normal operation.

**RESERVED5 - PIN 36Q, 42L**

Must be grounded in normal operation.

**RESERVED6 - PIN 17Q, 23L**

Must be grounded in normal operation.

***Mode Control*****CONFIG - Configuration-control input, PIN 11Q, 17L**

CONFIG is used in conjunction with other configuration-control pins to control operating mode (see Table 2). Serial data is 16-bits long in Mode 2 if CONFIG is high, 8-bits if CONFIG is low.

**SCLK\_RATE0 - SCLK frequency control, PIN 29Q, 35L**

Used in conjunction with SCLK\_RATE1 to set the SCLK frequency when the CS6403 is a timing slave. Possible frequencies are 2.048 MHz, 1.024 MHz, and 256 kHz, for SCLK\_RATE1:SCLK\_RATE0 being 11, 10, and 00, respectively. However, if the CS6403 is a timing master (i.e., SMASTER is high), the SCLK frequency may only be 2.048 MHz, so in this case, SCLK\_RATE0 must be high.

**SCLK\_RATE1 - SCLK frequency control, PIN 30Q, 36L**

Used in conjunction with SCLK\_RATE0 to set the SCLK frequency when the CS6403 is a timing slave. Possible frequencies are 2.048 MHz, 1.024 MHz, and 256 kHz, for SCLK\_RATE1:SCLK\_RATE0 being 11, 10, and 00, respectively. However, if the CS6403 is a timing master (i.e., SMASTER is high), the SCLK frequency may only be 2.048 MHz, so in this case, SCLK\_RATE1 must be high.

**SFRAME - SSYNC frame/pulse control, PIN 1Q, 7L**

If SFRAME is high, SYNCOUT is high during serial data transactions. If SFRAME is low, SYNCOUT is pulsed high for one SCLK period before the start of a serial-data transaction.

**SMMASTER - SCLK direction control, PIN 42Q, 4L**

SMMASTER is used in conjunction with other configuration-control pins to control operating mode (see Tables 1 and 2). If SMMASTER is high, the CS6403 is a timing master, meaning that SCLK is an output, and the SCLK rate is set by the on-board crystal oscillator (nominally 2.048 MHz for an 8.192 MHz crystal). If SMMASTER is low, the CS6403 is a timing slave, meaning that SCLK is an input, and the SCLK rate is set by the external DSP, but SCLK\_RATE0 and SCLK\_RATE1 must be set to reflect the nominal SCLK rate.

**UALAW - PIN 13Q, 19L**

When UALAW is high, 8-bit serial data is  $\mu$ -law; when UALAW is low, 8-bit serial data is A-law.

***Serial Digital I/O*****SCLK - Serial clock, PIN 8Q, 14L**

SCLK is the bit clock for the serial interface. It may be an output operating at 2.048 MHz or an input operating at 256 kHz, 1.024 MHz, or 2.048 MHz depending on the states of SCLK\_RATE0, SCLK\_RATE1 and SMMASTER.

**SDI - Serial data in, PIN 7Q, 13L**

SDI is the serial-data input to the CS6403.

**SDO - Serial data out, PIN 6Q, 12L**

SDO is the serial-data output from the CS6403.

**SSYNC - Input synchronization signal for serial port, PIN 9Q, 15L**

SSYNC is the serial-data synchronization strobe used when the CS6403 is a system-timing slave. Should be grounded in master mode (SMMASTER = 1).

**SYNCOUT - Output synchronization signal for serial port, PIN 3Q, 9L**

SYNCOUT is the serial-data synchronization strobe used when the CS6403 is a system-timing master. Timing and duration depends on SFRAME.

***Miscellaneous*****CLK\_SEL - PIN 15Q, 21L**

Disable the on-chip phase-locked loop when high.

**CLKIN - System input clock from external master, PIN 44Q, 6L**

If the CS6403 is a system-timing master, a 8.192 MHz clock-crystal circuit is connected between CLKIN and CLKOUT. If the CS6403 is a system-timing slave, CLKIN must be grounded.

**CLKOUT - System output clock, PIN 43Q, 5L**

If the CS6403 is a system-timing master, a 8.192 MHz clock-crystal circuit is connected between CLKIN and CLKOUT. Otherwise, CLKOUT is unconnected.

**GPIN0 - General-purpose input, PIN 31Q, 37L**

Refer to Table 5 below.

**GPIN1 - General-purpose input, PIN 32Q, 38L**

Refer to Table 5 below.

**GPIN2 - General-purpose input, PIN 33Q, 39L**

Refer to Table 5 below.

**GPIN3 - General-purpose input, PIN 2Q, 8L**

Disables 26dB microphone gain when high at reset. Controls Mute after reset. See Table 4 for more details.

**GPOUT0 - General-purpose outputs, PIN 34Q, 40L**

GPOUT0 is high when a volume change request is made that exceeds the available range.

**GPOUT1 - General-purpose outputs, PIN 35Q, 41L**

GPOUT1 is high while the CS6403 is in half-duplex mode during initial convergence.

**RESET - System reset, PIN 41Q, 3L**

RESET must be asserted high for at least two SCLK periods after powerup to place the CS6403 in a known state.

**NC - No Connect, PIN 4Q, 10L**

NC must be left floating in normal operation.

GPIN2	GPIN1	GPIN0	
0	0	0	Move to HD-enable state
0	0	1	Clear coefficients (not debounced)
0	1	0	Don't care
0	1	1	Move to HD-disable state
1	0	0	Don't care
1	0	1	Decrease volume one step
1	1	0	Increase volume one step
1	1	1	Move to HD-disable state

**Table 5. Algorithmic Controls.**

---

**PARAMETER DEFINITION****Anti-Alias Rejection**

The rejection of input frequencies in the frequency range  $>F_s/2$  of all multiples of the input sample rate ( $64 \times F_s$ ). This rejection is almost solely dependent on the external input RC.

**Audible (<20kHz) Noise**

The DAC audible noise floor. Measured by applying a -60dB, 1kHz sine wave.  $S/(N+D)$  is then measured (over a  $F_s/2$  to 20kHz bandwidth). Then add 60dB to the answer, to compensate for the -60dB signal level.

**Convergence**

The process by which an echo canceller improves its path estimate, thereby improving its echo return-loss enhancement. Convergence is complete once the echo return-loss enhancement reaches its best value for a given environment.

**Differential Nonlinearity**

The worst case deviation from the ideal codewidth. Units in LSB.

**ERLE**

Echo signal-power reduction (Echo Return-Loss Enhancement) provided by an echo canceller. Maximum ERLE for an echo canceller is dependent on training-signal statistics and echo-path attributes. Units in dB.

**Frequency Response**

Worst case variation in output signal level versus frequency over the passband (20Hz to  $0.45F_s$ ), referenced to the level at 1kHz. Units in dB.

**Instantaneous Dynamic Range**

IDR is the ratio of a full-scale rms signal to the rms noise available at any instant in time, without changing the input gain or output attenuation settings. It is measured using  $S/(N+D)$  with a 1 kHz, -60 dB input signal, with 60 dB added to compensate for the small input signal. Use of a small input signal reduces the harmonic distortion components to insignificance when compared to the noise. Units in dB.

**Integrated Inaudible (>20kHz) Energy**

The integrated signal level on the analog output pin after a 20kHz hi-pass filter. Zero digital input into the DAC. Units in mVrms.

**Offset Error**

For the ADC, the deviation of the output code from the mid-scale with the selected input at VCM. For the DAC, the deviation of the output from VCM with mid-scale input code. Units in LSB's for the ADC and millivolts for the DAC.

**Resolution**

The number of bits in the input words to the DAC, and in the output words from the ADC.

**Total Dynamic Range**

TDR is the ratio of the rms value of a full scale signal to the lowest obtainable noise floor. It is measured by comparing a full scale signal to the lowest noise floor possible in the codec (i.e., attenuation bits for the DAC at full attenuation). Units in dB.

**Total Harmonic Distortion**

THD is the ratio of the rms amplitude of the test signal to the rms sum of all the harmonic components. 1 kHz is used for testing. Units in dB.

• **Notes** •

**Evaluation Board for CS6403**

**Features**

- Easy access to CS6403 SSI
- Phantom power for microphone
- Easy access to algorithm controls
- Includes far-end codec for stand-alone operation
- Analog and Digital Patch Area

**Description**

The CDB6403 allows an end-user to quickly integrate the CS6403 Echo Cancelling Codec into a system and evaluate its performance. The board provides everything needed to enable flexible setup and evaluation. Evaluation requires only a +5 V power supply for standalone mode testing. Connections for analog audio sources are provided on the board.

**ORDERING INFORMATION**

CDB6403

Evaluation Board

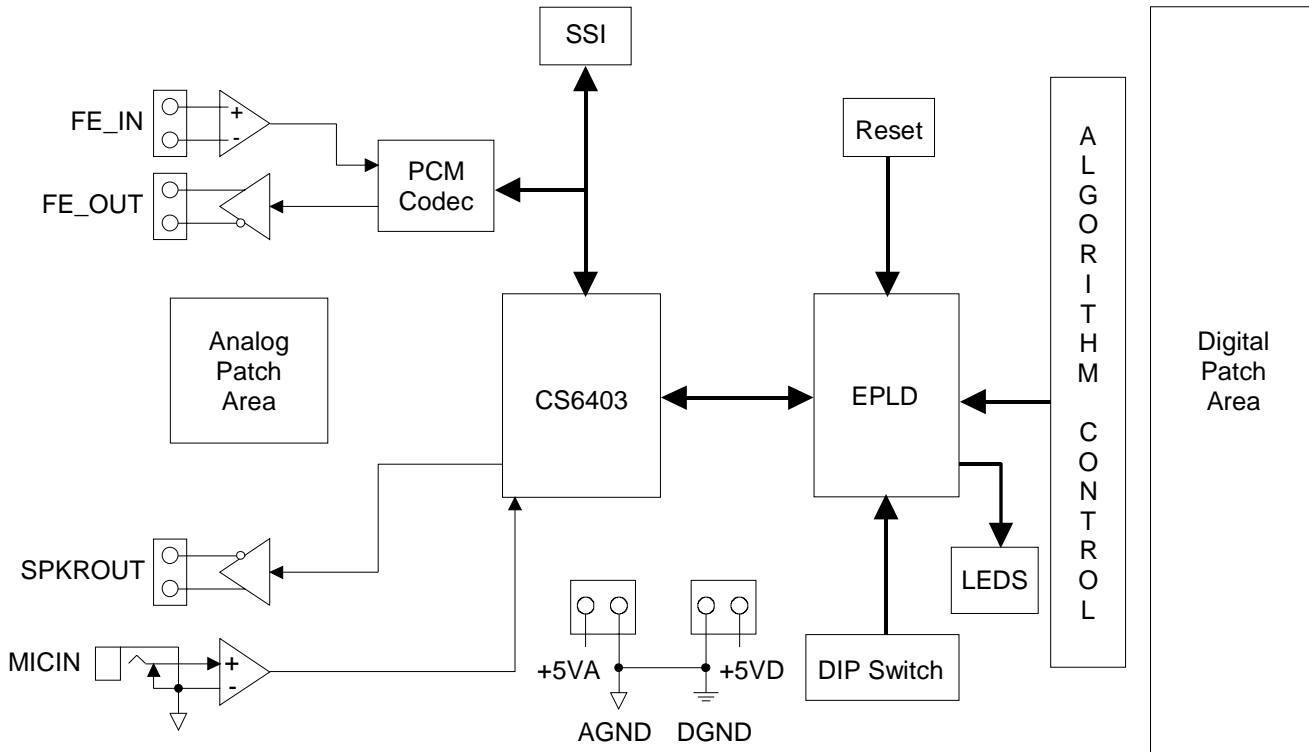



Another important note about the differential amplifier is that it is biased to swing around 1VDC. This is fine when the CS6403 gain stage is on, as full scale into the part is 100mVpp. When the gain stage is off, however, the full scale input is 2Vpp, which forces the op-amp to swing from 2V to 0V. Since the op-amp won't drive this close to the negative rail, it is advisable to change the bias point to about 2VDC. This can be easily achieved by connecting pin 7 of the op-amp to the right side of R104, cutting the trace above and below the right-hand pad of R104, and strapping VCM to pin 5 of the op-amp.

**Far-End Analog Interface**

In Mode 1 the far-end signals are provided to the CS6403 via the MC145480 PCM codec by default. The analog signals provided to the MC145480 are shown in Figure 3. The FE\_IN terminal block provides a differential input for the far-end input. The fullscale voltage for this input is 1.575Vp referenced to 2.4V in its current unity gain configuration (see PCM Codec below).

The FE\_OUT terminal block provides the far-end output either differentially or single-ended depending on whether J8 or J10 is shorted. The output level of each individual output is 1.575Vp referenced about 2.4V. The FE\_OUT is capable of driving a 2kΩ load.

Signal polarity is indicated by "+" and "-" symbols silkscreened near the connectors. These connectors are not used in Mode 2.

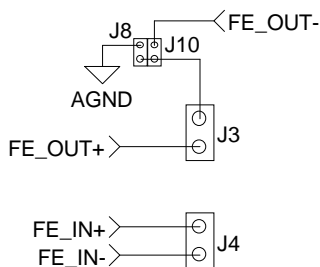

**Figure 3. Far-End Input and Output Analog Connections**

**CS6403**

The CS6403 Echo Cancelling Codec, shown in Figure 4, is the heart of the evaluation board. See the CS6403 datasheet for full details on this part.

The evaluation board is a good example of proper layout and grounding of the CS6403. Note that the part resides completely on the analog ground plane and that all the power supplies are decoupled with a 0.1μF and 1μF capacitor with the smaller capacitor closest to the chip. VCM are also well bypassed and test points exist to monitor these values.

A test point labeled MICIN allows the evaluator to monitor the signal at the MICIN pin of the CS6403. This signal should be a maximum of 2Vpp with the internal gain stage off (GPIN3 high), and 100mVpp with the internal gain stage on (GPIN3 low).

SPKROUTP and SPKROUTN also have test points on either side of the screw terminal. J14 and J15 are provided so that intermediate circuitry can intercept and process the SPKROUT signals, if desired. Note that SPKROUTP and SPKROUTN each drive a maximum of 1.75Vpp into an 8Ω load. Since they are 180 degrees out of phase, this can be applied differentially to produce 3.5Vpp. Do not ground either SPKROUTP or SPKROUTN as this may damage the speaker driver internally.

An 8.192MHz crystal is provided for Mode 1 applications. If the CS6403 is configured to operate in Mode 2, the crystal should be removed to prevent possible noise from interfering clocks. The crystal is socketed to facilitate removal.

## PCM Codec

The MC145480 codec is a +5V only PCM codec with filter. It can be used in either  $\mu$ -law or A-law companding modes depending on the state of the UALAW DIP switch. It is included to provide a far-end analog interface for Mode 1 applications.

When Mode 2 is selected for the CS6403 by setting the CONFIG DIP switch to OFF, the MC145480 is powered down with its serial port outputs put into a high-impedance state. This behavior eliminates the need to cut traces to prevent signal contention.

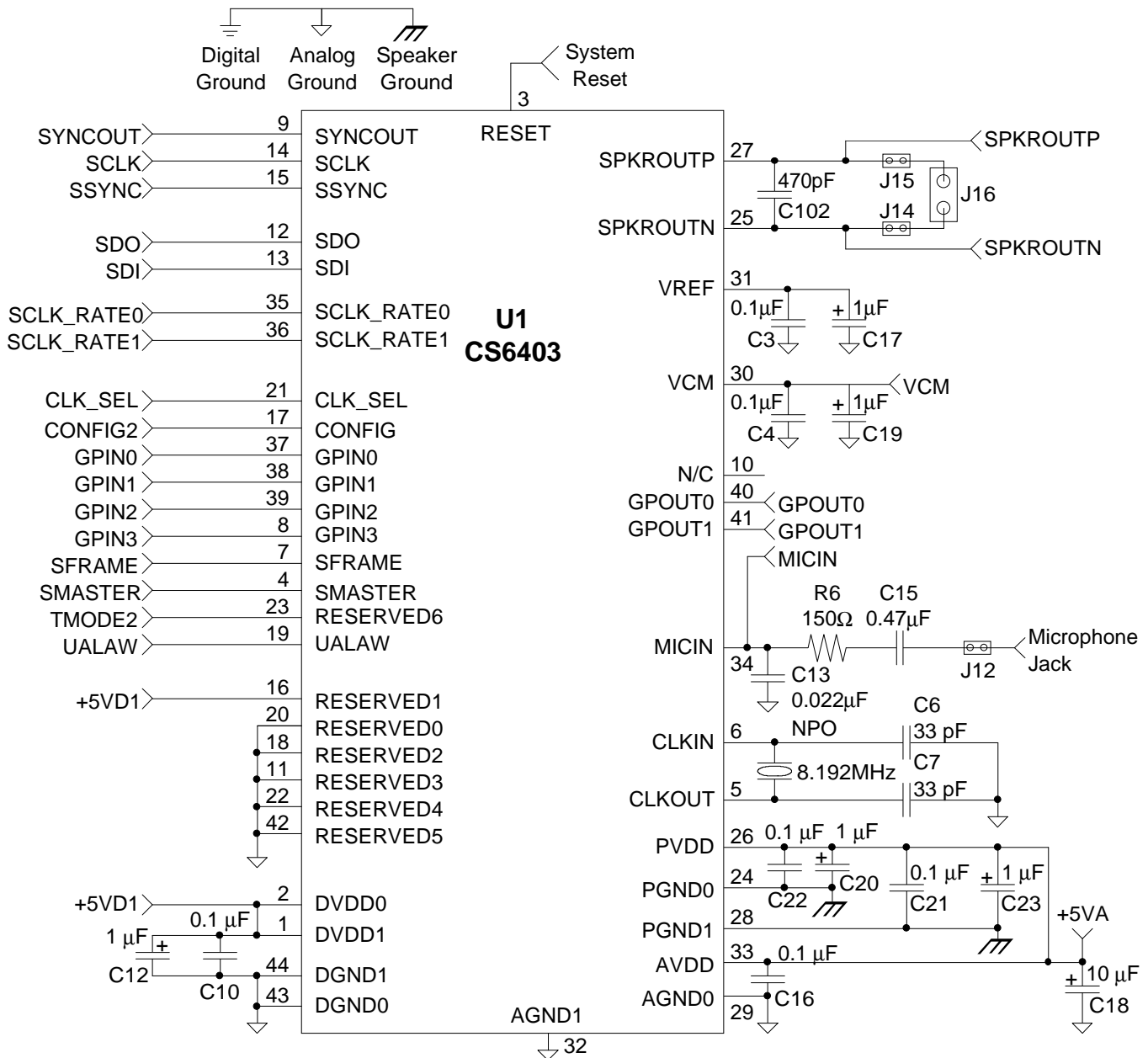
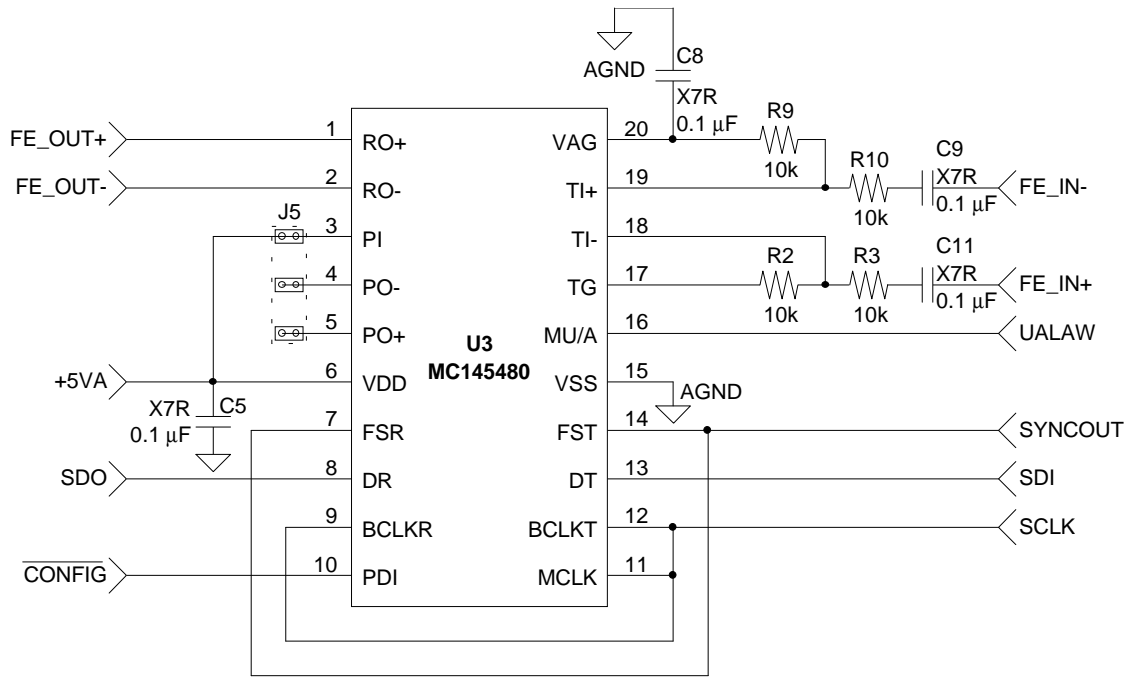

Figure 4. CS6403 and Associated Circuitry



**Figure 5. On-board PCM Codec**

The far-end input gain is determined by R2, R3, R9, and R10 which are all currently 10kΩ. The resistors are part of a differential amplifier whose gain is  $(-R2/R3)$ . Note that R2 and R9 should have the same value, as should R3 and R10. Both FE\_IN+ and FE\_IN- are connected through a 0.1µF DC blocking capacitor.

The far-end output drive capability can be boosted by using the PI, PO+ and PO- pins of the MC145480. PI and PO- are equivalent to the inverting input and output, respectively, of an opamp. PO+ and PO- are differential drivers capable of driving a 150Ω load. Easy access to PI, PO-, and PO+ is provided through J5, J6, and J7, respectively. See the MC145480 datasheet and Figure 5 for more details.

**EPLD**

The EMP7032 EPLD from Altera handles some miscellaneous logic functions on the evaluation board, but is not necessary for operation. It is mainly used to encode the Algorithm Control Switches (SW2-6) to the GPIN2/1/0 pins. It also buffers the DIP switches, and it provides inverters for the LED bank.

The encoding of SW2-6 could have been done without using programmable logic, but the EPLD assures that only legal combinations of buttons are accepted for all modes of operation of the evaluation board. The EPLD provides the function of several buffers, inverters, and AND/OR gates. A Schmitt-trigger inverter U101 is added to provide hardware debouncing of the switches.

An added benefit of the EPLD is that it demonstrates effective use of separate ground planes for analog and digital components. Although all of the digital logic in the EPLD is relatively static, the CDB6403 provides a good example of how to split the digital and analog sides of a board. Note that the CS6403 resides completely on the analog side of the board and digital signals cross the break in the ground planes by taking the shortest possible route.

**SSI**

Mode 2 of the CS6403 requires that the far-end input and output are provided to the CS6403 digitally via the Synchronous Serial Interface (SSI). The ten pin dual-row stake header J1 presents these signals for easy access to a DSP serial port. See Figure 6 for pinout.

These signals are still available in Mode 1, however, SDI will be driven by the MC145480 and care should be taken to avoid contention on this pin if anything is connected to the SSI.

**Reset**

The Reset button is used to reset the CS6403 to a known state. The reset circuitry is intended to perform a power-on reset function. The Schmitt-trigger inverter corrects the sense of the RESET signal for the CS6403 and debounces the switch. Figure 7 shows the Reset circuit, as well as, the EPLD and connected switches.

**Algorithm Control**

A bank of switches near the digital patch area allows the user some control of the behavior of the algorithms running on the CS6403. SW6 is labelled NORMAL and CLEAR and controls the state of the coefficients in the echo canceller's adaptive filter. SW2-5 are momentary contact pushbutton switches which provide volume control and control of the half-duplex mode of the CS6403.

In NORMAL mode the signal injected at FE\_IN will come out SPKROUT, be picked up by MICIN, and transmitted to FE\_OUT. The signal at FE\_OUT should be echo cancelled, that is, the signal coupling at the near-end is substantially attenuated at the far-end output. It will take a few seconds of far-end speech, with the near-end being quiet to converge the echo canceller. Until then, a half-duplex mode is in place to prevent howling and to hide the echoes present before the echo canceller is converged.

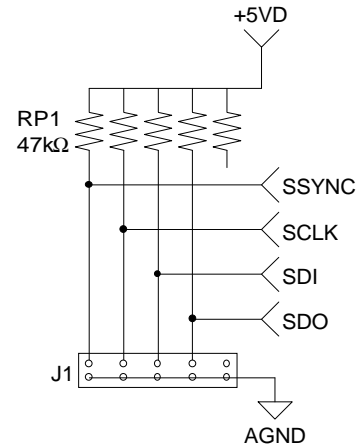

**Figure 6. Synchronous Serial Interface (SSI) Stake Header**

If SW6 is moved to the CLEAR position, the coefficients in the adaptive filter will be cleared, effectively disabling the echo canceller. Note that if the half-duplex mode is enabled (it is by default), the CS6403 will be held in half-duplex mode. If half-duplex is disabled, the signal at FE\_OUT will be whatever is received at MICIN. In order to disable the half-duplex mode, the user need only push the HD OFF pushbutton (SW5).

The four control buttons are momentary contact buttons which change the state of operation of the echo-canceller. The "HD ON" button enables the half-duplex fallback mode of the echo canceller. The "HD OFF" button disables the half-duplex mode. Note that if the echo-canceller cannot provide enough echo suppression, howling may occur with the half-duplex mode disabled. "VOL UP" and "VOL DOWN" control the output volume of the SPKROUT pins. Pressing "VOL UP" will increase the volume by one step and pressing "VOL DOWN" will decrease it. Volume may be raised to a level of 0 and down to 41. GPOUT0 will go high for 125µs (visible as a flash) if an attempt is made to go out of the volume range.

The reset state of the CS6403 is half-duplex mode enabled and volume level of 4.



### DIP Switches

The DIP switch SW7 provides access to mode setting pins on the CS6403. The default settings indicate how it is shipped from the factory (Mode 1).

When a switch is in the ON position, a logic low is applied to the corresponding pin on the CS6403. Conversely, the OFF position corresponds to logic high.

Pin Name	ON Definition	OFF Definition	Default
SFRAME	Pulse-type SYNC	Frame-type SYNC	ON
SMASTER	SCLK is an input	SCLK is an output	OFF
SCLK_RATE1	see note		OFF
SCLK_RATE0	see note		OFF
CONFIG	Mode 1	Mode 2	ON
UALAW	A-law companding	$\mu$ -law companding	OFF
GPIN3	26dB Mic gain on	26dB Mic gain off	ON
CLK_SEL	PLL active	PLL bypassed (use CLKIN)	ON

Note: SCLK\_RATE1 and SCLK\_RATE0 determine the frequency of SCLK the part should expect in Mode 1. In Mode 2, both of these switches should be OFF. Mode 1 SCLK frequency is given by the following table:

SCLK_RATE1	SCLK_RATE0	SCLK Frequency
ON	ON	256kHz
ON	OFF	Invalid
OFF	ON	1.024MHz
OFF	OFF	2.048MHz

### Using the CDB6403 Evaluation Board

#### General Setup

The CDB6403 requires only a +5V power supply capable of sourcing 200mA of current in order to work. It is important to power both the analog and digital sections. Separate power supplies would be ideal, however, separate leads from the same power supply is acceptable. Once power is applied, press the RESET button to ensure the board is in a known state.

#### Definitions

We define the near-end as the end where the primary echo exists. Signal comes out of the near-end output and is picked up by the near-end input. For speakerphone applications, the near-end would be the acoustic path between the microphone and speaker. For network echo cancellers, the near-end would consist of the lossy hybrid. The near-end input of the CS6403 is the MICIN pin and the near-end output is the SPKROUT pins. The near-end input is sometimes referred to as the transmit input (TXI) and the near-end output is similarly sometimes called the receive output (RXO).

We define the far-end as the end where either no echo or secondary echo exists. Signal presented to the far-end input comes out the near-end output. Echo cancelled near-end input signal comes out the far-end output. For speakerphone applications, the far-end would be the network side of the phone. The CS6403 far-end interface is digital (via the SSI). For Mode 1 applications, a PCM codec is provided as an analog interface with FE\_IN as the far-end input and FE\_OUT as the far-end output. Mode 2 applications connect directly to the SSI of the CDB6403. Receive input (RXI) and transmit output (TXO) are other names commonly used to refer to far-end input and far-end output, respectively.

### GPIN3

By default, the CS6403 runs with an internal 26dB gain stage on MICIN. This feature is not desirable in some applications and so GPIN3 is provided to disable this feature. If the application you wish to implement needs the additional 26dB MICIN gain, set GPIN3 to ground, otherwise set it high.

The 26dB disable/enable status is read only at reset. If the state of GPIN3 is toggled anytime after reset, the CS6403 MICIN will be muted.

### Mode 1 Setup

To configure the CDB6403 for Mode 1 operation, the DIP switches should be set as follows (\* indicates a non-mode specific option):

Switch	State	Details
SFRAME	ON*	Pulse-type SYNC (frame-type should work, also)
SMASTER	OFF	CS6403 must source SCLK
SCLK_RATE1	OFF	Mode 1 requires 2.048MHz SCLK to be generated
SCLK_RATE0	OFF	Mode 1 requires 2.048MHz SCLK to be generated
CONFIG	ON	Select Mode 1
UALAW	OFF*	Select $\mu$ -law companding (A-law should work, also)
GPIN3	ON*	Enable MIC gain (may not be necessary)
CLK_SEL	ON	Enable on-chip PLL

Connect the far-end signals to FE\_IN and FE\_OUT, and the near-end signals to MICIN and SPKROUT.

### Mode 2 Setup

To configure the CDB6403 for Mode 2 operation, the DIP switches should be set as follows (\* indicates a non-mode specific option):

Switch	State	Details
SFRAME	ON	Pulse-type SYNC
SMASTER	ON	CS6403 must slave to SCLK
SCLK_RATE1	OFF*	Varies based on SCLK presented to SSI
SCLK_RATE0	OFF*	Varies based on SCLK presented to SSI
CONFIG	OFF	Select Mode 2
UALAW	OFF*	Since data is linear in Mode 2, this does not apply
GPIN3	ON*	Enable MIC gain (may not be necessary)
CLK_SEL	ON	Enable on-chip PLL

Connect the near-end signals to MICIN and SPKROUT. The far-end signals should be provided through the SSI. A DSP serial port is ideal for this.

### Setting the CDB6403 up to interface to line-level signals

Much audio equipment is designed to expect line-level signals. These signals are a maximum of 2Vrms or approximately 5.6Vpp. The CDB6403 is not configured to handle signals of this amplitude by default, but can be easily modified to accommodate it.

To configure the far-end input, FE\_IN, to accommodate 5.6Vpp, we have to scale down the signal to 3.15Vpp (full scale input of the MC145480). This is easily accomplished by merely changing R2 and R9 to 5.6k $\Omega$ , which will change the gain of the differential amplifier at the input to the MC145480 to 0.56 (3.15/5.6).

FE\_OUT is capable of producing 6.3Vpp differentially or 3.15Vpp single-ended. If the equipment intended to interface to FE\_OUT is capable of accepting a differential input, a resistive divider which attenuates the differential signal by a factor of 0.89 will be sufficient. If the equipment requires a ground reference, an external amplifier providing a gain of 1.78 to the single-ended signal is necessary.

The full-scale input at MICIN is 2Vpp with the gain stage off (GPIN3 is high). The gain of the differential amplifier provided by U100 needs to be decreased to 0.36 times. Replacing R104 and R105 with 3.6kΩ resistors and changing C101 to 0.74μF (0.68μF in parallel with 0.068μF) will change the gain appropriately while maintaining good common-mode rejection at all frequencies. It is important to make sure that the opamp is referenced around >2VDC rather than VCM, as clipping is likely to occur otherwise. This change is described in the section explaining the Microphone Circuitry.

SPKROUT drives 1.75Vpp with respect to ground out of both SPKROUTP and SPKROUTN. Even taken differentially, the resulting 3.5Vpp is not enough to reach the required 5.6Vpp. An external amplifier providing 3.2 times gain to SPKROUTP is required to produce the required output signal level.

### Troubleshooting Tips

If the CDB6403 is not working properly or is not working as expected, this list of common setup problems may help.

#### General hints:

- Make sure 5VDC is applied to both the digital and analog supplies.
- RESET the evaluation board after powerup.
- The MICIN jack is self-shorting. Make sure there is either something in the jack or that the traces to the capacitors have been cut.

- When the 26dB gain stage is not in use, the differential amplifier provided by U100 should be referenced around >2V, not VCM.
- Signal applied at FE\_IN will come out of SPKROUT. Signal applied at MICIN will come out of FE\_OUT.
- The signal applied at FE\_IN should only be picked up by MICIN from SPKROUT.
- Constant power signals (such as fixed amplitude sine waves) will attenuate after several seconds as the noise estimators determine this signal to be noise.

#### Mode 1 hints:

- If the GPOUT1 LED is not lit after RESET, the board is not operating properly. Make sure the crystal is in the socket and make sure it is oscillating. SCLK should be 2.048MHz.
- Make sure CONFIG is ON. Otherwise the MC145480 is powered down.
- The default operation of the CS6403 will force half-duplex mode upon powerup. Several seconds of speech in both transmit and receive directions will be necessary for full-duplex operation.

#### Mode 2 hints:

- Make sure CONFIG is OFF. This powers down the MC145480 and avoids contention on SDI.
- Make sure SCLK and SSYNC are being received.

## Performance Measurements

### ERLE

Echo Return-Loss Enhancement (ERLE) is defined as the amount of attenuation in echo that the echo canceller provides, usually expressed in decibels. In general, half-duplex should be disabled for ERLE measurement.

For best case performance, a sine wave is an ideal far-end input signal. Provide a -6dBFS sine wave at 1kHz to the far-end input (the SSI in Mode 2 or the far-end codec in Mode 1). It should come out the SPKROUT and couple to MICIN. The signal at MICIN will then be present at the far-end output. Measure this with coefficients cleared (RMS voltage is suggested). Measure again after the echo canceller has adapted (coefficients in normal mode). The difference between the decibel value of the two is the ERLE in dB.

To test with real speech, use an easily repeatable speech sample. Capture the non-cancelled speech with a Digital Storage Oscilloscope that can calculate RMS voltage. Do the same for the cancelled speech. There should be a delay of about five seconds of far-end speech before making the measurement to ensure that the echo canceller has time to adapt.

### Convergence Time

Convergence is loosely defined to be the state at which the echo canceller has adapted sufficiently to render the echo inaudible. Therefore, convergence time may be defined as the time required for convergence from cleared coefficients.

Convergence time may be measured using the Digital Storage Oscilloscope approach mentioned above. Once a level of attenuation which defines convergence has been chosen, a comparison of the pre-canceller and post-canceller voltage levels should indicate when convergence occurs.

## Half-Duplex

The half-duplex mode of the echo canceller is provided as a fail-safe mechanism to ensure communication in situations where the echo canceller is not providing enough ERLE for good quality conversation. To freeze the CDB6403 in half-duplex mode, push the "HD ON" switch and move the switch to the "CLEAR" position.

### Schematic & Layout Review Service

**Confirm Optimum  
Schematic & Layout  
Before Building Your Board.**

**For Our Free Review Service  
Call Applications Engineering.**



**Call : ( 5 1 2 ) 4 4 5 - 7 2 2 2**

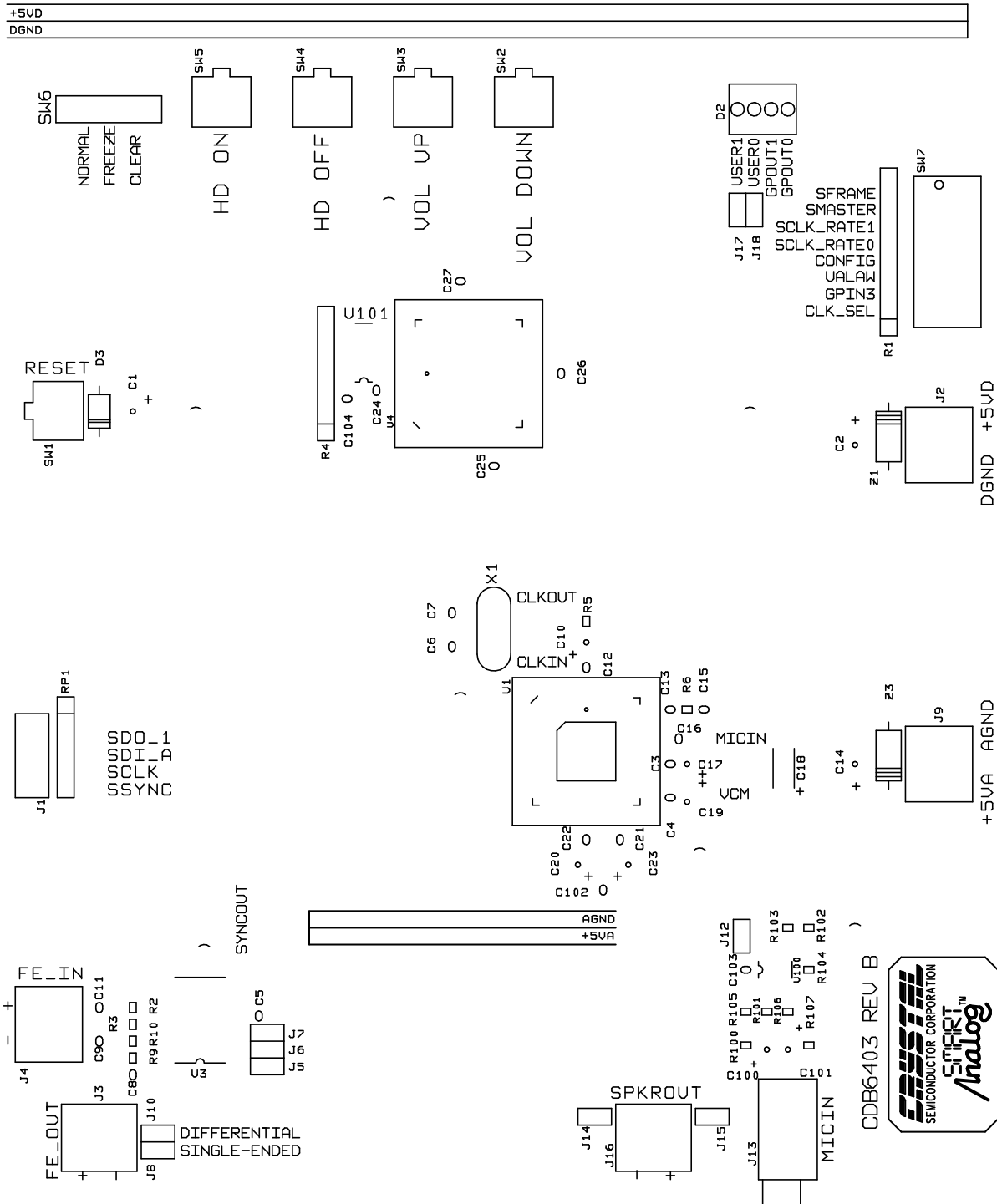

Figure 8. CDB6403 Silk Screen

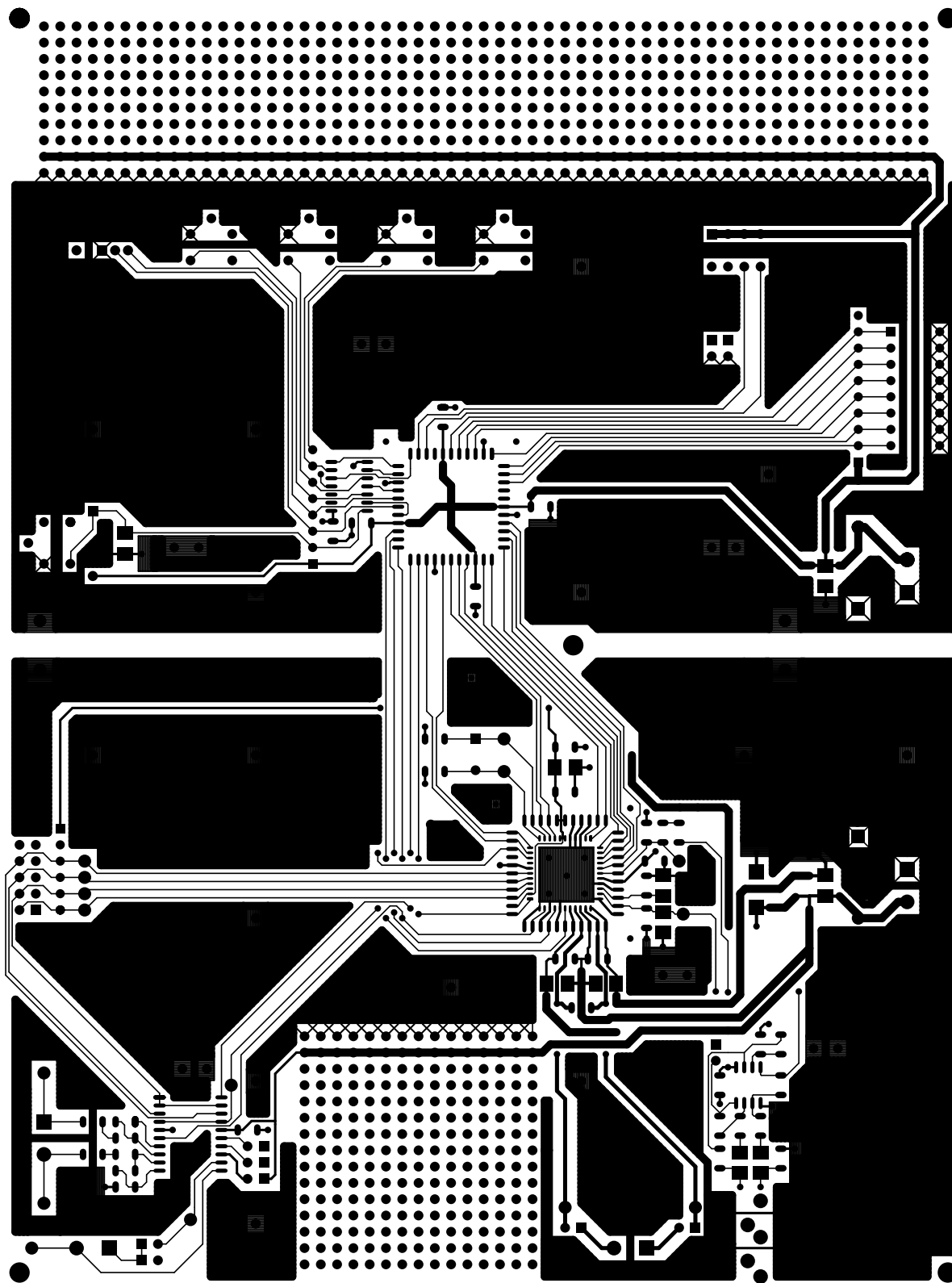

Figure 9. CDB6403 Component Side

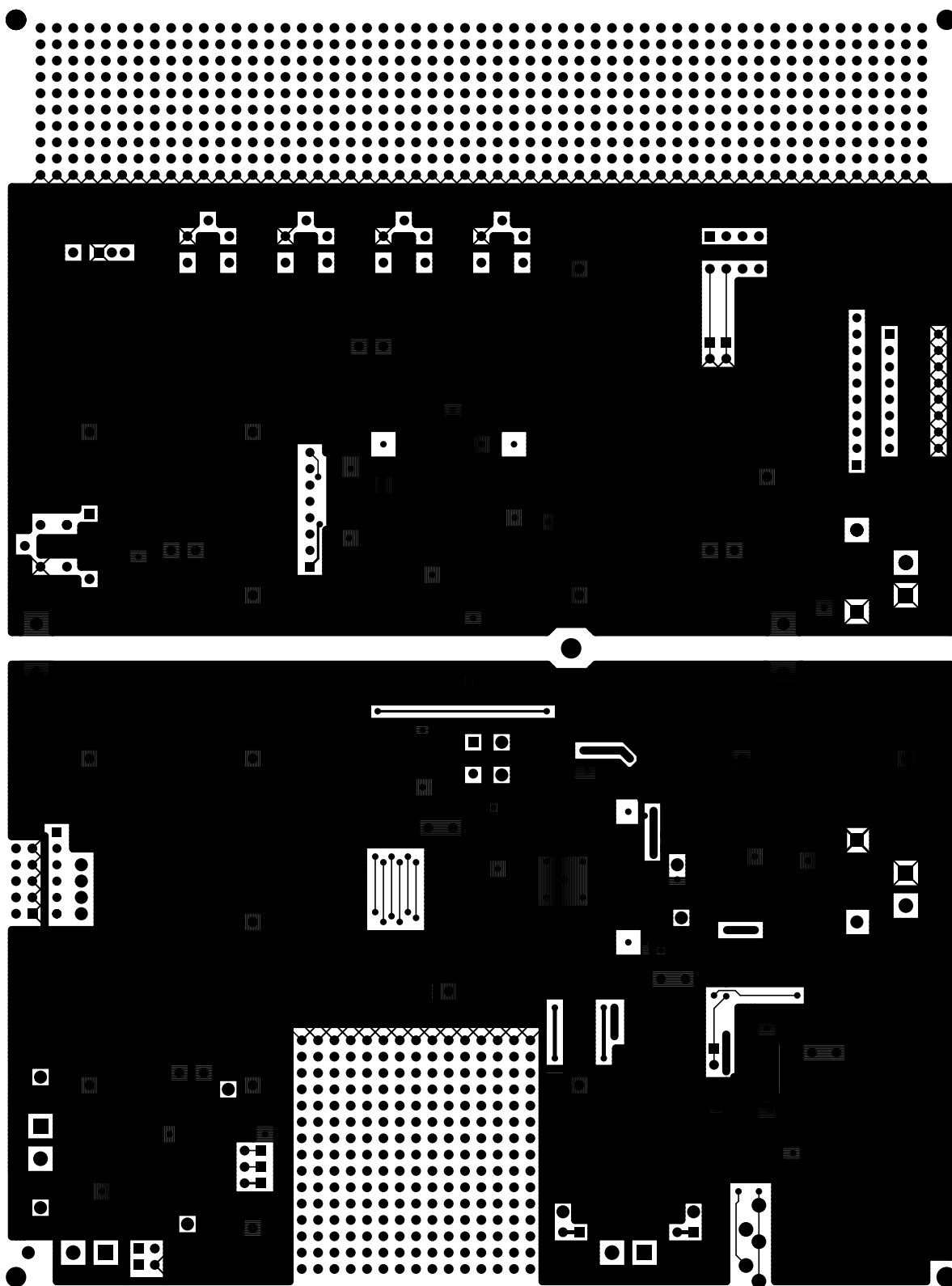
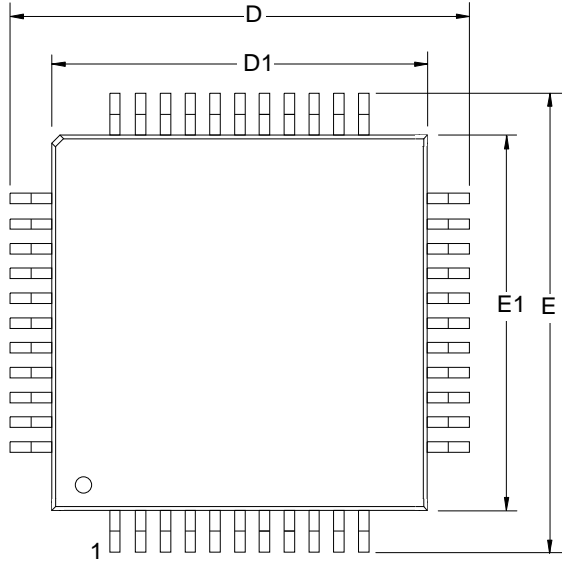
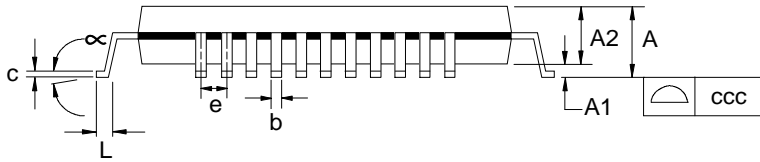

Figure 10. CDB6403 Solder Side

## 44 PIN TQFP



DIM	MILLIMETERS			INCHES		
	MIN	NOM	MAX	MIN	NOM	MAX
<b>A</b>			1.60			0.063
<b>A1</b>	0.05		0.15	0.002		0.006
<b>A2</b>	1.35	1.40	1.45	0.053	0.055	0.057
<b>b</b>	0.30	0.37	0.45	0.014	0.016	0.018
<b>c</b>	0.09	0.145	0.20	0.004	0.006	0.008
<b>D/E</b>	11.75	12.0	12.25	0.462	0.472	0.482
<b>D1/E1</b>	9.90	10.0	10.10	0.390	0.394	0.398
<b>e</b>	0.70	0.80	0.90	0.026	0.031	0.036
<b>L</b>	0.45	0.60	0.75	0.018	0.024	0.030
$\infty$	0°	3.5°	7°	0°	3.5°	7°
ccc			0.10			0.004



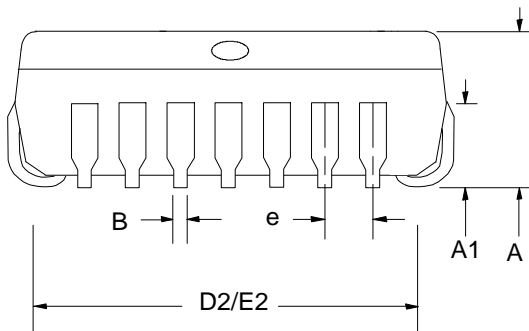
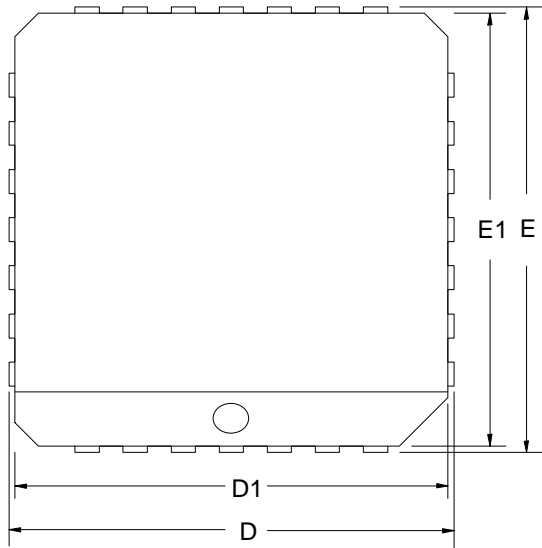

44 pin  
PLCC

DIM	NO. OF TERMINALS					
	MILLIMETERS			INCHES		
	MIN	NOM	MAX	MIN	NOM	MAX
<b>A</b>	4.20	4.45	4.57	0.165	0.175	0.180
<b>A1</b>	2.29	2.79	3.04	0.090	0.110	0.120
<b>B</b>	0.33	0.41	0.53	0.013	0.016	0.021
<b>D/E</b>	17.40	17.53	17.65	0.685	0.690	0.695
<b>D1/E1</b>	16.51	16.59	16.66	0.650	0.653	0.656
<b>D2/E2</b>	14.99	15.50	16.00	0.590	0.610	0.630
<b>e</b>	1.19	1.27	1.35	0.047	0.050	0.053

• Notes •

---

SMART  
Analog™