

5800 AND 5801

BiMOS II LATCHED DRIVERS

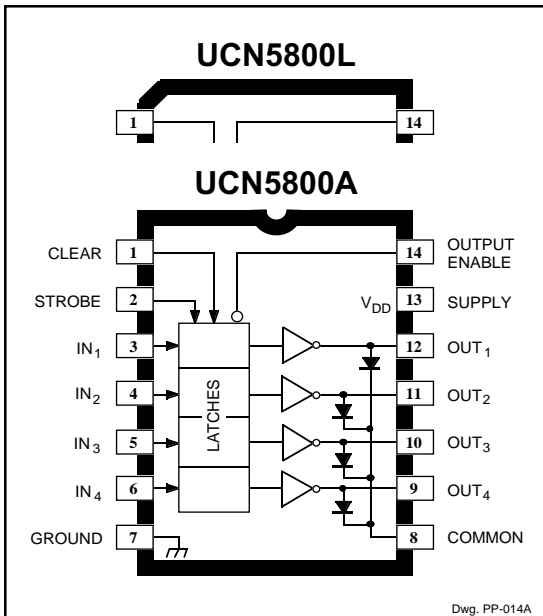

Note the UCN5800A (DIP) and the UCN5800L (SOIC) are electrically identical and share a common terminal number assignment.

ABSOLUTE MAXIMUM RATINGS at +25°C Free-Air Temperature

Output Voltage, V_{CE}	50 V
Supply Voltage, V_{DD}	15 V
Input Voltage Range, V_{IN}	-0.3 V to $V_{DD} + 0.3$ V
Continuous Collector Current, I_C	500 mA
Package Power Dissipation, P_D	See Graph
Operating Temperature Range, T_A	-20°C to +85°C
Storage Temperature Range, T_S	-55°C to +150°C

Caution: CMOS devices have input static protection but are susceptible to damage when exposed to extremely high static electrical charges.

The UCN5800A/L and UCN5801A/EP/LW latched-input BiMOS ICs merge high-current, high-voltage outputs with CMOS logic. The CMOS input section consists of 4 or 8 data ('D' type) latches with associated common CLEAR, STROBE, and OUTPUT ENABLE circuitry. The power outputs are bipolar npn Darlington. This merged technology provides versatile, flexible interface. These BiMOS power interface ICs greatly benefit the simplification of computer or microprocessor I/O. The UCN5800A and UCN5800L each contain four latched drivers; the UCN5801A, UCN5801EP, and UCN5801LW contain eight latched drivers.

The UCN5800A/L and UCN5801A/EP/LW supersede the original BiMOS latched-input driver ICs (UCN4400A and UCN4801A). These second-generation devices are capable of much higher data input rates and will typically operate at better than 5 MHz with a 5 V logic supply. Circuit operation at 12 V affords substantial improvement over the 5 MHz figure.

The CMOS inputs are compatible with standard CMOS and NMOS circuits. TTL circuits may mandate the addition of input pull-up resistors. The bipolar Darlington outputs are suitable for directly driving many peripheral/power loads: relays, lamps, solenoids, small dc motors, etc.

All devices have open-collector outputs and integral diodes for inductive load transient suppression. The output transistors are capable of sinking 500 mA and will withstand at least 50 V in the OFF state. Because of limitations on package power dissipation, the simultaneous operation of all drivers at maximum rated current can only be accomplished by a reduction in duty cycle. Outputs may be paralleled for higher load current capability.

The UCN5800A is furnished in a standard 14-pin DIP; the UCN5800L and UCN5801LW in surface-mountable SOICs; the UCN5801A in a 22-pin DIP with 0.400" (10.16 mm) row centers; the UCN5801EP in a 28-lead PLCC.

FEATURES

- To 4.4 MHz Data Input Rate
- High-Voltage,
High-Current Outputs
- CMOS, NMOS,
TTL Compatible Inputs
- Output Transient Protection
- Internal Pull-Down Resistors
- Low-Power CMOS Latches
- Automotive Capable

Always order by complete part number, e.g., **UCN5801EP**.

5800 AND 5801 BiMOS II LATCHED DRIVERS

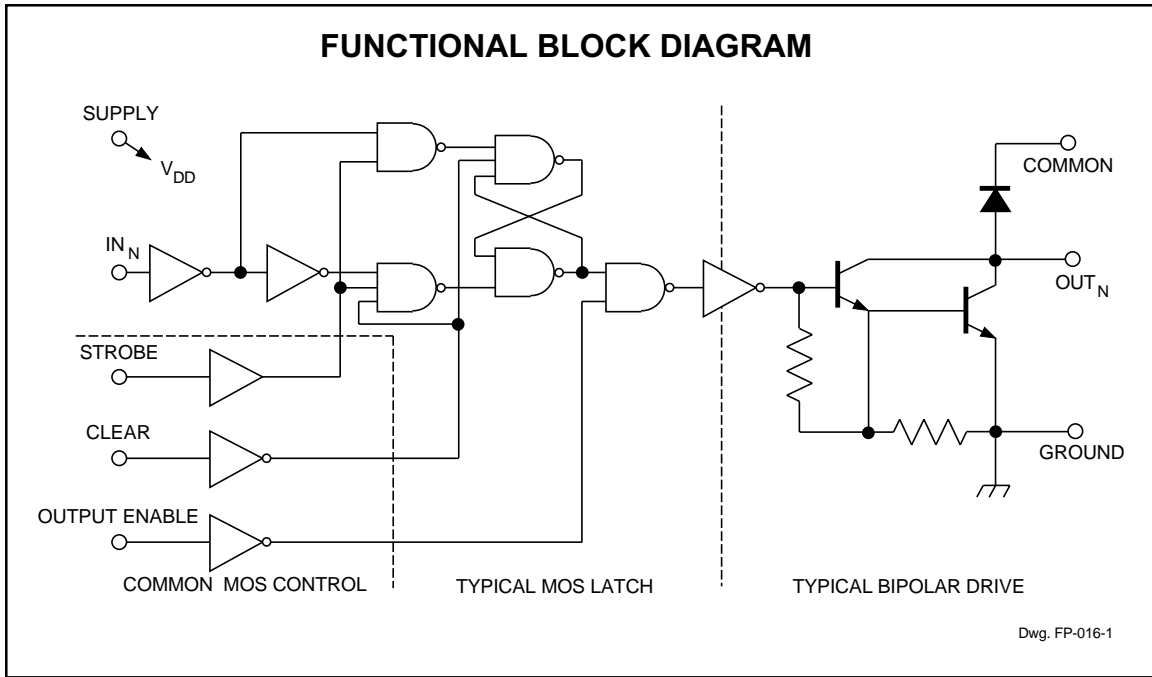

TYPICAL INPUT CIRCUIT

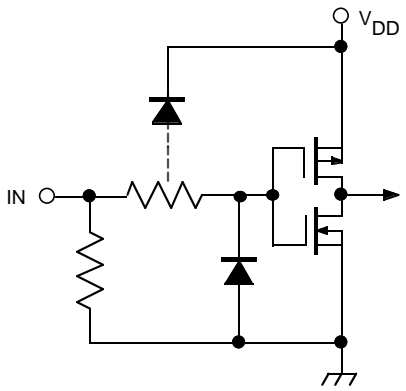

Dwg. EP-010-4A

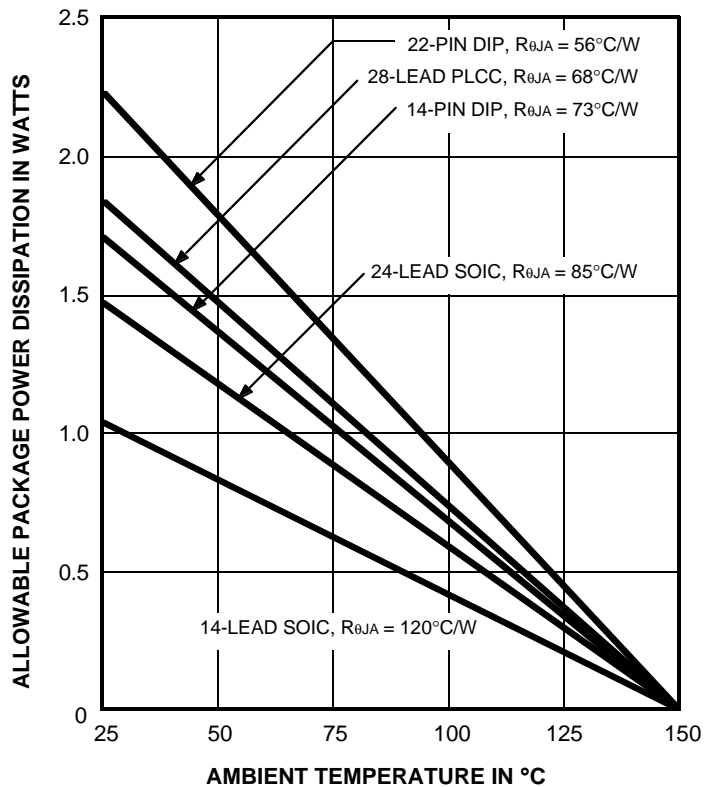

Dwg. GP-023-1A



5800 AND 5801 BiMOS II LATCHED DRIVERS

ELECTRICAL CHARACTERISTICS at $T_A = +25^\circ\text{C}$, $V_{DD} = 5\text{ V}$ (unless otherwise noted).

Characteristic	Symbol	Test Conditions	Limits			Units
			Min.	Typ.	Max.	
Output Leakage Current	I_{CEX}	$V_{CE} = 50\text{ V}$, $T_A = +25^\circ\text{C}$	—	—	50	μA
		$V_{CE} = 50\text{ V}$, $T_A = +70^\circ\text{C}$	—	—	100	μA
Collector-Emitter Saturation Voltage	$V_{CE(SAT)}$	$I_C = 100\text{ mA}$	—	0.9	1.1	V
		$I_C = 200\text{ mA}$	—	1.1	1.3	V
		$I_C = 350\text{ mA}$, $V_{DD} = 7.0\text{ V}$	—	1.3	1.6	V
Input Voltage	$V_{IN(0)}$		—	—	1.0	V
	$V_{IN(1)}$	$V_{DD} = 12\text{ V}$	10.5	—	—	V
		$V_{DD} = 10\text{ V}$	8.5	—	—	V
		$V_{DD} = 5.0\text{ V}$ (See Note)	3.5	—	—	V
Input Resistance	r_{IN}	$V_{DD} = 12\text{ V}$	50	200	—	$\text{k}\Omega$
		$V_{DD} = 10\text{ V}$	50	300	—	$\text{k}\Omega$
		$V_{DD} = 5.0\text{ V}$	50	600	—	$\text{k}\Omega$
Supply Current	$I_{DD(ON)}$ (Each Stage)	$V_{DD} = 12\text{ V}$, Outputs Open	—	1.0	2.0	mA
		$V_{DD} = 10\text{ V}$, Outputs Open	—	0.9	1.7	mA
		$V_{DD} = 5.0\text{ V}$, Outputs Open	—	0.7	1.0	mA
	$I_{DD(OFF)}$ (Total)	$V_{DD} = 12\text{ V}$, Outputs Open, Inputs = 0 V	—	—	200	μA
		$V_{DD} = 5.0\text{ V}$, Outputs Open, Inputs = 0 V	—	50	100	μA
Clamp Diode Leakage Current	I_R	$V_R = 50\text{ V}$, $T_A = +25^\circ\text{C}$	—	—	50	μA
		$V_R = 50\text{ V}$, $T_A = +70^\circ\text{C}$	—	—	100	μA
Clamp Diode Forward Voltage	V_F	$I_F = 350\text{ mA}$	—	1.7	2.0	V

NOTE: Operation of these devices with standard TTL or DTL may require the use of appropriate pull-up resistors to ensure a minimum logic "1".

UCN5801EP
(additional pinout diagrams
are on next page)

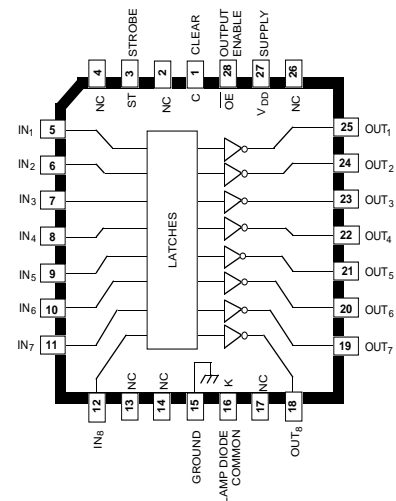

5800 AND 5801 BiMOS II LATCHED DRIVERS

UCN5801A

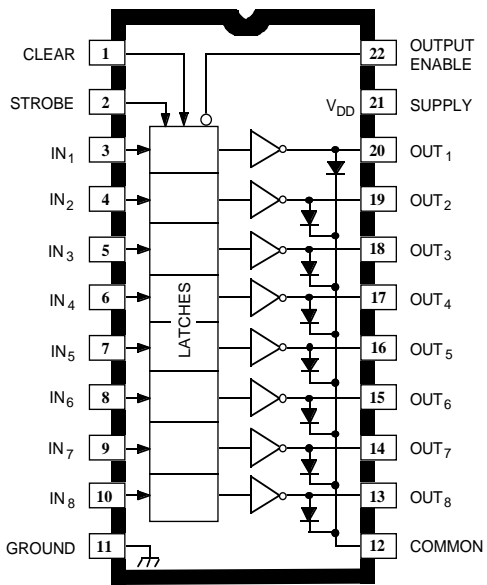

Dwg. PP-015

UCN5801LW

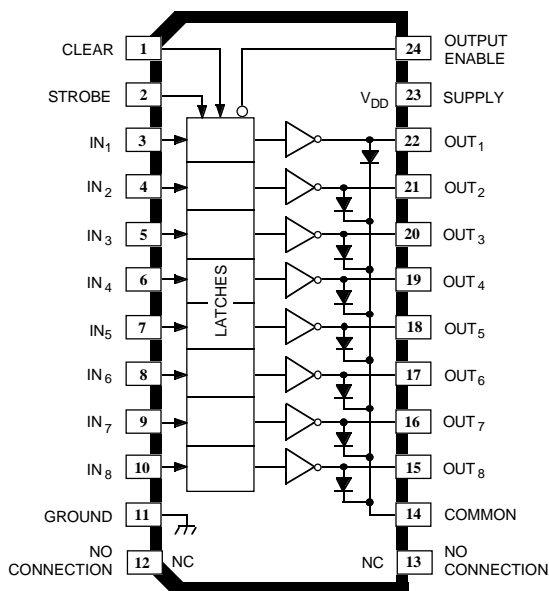

Dwg. PP-015-1

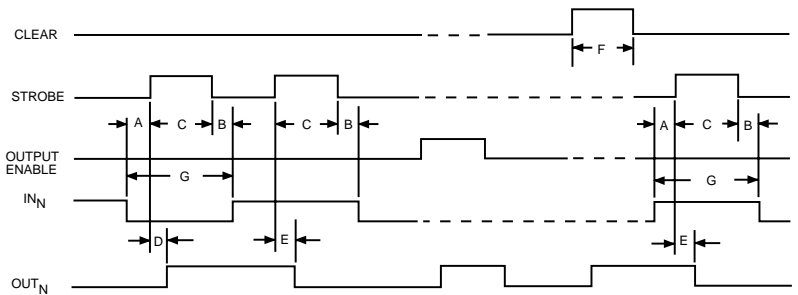

Dwg. No. A-10,895A

TIMING CONDITIONS (Logic Levels are V_{DD} and Ground)

- A. Minimum Data Active Time Before Strobe Enabled (Data Set-Up Time) **50 ns**
- B. Minimum Data Active Time After Strobe Disabled (Data Hold Time) **50 ns**
- C. Minimum Strobe Pulse Width **125 ns**
- D. Typical Time Between Strobe Activation and Output On to Off Transition **500 ns**
- E. Minimum Time Between Strobe Activation and Output Off to On Transition **500 ns**
- F. Minimum Clear Pulse Width **300 ns**
- G. Minimum Data Pulse Width **225 ns**

Information present at an input is transferred to its latch when the STROBE is high. A high CLEAR input will set all latches to the output OFF condition regardless of the data or STROBE input levels. A high OUTPUT ENABLE will set all outputs to the OFF condition, regardless of any other input conditions. When the OUTPUT ENABLE is low, the outputs depend on the state of their respective latches.

TRUTH TABLE

IN _N	STROBE	CLEAR	OUTPUT ENABLE	OUT _N	
				t-1	t
0	1	0	0	X	OFF
1	1	0	0	X	ON
X	X	1	X	X	OFF
X	X	X	1	X	OFF
X	0	0	0	ON	ON
X	0	0	0	OFF	OFF

X = irrelevant.
t-1 = previous output state.
t = present output state.

5800 AND 5801 BiMOS II LATCHED DRIVERS

TYPICAL APPLICATION UNIPOLAR STEPPER-MOTOR DRIVE

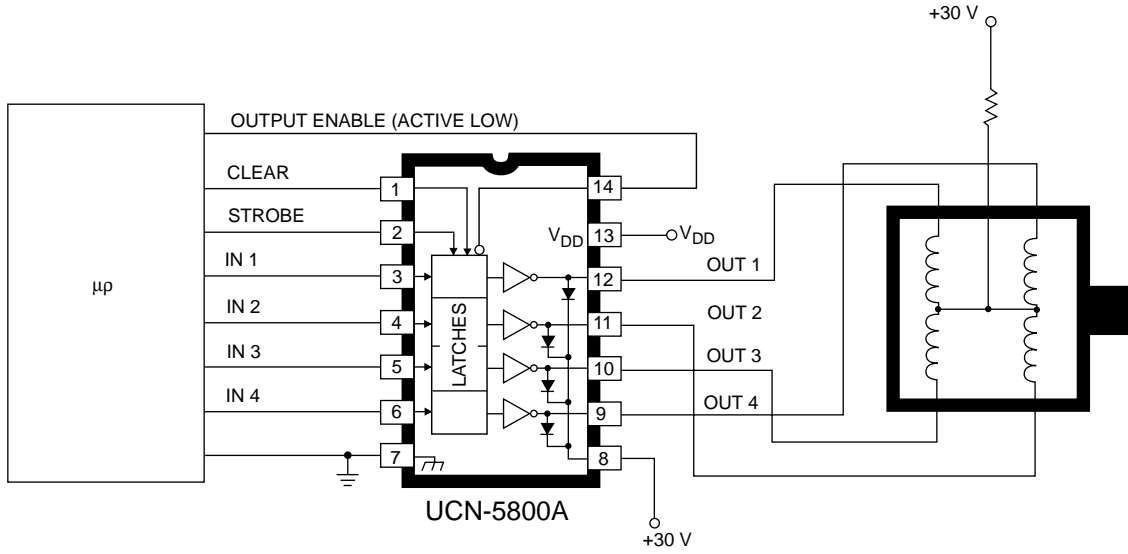

Dwg. No. B-1537

UNIPOLAR WAVE DRIVE

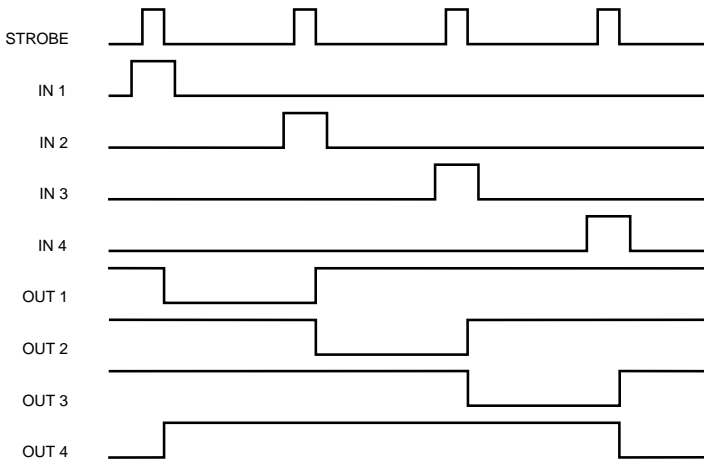

Dwg. GP-060

UNIPOLAR 2-PHASE DRIVE

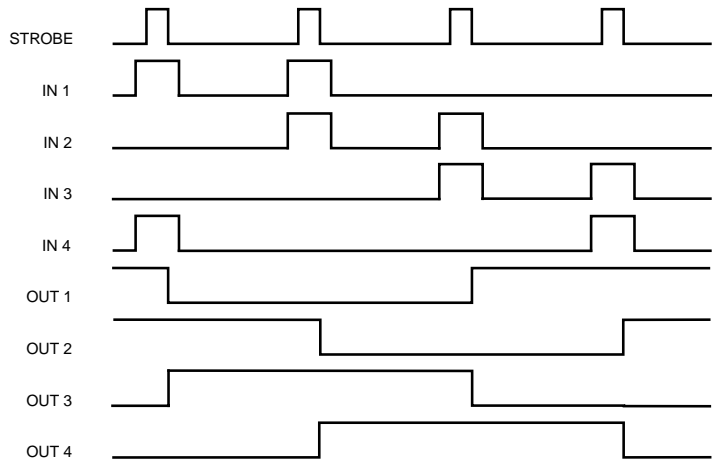

Dwg. GP-060-1

5800 AND 5801
BiMOS II
LATCHED DRIVERS

UCN5800A
 Dimensions in Inches
 (controlling dimensions)

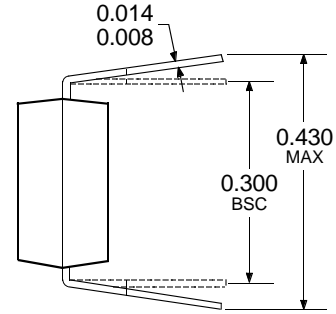
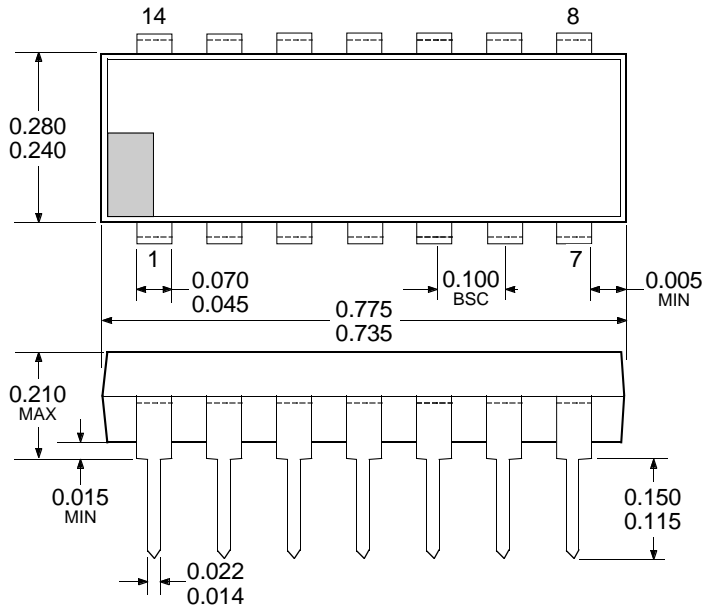

Dwg. MA-001-14A in

Dimensions in Millimeters
 (for reference only)

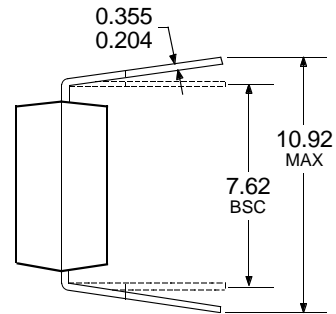
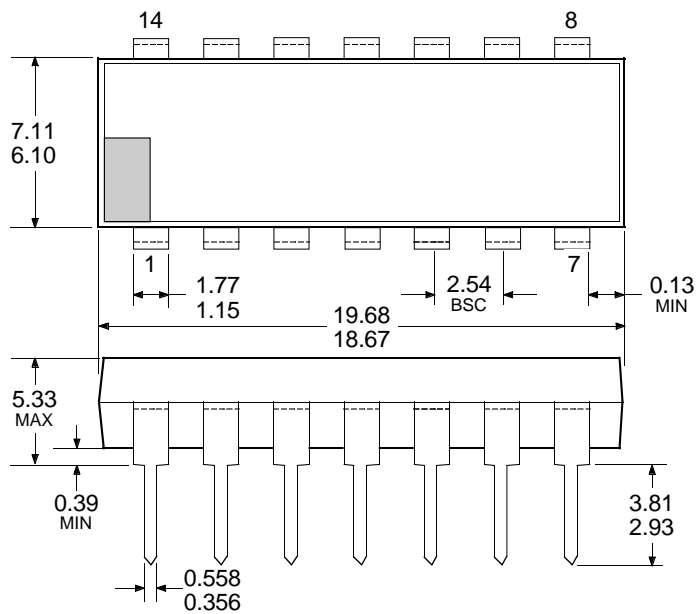

Dwg. MA-001-14A mm

- NOTES: 1. Exact body and lead configuration at vendor's option within limits shown.
 2. Lead spacing tolerance is non-cumulative.
 3. Lead thickness is measured at seating plane or below.

5800 AND 5801 BiMOS II LATCHED DRIVERS

UCN5800L

Dimensions in Inches
(for reference only)

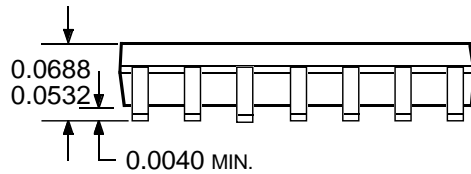
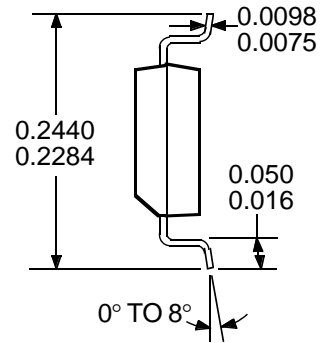
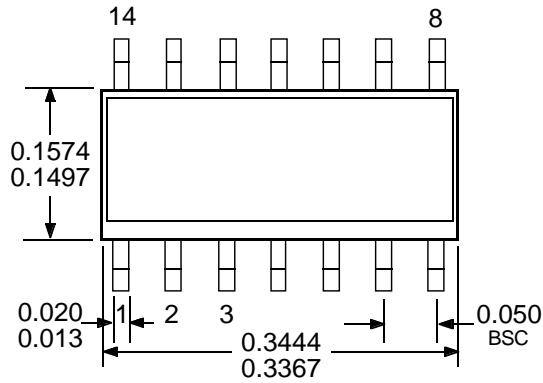

Dwg. MA-007-14 in

Dimensions in Millimeters
(controlling dimensions)

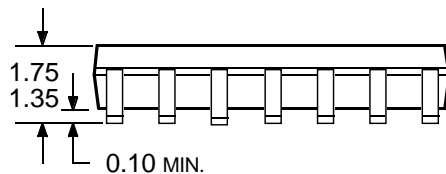
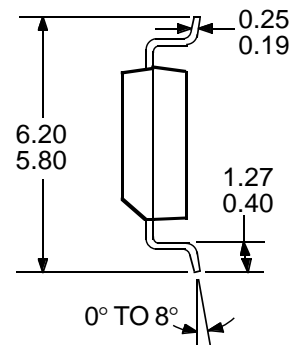
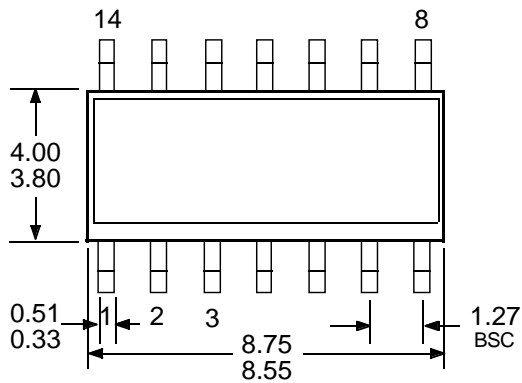

Dwg. MA-007-14A mm

- NOTES: 1. Exact body and lead configuration at vendor's option within limits shown.
2. Lead spacing tolerance is non-cumulative.

5800 AND 5801 BiMOS II LATCHED DRIVERS

UCN5801A Dimensions in Inches (controlling dimensions)

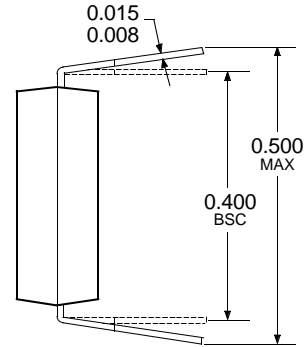
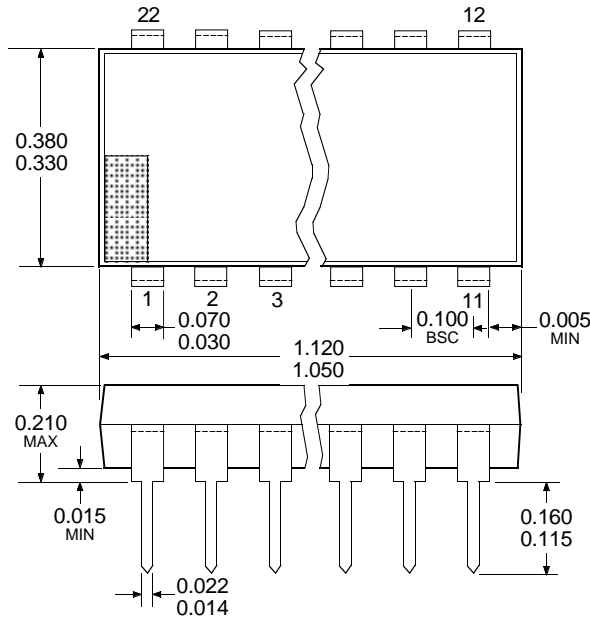

Dwg. MA-002-22 in

Dimensions in Millimeters (for reference only)

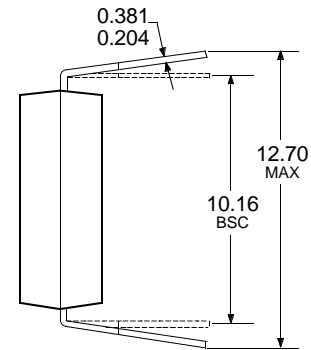
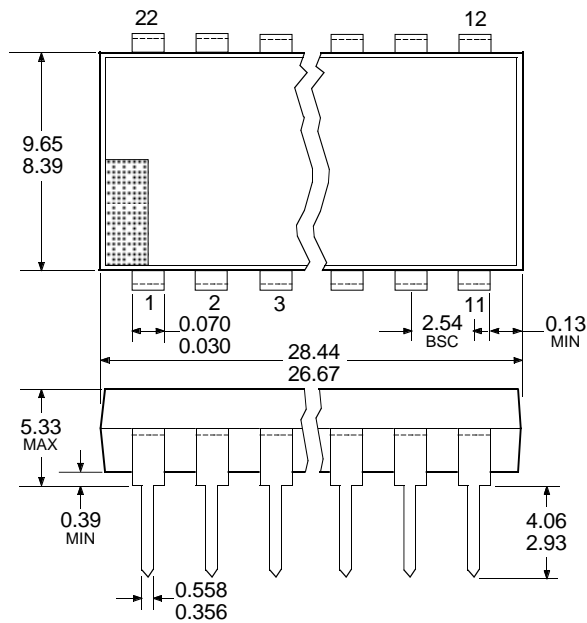

Dwg. MA-002-22 mm

- NOTES: 1. Exact body and lead configuration at vendor's option within limits shown.
2. Lead spacing tolerance is non-cumulative.
3. Lead thickness is measured at seating plane or below.

5800 AND 5801
BiMOS II
LATCHED DRIVERS

UCN5801LW
 Dimensions in Inches
 (for reference only)

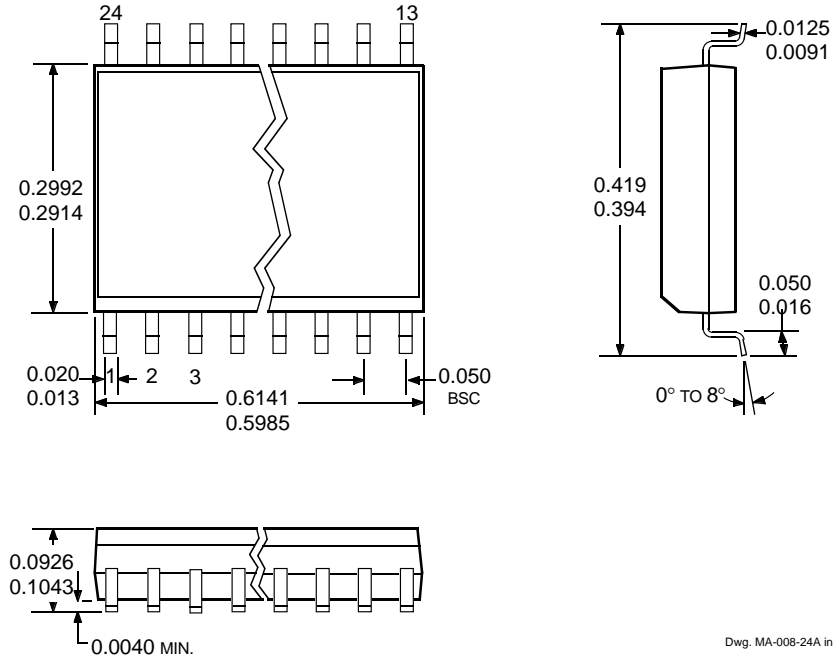

Dimensions in Millimeters
 (controlling dimensions)

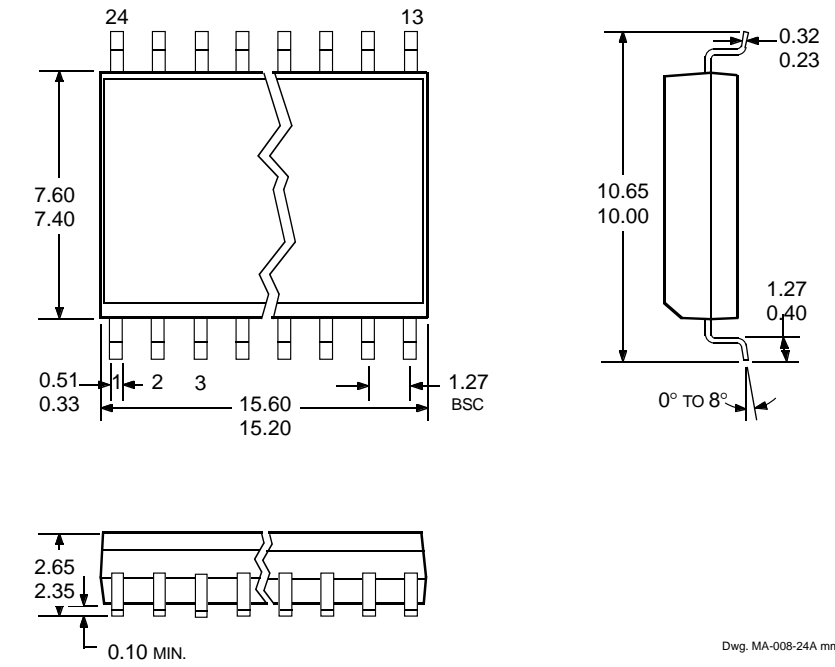

- NOTES: 1. Exact body and lead configuration at vendor's option within limits shown.
 2. Lead spacing tolerance is non-cumulative.



115 Northeast Cutoff, Box 15036
 Worcester, Massachusetts 01615-0036 (508) 853-5000

5800 AND 5801
BiMOS II
LATCHED DRIVERS

This page intentionally left blank

5800 AND 5801
BiMOS II
LATCHED DRIVERS

POWER
INTERFACE DRIVERS

Function	Output Ratings*		Part Number†
SERIAL-INPUT LATCHED DRIVERS			
8-Bit (saturated drivers)	-120 mA	50 V‡	5895
8-Bit	350 mA	50 V	5821
8-Bit	350 mA	80 V	5822
8-Bit	350 mA	50 V‡	5841
8-Bit	350 mA	80 V‡	5842
8-Bit (constant-current LED driver)	75 mA	17 V	6275
8-Bit (constant-current LED driver)	120 mA	24 V	6277
8-Bit (DMOS drivers)	250 mA	50 V	6595
8-Bit (DMOS drivers)	350 mA	50 V‡	6A595
8-Bit (DMOS drivers)	100 mA	50 V	6B595
10-Bit (active pull-downs)	-25 mA	60 V	6810
12-Bit (active pull-downs)	-25 mA	60 V	5811
16-Bit (constant-current LED driver)	75 mA	17 V	6276
20-Bit (active pull-downs)	-25 mA	60 V	6812
32-Bit (active pull-downs)	-25 mA	60 V	6818
32-Bit	100 mA	30 V	5833
32-Bit (saturated drivers)	100 mA	40 V	5832
PARALLEL-INPUT LATCHED DRIVERS			
4-Bit	350 mA	50 V‡	5800
8-Bit	-25 mA	60 V	5815
8-Bit	350 mA	50 V‡	5801
8-Bit (DMOS drivers)	100 mA	50 V	6B273
8-Bit (DMOS drivers)	250 mA	50 V	6273
SPECIAL-PURPOSE DEVICES			
Addressable 8-Bit Decoder/DMOS Driver	250 mA	50 V	6259
Addressable 8-Bit Decoder/DMOS Driver	350 mA	50 V‡	6A259
Addressable 8-Bit Decoder/DMOS Driver	100 mA	50 V	6B259
Addressable 28-Line Decoder/Driver	450 mA	30 V	6817

* Current is maximum specified test condition, voltage is maximum rating. See specification for sustaining voltage limits. Negative current is defined as coming out of (sourcing) the output.

† Complete part number includes additional characters to indicate operating temperature range and package style.

‡ Internal transient-suppression diodes included for inductive-load protection.

Allegro MicroSystems, Inc. reserves the right to make, from time to time, such departures from the detail specifications as may be required to permit improvements in the design of its products.

The information included herein is believed to be accurate and reliable. However, Allegro MicroSystems, Inc. assumes no responsibility for its use; nor for any infringements of patents or other rights of third parties which may result from its use.

