

50mA CMOS LDO WITH SHUTDOWN AND REFERENCE BYPASS

FEATURES

- Zero Ground Current for Longer Battery Life!
- Very Low Dropout Voltage
- Guaranteed 50mA Output
- High Output Voltage Accuracy
- Standard or Custom Output Voltages
- Power-Saving Shutdown Mode
- Reference Bypass Input for Ultra Low-Noise Operation
- Over-Current and Over-Temperature Protection
- Space-Saving SOT-23A-5 Package
- Pin Compatible Upgrade for MIC5205 and NSC2980

APPLICATIONS

- Battery Operated Systems
- Portable Computers
- Medical Instruments
- Instrumentation
- Cellular / GSM / PHS Phones
- Linear Post-Regulator for SMPS
- Pagers

TYPICAL APPLICATION

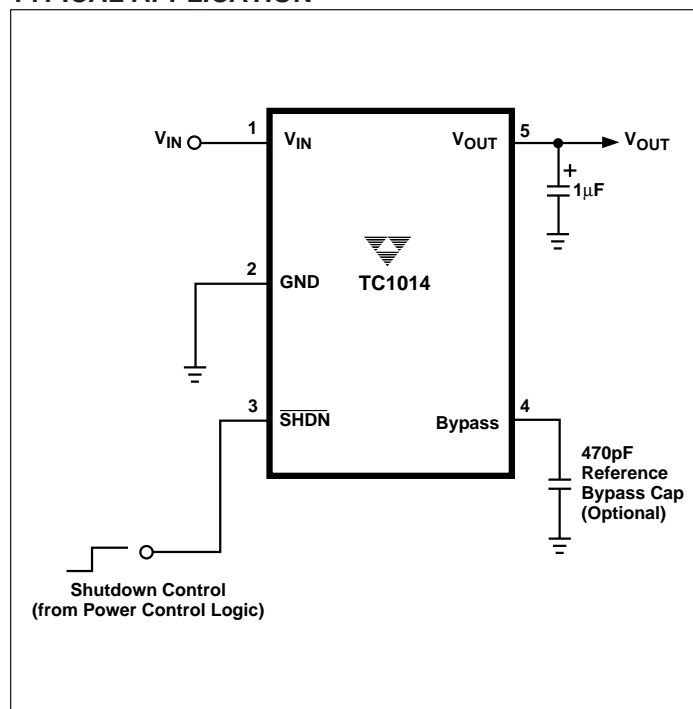

GENERAL DESCRIPTION

The TC1014 is a high accuracy (typically $\pm 0.5\%$) CMOS upgrade for older (bipolar) low dropout regulators such as the LP2980. Designed specifically for battery-operated systems, the TC1014's CMOS construction eliminates wasted ground current, significantly extending battery life. Total supply current is typically $50\mu\text{A}$ at full load (*20 to 60 times lower than in bipolar regulators!*).

TC1014 key features include ultra low-noise operation (plus optional Bypass input); very low dropout voltage (typically 95mV at full load) and internal feed-forward compensation for fast response to step changes in load. Supply current is reduced to less than $1\mu\text{A}$ when the shutdown input is low. The TC1014 also incorporates both over-temperature and over-current protection.

The TC1014 is stable with an output capacitor of only $1\mu\text{F}$ and has a maximum output current of 100mA. For higher output versions, please see the TC1107, TC1108, TC1173 ($I_{\text{OUT}} = 300\text{mA}$) data sheets.

ORDERING INFORMATION

Part No.	Output Voltage ** (V)	Package	Junction Temp. Range
TC1014-2.5VCT	2.5	SOT-23A-5*	-40°C to +125°C
TC1014-2.7VCT	2.7	SOT-23A-5*	-40°C to +125°C
TC1014-3.0VCT	3.0	SOT-23A-5*	-40°C to +125°C
TC1014-3.3VCT	3.3	SOT-23A-5*	-40°C to +125°C
TC1014-5.0VCT	5.0	SOT-23A-5*	-40°C to +125°C

NOTE: *SOT-23A-5 is equivalent to the EIAJ (SC-74A)
 ** Other output voltages available. Please contact TelCom Semiconductor for details

PIN CONFIGURATION

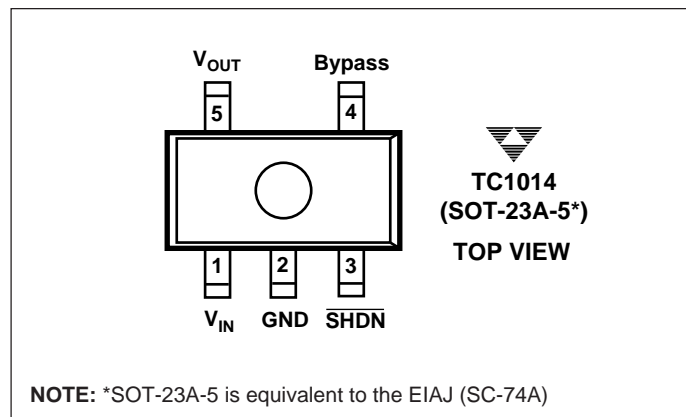

NOTE: *SOT-23A-5 is equivalent to the EIAJ (SC-74A)

TC1014

ABSOLUTE MAXIMUM RATINGS*

Input Voltage	7V
Output Voltage	(− 0.3) to (V _{IN} + 0.3)
Power Dissipation	Internally Limited (Note 7)
Operating Temperature	− 40°C < T _J < 125°C
Storage Temperature	− 65°C to +150°C
Maximum Voltage On Any Pin	V _{IN} + 0.3V to − 0.3V

*Stresses beyond those listed under "Absolute Maximum Ratings" may cause permanent damage to the device. These are stress ratings only, and functional operation of the device at these or any other conditions beyond those indicated in the operational sections of the specifications is not implied. Exposure to absolute maximum rating conditions for extended periods may affect device reliability.

ELECTRICAL CHARACTERISTICS: V_{IN} = V_{OUT} + 1V, I_L = 100μA, C_L = 3.3μF, $\overline{\text{SHDN}} > V_{IH}$, T_A = 25°C, unless otherwise noted.
Boldface type specifications apply for junction temperatures of − 40°C to +125°C.

Symbol	Parameter	Test Conditions	Min	Typ	Max	Units
V _{IN}	Input Operating Voltage		—	—	6.5	V
I _{OUTMAX}	Maximum Output Current		50	—	—	mA
V _{OUT}	Output Voltage	Note 1	V_R − 2.5%	V _R ±0.5%	V_R + 2.5%	V
TCV _{OUT}	V _{OUT} Temperature Coefficient	Note 2		20 40	—	ppm/°C
ΔV _{OUT} /ΔV _{IN}	Line Regulation	(V _R + 1V) ≤ V _{IN} ≤ 6V	—	0.01	—	%
ΔV _{OUT} /V _{OUT}	Load Regulation	I _L = 1.0mA to I _{OUTMAX} (Note 3)	—	0.5	—	%
V _{IN} − V _{OUT}	Dropout Voltage (Note 4)	I _L = 100μA I _L = 20mA I _L = 50mA (Note 4)	—	5 65 95	—	mV
I _{GND}	Ground Pin Current	I _L = I _{OUTMAX} , (Note 5)	—	—	0	μA
I _{IN}	Supply Current	$\overline{\text{SHDN}} = V_{IH}$, I _L = 0	—	50	—	μA
I _{INSD}	Shutdown Supply Current	$\overline{\text{SHDN}} = 0V$	—	—	0.05	μA
PSRR	Power Supply Rejection Ratio	F _{RE} ≤ 1kHz	—	64	—	dB
I _{OUTSC}	Output Short Circuit Current	V _{OUT} = 0V	—	200	400	mA
ΔV _{OUT} /ΔP _D	Thermal Regulation	Note 6	—	0.04	—	%/W
eN	Output Noise	I _L = I _{OUTMAX} 470pF from Bypass to GND	—	260	—	nV/√Hz

SHDN Input

V _{IH}	$\overline{\text{SHDN}}$ Input High Threshold	V _{IN} = 2.5V to 6.5V	45	—	—	%V _{IN}
V _{IL}	$\overline{\text{SHDN}}$ Input Low Threshold	V _{IN} = 2.5V to 6.5V	—	—	15	%V _{IN}

NOTES: 1. V_R is the regulator output voltage setting. V_R = 2.5V, 2.7V, 3.0V, 3.3V, 5.0V.

$$2. \text{TCV}_{\text{OUT}} = \frac{(V_{\text{OUTMAX}} - V_{\text{OUTMIN}}) \times 10^6}{V_{\text{OUT}} \times \Delta T}$$

- Regulation is measured at a constant junction temperature using low duty cycle pulse testing. Load regulation is tested over a load range from 1.0mA to the maximum specified output current. Changes in output voltage due to heating effects are covered by the thermal regulation specification.
- Dropout voltage is defined as the input to output differential at which the output voltage drops 2% below its nominal value at a 1V differential.
- Ground pin current is the regulator pass transistor gate current. The total current drawn from the input supply is the sum of the load current, ground current and supply current (i.e. I_{IN} = I_{SUPPLY} + I_{GND} + I_{LOAD}).
- Thermal Regulation is defined as the change in output voltage at a time T after a change in power dissipation is applied, excluding load or line regulation effects. Specifications are for a current pulse equal to I_{LMAX} at V_{IN} = 6V for T = 10msec.
- The maximum allowable power dissipation is a function of ambient temperature, the maximum allowable junction temperature and the thermal resistance from junction-to-air (i.e. T_A, T_J, θ_{JA}). Exceeding the maximum allowable power dissipation causes the device to initiate thermal shutdown. Please see *Thermal Considerations* section of this data sheet for more details.

PIN DESCRIPTION

Pin No. (SOT-23A-5)	Symbol	Description
1	V_{IN}	Unregulated supply input.
2	GND	Ground terminal.
3	\overline{SHDN}	Shutdown control input. The regulator is fully enabled when a logic high is applied to this input. The regulator enters shutdown when a logic low is applied to this input. During shutdown, output voltage falls to zero, and supply current is reduced to under 1 microamp (typical).
4	Bypass	Reference bypass input. Connecting a 470pF to this input further reduces output noise.
5	V_{OUT}	Regulated voltage output.

DETAILED DESCRIPTION

The TC1014 is a precision fixed output voltage regulator. (If an adjustable version is desired, please see the TC1070 or TC1071 data sheets.) Unlike the bipolar regulators, the TC1014 supply current does not increase with load current. In addition, V_{OUT} remains stable and within regulation at very low load currents (an important consideration in RTC and CMOS RAM battery back-up applications).

Figure 1 shows a typical application circuit. The regulator is enabled any time the shutdown input (\overline{SHDN}) is at or above V_{IH} , and shutdown (disabled) when \overline{SHDN} is at or below V_{IL} . \overline{SHDN} may be controlled by a CMOS logic gate, or I/O port of a microcontroller. If the \overline{SHDN} input is not required, it should be connected directly to the input supply. While in shutdown, supply current decreases to 0.05 μ A (typical) and V_{OUT} falls to zero volts.

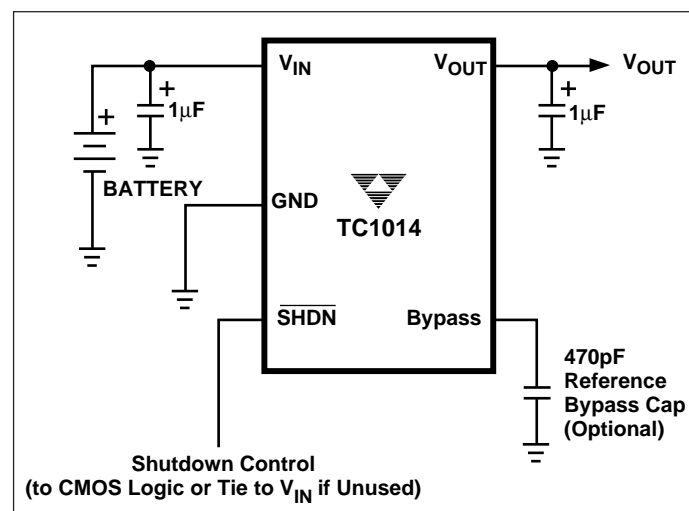

Figure 1. Typical Application Circuit

Bypass Input

A 470pF capacitor connected from the Bypass input to ground reduces noise present on the internal reference, which in turn significantly reduces output noise. If output

noise is not a concern, this input may be left unconnected. Larger capacitor values may be used, but results in a longer time period to rated output voltage when power is initially applied.

Output Capacitor

A 1 μ F (min) capacitor from V_{OUT} to ground is recommended. The output capacitor should have an effective series resistance of 5 Ω or less, and a resonant frequency above 1MHz. A 1 μ F capacitor should be connected from V_{IN} to GND if there is more than 10 inches of wire between the regulator and the AC filter capacitor, or if a battery is used as the power source. Aluminum electrolytic or tantalum capacitor types can be used. (Since many aluminum electrolytic capacitors freeze at approximately -30°C , solid tantalums are recommended for applications operating below -25°C .) When operating from sources other than batteries, supply-noise rejection and transient response can be improved by increasing the value of the input and output capacitors and employing passive filtering techniques.

Thermal Considerations

Thermal Shutdown

Integrated thermal protection circuitry shuts the regulator off when die temperature exceeds 160°C . The regulator remains off until the die temperature drops to approximately 150°C .

Power Dissipation

The amount of power the regulator dissipates is primarily a function of input and output voltage, and output current. The following equation is used to calculate worst case *actual* power dissipation:

TC1014

$$P_D \approx (V_{INMAX} - V_{OUTMIN}) I_{LOADMAX}$$

Where:

P_D = Worst case actual power dissipation

V_{INMAX} = Maximum voltage on V_{IN}

V_{OUTMIN} = Minimum regulator output voltage

$I_{LOADMAX}$ = Maximum output (load) current

Equation 1.

The maximum *allowable* power dissipation (Equation 2) is a function of the maximum ambient temperature (T_{AMAX}), the maximum allowable die temperature (125°C) and the thermal resistance from junction-to-air (θ_{JA}). The SOT-23A-5 package has a θ_{JA} of approximately 220°C/Watt when mounted on a single layer FR4 dielectric copper clad PC board.

$$P_{D MAX} = \frac{(T_{JMAX} - T_{JMAX})}{\theta_{JA}}$$

Where all terms are previously defined.

Equation 2.

Equation 1 can be used in conjunction with Equation 2 to ensure regulator thermal operation is within limits. For example:

Given:

$$V_{INMAX} = 3.0V \pm 5\%$$

$$V_{OUTMIN} = 2.7V \pm 0.5V$$

$$I_{LOAD} = 40mA$$

$$T_{AMAX} = 55^\circ C$$

- Find:
1. Actual power dissipation
 2. Maximum allowable dissipation

Actual power dissipation:

$$\begin{aligned} P_D &\approx (V_{INMAX} - V_{OUTMIN}) I_{LOADMAX} \\ &= [(3.0 \times 1.1) - (2.7 \times .995)] 40 \times 10^{-3} \\ &= 18.5mW \end{aligned}$$

Maximum allowable power dissipation:

$$\begin{aligned} P_{D MAX} &= \frac{(T_{JMAX} - T_{AMAX})}{\theta_{JA}} \\ &= \frac{(125 - 55)}{220} \\ &= 318mW \end{aligned}$$

In this example, the TC1014 dissipates a maximum of only 60mW; far below the allowable limit of 318mW. In a similar manner, Equation 1 and Equation 2 can be used to calculate maximum current and/or input voltage limits. For example, the maximum allowable V_{IN} is found by substituting the maximum allowable power dissipation of 318mW into Equation 1, from which $V_{INMAX} = 5.9V$.

Layout Considerations

The primary path of heat conduction out of the package is via the package leads. Therefore, layouts having a ground plane, wide traces at the pads, and wide power supply bus lines combine to lower θ_{JA} and, therefore, increase the maximum allowable power dissipation limit.

50mA CMOS LDO WITH SHUTDOWN AND REFERENCE BYPASS

PRELIMINARY INFORMATION

TC1014

MARKING

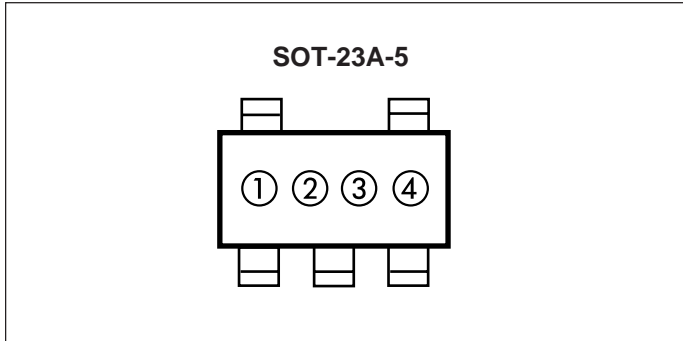

① & ② = part number code + temperature range and voltage

TC1014 (V)	Code
2.5	A1
2.7	A2
3.0	A3
3.3	A5
5.0	A7

③ represents year and quarter code

④ represents lot ID number

PACKAGE DIMENSIONS

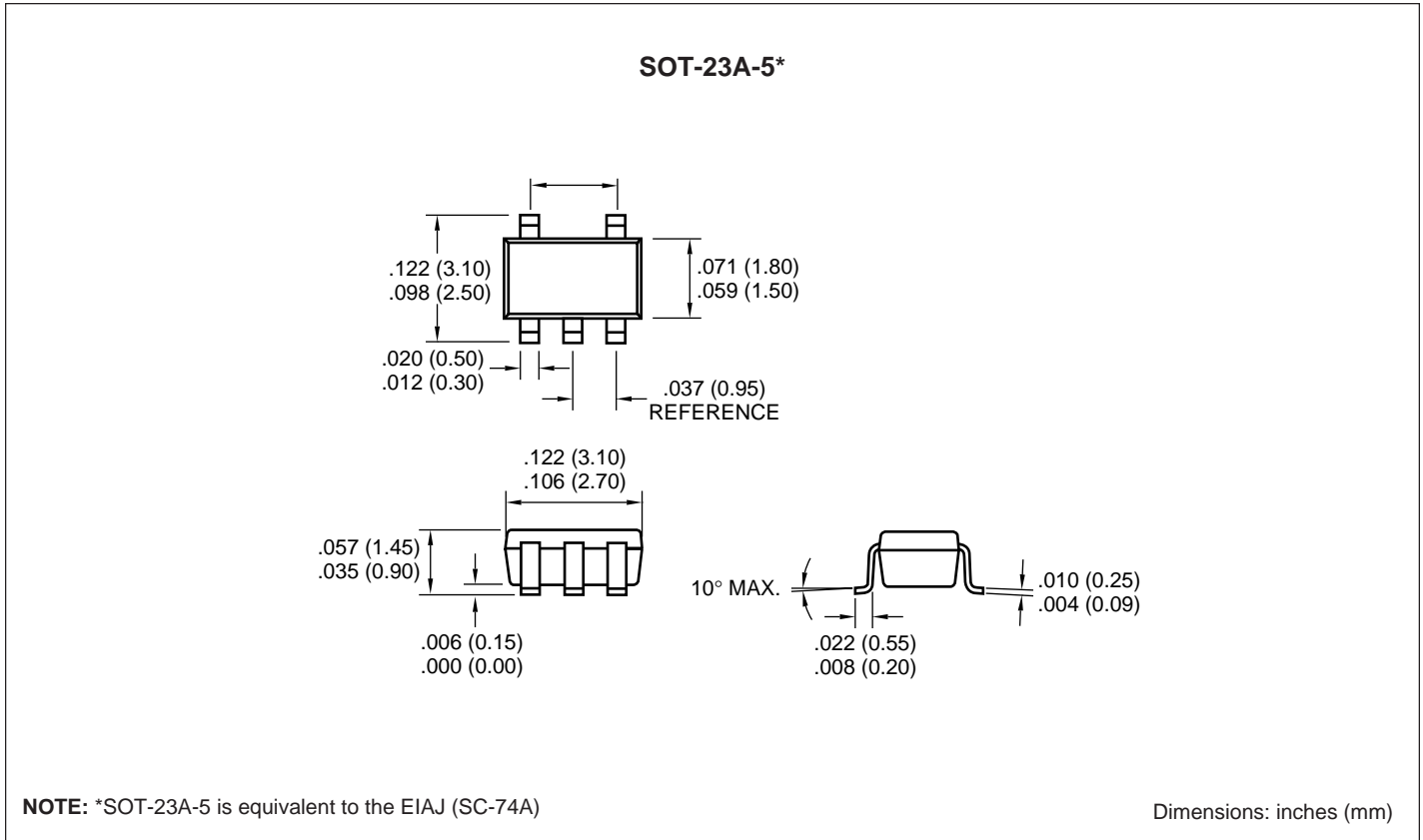

Sales Offices

TelCom Semiconductor
 1300 Terra Bella Avenue
 P.O. Box 7267
 Mountain View, CA 94039-7267
 TEL: 415-968-9241
 FAX: 415-967-1590
 E-Mail: liter@c2smtp.telcom-semi.com

TelCom Semiconductor
 Austin Product Center
 9101 Burnet Rd. Suite 214
 Austin, TX 78758
 TEL: 512-873-7100
 FAX: 512-873-8236

TelCom Semiconductor H.K. Ltd.
 10 Sam Chuk Street, 6/F
 San Po Kong
 Kowloon
 Hong Kong
 TEL: 852-2324-0122
 FAX: 852-2354-9957

100mA CMOS LDO WITH SHUTDOWN AND REFERENCE BYPASS

FEATURES

- Zero Ground Current for Longer Battery Life!
- Very Low Dropout Voltage
- Guaranteed 100mA Output
- High Output Voltage Accuracy
- Standard or Custom Output Voltages
- Power-Saving Shutdown Mode
- Reference Bypass Input for Ultra Low-Noise Operation
- Over-Current and Over-Temperature Protection
- Space-Saving SOT-23A-5 Package
- Pin Compatible Upgrade for MIC5205 and NSC2980

APPLICATIONS

- Battery Operated Systems
- Portable Computers
- Medical Instruments
- Instrumentation
- Cellular / GSM / PHS Phones
- Linear Post-Regulator for SMPS
- Pagers

TYPICAL APPLICATION

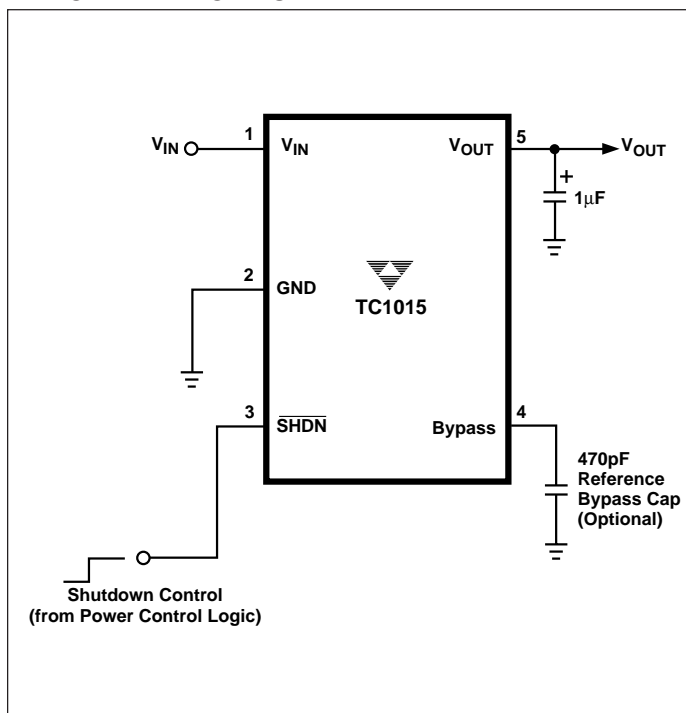

GENERAL DESCRIPTION

The TC1015 is a high accuracy (typically $\pm 0.5\%$) CMOS upgrade for older (bipolar) low dropout regulators such as the LP2980. Designed specifically for battery-operated systems, the TC1015's CMOS construction eliminates wasted ground current, significantly extending battery life. Total supply current is typically $50\mu\text{A}$ at full load (*20 to 60 times lower than in bipolar regulators!*).

TC1015 key features include ultra low-noise operation (plus optional Bypass input); very low dropout voltage (typically 200mV at full load) and internal feed-forward compensation for fast response to step changes in load. Supply current is reduced to $0.05\mu\text{A}$ and V_{OUT} is disabled when the shutdown input is low. The TC1015 also incorporates both over-temperature and over-current protection.

The TC1015 is stable with an output capacitor of only $1\mu\text{F}$ and has a maximum output current of 100mA. For higher output versions, please see the TC1107, TC1108, TC1173 ($I_{\text{OUT}} = 300\text{mA}$) data sheets.

ORDERING INFORMATION

Part No.	Output Voltage ** (V)	Package	Junction Temp. Range
TC1015-2.5VCT	2.5	SOT-23A-5*	-40°C to +125°C
TC1015-2.7VCT	2.7	SOT-23A-5*	-40°C to +125°C
TC1015-3.0VCT	3.0	SOT-23A-5*	-40°C to +125°C
TC1015-3.3VCT	3.3	SOT-23A-5*	-40°C to +125°C
TC1015-5.0VCT	5.0	SOT-23A-5*	-40°C to +125°C

NOTE: *SOT-23A-5 is equivalent to the EIAJ (SC-74A)

** Other output voltages available. Please contact TelCom Semiconductor for details

PIN CONFIGURATION

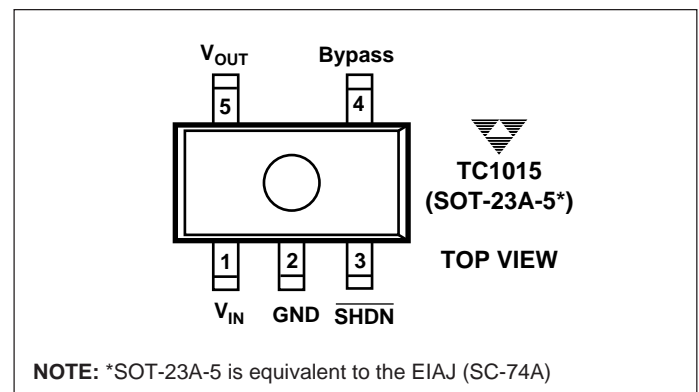

NOTE: *SOT-23A-5 is equivalent to the EIAJ (SC-74A)

TC1015

ABSOLUTE MAXIMUM RATINGS*

Input Voltage	7V
Output Voltage	(- 0.3) to (V _{IN} + 0.3)
Power Dissipation	Internally Limited (Note 7)
Operating Temperature	- 40°C < T _J < 125°C
Storage Temperature	- 65°C to +150°C
Maximum Voltage On Any Pin	V _{IN} + 0.3V to - 0.3V

*Stresses beyond those listed under "Absolute Maximum Ratings" may cause permanent damage to the device. These are stress ratings only, and functional operation of the device at these or any other conditions beyond those indicated in the operational sections of the specifications is not implied. Exposure to absolute maximum rating conditions for extended periods may affect device reliability.

ELECTRICAL CHARACTERISTICS: V_{IN} = V_{OUT} + 1V, I_L = 100μA, C_L = 3.3μF, $\overline{\text{SHDN}} > V_{IH}$, T_A = 25°C, unless otherwise noted.
Boldface type specifications apply for junction temperatures of - 40°C to +125°C.

Symbol	Parameter	Test Conditions	Min	Typ	Max	Units
V _{IN}	Input Operating Voltage		—	—	6.5	V
I _{OUTMAX}	Maximum Output Current		100	—	—	mA
V _{OUT}	Output Voltage	Note 1	V_R - 2.5%	V _R ±0.5%	V_R + 2.5%	V
TCV _{OUT}	V _{OUT} Temperature Coefficient	Note 2		20 40	—	ppm/°C
ΔV _{OUT} /ΔV _{IN}	Line Regulation	(V _R + 1V) ≤ V _{IN} ≤ 6V	—	0.01	—	%
ΔV _{OUT} /V _{OUT}	Load Regulation	I _L = 1.0mA to I _{OUTMAX} (Note 3)	—	0.5	—	%
V _{IN} - V _{OUT}	Dropout Voltage (Note 4)	I _L = 0.1mA I _L = 20mA I _L = 50mA I _L = 100mA (Note 4)	—	20 70 93 112	—	mV
I _{GND}	Ground Pin Current	I _L = I _{OUTMAX} , (Note 5)	—	—	0	μA
I _{IN}	Supply Current	$\overline{\text{SHDN}} = V_{IH}$, I _L = 0	—	50	—	μA
I _{INSD}	Shutdown Supply Current	$\overline{\text{SHDN}} = 0V$	—	—	0.05	μA
PSRR	Power Supply Rejection Ratio	F _{RE} ≤ 1kHz	—	64	—	dB
I _{OUTSC}	Output Short Circuit Current	V _{OUT} = 0V	—	300	500	mA
ΔV _{OUT} /ΔP _D	Thermal Regulation	Note 6	—	0.04	—	%/W
eN	Output Noise	I _L = I _{OUTMAX} 470pF from Bypass to GND	—	260	—	nV/√Hz

SHDN Input

V _{IH}	SHDN Input High Threshold	V _{IN} = 2.5V to 6.5V	45	—	—	%V _{IN}
V _{IL}	SHDN Input Low Threshold	V _{IN} = 2.5V to 6.5V	—	—	15	%V _{IN}

NOTES: 1. V_R is the regulator output voltage setting. V_R = 2.5V, 2.7V, 3.0V, 3.3V, 5.0V.

$$2. \text{TCV}_{\text{OUT}} = \frac{(V_{\text{OUTMAX}} - V_{\text{OUTMIN}}) \times 10^6}{V_{\text{OUT}} \times \Delta T}$$

- Regulation is measured at a constant junction temperature using low duty cycle pulse testing. Load regulation is tested over a load range from 1.0mA to the maximum specified output current. Changes in output voltage due to heating effects are covered by the thermal regulation specification.
- Dropout voltage is defined as the input to output differential at which the output voltage drops 2% below its nominal value at a 1V differential.
- Ground pin current is the regulator pass transistor gate current. The total current drawn from the input supply is the sum of the load current, ground current and supply current (i.e. I_{IN} = I_{SUPPLY} + I_{GND} + I_{LOAD}).
- Thermal Regulation is defined as the change in output voltage at a time T after a change in power dissipation is applied, excluding load or line regulation effects. Specifications are for a current pulse equal to I_{LMAX} at V_{IN} = 6V for T = 10msec.
- The maximum allowable power dissipation is a function of ambient temperature, the maximum allowable junction temperature and the thermal resistance from junction-to-air (i.e. T_A, T_J, θ_{JA}). Exceeding the maximum allowable power dissipation causes the device to initiate thermal shutdown. Please see *Thermal Considerations* section of this data sheet for more details.

PIN DESCRIPTION

Pin No. (SOT-23A-5)	Symbol	Description
1	V_{IN}	Unregulated supply input.
2	GND	Ground terminal.
3	$\overline{\text{SHDN}}$	Shutdown control input. The regulator is fully enabled when a logic high is applied to this input. The regulator enters shutdown when a logic low is applied to this input. During shutdown, output voltage falls to zero, and supply current is reduced to under 1 microamp (typical).
4	Bypass	Reference bypass input. Connecting a 470pF to this input further reduces output noise.
5	V_{OUT}	Regulated voltage output.

DETAILED DESCRIPTION

The TC1015 is a precision fixed output voltage regulator. (If an adjustable version is desired, please see the TC1070 or TC1071 data sheets.) Unlike the bipolar regulators, the TC1015 supply current does not increase with load current. In addition, V_{OUT} remains stable and within regulation at very low load currents (an important consideration in RTC and CMOS RAM battery back-up applications).

Figure 1 shows a typical application circuit. The regulator is enabled any time the shutdown input ($\overline{\text{SHDN}}$) is at or above V_{IH} , and shutdown (disabled) when $\overline{\text{SHDN}}$ is at or below V_{IL} . $\overline{\text{SHDN}}$ may be controlled by a CMOS logic gate, or I/O port of a microcontroller. If the $\overline{\text{SHDN}}$ input is not required, it should be connected directly to the input supply. While in shutdown, supply current decreases to 0.05 μA (typical) and V_{OUT} falls to zero volts.

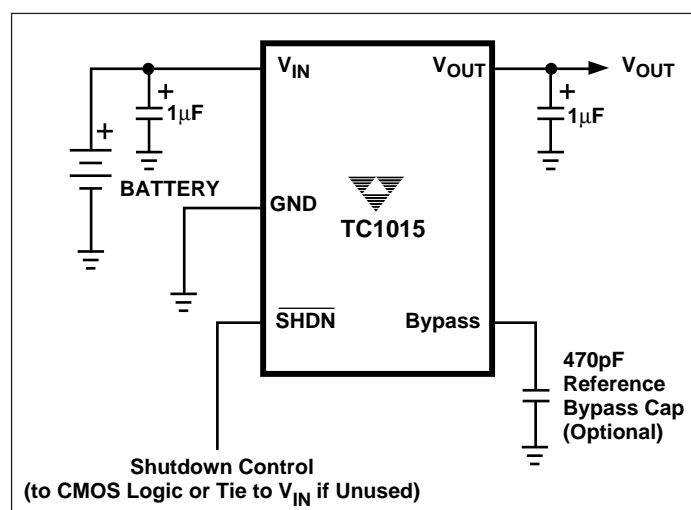

Figure 1. Typical Application Circuit

Bypass Input

A 470pF capacitor connected from the Bypass input to ground reduces noise present on the internal reference, which in turn significantly reduces output noise. If output

noise is not a concern, this input may be left unconnected. Larger capacitor values may be used, but results in a longer time period to rated output voltage when power is initially applied.

Output Capacitor

A 1 μF (min) capacitor from V_{OUT} to ground is recommended. The output capacitor should have an effective series resistance of 5 Ω or less, and a resonant frequency above 1MHz. A 1 μF capacitor should be connected from V_{IN} to GND if there is more than 10 inches of wire between the regulator and the AC filter capacitor, or if a battery is used as the power source. Aluminum electrolytic or tantalum capacitor types can be used. (Since many aluminum electrolytic capacitors freeze at approximately -30°C , solid tantalums are recommended for applications operating below -25°C .) When operating from sources other than batteries, supply-noise rejection and transient response can be improved by increasing the value of the input and output capacitors and employing passive filtering techniques.

Thermal Considerations

Thermal Shutdown

Integrated thermal protection circuitry shuts the regulator off when die temperature exceeds 160°C . The regulator remains off until the die temperature drops to approximately 150°C .

Power Dissipation

The amount of power the regulator dissipates is primarily a function of input and output voltage, and output current. The following equation is used to calculate worst case *actual* power dissipation:

TC1015

$$P_D \approx (V_{IN_{MAX}} - V_{OUT_{MIN}})I_{LOAD_{MAX}}$$

Where:

P_D = Worst case actual power dissipation

$V_{IN_{MAX}}$ = Maximum voltage on V_{IN}

$V_{OUT_{MIN}}$ = Minimum regulator output voltage

$I_{LOAD_{MAX}}$ = Maximum output (load) current

Equation 1.

The maximum *allowable* power dissipation (Equation 2) is a function of the maximum ambient temperature (T_{AMAX}), the maximum allowable die temperature (125°C) and the thermal resistance from junction-to-air (θ_{JA}). The SOT-23A-5 package has a θ_{JA} of approximately 220°C/Watt when mounted on a single layer FR4 dielectric copper clad PC board.

$$P_{D_{MAX}} = \frac{(T_{J_{MAX}} - T_{A_{MAX}})}{\theta_{JA}}$$

Where all terms are previously defined.

Equation 2.

Equation 1 can be used in conjunction with Equation 2 to ensure regulator thermal operation is within limits. For example:

Given:

$$V_{IN_{MAX}} = 3.0V \pm 10\%$$

$$V_{OUT_{MIN}} = 2.7V \pm 0.5V$$

$$I_{LOAD} = 98mA$$

$$T_{AMAX} = 55^\circ C$$

- Find:
1. Actual power dissipation
 2. Maximum allowable dissipation

Actual power dissipation:

$$\begin{aligned} P_D &\approx (V_{IN_{MAX}} - V_{OUT_{MIN}})I_{LOAD_{MAX}} \\ &= [(3.0 \times 1.1) - (2.7 \times .995)]98 \times 10^{-3} \\ &= 60mW \end{aligned}$$

Maximum allowable power dissipation:

$$\begin{aligned} P_{D_{MAX}} &= \frac{(T_{J_{MAX}} - T_{A_{MAX}})}{\theta_{JA}} \\ &= \frac{(125 - 55)}{220} \\ &= 318mW \end{aligned}$$

In this example, the TC1015 dissipates a maximum of only 60mW; far below the allowable limit of 318mW. In a similar manner, Equation 1 and Equation 2 can be used to calculate maximum current and/or input voltage limits. For example, the maximum allowable V_{IN} is found by substituting the maximum allowable power dissipation of 318mW into Equation 1, from which $V_{IN_{MAX}} = 5.9V$.

Layout Considerations

The primary path of heat conduction out of the package is via the package leads. Therefore, layouts having a ground plane, wide traces at the pads, and wide power supply bus lines combine to lower θ_{JA} and, therefore, increase the maximum allowable power dissipation limit.

100mA CMOS LDO WITH SHUTDOWN AND REFERENCE BYPASS

PRELIMINARY INFORMATION

TC1015

MARKING

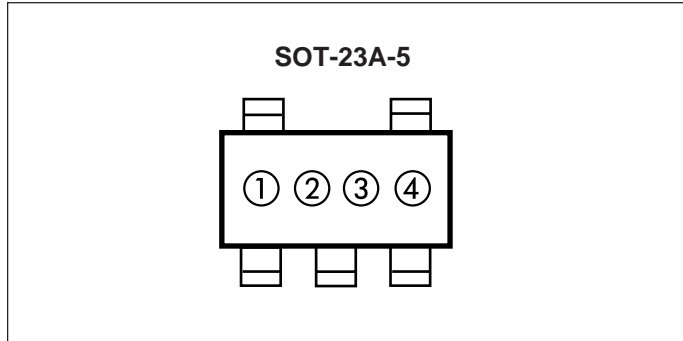

① & ② = part number code + temperature range and voltage

TC1015 (V)	Code
2.5	B1
2.7	B2
3.0	B3
3.3	B5
5.0	B7

③ represents year and quarter code

④ represents lot ID number

PACKAGE DIMENSIONS

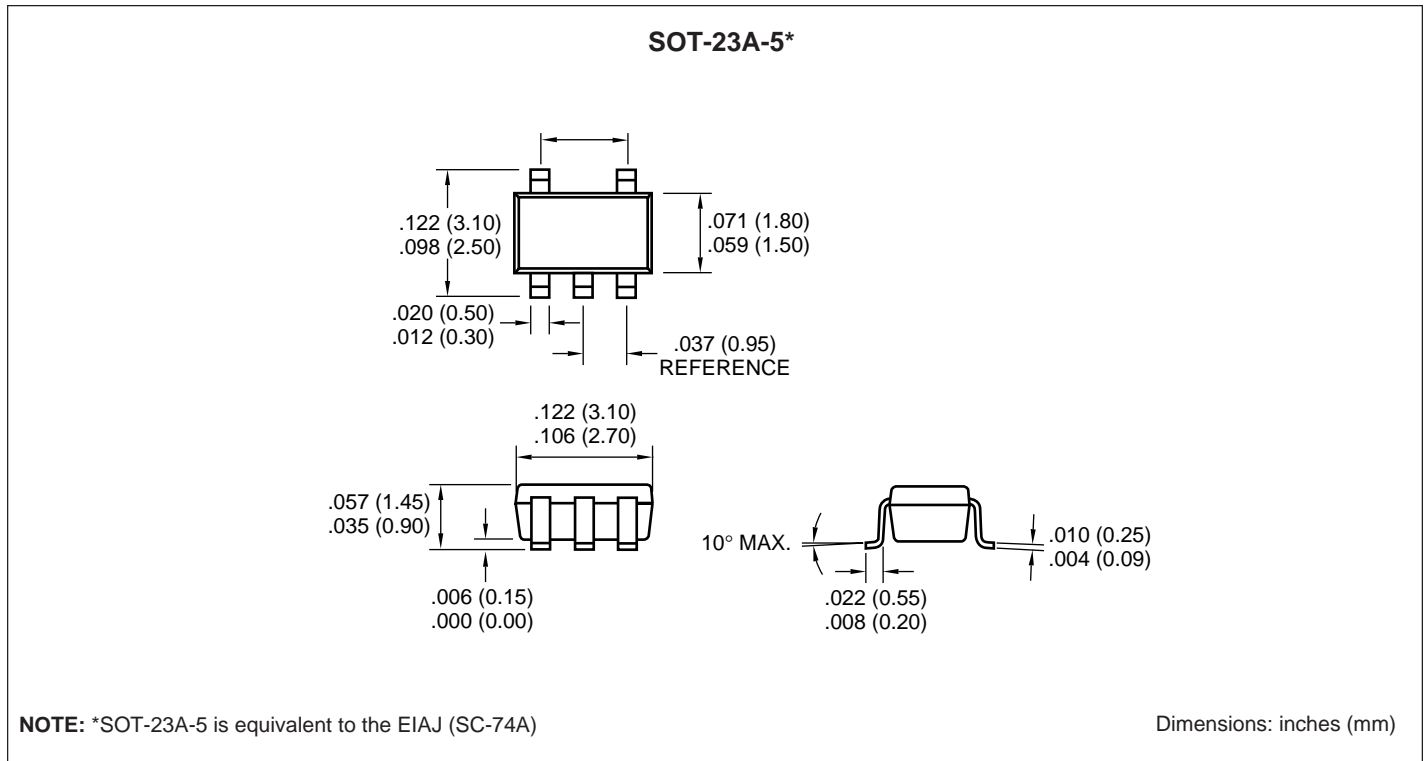

Sales Offices

TelCom Semiconductor
 1300 Terra Bella Avenue
 P.O. Box 7267
 Mountain View, CA 94039-7267
 TEL: 415-968-9241
 FAX: 415-967-1590
 E-Mail: liter@c2smtp.telcom-semi.com

TelCom Semiconductor
 Austin Product Center
 9101 Burnet Rd. Suite 214
 Austin, TX 78758
 TEL: 512-873-7100
 FAX: 512-873-8236

TelCom Semiconductor H.K. Ltd.
 10 Sam Chuk Street, 6/F
 San Po Kong
 Kowloon
 Hong Kong
 TEL: 852-2324-0122
 FAX: 852-2354-9957