

FM803

3-Pin μ C Supervisor Device

General Description

The FM803 is a supervisory device designed to monitor power supply or other system voltage. FM803 generates a reset pulse whenever the voltage being monitored is out of tolerance. Once asserted, the reset pulse is guaranteed to be valid for a minimum of 140ms (256ms typical). The reset output of FM803 is of active low Open-Drain type and has an internal pull-up resistor.

Several threshold voltages are offered to accommodate 5.0V, 3.3V, 3.0V and 2.7V system voltages.

These devices are offered in space saving 3-pin SOT23 and SC70 packages.

Features

- Automatic reset generation on power-up
- Minimum 140 ms reset pulse
- Internal 5k Ω pull-up resistor
- Other reset pulse choices available: 32 - 256 ms
- Operating temperature
 - 40°C to + 105°C (SOT-23)
 - 40°C to +85°C (SC70)
- Choice of Reset Thresholds: 4.63V, 4.38V, 4.00V, 3.08V, 2.93V, 2.63V
- SOT23-3 and SC70-3 Packages

Typical Operating Circuit

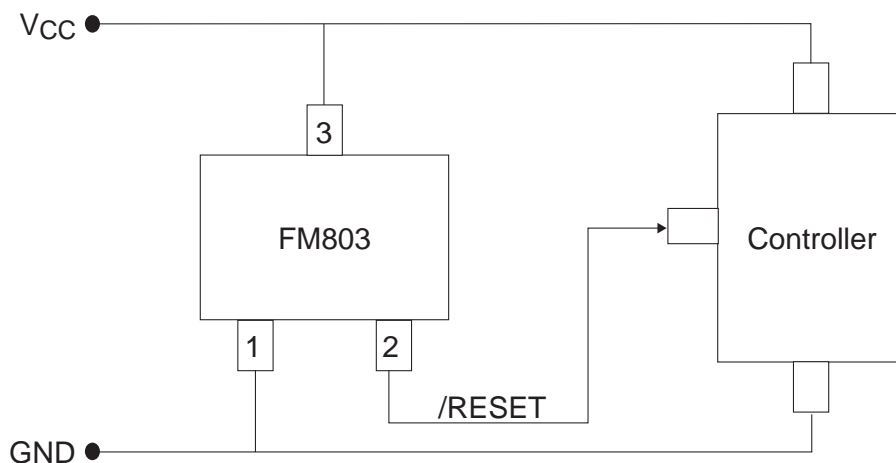

Connection Diagram

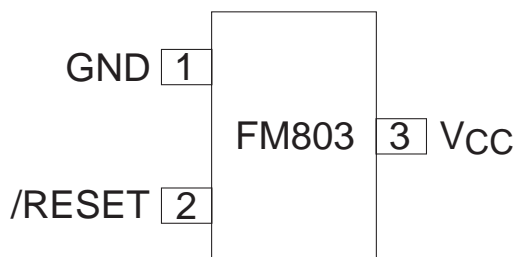

SC70-3 & SOT23-3 Packages

Absolute Maximum Ratings

Voltage on any terminal relative to GND

V_{CC} /RESET -0.3V to +6.0V

Input Current 20mA

Output Current: /RESET 20mA

Rate of Rise of V_{CC} 100V/ μ s

Continuous Power Dissipation ($T_A = +70^\circ\text{C}$)
SOT23-3 (derate 4mW/ $^\circ\text{C}$ above $+70^\circ\text{C}$) 320mW

Operating Temperature Range -40 $^\circ\text{C}$ to +105 $^\circ\text{C}$

Storage Temperature Range -65 $^\circ\text{C}$ to +150 $^\circ\text{C}$

Lead Temperature (soldering, 10s) +300 $^\circ\text{C}$

These are stress ratings only, and functional operation is not implied for these levels or beyond. Exposure to Absolute Maximum Rating conditions for extended periods may affect device reliability.

Electrical Characteristics SOT-23 Package ($T_A = 25^\circ\text{C}$ unless otherwise noted)

V_{CC} = full range, as noted under conditions. See Note 1.

Parameter	Symbol	Conditions	Min	Typ (Note 2)	Max	Units
Operating Voltage	V_{CC}	$T_A = -40^\circ\text{C}$ to $+105^\circ\text{C}$	1.1		5.5	V
Supply Current	I_{CC}	$T_A = -40^\circ\text{C}$ to $+105^\circ\text{C}$, $V_{CC} < 5.5\text{V}$ FM803J/L/M		5	10	μA
		$T_A = -40^\circ\text{C}$ to $+105^\circ\text{C}$, $V_{CC} < 3.6\text{V}$ FM803R/S/T		3	6	
Reset Threshold	V_{TH}	FM803L $T_A = -40^\circ\text{C}$ to $+105^\circ\text{C}$	4.40	4.63	4.86	V
		FM803M $T_A = -40^\circ\text{C}$ to $+105^\circ\text{C}$	4.18	4.38	4.52	
		FM803J $T_A = -40^\circ\text{C}$ to $+105^\circ\text{C}$	3.90	4.00	4.18	
		FM803T $T_A = -40^\circ\text{C}$ to $+105^\circ\text{C}$	2.97	3.08	3.19	
		FM803S $T_A = -40^\circ\text{C}$ to $+105^\circ\text{C}$	2.79	2.93	3.00	
		FM803R $T_A = -40^\circ\text{C}$ to $+105^\circ\text{C}$	2.49	2.63	2.70	
Reset Threshold Tempco				30		ppm/ $^\circ\text{C}$
V_{CC} to Reset Delay		$V_{CC} = V_{TH}$ to $(V_{TH} - 100\text{mV})$		10		μs
Reset Active Timeout Period		$T_A = -40^\circ\text{C}$ to $+105^\circ\text{C}$	140	256	560	ms
FM803 Output Low	V_{OL}	$V_{CC} = V_{TH}(\text{min})$, $I_{SINK} = 1.2\text{mA}$, FM803R/S/T			0.3	V
		$V_{CC} = V_{TH}(\text{min})$, $I_{SINK} = 3.2\text{mA}$, FM803J/L/M			0.4	
		$V_{CC} < 1.0\text{V}$, $I_{SINK} = 50\mu\text{A}$			0.3	
Open-Drain Output Leakage Current		$V_{CC} > V_{TH}(\text{max})$, $I_{RESET} = 1$	$0.8V_{CC}$		1	μA

Note 1: Testing in production is 25 $^\circ\text{C}$ only. Limits over temperature are guaranteed by design.

Note 2: Typical values are at 25 $^\circ\text{C}$.

Absolute Maximum Ratings

Voltage on any terminal relative to GND		Rate of Rise of V_{CC}	100V/ μ s
V_{CC}	-0.3V to +6.0V	Continuous Power Dissipation ($T_A = +70^\circ\text{C}$)	174mW
/RESET	-0.3V to ($V_{CC} + 0.3$ V)	SC70-3	
Input Current	20mA	Operating Temperature Range	-40°C to +85°C
Output Current: /RESET	20mA	Storage Temperature Range	-65°C to +150°C
		Lead Temperature (soldering, 10s)	+300°C

These are stress ratings only, and functional operation is not implied for these levels or beyond. Exposure to Absolute Maximum Rating conditions for extended periods may affect device reliability.

Electrical Characteristics SC70 Package ($T_A = 25^\circ\text{C}$ unless otherwise noted)

V_{CC} = full range, as noted under conditions. See Note 1.

Parameter	Symbol	Conditions	Min	Typ (Note 2)	Max	Units
Operating Voltage	V_{CC}	$T_A = 0^\circ\text{C}$ to $+70^\circ\text{C}$	1.4		5.5	V
		$T_A = -40^\circ\text{C}$ to $+85^\circ\text{C}$	1.6		5.5	
Supply Current	I_{CC}	$T_A = -40^\circ\text{C}$ to $+85^\circ\text{C}$, $V_{CC} < 5.5$ V FM803J/L/M		9	15	μ A
		$T_A = -40^\circ\text{C}$ to $+85^\circ\text{C}$, $V_{CC} < 3.6$ V FM803R/S/T		6	10	
Reset Threshold	V_{TH}	FM803L $T_A = -40^\circ\text{C}$ to $+85^\circ\text{C}$	4.40	4.63	4.86	V
		FM803M $T_A = -40^\circ\text{C}$ to $+85^\circ\text{C}$	4.18	4.38	4.52	
		FM803J $T_A = -40^\circ\text{C}$ to $+85^\circ\text{C}$	3.90	4.00	4.18	
		FM803T $T_A = -40^\circ\text{C}$ to $+85^\circ\text{C}$	2.97	3.08	3.19	
		FM803S $T_A = -40^\circ\text{C}$ to $+85^\circ\text{C}$	2.79	2.93	3.00	
		FM803R $T_A = -40^\circ\text{C}$ to $+85^\circ\text{C}$	2.49	2.63	2.70	
Reset Threshold Tempco				30		ppm/ $^\circ\text{C}$
V_{CC} to Reset Delay (Note 2)		$V_{CC} = V_{TH}$ to ($V_{TH} - 100$ mV)		10		μ s
Reset Active Timeout Period		$T_A = -40^\circ\text{C}$ to $+85^\circ\text{C}$	140	256	560	ms
FM803 Output Low	V_{OL}	$V_{CC} = V_{TH}(\text{min})$, $I_{SINK} = 1.2$ mA, FM803R/S/T			0.35	V
		$V_{CC} = V_{TH}(\text{min})$, $I_{SINK} = 3.2$ mA, FM803J/L/M			0.4	
		$V_{CC} < 1.0$ V, $I_{SINK} = 50$ μ A			0.3	
Open-Drain Output Leakage Current		$V_{CC} > V_{TH}(\text{max})$, /RESET = 1			7	μ A

Note 1: Testing in production is 25°C only. $V_{CC} = 5$ V for FM803L/M/J, $V_{CC} = 3.3$ V for FM803T/S and $V_{CC} = 3$ V for FM803R. Limits over temperature are guaranteed by design.

Note 2: Typical values are at 25°C .

Pin Descriptions

Pin Number	Name	Function
1	GND	GROUND
2	/RESET	/RESET remains LOW while V_{CC} is below V_{TH} , and for at least 140ms after V_{CC} rises above V_{TH} .
3	V_{CC}	

Circuit Timing (Ex: FM803)

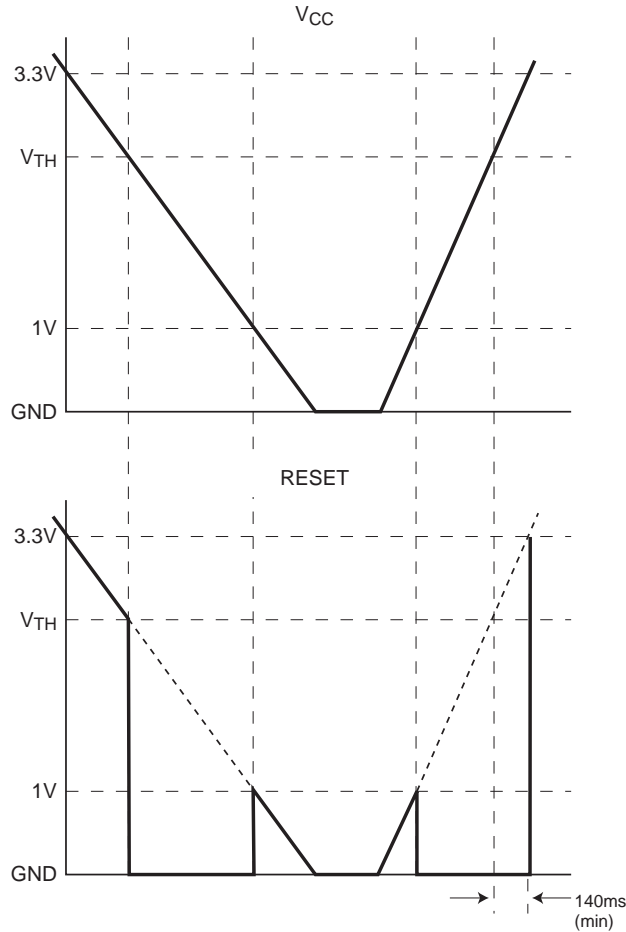

When operating properly with 5V V_{CC} (for example), /RESET will also be about 5V. When V_{CC} starts to fall, /RESET will follow it down as shown. When V_{CC} drops below V_{TH} , /RESET drops to ground ("issues a RESET") and stays there unless V_{CC} also falls below its minimum operating voltage, approx. 1V. At this point, the supervisor loses control, and its output may rise, only to again follow V_{CC} down to the ground.

When V_{CC} begins to rise, /RESET follows it until 1.0V or so is reached, whereupon the device regains control, /RESET is pulled to ground, etc. When V_{CC} rises above V_{TH} , /RESET comes out of RESET 140 ms later.

If it is required that a lower value than GND + 1.0V is needed on RESET signal during $V_{CC} \leq 1V$, a 100K resistor may be used on the device output to GND.

Ordering Information

Part Number	Top Marking	RESET Threshold (V)	Output Type	Package Type	Packing Method
FM803LS3X	03L	4.63	Open-Drain, active LOW	3-Pin, SOT23	3000 units in T&R
FM803MS3X	03M	4.38	Open-Drain, active LOW	3-Pin, SOT23	3000 units in T&R
FM803JS3X	03J	4.00	Open-Drain, active LOW	3-Pin, SOT23	3000 units in T&R
FM803TS3X	03T	3.08	Open-Drain, active LOW	3-Pin, SOT23	3000 units in T&R
FM803SS3X	03S	2.93	Open-Drain, active LOW	3-Pin, SOT23	3000 units in T&R
FM803RS3X	03R	2.63	Open-Drain, active LOW	3-Pin, SOT23	3000 units in T&R
FM803LP3X	QLY	4.63	Open-Drain, active LOW	3-Pin, SC70	3000 units in T&R
FM803MP3X	QMY	4.38	Open-Drain, active LOW	3-Pin, SC70	3000 units in T&R
FM803JP3X	QJY	4.00	Open-Drain, active LOW	3-Pin, SC70	3000 units in T&R
FM803TP3X	QTY	3.08	Open-Drain, active LOW	3-Pin, SC70	3000 units in T&R
FM803SP3X	QSY	2.93	Open-Drain, active LOW	3-Pin, SC70	3000 units in T&R
FM803RP3X	QRY	2.63	Open-Drain, active LOW	3-Pin, SC70	3000 units in T&R

Note 4: Devices listed above feature 250ms typical Reset Pulse width. Consult Fairchild sales for other reset pulse width options.

Physical Dimensions inches (millimeters) unless otherwise noted

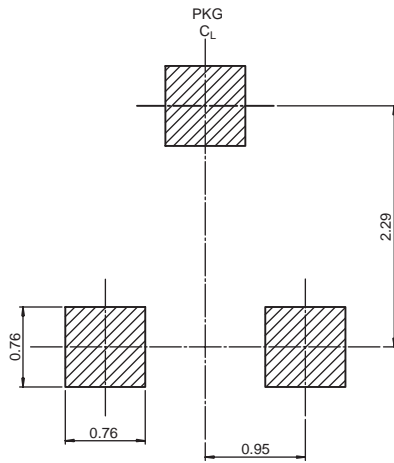
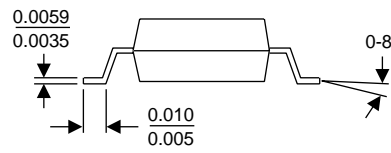
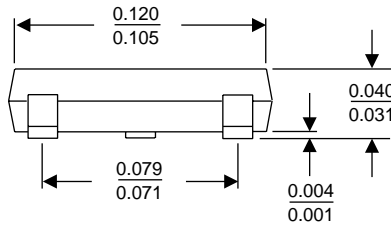
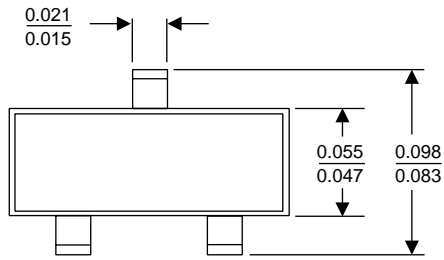

LAND PATTERN RECOMMENDATION

SOT-23 Package Dimensions
FS Pkg Code AU

Physical Dimensions inches (millimeters) unless otherwise noted

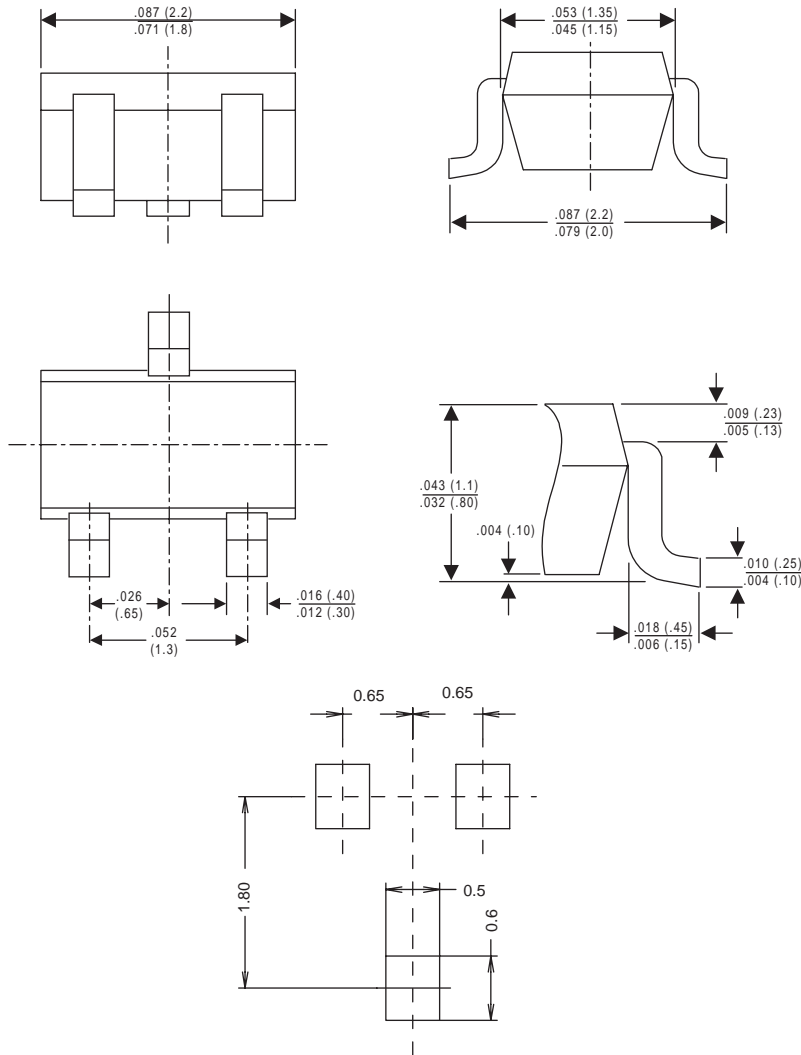

Land Pattern Recommendation

SC70 Package Dimensions

Life Support Policy

Fairchild's products are not authorized for use as critical components in life support devices or systems without the express written approval of the President of Fairchild Semiconductor Corporation. As used herein:

1. Life support devices or systems are devices or systems which, (a) are intended for surgical implant into the body, or (b) support or sustain life, and whose failure to perform, when properly used in accordance with instructions for use provided in the labeling, can be reasonably expected to result in a significant injury to the user.
2. A critical component is any component of a life support device or system whose failure to perform can be reasonably expected to cause the failure of the life support device or system, or to affect its safety or effectiveness.

Fairchild Semiconductor Americas Customer Response Center
Tel: 1-888-522-5372

Fairchild Semiconductor Europe
Fax: +44 (0) 1793-856858
Deutsch Tel: +49 (0) 8141-6102-0
English Tel: +44 (0) 1793-856856
Français Tel: +33 (0) 1-6930-3696
Italiano Tel: +39 (0) 2-249111-1

Fairchild Semiconductor Hong Kong
8/F, Room 808, Empire Centre
68 Mody Road, Tsimshatsui East
Kowloon, Hong Kong
Tel: +852-2722-8338
Fax: +852-2722-8383

Fairchild Semiconductor Japan Ltd.
4F, Natsume Bldg.
2-18-6, Yushima, Bunkyo-ku
Tokyo, 113-0034 Japan
Tel: 81-3-3818-8840
Fax: 81-3-3818-8841

Fairchild does not assume any responsibility for use of any circuitry described, no circuit patent licenses are implied and Fairchild reserves the right at any time without notice to change said circuitry and specifications.