

IRFP250N

N-Channel Power MOSFET 200V, 30A, 0.075Ω

Features

- Ultra Low On-Resistance
 - $r_{DS(ON)} = 0.052\Omega$ (Typ), $V_{GS} = 10V$
- Simulation Models
 - Temperature Compensated PSpice® and SABER® Electrical Models
 - Spice and SABER® Thermal Impedance Models
- Peak Current vs Pulse Width Curve
- UIS Rating Curve

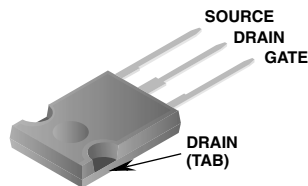

TO-247

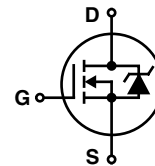

MOSFET Maximum Ratings $T_A = 25^\circ\text{C}$ unless otherwise noted

Symbol	Parameter	Ratings	Units
V_{DSS}	Drain to Source Voltage	200	V
V_{GS}	Gate to Source Voltage	± 20	V
I_D	Drain Current		
	Continuous ($T_C = 25^\circ\text{C}$, $V_{GS} = 10V$)	30	A
	Continuous ($T_C = 100^\circ\text{C}$, $V_{GS} = 10V$)	21	A
	Pulsed	Figure 4	A
E_{AS}	Single Pulse Avalanche Energy (Note 1)	315	mJ
P_D	Power dissipation	214	W
	Derate above 25°C	1.4	W/ $^\circ\text{C}$
T_J, T_{STG}	Operating and Storage Temperature	-55 to 175	$^\circ\text{C}$

Thermal Characteristics

$R_{\theta JC}$	Thermal Resistance Junction to Case TO-247	0.70	$^\circ\text{C}/\text{W}$
$R_{\theta JA}$	Thermal Resistance Junction to Ambient TO-247	40	$^\circ\text{C}/\text{W}$

Package Marking and Ordering Information

Device Marking	Device	Package	Reel Size	Tape Width	Quantity
IRFP250N	IRFP250N	TO-247	Tube	N/A	30

Electrical Characteristics $T_A = 25^\circ\text{C}$ unless otherwise noted

Symbol	Parameter	Test Conditions	Min	Typ	Max	Units
--------	-----------	-----------------	-----	-----	-----	-------

Off Characteristics

B_{VDSS}	Drain to Source Breakdown Voltage	$I_D = 250\mu\text{A}$, $V_{GS} = 0\text{V}$	200	-	-	V
I_{DSS}	Zero Gate Voltage Drain Current	$V_{DS} = 200\text{V}$, $V_{GS} = 0\text{V}$	-	-	25	μA
		$V_{DS} = 160\text{V}$, $T_C = 150^\circ$	-	-	250	
I_{GSS}	Gate to Source Leakage Current	$V_{GS} = \pm 20\text{V}$	-	-	± 100	nA

On Characteristics

$V_{GS(TH)}$	Gate to Source Threshold Voltage	$V_{GS} = V_{DS}$, $I_D = 250\mu\text{A}$	2	-	4	V
$r_{DS(ON)}$	Drain to Source On Resistance	$I_D = 18\text{A}$, $V_{GS} = 10\text{V}$	-	0.052	0.075	Ω
g_{fs}	Forward Transconductance	$V_{DS} = 50\text{V}$, $I_D = 18\text{A}$ (Note 2)	17	-	-	S

Dynamic Characteristics

C_{ISS}	Input Capacitance	$V_{DS} = 25\text{V}$, $V_{GS} = 0\text{V}$, $f = 1\text{MHz}$	-	4023	-	pF	
C_{OSS}	Output Capacitance		-	880	-	pF	
C_{RSS}	Reverse Transfer Capacitance		-	240	-	pF	
$Q_{g(TOT)}$	Total Gate Charge at 20V	$V_{GS} = 0\text{V}$ to 20V	$V_{DD} = 160\text{V}$ $I_D = 18\text{A}$ $I_g = 2.0\text{mA}$	215	280	nC	
$Q_{g(10)}$	Total Gate Charge at 10V	$V_{GS} = 0\text{V}$ to 10V		-	114	140	nC
$Q_{g(TH)}$	Threshold Gate Charge	$V_{GS} = 0\text{V}$ to 2V		-	8	10	nC
Q_{gs}	Gate to Source Gate Charge			-	14	-	nC
Q_{gd}	Gate to Drain "Miller" Charge			-	44	-	nC

Switching Characteristics ($V_{GS} = 10\text{V}$)

t_{ON}	Turn-On Time	$V_{DD} = 100\text{V}$, $I_D = 18\text{A}$ $V_{GS} = 10\text{V}$, $R_{GS} = 3.9\Omega$	-	-	69	ns
$t_{d(ON)}$	Turn-On Delay Time		-	16	-	ns
t_r	Rise Time		-	30	-	ns
$t_{d(OFF)}$	Turn-Off Delay Time		-	78	-	ns
t_f	Fall Time		-	40	-	ns
t_{OFF}	Turn-Off Time		-	-	177	ns

Drain-Source Diode Characteristics

V_{SD}	Source to Drain Diode Voltage	$I_{SD} = 18\text{A}$	-	-	1.3	V
t_{rr}	Reverse Recovery Time	$I_{SD} = 18\text{A}$, $dI_{SD}/dt = 100\text{A}/\mu\text{s}$	-	-	279	ns
Q_{RR}	Reverse Recovered Charge	$I_{SD} = 18\text{A}$, $dI_{SD}/dt = 100\text{A}/\mu\text{s}$	-	-	2000	nC

Notes:

- 1: Starting $T_J = 25^\circ\text{C}$, $L = 1.9\text{mH}$, $I_{AS} = 18\text{A}$.
 2: Pulse width $\leq 300\mu\text{s}$; duty cycle $\leq 2\%$.

Typical Characteristic

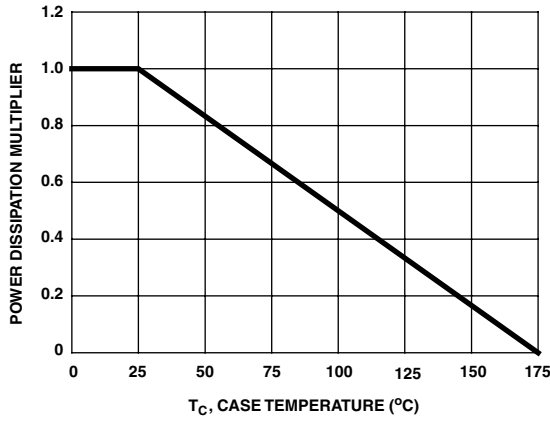

Figure 1. Normalized Power Dissipation vs Ambient Temperature

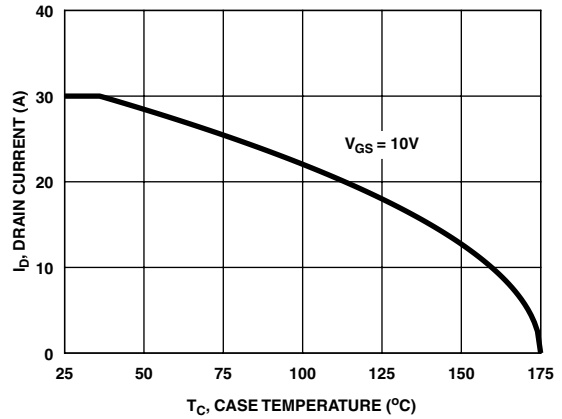

Figure 2. Maximum Continuous Drain Current vs Case Temperature

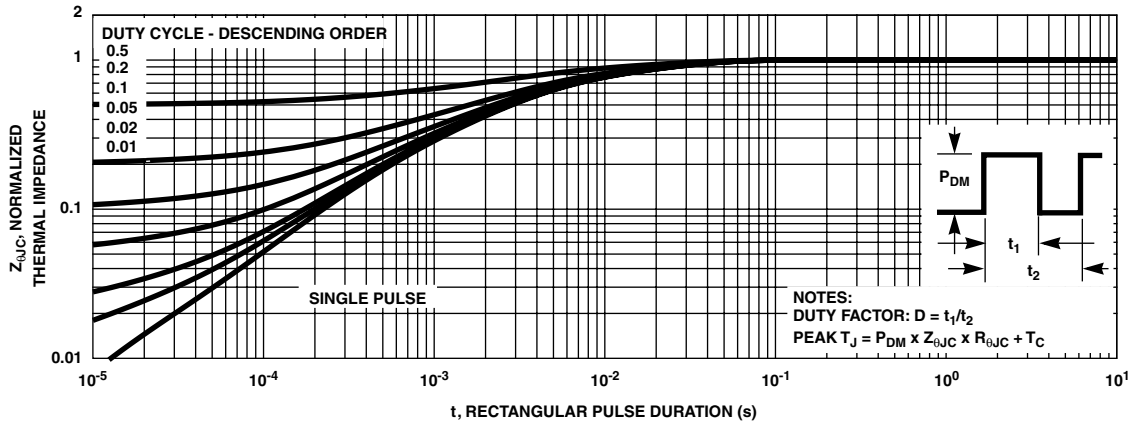

Figure 3. Normalized Maximum Transient Thermal Impedance

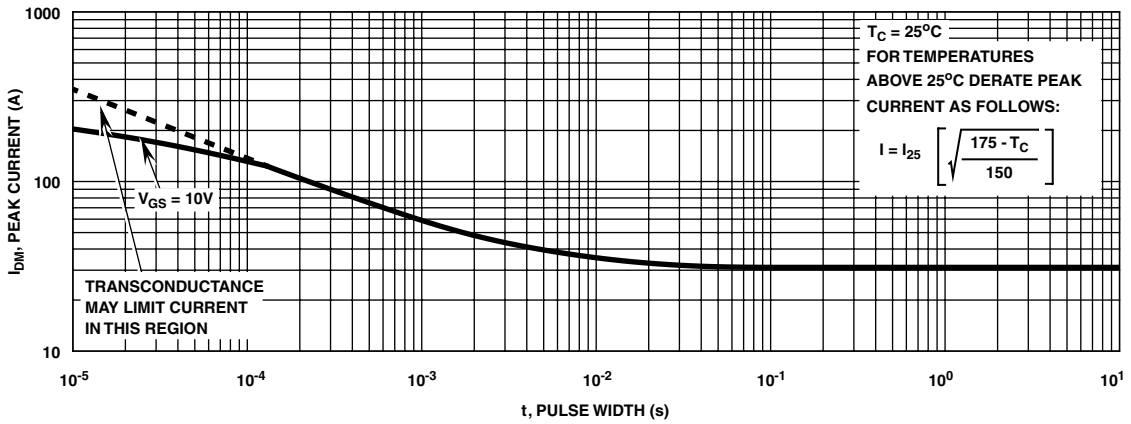

Figure 4. Peak Current Capability

Typical Characteristic (Continued)

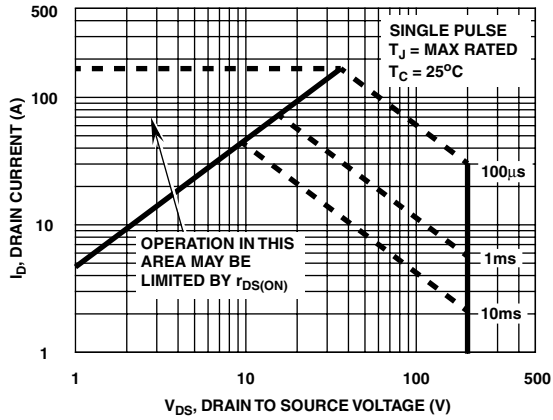

Figure 5. Forward Bias Safe Operating Area

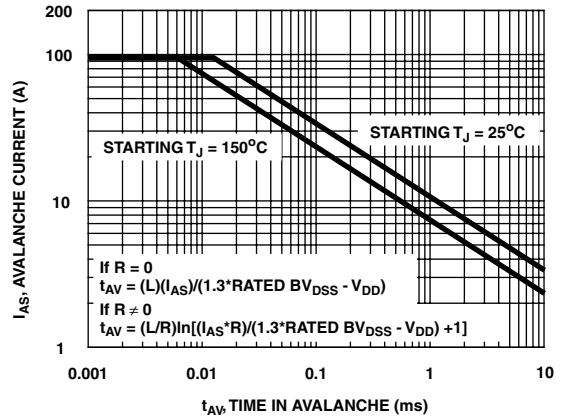

Figure 6. Unclamped Inductive Switching Capability

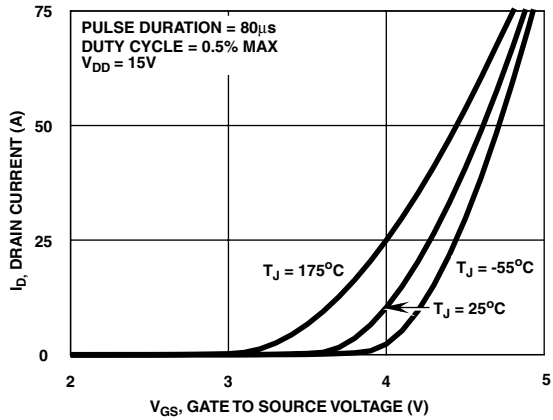

Figure 7. Transfer Characteristics

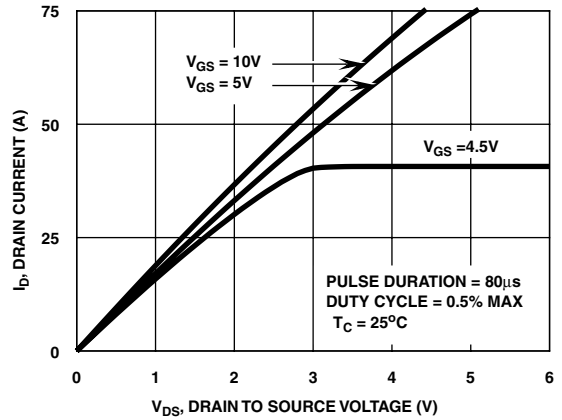

Figure 8. Saturation Characteristics

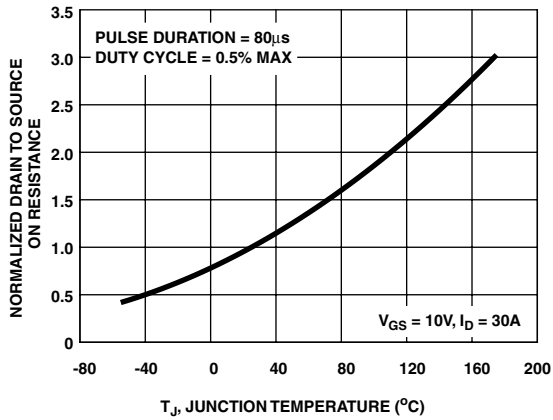

Figure 9. Normalized Drain to Source On Resistance vs Junction Temperature

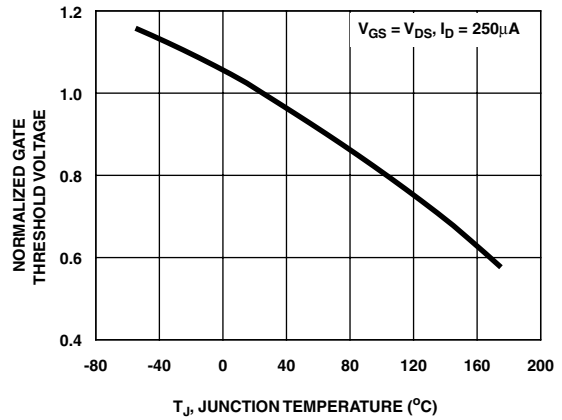

Figure 10. Normalized Gate Threshold Voltage vs Junction Temperature

Typical Characteristic (Continued)

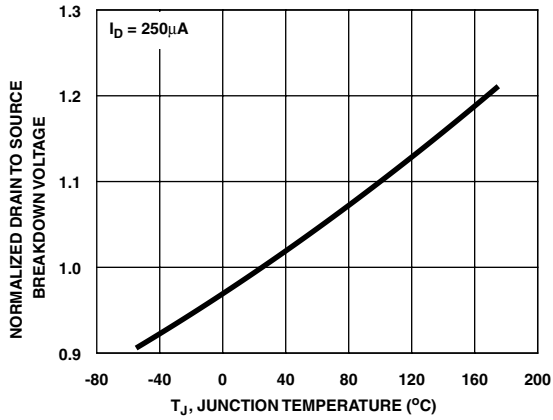

Figure 11. Normalized Drain to Source Breakdown Voltage vs Junction Temperature

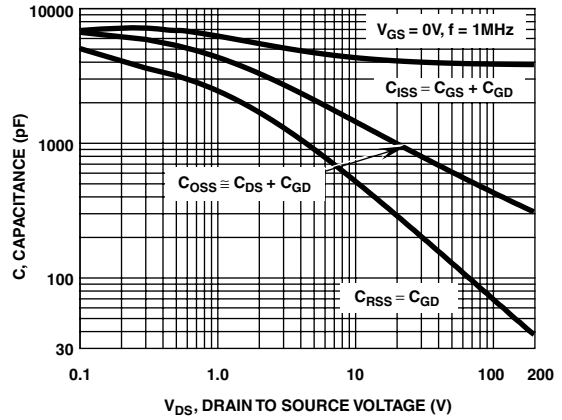

Figure 12. Capacitance vs Drain to Source Voltage

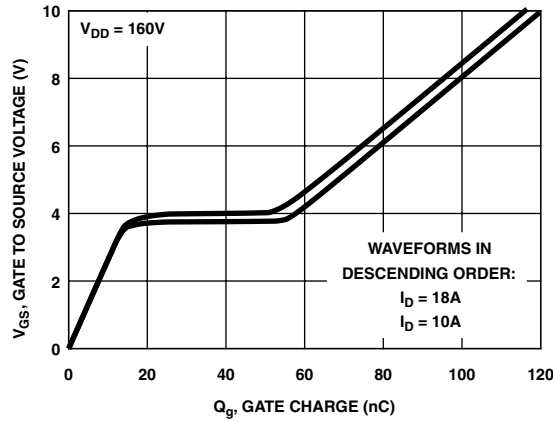

Figure 13. Gate Charge Waveforms for Constant Gate Currents

Test Circuits and Waveforms

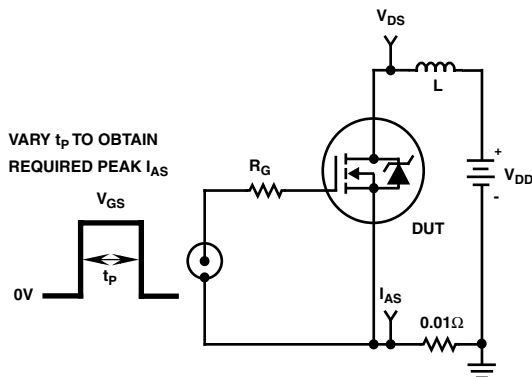

Figure 14. Unclamped Energy Test Circuit

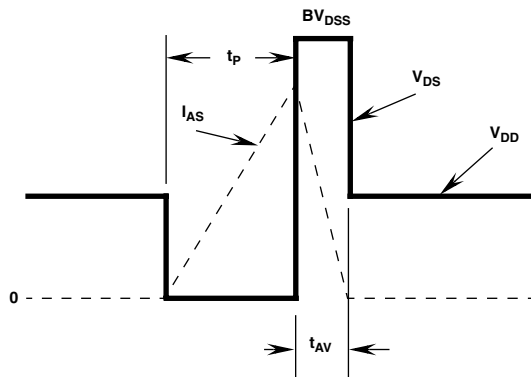

Figure 15. Unclamped Energy Waveforms

Test Circuits and Waveforms (Continued)

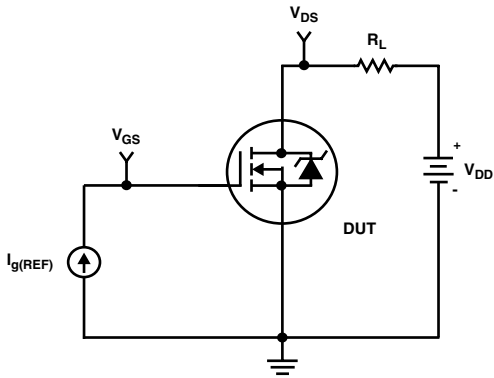

Figure 16. Gate Charge Test Circuit

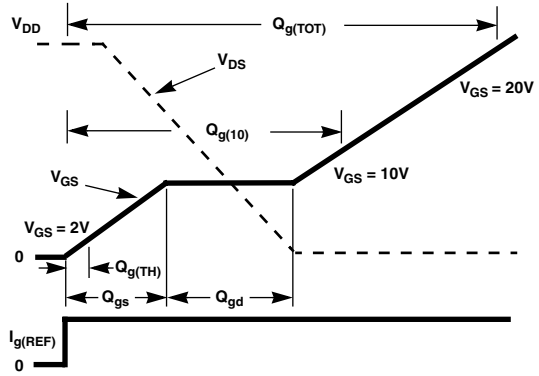

Figure 17. Gate Charge Waveforms

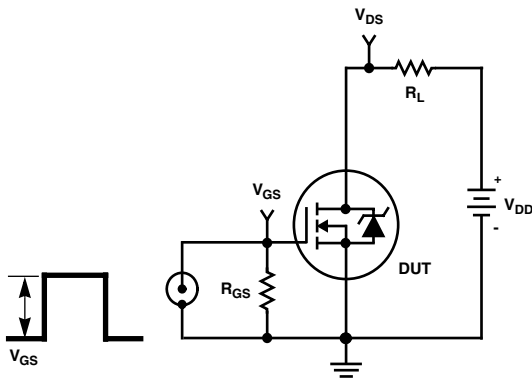

Figure 18. Switching Time Test Circuit

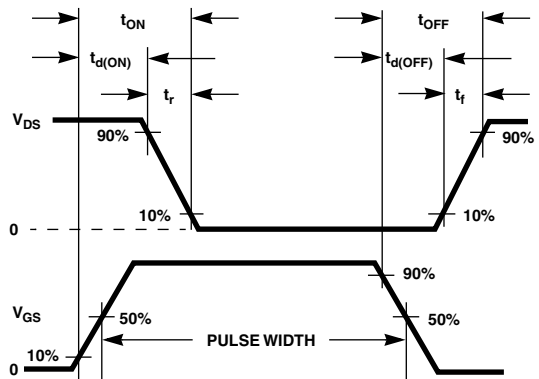

Figure 19. Switching Time Waveforms

SABER Electrical Model

REV May 2001

template IRFP250N n2,n1,n3

electrical n2,n1,n3

{

var i iscl

dp..model dbodymod = (isl = 2.8e-12, rs = 3.0e-3, xti = 5.5, trs1 = 3.5e-3, trs2 = 1.0e-5, cjo = 2.55e-9, tt = 1.52e-7, m = 0.42)

dp..model dbreakmod = (rs = 1.2, trs1 = 1.0e-3, trs2 = 1.0e-6)

dp..model dplcapmod = (cjo = 4.6e-9, isl = 10e-30, nl=10, m = 0.9)

m..model mmedmod = (type=_n, vto = 3.05, kp = 2.5, is = 1e-30, tox = 1)

m..model mstrongmod = (type=_n, vto = 3.55, kp = 100, is = 1e-30, tox = 1)

m..model mweakmod = (type=_n, vto = 2.69, kp = 0.05, is = 1e-30, tox = 1, rs=0.1)

sw_vcsp..model s1amod = (ron = 1e-5, roff = 0.1, von = -5.5, voff = -4.5)

sw_vcsp..model s1bmod = (ron = 1e-5, roff = 0.1, von = -4.5, voff = -5.5)

sw_vcsp..model s2amod = (ron = 1e-5, roff = 0.1, von = -0.3, voff = 0.4)

sw_vcsp..model s2bmod = (ron = 1e-5, roff = 0.1, von = 0.4, voff = -0.3)

c.ca n12 n8 = 6.6e-9

c.cb n15 n14 = 6.5e-9

c.cin n6 n8 = 3.8e-9

dp.dbody n7 n5 = model=dbodymod

dp.dbreak n5 n11 = model=dbreakmod

dp.dplcap n10 n5 = model=dplcapmod

i.it n8 n17 = 1

l.ldrain n2 n5 = 1.00e-9

l.lgate n1 n9 = 8.05e-9

l.lsource n3 n7 = 5.80e-9

m.mmed n16 n6 n8 n8 = model=mmedmod, l=1u, w=1u

m.mstrong n16 n6 n8 n8 = model=mstrongmod, l=1u, w=1u

m.mweak n16 n21 n8 n8 = model=mweakmod, l=1u, w=1u

res.rbreak n17 n18 = 1, tc1 = 1.27e-3, tc2 = 1.00e-6

res.rdrain n50 n16 = 5.0e-2, tc1 = 9.9e-3, tc2 = 3.6e-5

res.rgate n9 n20 = 0.77

res.rldrain n2 n5 = 10

res.rlgate n1 n9 = 80.5

res.rlsource n3 n7 = 58

res.rslc1 n5 n51 = 1e-6, tc1 = 3e-3, tc2 = -1.0e-6

res.rslc2 n5 n50 = 1e3

res.rsource n8 n7 = 1.8e-3, tc1 = 1.0e-3, tc2 = 1e-6

res.rvtemp n18 n19 = 1, tc1 = -2.8e-3, tc2 = 1.70e-6

res.rvthres n22 n8 = 1, tc1 = -2.9e-3, tc2 = 1.1e-5

spe.ebreak n11 n7 n17 n18 = 221

spe.eds n14 n8 n5 n8 = 1

spe.egs n13 n8 n6 n8 = 1

spe.esg n6 n10 n6 n8 = 1

spe.evtemp n20 n6 n18 n22 = 1

spe.evthres n6 n21 n19 n8 = 1

sw_vcsp.s1a n6 n12 n13 n8 = model=s1amod

sw_vcsp.s1b n13 n12 n13 n8 = model=s1bmod

sw_vcsp.s2a n6 n15 n14 n13 = model=s2amod

sw_vcsp.s2b n13 n15 n14 n13 = model=s2bmod

v.vbat n22 n19 = dc=1

equations {

i (n51->n50) +=iscl

iscl: v(n51,n50) = ((v(n5,n51))/(1e-9+abs(v(n5,n51))))*((abs(v(n5,n51))*1e6*100)** 2.5)

}

}

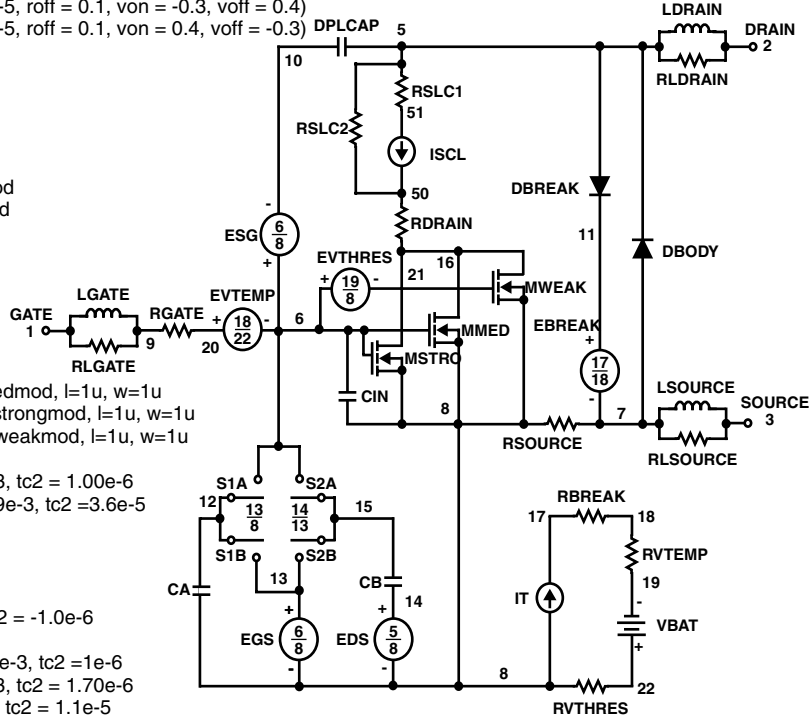

SPICE Thermal Model

REV May 2001

IRFP250N

CTHERM1 th 6 6.45e-3
 CTHERM2 6 5 3.00e-2
 CTHERM3 5 4 1.40e-2
 CTHERM4 4 3 1.65e-2
 CTHERM5 3 2 4.85e-2
 CTHERM6 2 tl 1.00e-1

RTHERM1 th 6 3.24e-3
 RTHERM2 6 5 8.08e-3
 RTHERM3 5 4 2.28e-2
 RTHERM4 4 3 1.00e-1
 RTHERM5 3 2 1.10e-1
 RTHERM6 2 tl 1.40e-1

SABER Thermal Model

SABER thermal model IRFP250N

```

template thermal_model th tl
thermal_c th, tl
{
    ctherm.ctherm1 th 6 = 6.45e-3
    ctherm.ctherm2 6 5 = 3.00e-2
    ctherm.ctherm3 5 4 = 1.40e-2
    ctherm.ctherm4 4 3 = 1.65e-2
    ctherm.ctherm5 3 2 = 4.85e-2
    ctherm.ctherm6 2 tl = 1.00e-1

    rtherm.rtherm1 th 6 = 3.24e-3
    rtherm.rtherm2 6 5 = 8.08e-3
    rtherm.rtherm3 5 4 = 2.28e-2
    rtherm.rtherm4 4 3 = 1.00e-1
    rtherm.rtherm5 3 2 = 1.10e-1
    rtherm.rtherm6 2 tl = 1.40e-1
}
    
```

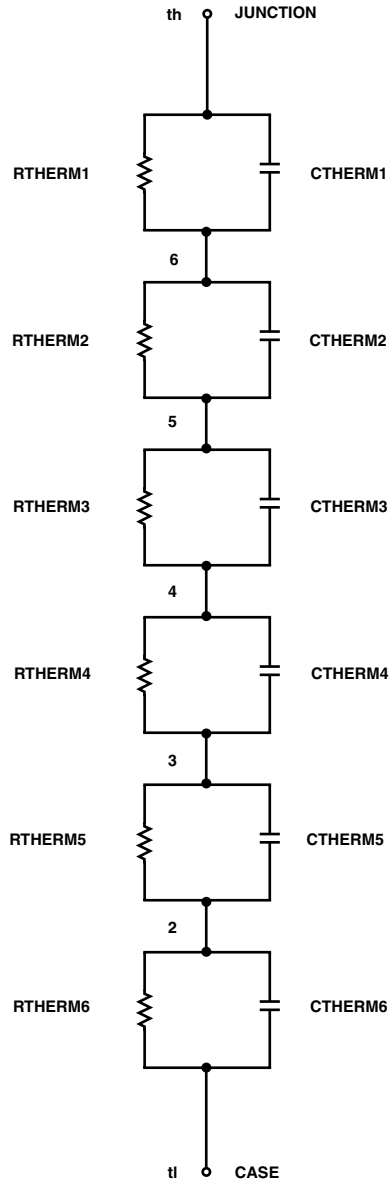

TRADEMARKS

The following are registered and unregistered trademarks Fairchild Semiconductor owns or is authorized to use and is not intended to be an exhaustive list of all such trademarks.

ACE _x TM	FAST [®]	OPTOLOGIC TM	SMART START TM	VCX TM
Bottomless TM	FAST _r TM	OPTOPLANAR TM	STAR*POWER TM	
CoolFET TM	FRFET TM	PACMAN TM	Stealth TM	
CROSSVOLT TM	GlobalOptoisolator TM	POP TM	SuperSOT TM -3	
DenseTrench TM	GTO TM	Power247 TM	SuperSOT TM -6	
DOMET TM	HiSeC TM	PowerTrench [®]	SuperSOT TM -8	
EcoSPARK TM	ISOPLANAR TM	QFET TM	SyncFET TM	
E ² CMOS TM	LittleFET TM	QS TM	TinyLogic TM	
EnSigna TM	MicroFET TM	QT Optoelectronics TM	TruTranslation TM	
FACT TM	MicroPak TM	Quiet Series TM	UHC TM	
FACT Quiet Series TM	MICROWIRE TM	SILENT SWITCHER [®]	UltraFET [®]	

STAR*POWER is used under license

DISCLAIMER

FAIRCHILD SEMICONDUCTOR RESERVES THE RIGHT TO MAKE CHANGES WITHOUT FURTHER NOTICE TO ANY PRODUCTS HEREIN TO IMPROVE RELIABILITY, FUNCTION OR DESIGN. FAIRCHILD DOES NOT ASSUME ANY LIABILITY ARISING OUT OF THE APPLICATION OR USE OF ANY PRODUCT OR CIRCUIT DESCRIBED HEREIN; NEITHER DOES IT CONVEY ANY LICENSE UNDER ITS PATENT RIGHTS, NOR THE RIGHTS OF OTHERS.

LIFE SUPPORT POLICY

FAIRCHILD'S PRODUCTS ARE NOT AUTHORIZED FOR USE AS CRITICAL COMPONENTS IN LIFE SUPPORT DEVICES OR SYSTEMS WITHOUT THE EXPRESS WRITTEN APPROVAL OF FAIRCHILD SEMICONDUCTOR CORPORATION.

As used herein:

1. Life support devices or systems are devices or systems which, (a) are intended for surgical implant into the body, or (b) support or sustain life, or (c) whose failure to perform when properly used in accordance with instructions for use provided in the labeling, can be reasonably expected to result in significant injury to the user.
2. A critical component is any component of a life support device or system whose failure to perform can be reasonably expected to cause the failure of the life support device or system, or to affect its safety or effectiveness.

PRODUCT STATUS DEFINITIONS

Definition of Terms

Datasheet Identification	Product Status	Definition
Advance Information	Formative or In Design	This datasheet contains the design specifications for product development. Specifications may change in any manner without notice.
Preliminary	First Production	This datasheet contains preliminary data, and supplementary data will be published at a later date. Fairchild Semiconductor reserves the right to make changes at any time without notice in order to improve design.
No Identification Needed	Full Production	This datasheet contains final specifications. Fairchild Semiconductor reserves the right to make changes at any time without notice in order to improve design.
Obsolete	Not In Production	This datasheet contains specifications on a product that has been discontinued by Fairchild semiconductor. The datasheet is printed for reference information only.