

MMBD301

PACKAGE
SOT-23
TO-236AB (Low)

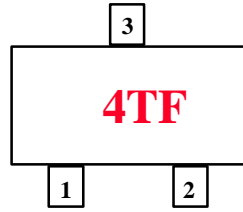

CONNECTION DIAGRAM

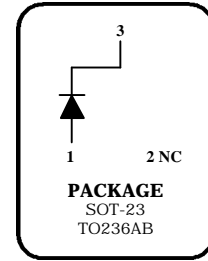

Schottky Barrier Diode

Sourced from Process GD

Absolute Maximum Ratings* TA = 25°C unless otherwise noted

| Sym | Parameter | Value | Units |
|-----------|---|-------------|-------------|
| T_{stg} | Storage Temperature | -55 to +150 | °C |
| T_J | Operating Junction Temperature | -55 to +125 | °C |
| W_{IV} | Working Inverse Voltage | 30 | V |
| P_F | Forward Power Dissipation @ $T_A = 25^\circ\text{C}$ Derate above 25°C | 200 2.0 | mW mW/°C |

*These ratings are limiting values above which the serviceability of any semiconductor device may be impaired

Electrical Characteristics TA = 25°C unless otherwise noted

| SYM | CHARACTERISTICS | MIN | MAX | UNITS | TEST CONDITIONS |
|-------|-------------------|-----|------------|----------|---|
| B_V | Breakdown Voltage | 30 | | V | $I_R = 10 \mu\text{A}$ |
| I_R | Reverse Leakage | | 200 | nA | $V_R = 25 \text{ V}$ |
| V_F | Forward Voltage | | 450 600 | mV mV | $I_F = 1.0 \text{ mA}$ $I_F = 10 \text{ mA}$ |
| C_T | Capacitance | | 1.5 | pF | $V_R = 15 \text{ V}$ $f = 1.0 \text{ MHz}$ |

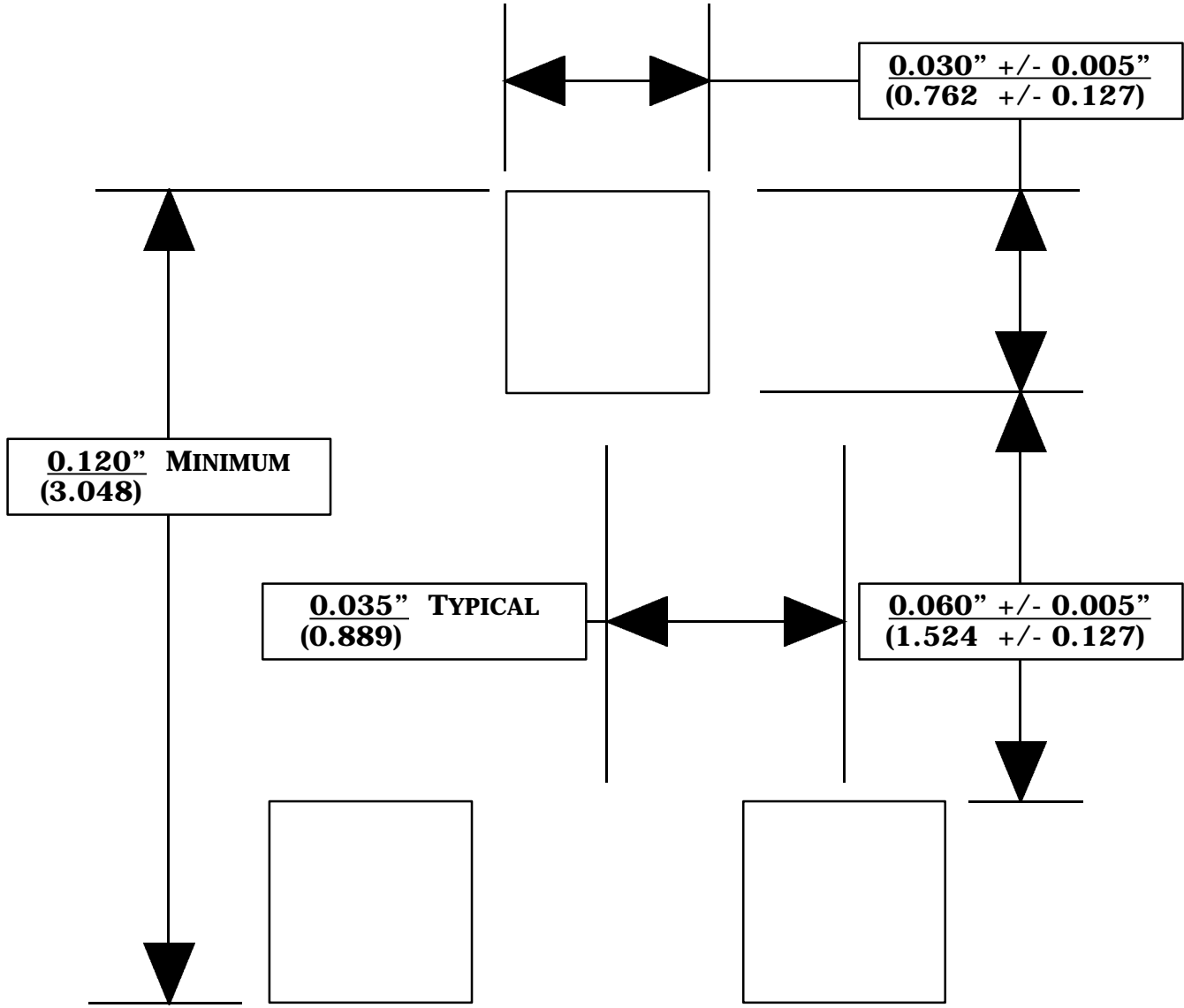

**RECOMMENDED SOLDER PADS
FOR
SOT-23**

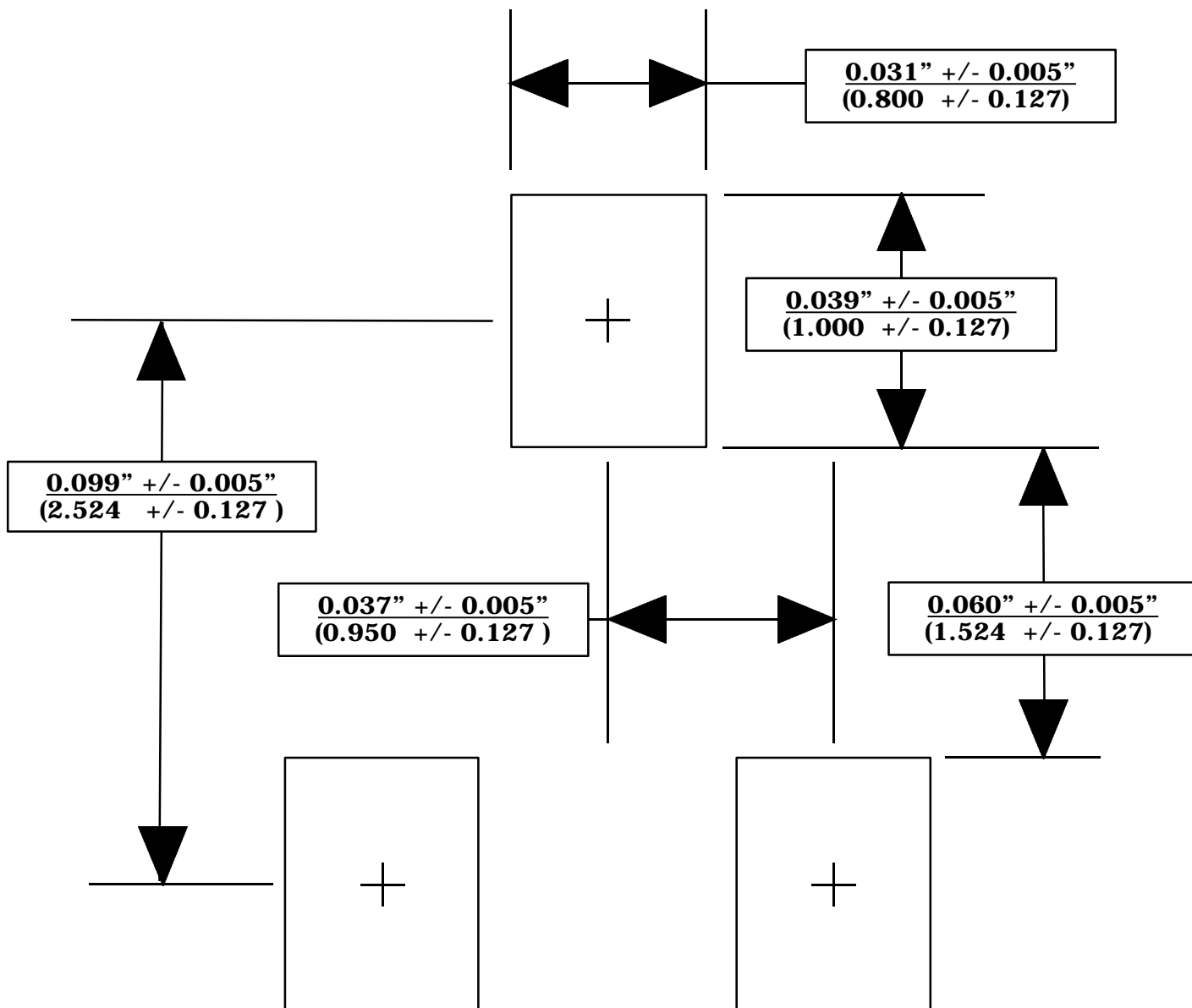

**RECOMMENDED SOLDER PADS
FOR
U.S. & European SOT-23
&
Japanese SC-59**

TRADEMARKS

The following are registered and unregistered trademarks Fairchild Semiconductor owns or is authorized to use and is not intended to be an exhaustive list of all such trademarks.

| | | | |
|-----------------------------------|----------------------------------|----------------------------------|---------------------------|
| ACE _x TM | FAST [®] | OPTOPLANAR TM | SuperSOT TM -3 |
| Bottomless TM | FAST _r TM | PACMAN TM | SuperSOT TM -6 |
| CoolFET TM | FRFET TM | POP TM | SuperSOT TM -8 |
| CROSSVOLT TM | GlobalOptoisolator TM | PowerTrench [®] | SyncFET TM |
| DenseTrench TM | GTO TM | QFET TM | TinyLogic TM |
| DOMET TM | HiSeC TM | QS TM | UHC TM |
| EcoSPARK TM | ISOPLANAR TM | QT Optoelectronics TM | UltraFET [®] |
| E ² CMOS TM | LittleFET TM | Quiet Series TM | VCX TM |
| EnSigna TM | MicroFET TM | SILENT SWITCHER [®] | |
| FACT TM | MICROWIRE TM | SMART START TM | |
| FACT Quiet Series TM | OPTOLOGIC TM | Stealth TM | |

DISCLAIMER

FAIRCHILD SEMICONDUCTOR RESERVES THE RIGHT TO MAKE CHANGES WITHOUT FURTHER NOTICE TO ANY PRODUCTS HEREIN TO IMPROVE RELIABILITY, FUNCTION OR DESIGN. FAIRCHILD DOES NOT ASSUME ANY LIABILITY ARISING OUT OF THE APPLICATION OR USE OF ANY PRODUCT OR CIRCUIT DESCRIBED HEREIN; NEITHER DOES IT CONVEY ANY LICENSE UNDER ITS PATENT RIGHTS, NOR THE RIGHTS OF OTHERS.

LIFE SUPPORT POLICY

FAIRCHILD'S PRODUCTS ARE NOT AUTHORIZED FOR USE AS CRITICAL COMPONENTS IN LIFE SUPPORT DEVICES OR SYSTEMS WITHOUT THE EXPRESS WRITTEN APPROVAL OF FAIRCHILD SEMICONDUCTOR CORPORATION. As used herein:

1. Life support devices or systems are devices or systems which, (a) are intended for surgical implant into the body, or (b) support or sustain life, or (c) whose failure to perform when properly used in accordance with instructions for use provided in the labeling, can be reasonably expected to result in significant injury to the user.
2. A critical component is any component of a life support device or system whose failure to perform can be reasonably expected to cause the failure of the life support device or system, or to affect its safety or effectiveness.

PRODUCT STATUS DEFINITIONS

Definition of Terms

| Datasheet Identification | Product Status | Definition |
|--------------------------|------------------------|---|
| Advance Information | Formative or In Design | This datasheet contains the design specifications for product development. Specifications may change in any manner without notice. |
| Preliminary | First Production | This datasheet contains preliminary data, and supplementary data will be published at a later date. Fairchild Semiconductor reserves the right to make changes at any time without notice in order to improve design. |
| No Identification Needed | Full Production | This datasheet contains final specifications. Fairchild Semiconductor reserves the right to make changes at any time without notice in order to improve design. |
| Obsolete | Not In Production | This datasheet contains specifications on a product that has been discontinued by Fairchild semiconductor. The datasheet is printed for reference information only. |