

MMBF4416

MMBF4416

N-Channel RF Amplifiers

- This device is designed for RF amplifiers.
- Sourced from process 50.

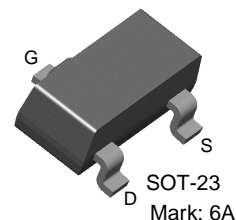

Absolute Maximum Ratings $T_A=25^\circ\text{C}$ unless otherwise noted

Symbol	Parameter	Value	Units
V_{DG}	Drain-Gate Voltage	30	V
V_{GS}	Gate-Source Voltage	-30	V
I_{GF}	Forward Gate Current	10	mA
T_J, T_{STG}	Junction and Storage Temperature Range	- 55 ~ 150	$^\circ\text{C}$

Electrical Characteristics $T_A=25^\circ\text{C}$ unless otherwise noted

Symbol	Parameter	Test Condition	Min.	Typ.	Max.	Units
Off Characteristics						
$V_{(BR)GSS}$	Gate-Source Breakdown Voltage	$V_{DS} = 0, I_G = 1\mu\text{A}$	-30			V
I_{GSS}	Gate Reverse Current	$V_{GS} = -20\text{V}, V_{DS} = 0$ $V_{GS} = -20\text{V}, V_{DS} = 0, T_A = 150^\circ\text{C}$			-1 -200	nA nA
$V_{GS(off)}$	Gate Source Cut-off Voltage	$V_{DS} = 15\text{V}, I_D = 1\text{nA}$	-2.5		-6	V
V_{GS}	Gate Source Voltage	$V_{DS} = 15\text{V}, I_D = 0.5\text{mA}$	-1		-5.5	V
On Characteristics						
I_{DSS}	Zero-Gate Voltage Drain Current	$V_{GS} = 15\text{V}, V_{GS} = 0$	5		15	μA
$V_{GS(f)}$	Gate-Source Forward Voltage	$V_{DS} = 0, I_G = 1\text{mA}$			1	V
Small Signal Characteristics						
$ Y_{fs} $	Forward Transfer Admittance	$V_{DS} = 15\text{V}, V_{GS} = 0, f = 1\text{KHz}$	4500		7500	μmhos
$ Y_{os} $	Output Admittance	$V_{DS} = 15\text{V}, V_{GS} = 0, f = 1\text{KHz}$			50	μmhos
C_{iss}	Input Capacitance	$V_{DS} = 15\text{V}, V_{GS} = 0, f = 1\text{MHz}$			4	pF
C_{rss}	Reverse Transfer Capacitance	$V_{DS} = 15\text{V}, V_{GS} = 0, f = 1\text{MHz}$			0.9	pF
C_{oss}	Output Capacitance	$V_{DS} = 15\text{V}, V_{GS} = 0, f = 1\text{MHz}$			2	pF
Functional Characteristics						
NF	Noise Figure	$V_{DS} = 15\text{V}, I_D = 5\text{mA}, R_g = 100\Omega,$ $f = 100\text{MHz}$			2	dB
G_{ps}	Common Source Power Gain	$V_{DS} = 15\text{V}, I_D = 5\text{mA}, R_g = 100\Omega,$ $f = 100\text{MHz}$	18			dB

Thermal Characteristics $T_A=25^\circ\text{C}$ unless otherwise noted

Symbol	Parameter	Max.	Units
P_D	Total Device Dissipation Derate above 25°C	225 1.8	mW mW/ $^\circ\text{C}$
$R_{\theta JA}$	Thermal Resistance, Junction to Ambient	556	$^\circ\text{C}/\text{W}$

* Device mounted on FR-4 PCB $1.6'' \times 1.6'' \times 0.06''$.

Package Dimensions

SOT-23

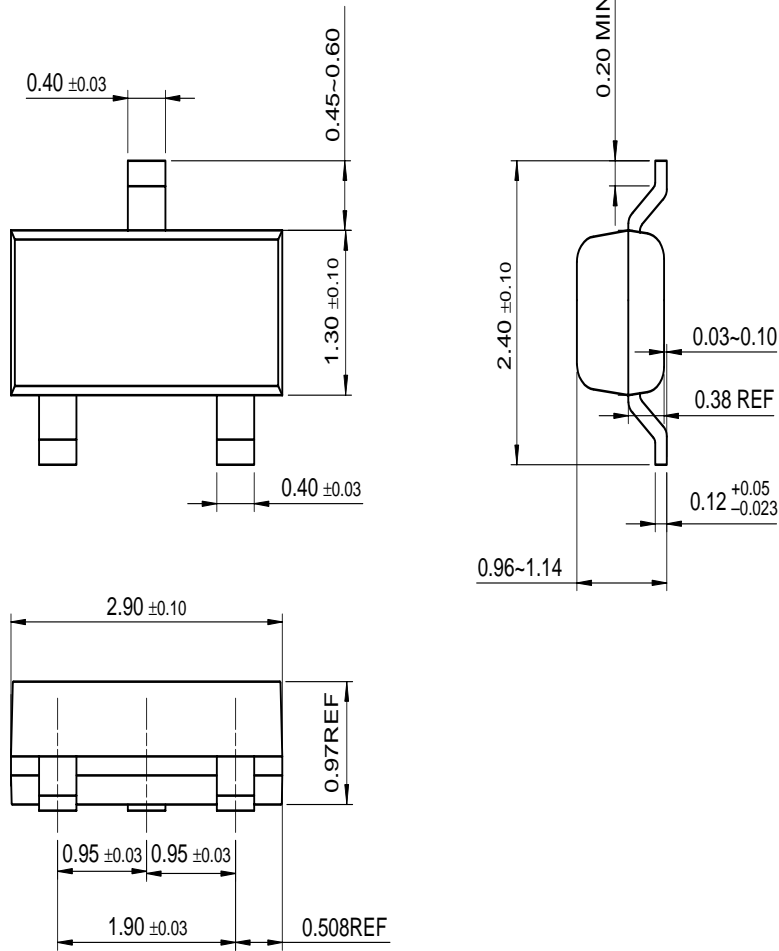

Dimensions in Millimeters

TRADEMARKS

The following are registered and unregistered trademarks Fairchild Semiconductor owns or is authorized to use and is not intended to be an exhaustive list of all such trademarks.

ACE ^x ™	FAST ^r ™	OPTOLOGIC®	SMART START™	VCX™
Bottomless™	FRFET™	OPTOPLANAR™	SPM™	
CoolFET™	GlobalOptoisolator™	PACMAN™	Stealth™	
CROSSVOLT™	GTO™	POP™	SuperSOT™-3	
DOME™	HiSeC™	Power247™	SuperSOT™-6	
EcoSPARK™	I ² C™	PowerTrench®	SuperSOT™-8	
E ² CMOS™	ISOPLANAR™	QFET™	SyncFET™	
EnSigna™	LittleFET™	QS™	TinyLogic™	
FACT™	MicroFET™	QT Optoelectronics™	TruTranslation™	
FACT Quiet series™	MicroPak™	Quiet Series™	UHC™	
FAST®	MICROWIRE™	SLIENT SWITCHER®	UltraFET®	

DISCLAIMER

FAIRCHILD SEMICONDUCTOR RESERVES THE RIGHT TO MAKE CHANGES WITHOUT FURTHER NOTICE TO ANY PRODUCTS HEREIN TO IMPROVE RELIABILITY, FUNCTION OR DESIGN. FAIRCHILD DOES NOT ASSUME ANY LIABILITY ARISING OUT OF THE APPLICATION OR USE OF ANY PRODUCT OR CIRCUIT DESCRIBED HEREIN; NEITHER DOES IT CONVEY ANY LICENSE UNDER ITS PATENT RIGHTS, NOR THE RIGHTS OF OTHERS.

LIFE SUPPORT POLICY

FAIRCHILD'S PRODUCTS ARE NOT AUTHORIZED FOR USE AS CRITICAL COMPONENTS IN LIFE SUPPORT DEVICES OR SYSTEMS WITHOUT THE EXPRESS WRITTEN APPROVAL OF FAIRCHILD SEMICONDUCTOR CORPORATION.

As used herein:

1. Life support devices or systems are devices or systems which, (a) are intended for surgical implant into the body, or (b) support or sustain life, or (c) whose failure to perform when properly used in accordance with instructions for use provided in the labeling, can be reasonably expected to result in significant injury to the user.
2. A critical component is any component of a life support device or system whose failure to perform can be reasonably expected to cause the failure of the life support device or system, or to affect its safety or effectiveness.

PRODUCT STATUS DEFINITIONS

Definition of Terms

Datasheet Identification	Product Status	Definition
Advance Information	Formative or In Design	This datasheet contains the design specifications for product development. Specifications may change in any manner without notice.
Preliminary	First Production	This datasheet contains preliminary data, and supplementary data will be published at a later date. Fairchild Semiconductor reserves the right to make changes at any time without notice in order to improve design.
No Identification Needed	Full Production	This datasheet contains final specifications. Fairchild Semiconductor reserves the right to make changes at any time without notice in order to improve design.
Obsolete	Not In Production	This datasheet contains specifications on a product that has been discontinued by Fairchild semiconductor. The datasheet is printed for reference information only.