

PHEMT GaAs IC High Power SP3T Switch DC–2 GHz



AS202-321

Features

- Positive Low Voltage Control (0/2.75 V Operation)
- Low Insertion Loss (< 0.6 dB @ 2 GHz)
- High Isolation (30 dB at 1 and 2 GHz)
- Excellent Harmonics Performance (65 dBc @ 2.75 V 1 GHz $P_{IN} = 34$ dBm)
- Miniature MLP-12 Plastic Package
- PHEMT Process

Description

The AS202-321 is a PHEMT GaAs IC SP3T antenna switch operating in the 900 MHz and 1800 MHz frequency bands. Switching between the antenna and T_X/R_X ports is accomplished with 3 control inputs. When the control inputs are driven with the appropriate voltages, a low insertion loss path is provided from an antenna port to an R_X or T_X port, while the other ports have high attenuation.

MLP-12

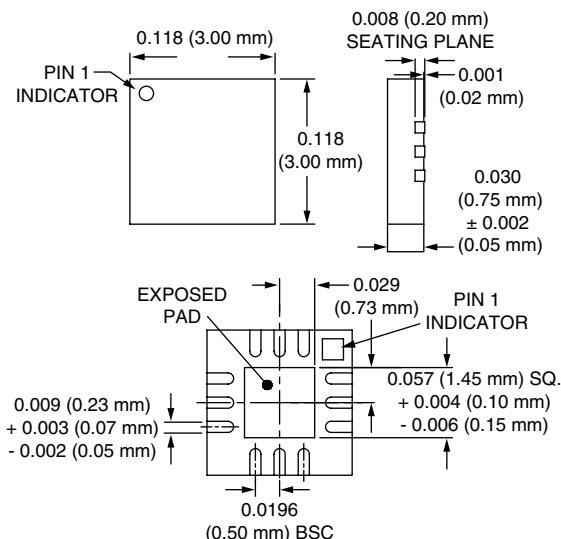

Electrical Specifications at 25°C (0, +2.75 V)

Parameter	Frequency	Min.	Typ.	Max.	Unit	
Insertion Loss	Ant-RF1, RF2, RF3	0.1–0.5 GHz		0.55	0.75	dB
		0.5–1.0 GHz		0.60	0.80	dB
		1.0–2.0 GHz		0.80	1.10	dB
Isolation	Ant-RF1, RF2, RF3	0.1–0.5 GHz	25	28		dB
		0.5–1.0 GHz	22	25		dB
		1.0–2.0 GHz	22	25		dB
Return Loss	Ant-RF1, RF2, RF3	0.1–0.5 GHz		18		dB
		0.5–1.0 GHz		18		dB
		1.0–2.0 GHz		14		dB

Operating Characteristics at 25°C (0, +2.75 V)

Parameter	Condition	Frequency	Min.	Typ.	Max.	Unit
2nd Harmonic	34 dBm In @ 2.75 V	1 GHz		72		dBc
3rd Harmonic	34 dBm In @ 2.75 V	1 GHz		65		dBc
2nd Harmonic	32 dBm In @ 2.75 V	2 GHz		70		dBc
3rd Harmonic	32 dBm In @ 2.75 V	2 GHz		65		dBc
Gate Leakage Current	34 dBm In @ 2.75 V				0.030	mA
Control Voltages	V_{High}		-0.25	0	0.25	V
	V_{Low}		2.60	2.75	5.00	V

Typical Performance Data (0, +2.75 V, $C_{BL} = 47$ pF)

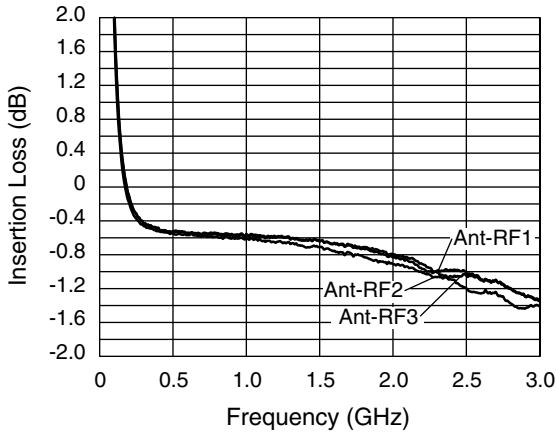

Insertion Loss vs. Frequency

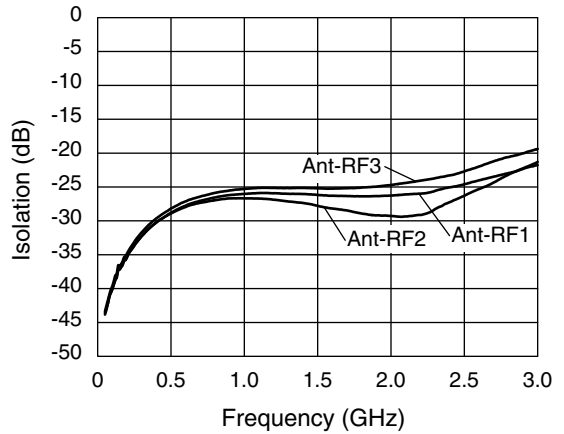

Isolation vs. Frequency

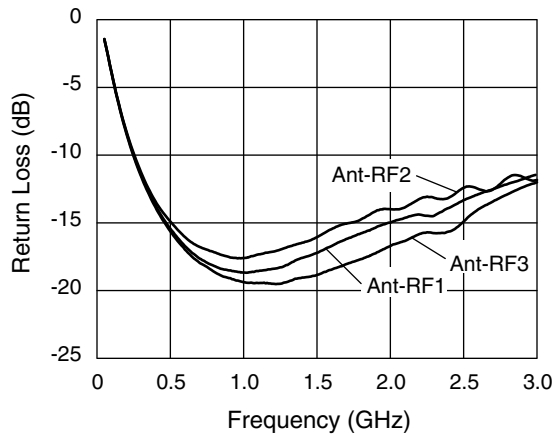

Return Loss vs. Frequency

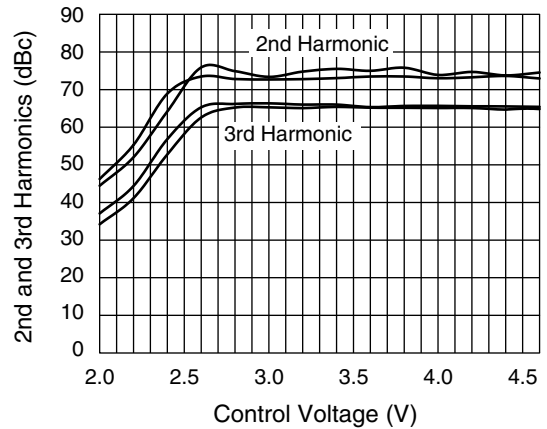

2nd and 3rd Harmonics vs. Control Voltage

Truth Table

V ₁	V ₂	V ₃	Ant-RF1	Ant-RF2	Ant-RF3
V _{High}	V _{Low}	V _{Low}	Ins. Loss	Isolation	Isolation
V _{Low}	V _{High}	V _{Low}	Isolation	Ins. Loss	Isolation
V _{Low}	V _{Low}	V _{High}	Isolation	Isolation	Ins. Loss

V_{Low} = 0–0.2 V.
V_{High} = 2.75–5 V.

Pin Out

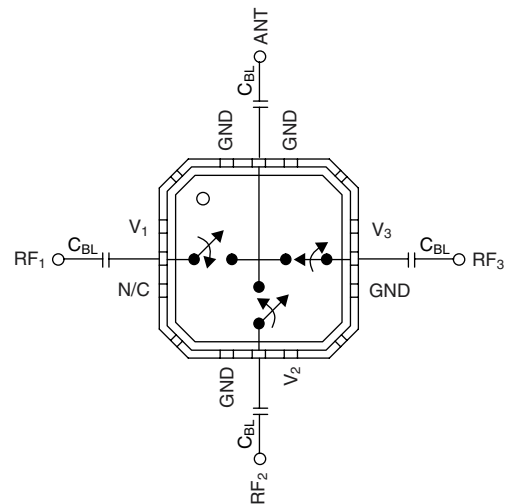

DC blocks required. $C_{BL} = 47$ pF for operation >500 MHz.