

SOJ, TSOP
Commercial Temp
Industrial Temp

256K x 8 2Mb Asynchronous SRAM

8, 10, 12, 15 ns
3.3 V V_{DD}
Center V_{DD} and V_{SS}

Features

- Fast access time: 8, 10, 12, 15 ns
- CMOS low power operation: 150/125/110/90 mA at minimum cycle time.
- Single 3.3 V \pm 0.3 V power supply
- All inputs and outputs are TTL-compatible
- Fully static operation
- Industrial Temperature Option: -40° to 85° C
- Package line up
 - J: 400 mil, 36-pin SOJ package
 - TP: 400 mil, 44-pin TSOP Type II package

Description

The GS72108 is a high speed CMOS Static RAM organized as 262,144 words by 8 bits. Static design eliminates the need for external clocks or timing strobes. The GS operates on a single 3.3 V power supply and all inputs and outputs are TTL-compatible. The GS72108 is available in 400 mil SOJ and 400 mil TSOP Type-II packages.

SOJ 256K x 8-Pin Configuration

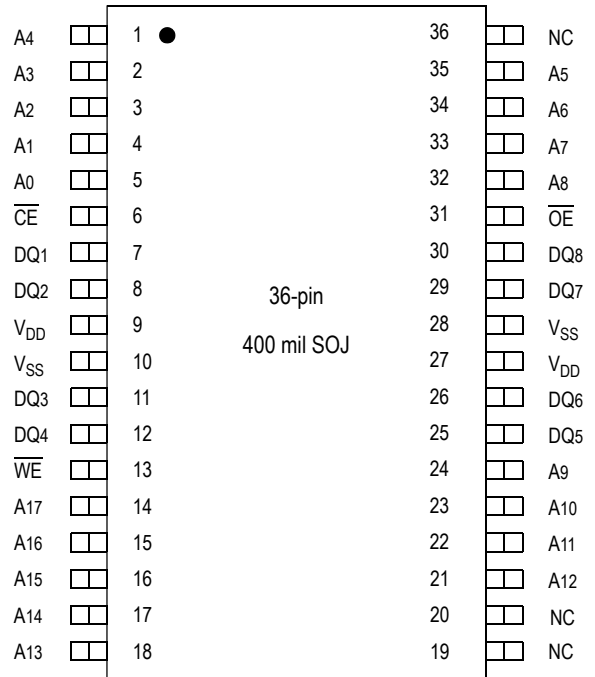

Pin Descriptions

Symbol	Description
A ₀ –A ₁₇	Address input
DQ ₁ –DQ ₈	Data input/output
\overline{CE}	Chip enable input
\overline{WE}	Write enable input
\overline{OE}	Output enable input
V_{DD}	+3.3 V power supply
V_{SS}	Ground
NC	No connect

TSOP-II 256K x 8-Pin Configuration

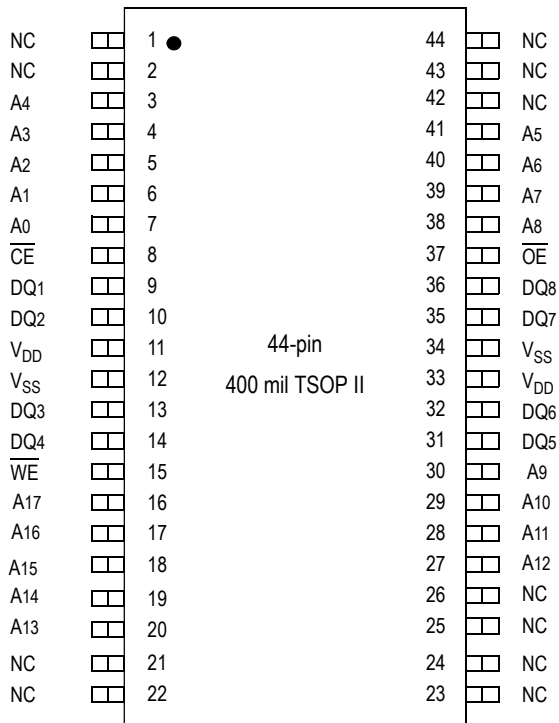

Block Diagram

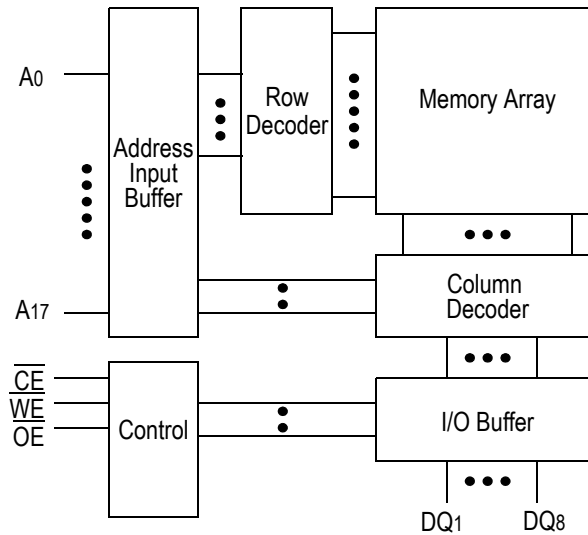

Truth Table

$\overline{\text{CE}}$	$\overline{\text{OE}}$	$\overline{\text{WE}}$	DQ1 to DQ8	V _{DD} Current
H	X	X	Not Selected	ISB1, ISB2
L	L	H	Read	I _{DD}
L	X	L	Write	
L	H	H	High Z	

Note: X: "H" or "L"

Absolute Maximum Ratings

Parameter	Symbol	Rating	Unit
Supply Voltage	V _{DD}	-0.5 to +4.6	V
Input Voltage	V _{IN}	-0.5 to V _{DD} +0.5 (≤ 4.6 V max.)	V
Output Voltage	V _{OUT}	-0.5 to V _{DD} +0.5 (≤ 4.6 V max.)	V
Allowable power dissipation	PD	0.7	W
Storage temperature	T _{STG}	-55 to 150	°C

Note:

Permanent device damage may occur if Absolute Maximum Ratings are exceeded. Functional operation shall be restricted to Recommended Operating Conditions. Exposure to higher than recommended voltages for extended periods of time could affect device reliability.

Recommended Operating Conditions

Parameter	Symbol	Min	Typ	Max	Unit
Supply Voltage for -10/12/15	V_{DD}	3.0	3.3	3.6	V
Supply Voltage for -8	V_{DD}	3.135	3.3	3.6	V
Input High Voltage	V_{IH}	2.0	—	$V_{DD} + 0.3$	V
Input Low Voltage	V_{IL}	-0.3	—	0.8	V
Ambient Temperature, Commercial Range	T_{Ac}	0	—	70	°C
Ambient Temperature, Industrial Range	T_{AI}	-40	—	85	°C

Note:

1. Input overshoot voltage should be less than $V_{DD} + 2$ V and not exceed 20 ns.
2. Input undershoot voltage should be greater than -2 V and not exceed 20 ns.

Capacitance

Parameter	Symbol	Test Condition	Max	Unit
Input Capacitance	C_{IN}	$V_{IN} = 0$ V	5	pF
Output Capacitance	C_{OUT}	$V_{OUT} = 0$ V	7	pF

Notes:

1. Tested at $T_A = 25^\circ\text{C}$, $f = 1$ MHz
2. These parameters are sampled and are not 100% tested.

DC I/O Pin Characteristics

Parameter	Symbol	Test Conditions	Min	Max
Input Leakage Current	I_{IL}	$V_{IN} = 0$ to V_{DD}	-1 μA	1 μA
Output Leakage Current	I_{LO}	Output High Z $V_{OUT} = 0$ to V_{DD}	-1 μA	1 μA
Output High Voltage	V_{OH}	$I_{OH} = -4$ mA	2.4	—
Output Low Voltage	V_{OL}	$I_{LO} = +4$ mA	—	0.4 V

Power Supply Currents

Parameter	Symbol	Test Conditions	0 to 70°C				-40 to 85°C		
			8 ns	10 ns	12 ns	15 ns	10 ns	12 ns	15 ns
Operating Supply Current	I _{DD} (max)	$\overline{CE} \leq V_{IL}$ All other inputs $\geq V_{IH}$ or $\leq V_{IL}$ Min. cycle time I _{OUT} = 0 mA	150 mA	125 mA	110 mA	90 mA	135 mA	120 mA	100 mA
Standby Current	I _{SB1} (max)	$\overline{CE} \geq V_{IH}$ All other inputs $\geq V_{IH}$ or $\leq V_{IL}$ Min. cycle time	55 mA	50 mA	45 mA	40 mA	60 mA	55 mA	50 mA
Standby Current	I _{SB2} (max)	$\overline{CE} \geq V_{DD} - 0.2 V$ All other inputs $\geq V_{DD} - 0.2 V$ or $\leq 0.2 V$	15 mA				25 mA		

AC Test Conditions

Parameter	Conditions
Input high level	V _{IH} = 2.4 V
Input low level	V _{IL} = 0.4 V
Input rise time	t _r = 1 V/ns
Input fall time	t _f = 1 V/ns
Input reference level	1.4 V
Output reference level	1.4 V
Output load	Fig. 1 & 2

Note:

1. Include scope and jig capacitance.
2. Test conditions as specified with output loading as shown in **Fig. 1** unless otherwise noted.
3. Output load 2 for t_{LZ}, t_{HZ}, t_{OLZ} and t_{OZH}

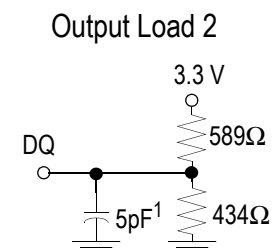
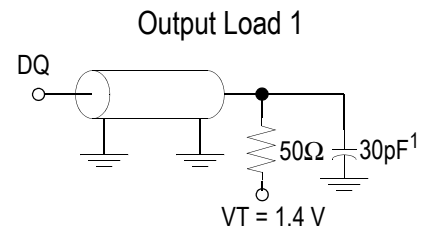

AC Characteristics

Read Cycle

Parameter	Symbol	-8		-10		-12		-15		Unit
		Min	Max	Min	Max	Min	Max	Min	Max	
Read cycle time	t_{RC}	8	—	10	—	12	—	15	—	ns
Address access time	t_{AA}	—	8	—	10	—	12	—	15	ns
Chip enable access time (\overline{CE})	t_{AC}	—	8	—	10	—	12	—	15	ns
Output enable to output valid (\overline{OE})	t_{OE}	—	3.5	—	4	—	5	—	6	ns
Output hold from address change	t_{OH}	3	—	3	—	3	—	3	—	ns
Chip enable to output in low Z (\overline{CE})	t_{LZ}^*	3	—	3	—	3	—	3	—	ns
Output enable to output in low Z (\overline{OE})	t_{OLZ}^*	0	—	0	—	0	—	0	—	ns
Chip disable to output in High Z (\overline{CE})	t_{HZ}^*	—	4	—	5	—	6	—	7	ns
Output disable to output in High Z (\overline{OE})	t_{OHZ}^*	—	3.5	—	4	—	5	—	6	ns

* These parameters are sampled and are not 100% tested.

Read Cycle 1: $\overline{CE} = \overline{OE} = V_{IL}$, $\overline{WE} = V_{IH}$

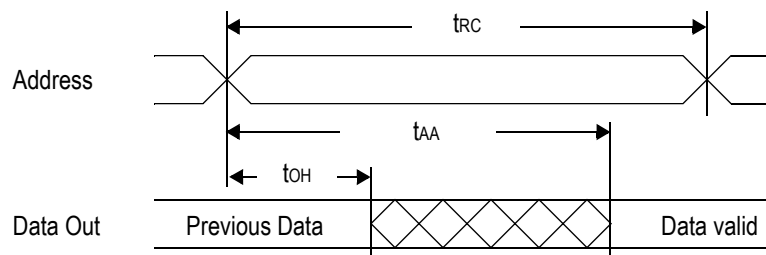

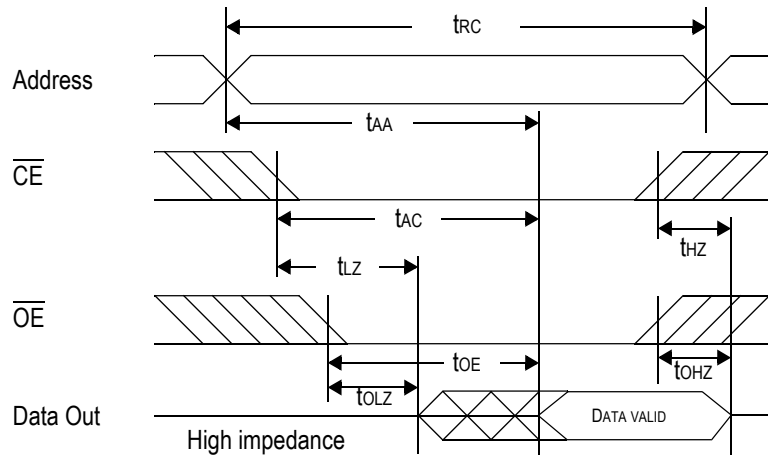
Read Cycle 2: $\overline{WE} = V_{IH}$

Write Cycle

Parameter	Symbol	-8		-10		-12		-15		Unit
		Min	Max	Min	Max	Min	Max	Min	Max	
Write cycle time	t_{WC}	8	—	10	—	12	—	15	—	ns
Address valid to end of write	t_{AW}	5.5	—	7	—	8	—	10	—	ns
Chip enable to end of write	t_{CW}	5.5	—	7	—	8	—	10	—	ns
Data set up time	t_{DW}	4	—	5	—	6	—	7	—	ns
Data hold time	t_{DH}	0	—	0	—	0	—	0	—	ns
Write pulse width	t_{WP}	5.5	—	7	—	8	—	10	—	ns
Address set up time	t_{AS}	0	—	0	—	0	—	0	—	ns
Write recovery time (\overline{WE})	t_{WR}	0	—	0	—	0	—	0	—	ns
Write recovery time (\overline{CE})	t_{WR1}	0	—	0	—	0	—	0	—	ns
Output Low Z from end of write	t_{WLZ}^*	3	—	3	—	3	—	3	—	ns
Write to output in High Z	t_{WHZ}^*	—	3.5	—	4	—	5	—	6	ns

* These parameters are sampled and are not 100% tested.

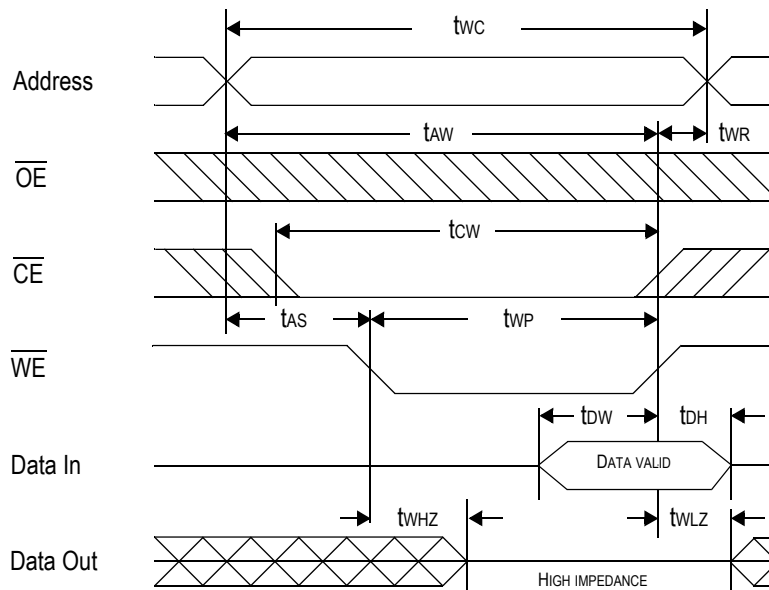
Write Cycle 1: \overline{WE} control



Write Cycle 2: \overline{CE} control

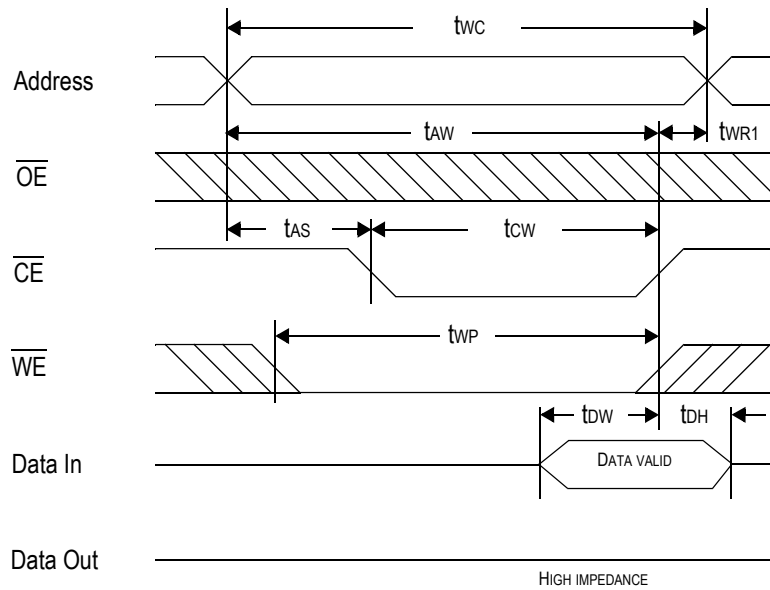

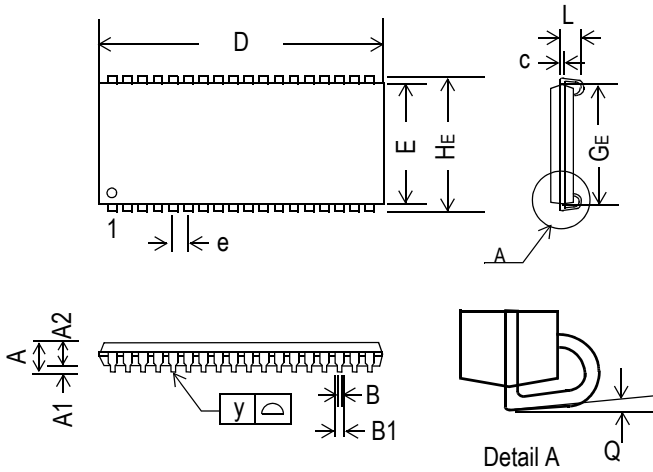
36-Pin SOJ, 400 mil

Symbol	Dimension in inch			Dimension in mm		
	min	nom	max	min	nom	max
A	—	—	0.146	—	—	3.70
A1	0.026	—	—	0.66	—	—
A2	0.105	0.110	0.115	2.67	2.80	2.92
B	0.013	0.017	0.021	0.33	0.43	0.53
B1	0.024	0.028	0.032	0.61	0.71	0.81
c	0.006	0.008	0.012	0.15	0.20	0.30
D	0.920	0.924	0.929	23.37	23.47	23.60
E	0.395	0.400	0.405	10.04	10.16	10.28
e	—	0.05	—	—	1.27	—
HE	0.430	0.435	0.440	10.93	11.05	11.17
GE	0.354	0.366	0.378	9.00	9.30	9.60
L	0.082	—	—	2.08	—	—
y	—	—	0.004	—	—	0.10
Q	0°	—	10°	0°	—	10°

Note:

1. Dimension D & E do not include interlead flash.
2. Dimension B1 does not include dambar protrusion/intrusion.
3. Controlling dimension: inches

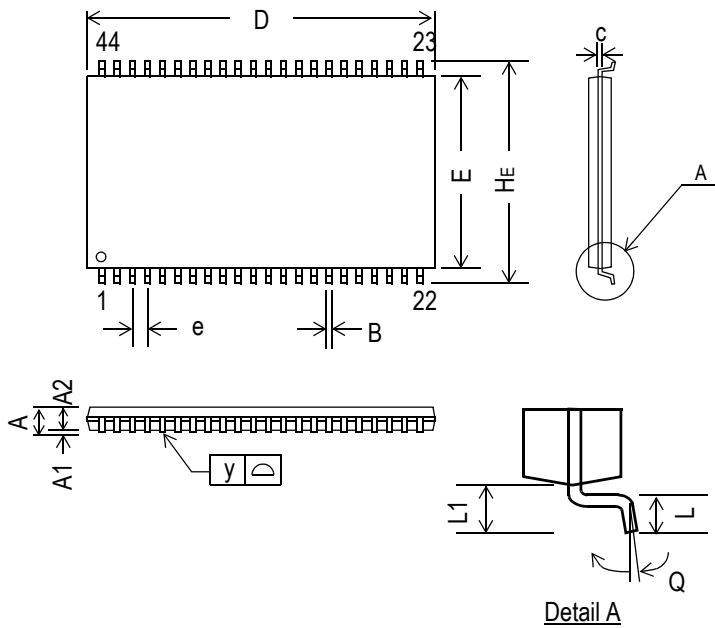
44-Pin, 400 mil TSOP-II

Symbol	Dimension in inch			Dimension in mm		
	min	nom	max	min	nom	max
A	—	—	0.047	—	—	1.20
A1	0.002	—	—	0.05	—	—
A2	0.037	0.039	0.041	0.95	1.00	1.05
B	0.01	0.014	0.018	0.25	0.35	0.45
c	—	0.006	—	—	0.15	—
D	0.721	0.725	0.729	18.31	18.41	18.51
E	0.396	0.400	0.404	10.06	10.16	10.26
e	—	0.031	—	—	0.80	—
H _E	0.455	0.463	0.471	11.56	11.76	11.96
L	0.016	0.020	0.024	0.40	0.50	0.60
L1	—	0.031	—	—	0.80	—
y	—	—	0.004	—	—	0.10
Q	0°	—	5°	0°	—	5°

Note:

1. Dimension D & E do not include interlead flash.
2. Dimension B does not include dambar protrusion/intrusion.
3. Controlling dimension: mm

Ordering Information

Part Number *	Package	Access Time	Temp. Range	Status
GS72108TP-8	400 mil TSOP-II	8 ns	Commercial	
GS72108TP-10	400 mil TSOP-II	10 ns	Commercial	
GS72108TP-12	400 mil TSOP-II	12 ns	Commercial	
GS72108TP-15	400 mil TSOP-II	15 ns	Commercial	
GS72108TP-8I	400 mil TSOP-II	8 ns	Industrial	
GS72108TP-10I	400 mil TSOP-II	10 ns	Industrial	
GS72108TP-12I	400 mil TSOP-II	12 ns	Industrial	
GS72108TP-15I	400 mil TSOP-II	15 ns	Industrial	
GS72108J-8	400 mil SOJ	8 ns	Commercial	
GS72108J-10	400 mil SOJ	10 ns	Commercial	
GS72108J-12	400 mil SOJ	12 ns	Commercial	
GS72108J-15	400 mil SOJ	15 ns	Commercial	
GS72108J-8I	400 mil SOJ	8 ns	Industrial	
GS72108J-10I	400 mil SOJ	10 ns	Industrial	
GS72108J-12I	400 mil SOJ	12 ns	Industrial	
GS72108J-15I	400 mil SOJ	15 ns	Industrial	

* Customers requiring delivery in Tape and Reel should add the character "T" to the end of the part number. For example: GS72108TP-8T

Revision History

Rev. Code: Old; New	Types of Changes Format or Content	Page #/Revisions/Reason
72108 1.04d 5/1999/721081.05 1/ 2000	Content	• Page 2/Pins 16–20 and 26–30 on 44-pin TSOP II Pin Configuration/ Correction
GS72108Rev1.05 10/19991/ 2000K;Rev 5 2/2000L	Format/Content	• GSI Logo
721081.05 1/2000	Content	• Corrected TSOP-II pin configuration diagram (A17–A13 in lower left quadrant; A9–A12, A18 in lower right quadrant)
	Format	• Updated format to comply with Technical Publications standard • Specifically noted that numbers in Power Supply Currents table are worst case scenario
72108_r1_07; 72108_r1_08	Content	• Removed all references to “U” package