



CAT3200, CAT3200-5

Low Noise Regulated Charge Pump DC-DC Converter

FEATURES

- Constant high frequency (2MHz) operation
- 100mA output current
- Regulated output voltage (5V fixed CAT3200-5, Adjustable CAT3200)
- Low quiescent current (1.7mA typ.)
- Input voltage operation down to 2.7V
- Soft start, slew rate control
- Thermal overload shutdown protection
- Low value external capacitors (1μF)
- Foldback current overload protection
- Shutdown current less than 1μA
- CAT3200-5 in low profile (1mm thin) 6-lead SOT23 package
- CAT3200 in MSOP-8 and in low profile (0.8mm thin) TDFN packages

APPLICATIONS

- 3V to 5V boost conversion
- White LED driver
- USB On-The-Go 5V supply
- Local 5V supply from lower rail
- Battery backup systems
- Handheld portable devices

DESCRIPTION

The CAT3200 and CAT3200-5 are switched capacitor boost converters that deliver a low noise, regulated output voltage. The CAT3200-5 gives a fixed regulated 5V output. The CAT3200 has an adjustable output using external resistors. The constant frequency 2MHz charge pump allows small 1μF ceramic capacitors to be used.

Maximum output loads of up to 100mA can be supported over a wide range of input supply voltages (2.7V to 4.5V) making the device ideal for battery-powered applications.

A shutdown control input allows the device to be placed in power-down mode, reducing the supply current to less than 1μA.

In the event of short circuit or overload conditions, the device is fully protected by both foldback current limiting and thermal overload detection. In addition, a soft start, slew rate control circuit limits inrush current during power-up.

The CAT3200-5 is available in a 6-lead, 1mm max thin SOT23 package. The CAT3200 is available in an 8-lead MSOP package and an 8-pad 0.8mm thin TDFN package.

TYPICAL APPLICATION

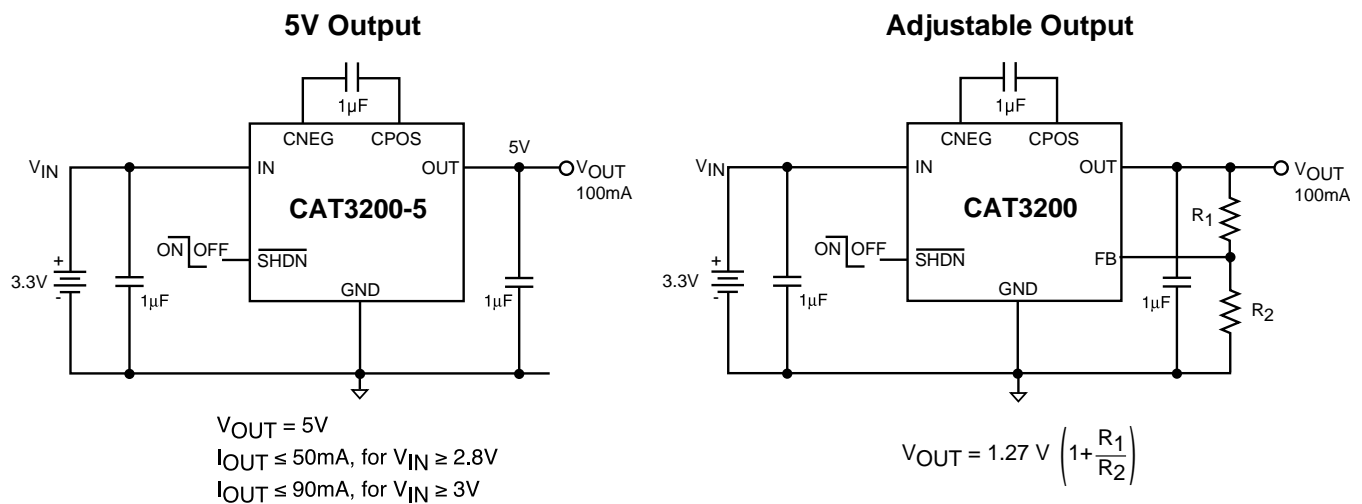

ORDERING INFORMATION

Part Number	Output Voltage	Package Marking	Quantity per Reel	Package
CAT3200ES6-5-TE7	5V	BJ	3,000	6-lead thin SOT23, Tape & Reel (1mm Max Height)
CAT3200ES6-5-TE13	5V	BJ	10,000	6-lead thin SOT23, Tape & Reel (1mm Max Height)
CAT3200EMS8-TE13	Adjustable	AATR	2500	8-lead MSOP, Tape & Reel
CAT3200ERD4-TE13	Adjustable		3500	TDFN 3x3mm, Tape & Reel

PIN DESCRIPTIONS

Pin Number			Designation	Description
CAT3200-5 SOT23	CAT3200 MSOP	CAT3200 TDFN		
1	8	8	OUT	Regulated output voltage.
2			GND	Ground reference for all voltages.
3	6	6	$\overline{\text{SHDN}}$	Shutdown control logic input (Active LOW)
4	3	3	CNEG	Negative connection for the flying capacitor.
5	2	2	IN	Input power supply.
6	1	1	CPOS	Positive connection for the flying capacitor.
	7	7	FB	Feedback to set the output voltage.
	4	4	PGND	Power ground.
	5	5	SGND	Signal ground.

PIN CONFIGURATION

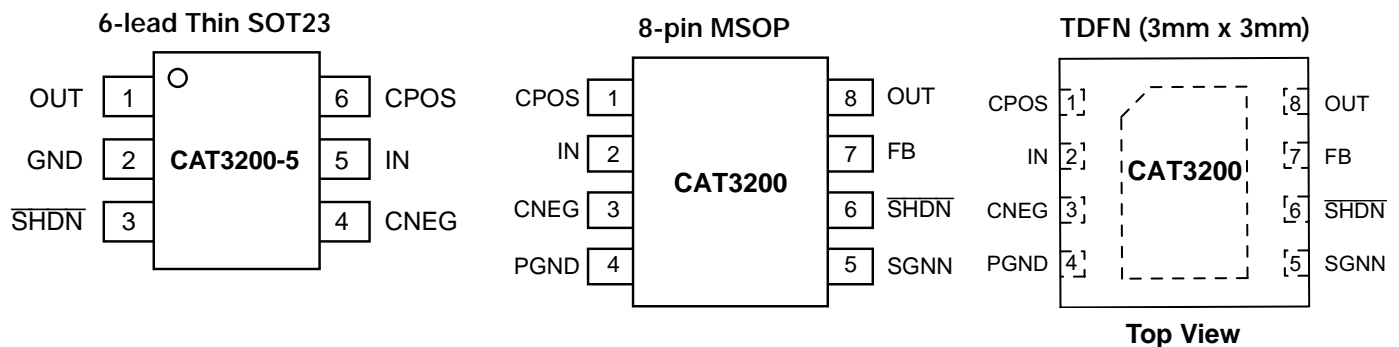

ABSOLUTE MAXIMUM RATINGS

V_{IN} , V_{OUT} , \overline{SHDN} , C_{NEG} , C_{POS} Voltage ..	-0.6V to 6.0V
V_{OUT} Short Circuit Duration	Indefinite
Output Current	200mA
ESD Protection (HBM)	2000V
Junction Temperature	150°C
Storage Temperature Range	-65°C to 160°C
Lead Soldering Temperature (10 sec)	300°C
Power Dissipation (SOT23-6)	0.3W

Power Dissipation (8-MSOP)	0.5W
Power Dissipation (8-TDFN)	1.0W

RECOMMENDED OPERATING CONDITIONS

V_{IN}	2.7V to 4.5V
C_{IN} , C_{OUT} , C_{FLY}	1 μ F
I_{LOAD}	0 to 100mA
Ambient Temperature Range	-40°C to 85°C

ELECTRICAL SPECIFICATIONS

Recommended operating conditions unless otherwise specified. C_{IN} , C_{OUT} , C_{FLY} are 1 μ F ceramic capacitors and V_{IN} is set to 3.6V.

Symbol	Parameter	Conditions	Min	Typ	Max	Units
V_{OUT}	Regulated Output	$I_{LOAD} \leq 40\text{mA}$, $V_{IN} \geq 2.7\text{V}$ $I_{LOAD} \leq 100\text{mA}$, $V_{IN} \geq 3.1\text{V}$	4.8	5.0	5.2	V
V_{LINE}	Line Regulation	$3.1\text{V} \leq V_{IN} \leq 4.5\text{V}$, $I_{LOAD} = 50\text{mA}$		6		mV
V_{LOAD}	Load Regulation	$I_{LOAD} = 10\text{mA}$ to 100mA, $V_{IN} = 3.6\text{V}$		20		mV
F_{OSC}	Switching Frequency		1.0	2.0	2.6	MHz
V_R	Output Ripple Voltage	$I_{LOAD} = 100\text{mA}$, $V_{IN} = 3\text{V}$ CAT3200-5 Only		30		mVp-p
η	Efficiency	$I_{LOAD} = 50\text{mA}$, $V_{IN} = 3\text{V}$, CAT3200-5		80		%
I_{GND}	Ground Current	$I_{LOAD} = 0\text{mA}$, $\overline{SHDN} = V_{IN}$		1.6	4	mA
I_{SHDN}	Shutdown Input Current	$I_{LOAD} = 0\text{mA}$, $\overline{SHDN} = 0\text{V}$ to V_{IN}	-1		1	μ A
V_{FB}	FB Voltage	CAT3200 Only	1.22	1.27	1.32	V
I_{FB}	FB Input Current	CAT3200 Only	-50		50	nA
R_{OL}	Open-Loop Resistance	$I_{LOAD} = 100\text{mA}$, $V_{IN} = 3\text{V}$ (Note 1)		10		Ω
T_{ON}	V_{OUT} Turn-on time (10% to 90%)	$I_{LOAD} = 0\text{mA}$, $V_{IN} = 3\text{V}$		0.5		ms
V_{IHSHDN}	High Detect Shutdown Threshold		1.3	0.8		V
V_{ILSHDN}	Low Detect High Detect Threshold				0.4	V
I_{ROUT}	Reverse Leakage into OUT pin	$V_{OUT} = 5\text{V}$, Shutdown mode (Note 2)		15	30	μ A
I_{SC}	Short-circuit Output	$V_{OUT} = 0\text{V}$		80		mA
T_{SD}	Thermal Shutdown			160		°C
T_{HYST}	Thermal Hysteresis			20		°C

Note 1: $R_{OL} = (2V_{IN} - V_{OUT})/I_{OUT}$

Note 2: In the event of a controlled shutdown, the output will be isolated from the input, but will remain connected to the internal resistor feedback network. This will cause a small level of reverse current to flow back into the device to ground.

TYPICAL PERFORMANCE CHARACTERISTICS (CAT3200-5)

$T_{AMB}=25^{\circ}C$, $C_{IN}=C_{OUT}=C_{FLY}=1\mu F$, $V_{IN}=3.3V$ unless specified otherwise.

Shutdown Input Threshold vs. Supply Voltage

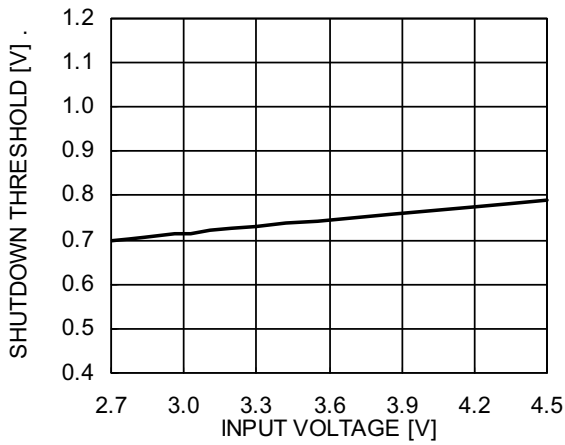

Ground Current vs. Supply Voltage (No Load)

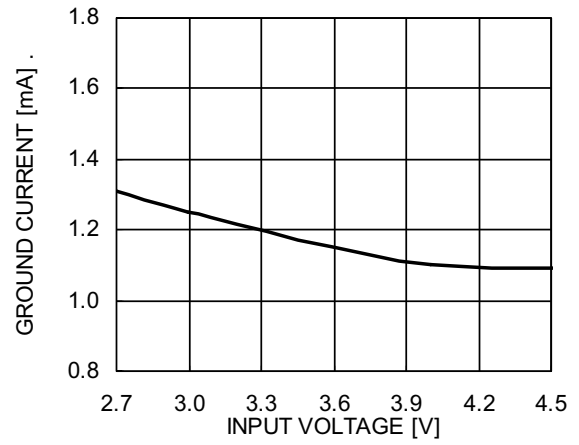

Line Regulation

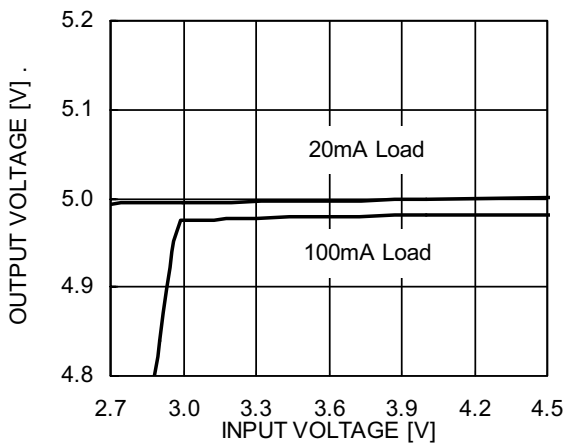

Load Regulation

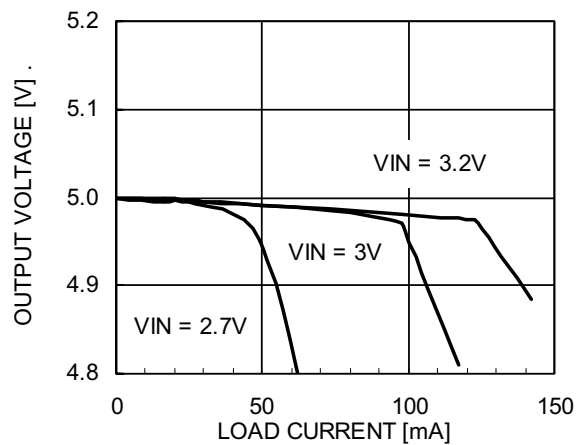

Oscillator Frequency vs. Supply Voltage

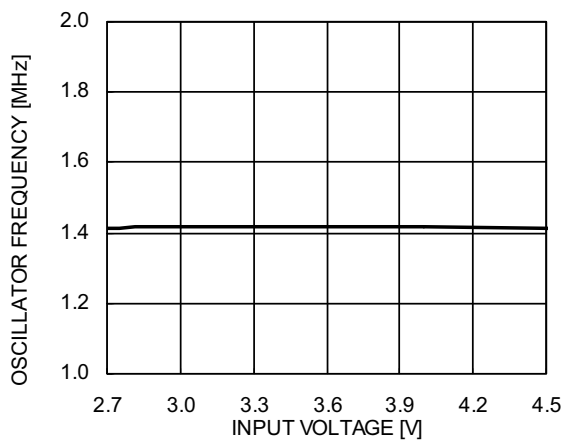

Efficiency vs. Load Current

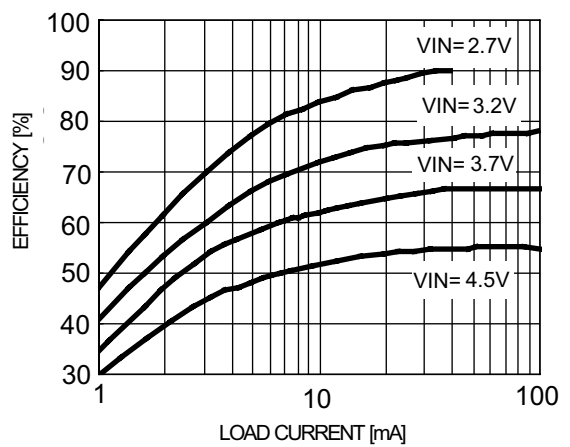

TYPICAL PERFORMANCE CHARACTERISTICS (CAT3200-5)

$T_{AMB}=25^{\circ}\text{C}$, $C_{IN}=C_{OUT}=C_{FLY}=1\mu\text{F}$, $V_{IN}=3.3\text{V}$ unless specified otherwise.

Soft Start Power Up (90mA Load, 3.3V Input)

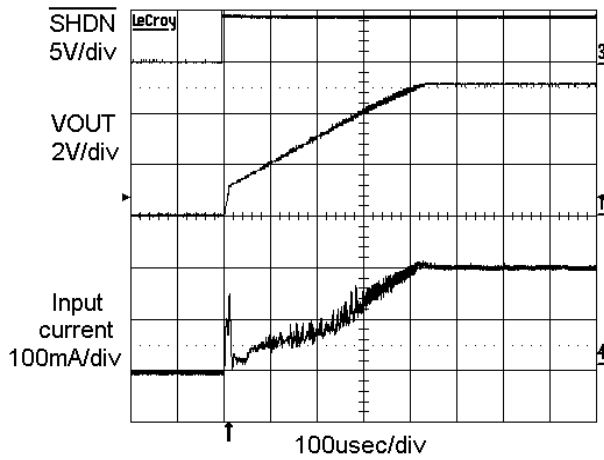

Load Step Response (3.3V Input)

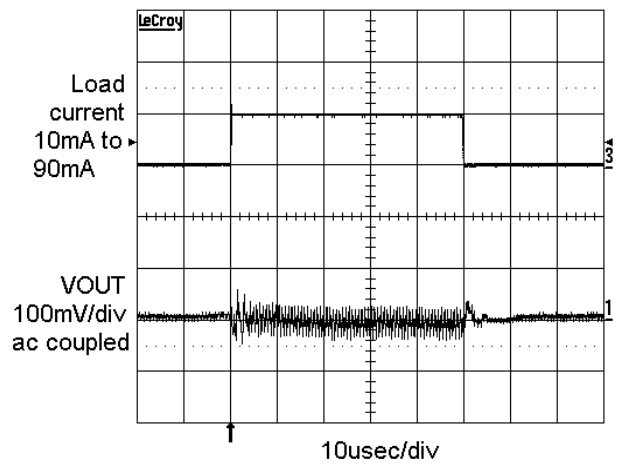

Output Ripple (100mA Load, 3.3V Input)

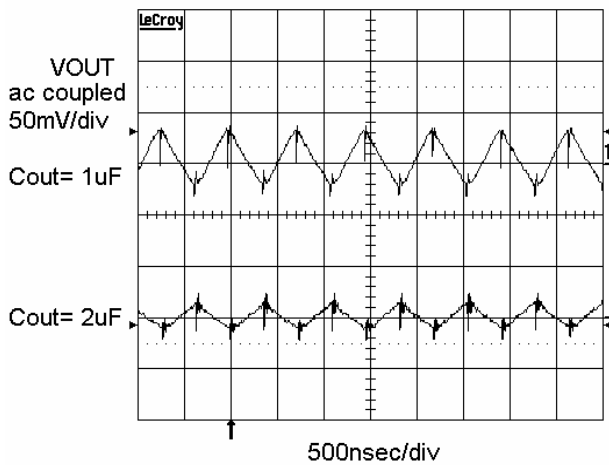

Short Circuit Current vs Supply Voltage

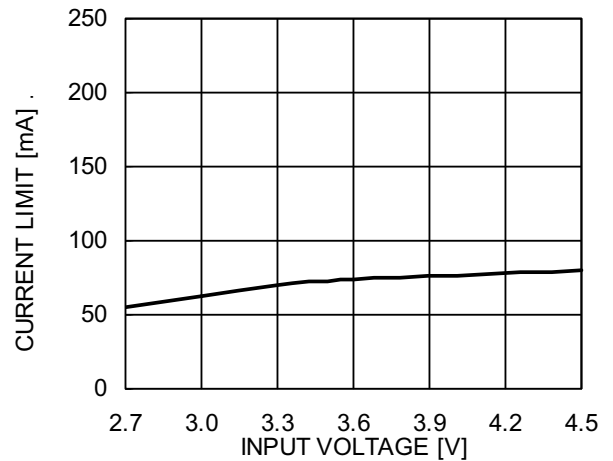

Output Voltage Change vs. Temperature

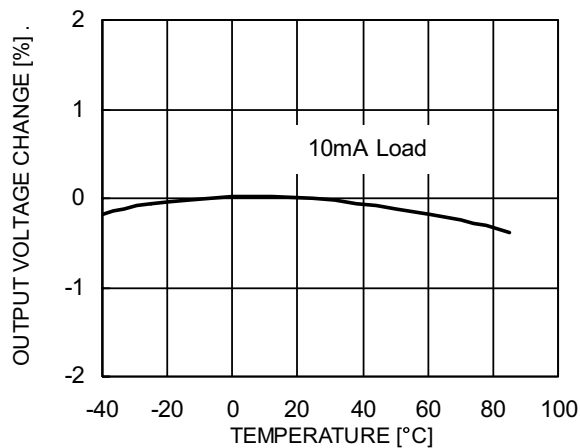

Oscillator Frequency Change vs. Temperature

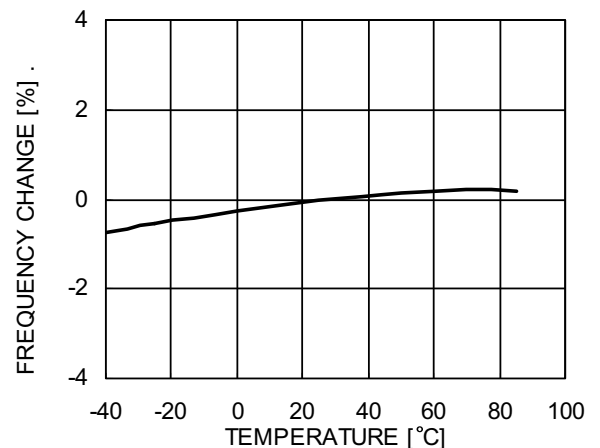

BLOCK DIAGRAM

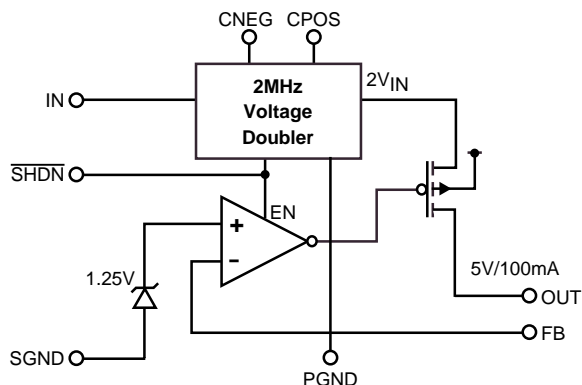

CAT3200 Adjustable Output

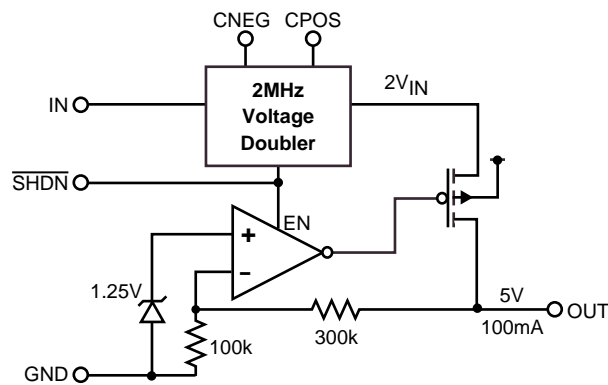

CAT3200-5 5V Fixed Output

PIN FUNCTIONS

IN is the power supply. During normal operation the device draws a supply current which is almost constant. A very brief interval of non-conduction will occur at the switching frequency. The duration of the non-conduction interval is set by the internal non-overlapping “break-before-make” timing. **IN** should be bypassed with a $1\mu\text{F}$ to $4.7\mu\text{F}$ low ESR (Equivalent Series Resistance) ceramic capacitor.

For filtering, a low ESR ceramic bypass capacitor ($1\mu\text{F}$) in close proximity to the **IN** pin prevents noise from being injected back into the power supply.

SHDN is the logic control input (Active LOW) that places the device into shutdown mode. The internal logic is CMOS and the pin does not use an internal pull-down resistor. The **SHDN** pin should not be allowed to float.

CPOS, **CNEG** are the positive and negative connections respectively for the charge pump flying capacitor. A low ESR ceramic capacitor ($1\mu\text{F}$) should be connected between these pins. During initial power-up it may be possible for the capacitor to experience a voltage reversal and for this reason, avoid using a polarized (tantalum or aluminum) flying capacitor.

OUT is the regulated output voltage to power the load. During normal operation, the device will deliver a train of current pulses to the pin at a frequency of 2MHz. Adequate filtering on the pin can typically be achieved through the use of a low ESR ceramic bypass capacitor ($1\mu\text{F}$ to $4.7\mu\text{F}$) in close proximity to the **OUT** pin. The ESR of the output capacitor will directly influence the output ripple voltage.

When the shutdown mode is entered, the output is immediately isolated from the input supply, however, the output will remain connected to the internal feedback

resistor network ($400\text{k}\Omega$). The feedback network will result in a reverse current of $10\mu\text{A}$ to $20\mu\text{A}$ to flow back through the device to ground.

Whenever the device is taken out of shutdown mode, the output voltage will experience a slew rate controlled power-up. Full operating voltage is typically achieved in less than 0.5 msec.

GND is the ground reference for all voltages on CAT3200-5 devices.

FB (CAT3200 Only) is the feedback input pin. An output divider should be connected from **OUT** to **FB** to program the output voltage.

PGND (CAT3200 Only). Is the same as **GND** for the CAT3200-5 except for the internal reference connection to **SGND**.

SGND (CAT3200 Only) Ground pin for the internal reference. The **CNEG** connection is switched to this pin during the normal charge pump operation.

DEVICE OPERATION

The CAT3200/CAT3200-5 use a switched capacitor charge pump to boost the voltage at IN to a regulated output voltage. Regulation is achieved by sensing the output voltage through an internal resistor divider (CAT3200-5) and modulating the charge pump output current based on the error signal. A 2-phase non-overlapping clock activates the charge pump switches. The flying capacitor is charged from the IN voltage on the first phase of the clock. On the second phase of the clock it is stacked in series with the input voltage and connected to OUT. The charging and discharging the flying capacitor continues at a free running frequency of typically 2MHz.

In shutdown mode all circuitry is turned off and the CAT3200/CAT3200-5 draw only leakage current from the V_{IN} supply. OUT is disconnected from IN. The \overline{SHDN} pin is a CMOS input with a threshold voltage of approximately 0.8V. The CAT3200/CAT3200-5 is in shutdown when a logic LOW is applied to the \overline{SHDN} pin. The \overline{SHDN} pin is a high impedance CMOS input. \overline{SHDN} does not have an internal pull-down resistor and should not be allowed to float and. It must always be driven with a valid logic level.

Short-Circuit and Thermal Protection

The CAT3200 and CAT3200-5 have built-in short-circuit current limiting and over temperature protection. During short-circuit conditions, output current is limited to approximately 225mA. At higher temperatures, or if the input voltage is high enough to cause excessive chip self heating, the thermal shutdown circuit shuts down the charge pump as the junction temperature exceeds approximately 160°C. Once the junction temperature drops back to approximately 155°C, the charge pump is enabled. The CAT3200 and CAT3200-5 will cycle in and out of thermal shutdown indefinitely without latch-up or damage until a short-circuit on OUT is removed.

Programming the CAT3200 Output Voltage (FB Pin)

The CAT3200-5 version has an internal resistive divider to program the output voltage. The programmable CAT3200 may be set to an arbitrary voltage via an external resistive divider. Since it employs a voltage doubling charge pump, it is not possible to achieve output voltages greater than twice the available input voltage. Figure 1 shows the required voltage divider connection. The voltage divider ratio is given by the formula:

$$\frac{R1}{R2} = \frac{V_{OUT}}{1.27V} - 1$$

Typical values for total voltage divider resistance can range from several kΩs up to 1MΩ.

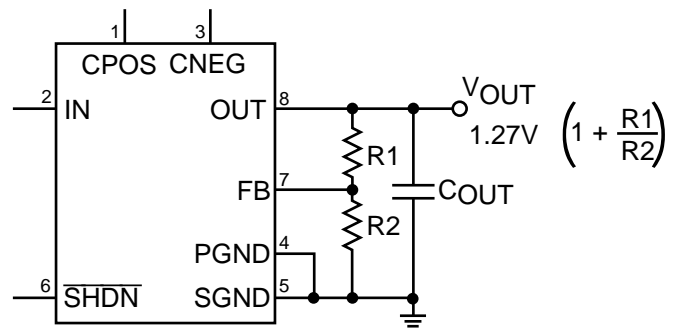

Figure 1: Programming the Adjustable CAT3200

APPLICATION INFORMATION

Ceramic Capacitors

Ceramic capacitors of different dielectric materials lose their capacitance with higher temperature and voltage at different rates. For example, a capacitor made of X5R or X7R material will retain most of its capacitance from –40°C to 85°C whereas a Z5U or Y5V style capacitor will lose considerable capacitance over that range.

Z5U and Y5V capacitors may also have voltage coefficient causing them to lose 60% or more of their capacitance when the rated voltage is applied. When comparing different capacitors it is often useful consider the amount of achievable capacitance for a given case size rather than discussing the specified capacitance value. For example, over rated voltage and temperature conditions, a 1µF, 10V, Y5V ceramic capacitor in an 0603 case may not provide any more capacitance than a 0.22µF, 10V, X7R available in the same 0603 case. For many CAT3200/CAT3200-5 applications these capacitors can be considered roughly equivalent.

The capacitor manufacturer's data sheet should be consulted to determine what value of capacitor is needed to ensure the desired capacitance at all temperatures and voltages. Below is a list of ceramic capacitor manufacturers and how to contact them:

Capacitor Manufacturer	Web	Phone
Murata	www.murata.com	814.237.1431
AVX/Kemet	www.avxcorp.com	843.448.9411
Vishay	www.vishay.com	
Kemet	www.kemet.com	408.986.0424
Taiyo Yuden	www.t-yuden.com	408.573.4150

Thermal Management

For higher input voltages and maximum output current there can be substantial power dissipation in the CAT3200/CAT3200-5. If the junction temperature increases to 150°C, the thermal shutdown circuitry will automatically turn off the output.

A good thermal connection to the PC board is recommended to reduce the chip temperature. Connecting the GND pin (Pins 4/5 for CAT3200, Pin 2 for CAT3200-5) to a ground plane, and maintaining a solid ground plane under the device reduces the overall thermal resistance.

The overall junction to ambient thermal resistance (θ_{JA}) for device power dissipation (P_D) consists primarily of two paths in series. The first path is the junction to the case (θ_{JC}) which is defined by the package style, and the second path is case to ambient (θ_{CA}) thermal resistance which is dependent on board layout. The final operating junction temperature for any set of conditions can be estimated by the following thermal equation:

$$\begin{aligned} T_{JUNC} &= T_{AMB} + P_D(\theta_{JC}) + P_D(\theta_{CA}) \\ &= T_{AMB} + P_D(\theta_{JA}) \end{aligned}$$

The CAT3200 in SOT23 package, when mounted on printed circuit board with two square inches of copper allocated for "heat spreading", will result with an overall θ_{JA} of less than 150°C/W.

For a typical application operating from a 3.8V input supply, the maximum power dissipation is 260mW (100mA x 3V). This would result if a maximum junction temperature of :

$$\begin{aligned} T_{JUNC} &= T_{AMB} + P_D(\theta_{JA}) \\ &= 85^\circ\text{C} + 0.26\text{W}(150^\circ\text{C/W}) \\ &= 85^\circ\text{C} + 39^\circ\text{C} = 124^\circ\text{C} \end{aligned}$$

The use of multi-layer board construction with power planes will further enhance the overall thermal performance. In the event of no dedicated copper area being used for heat spreading, a multi-layer board will typically provide the CAT3200 with an overall θ_{JA} of 200°C/W. This level of thermal conduction would allow up to 200mW be safely dissipated within the device.

TYPICAL APPLICATIONS

3.3 V Supply to 5 V

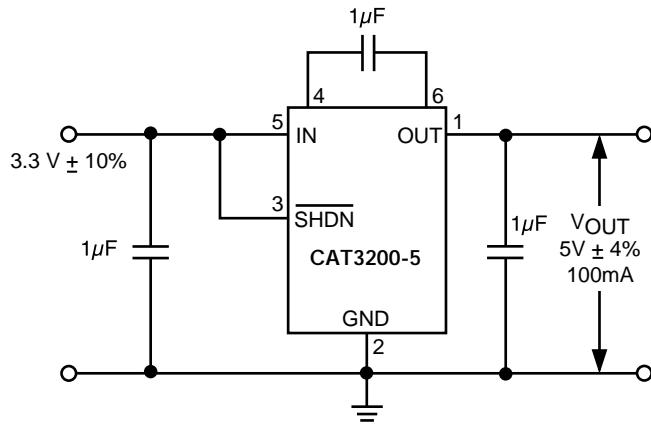

USB Port to Regulated 5V Power Supply

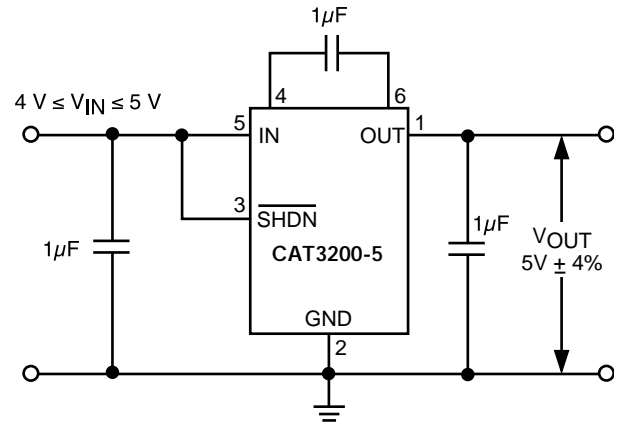

Lithium-Ion Battery to 5V White or Blue LED Driver

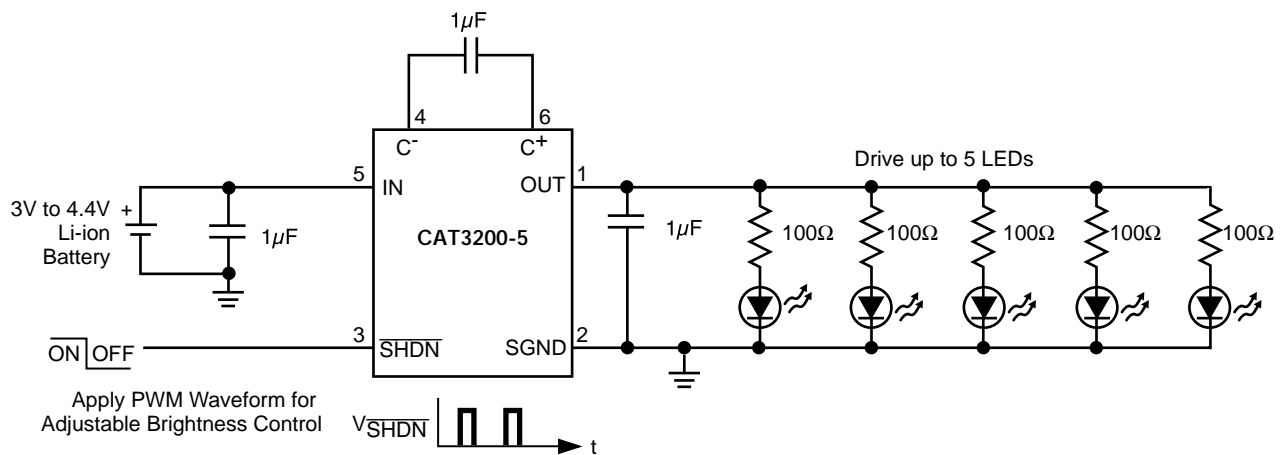

White or Blue LED Driver with LED Current Control

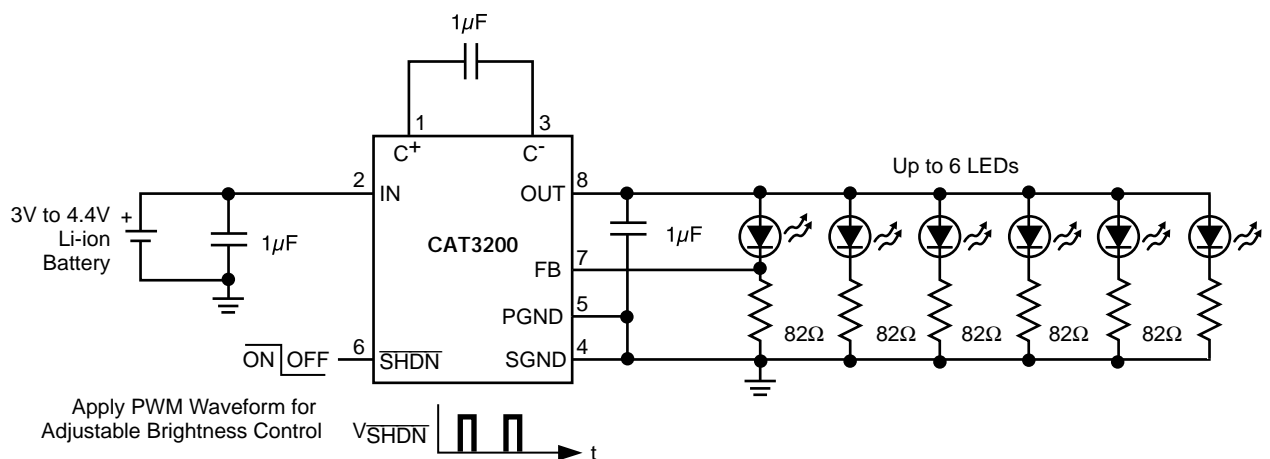

MECHANICAL PACKAGE DRAWINGS

6-LEAD THIN SOT-23

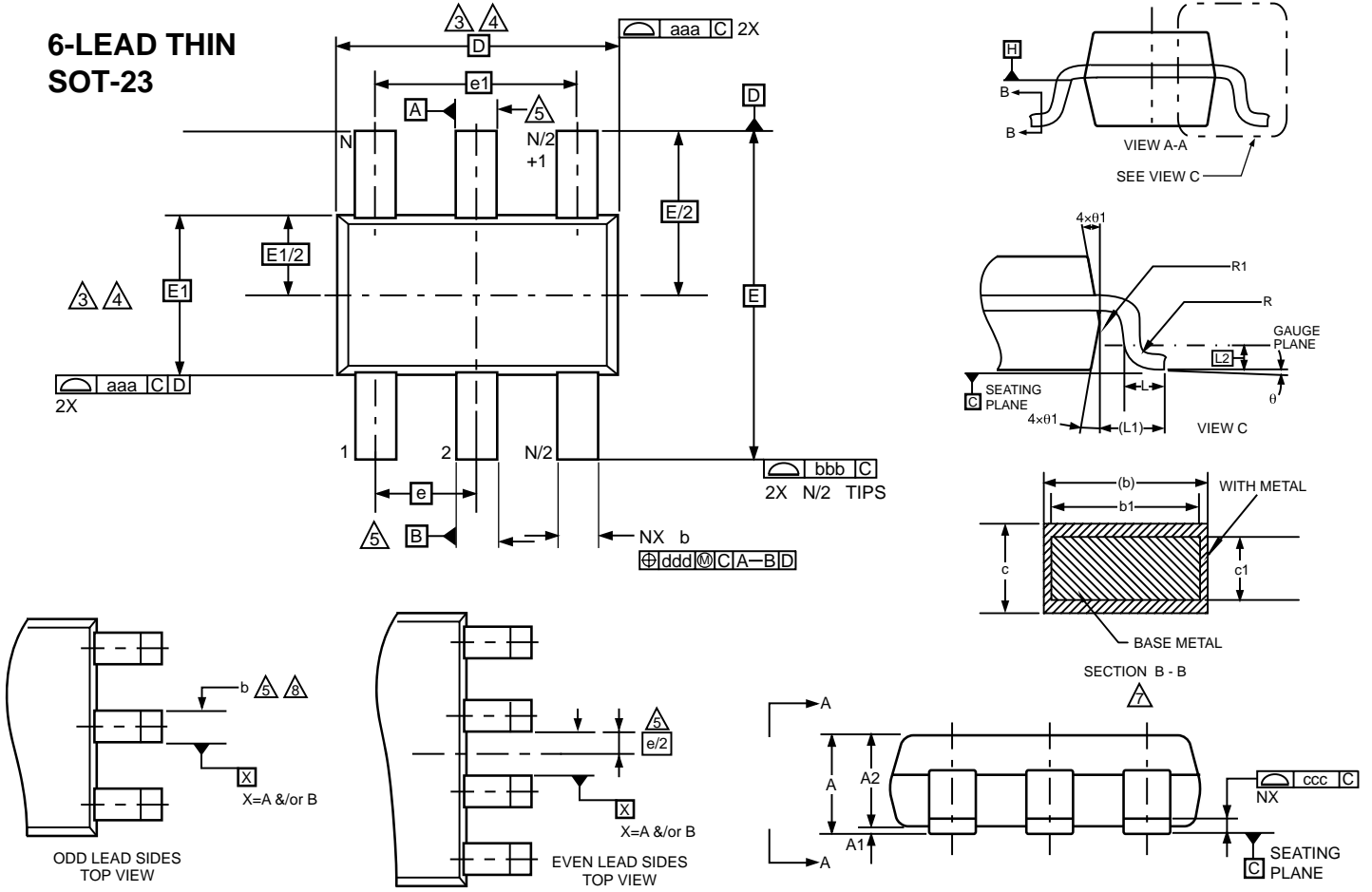

All Dimensions are in Millimeters

	Min	Nom	Max	Notes
A	—	—	1.00	
A1	0.01	0.05	0.10	
A2	0.84	0.87	0.90	
c	0.12	0.15	0.20	7
c1	0.08	0.13	0.16	7
D	2.90BSC			3,4
E	2.80BSC			3,4
E1	1.60BSC			3,4
L	0.30	0.40	0.50	
L1	0.60REF			
L2	0.25BSC			
R	0.10	—	—	
R1	0.10	—	0.25	
θ	0°	4°	8°	
θ1	4°	10°	12°	

Tolerances of Form and Position							Notes			
aaa	0.15						1,2			
bbb	0.25						1,2			
ccc	0.10						1,2			
Variations										
	AA			AB			BA			Notes
b	0.30	—	0.45	0.30	—	0.45	0.22	—	0.36	7,8
b1	0.31	0.35	0.39	0.31	0.35	0.39	0.22	0.26	0.30	
e	0.95BSC			0.95BSC			0.65BSC			
e1	1.90BSC			1.90BSC			1.95BSC			
N	6			5			8			
Tolerances of Form and Position										
ddd	0.20			0.20			0.13			1,2

- Notes:**
- Dimensions and tolerancing per ASME Y14.5M - 1994
 - Dimension are in mm.
 - Dimension D does not include mold flash, protrusions or gate burrs. Mold flash, protrusions or gate burrs shall not exceed 0.15mm per end. Dimension E1 does not include interlead flash or protrusion. Interlead flash or protrusion shall not exceed 0.15mm per side. D and E1 dimensions are determined at Datum H.

- ④ The package top may be smaller than the package bottom. Dimensions D and E1 are determined at the outermost extremes of the plastic body exclusive of mold flash, the bar burrs, gate burrs and interlead flash, but including any mismatch between the top and bottom of the plastic body. D and E1 dimensions are determined at Datum H.
- ⑤ Datums A & B to be determined at Datum H.
- ⑥ Package variation "AB" is a 5 lead version of the 6 lead variation "AA" where lead #5 has been removed from the 6 lead "AA" variation.
- ⑦ These dimensions apply to the flat section of the lead between 0.08mm and 0.15mm from the lead tip.
- ⑧ Dimension "b" does not include dambar protrusion. Allowable dambar protrusion shall be 0.08mm total in excess of the "b" dimension at maximum material condition. The dambar cannot be located on the lower radius of the foot. Minimum space between protrusion and an adjacent lead shall not be less than 0.07mm.

MECHANICAL PACKAGE DRAWINGS

8-LEAD MSOP

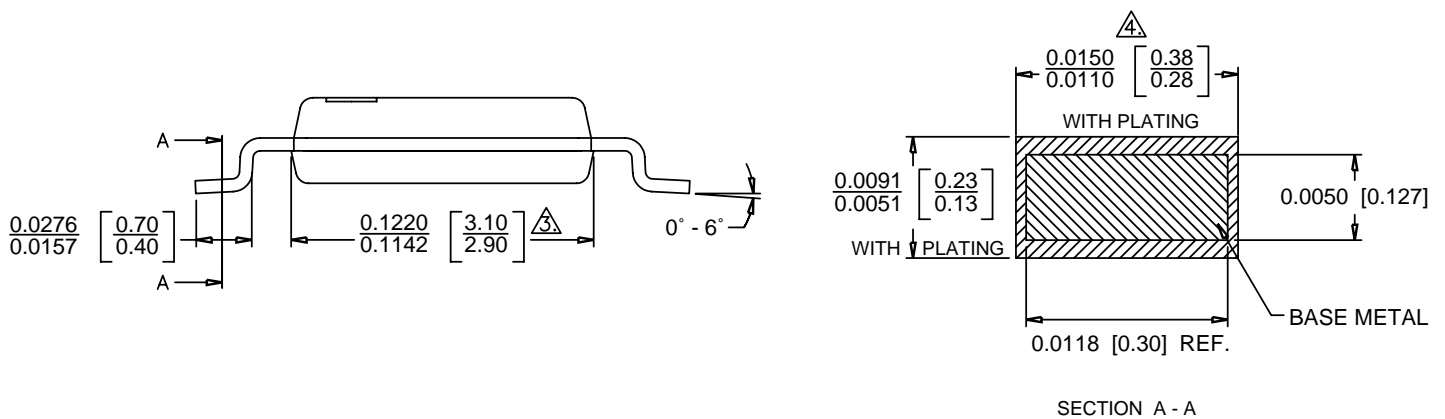
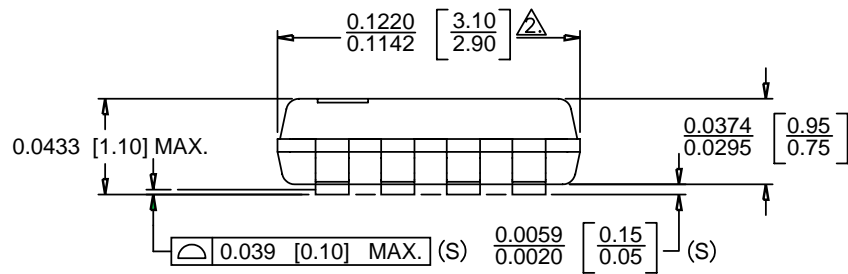
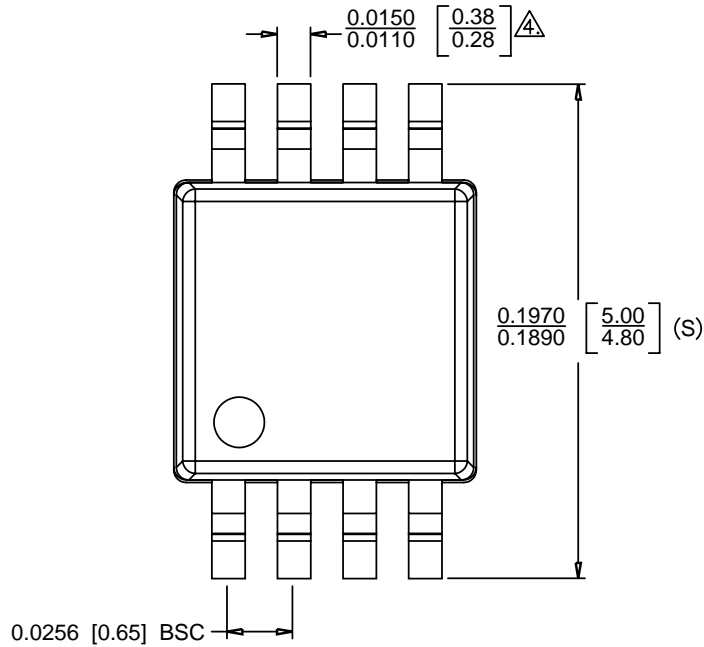

Notes:

- (1) All dimensions are in mm Angles in degrees.
- Δ Does not include Mold Flash, Protrusion or Gate Burrs. Mold Flash, Protrusions or Gate Burrs shall not exceed 0.15 mm. per side.
- Δ Does not include Interlead Flash or Protrusion. Interlead Flash or Protrusion shall not exceed 0.25 mm per side.
- Δ Does not include Dambar Protrusion, allowable Dambar Protrusion shall be 0.08 mm.
- (5) This part is compliant with JEDEC Specification MO-187 Variations AA.
- (6) Lead span/stand off height/coplanarity are considered as special characteristics. (S)
- (7) Controlling dimensions in inches. [mm]

TDFN 3X3 PACKAGE (RD4)

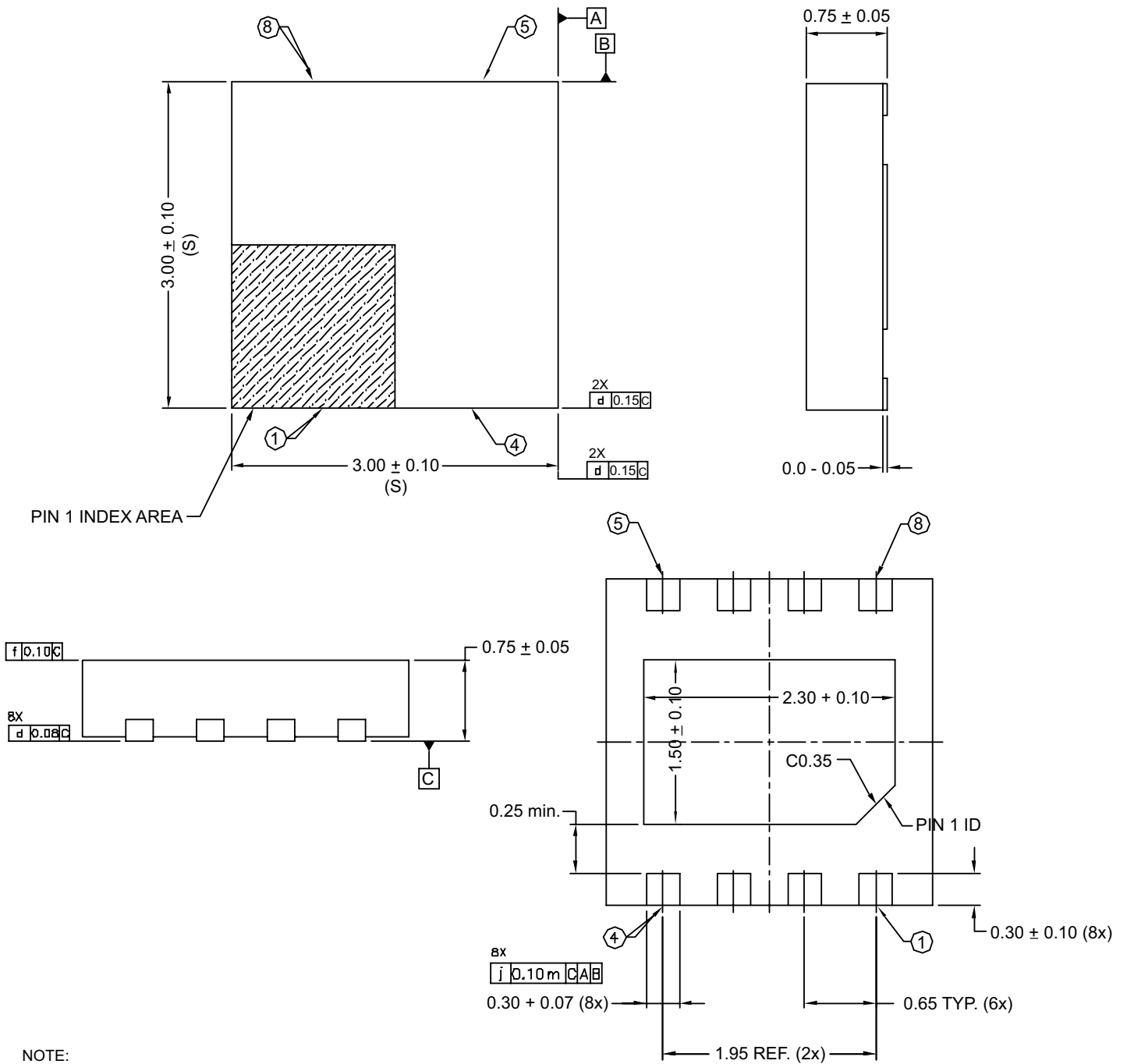

NOTE:

1. ALL DIMENSION ARE IN mm. ANGLES IN DEGREES.
2. COPLANARITY SHALL NOT EXCEED 0.08 mm.
3. WARPAGE SHALL NOT EXCEED 0.10 mm.
4. PACKAGE LENGTH / PACKAGE WIDTH ARE CONSIDERED AS SPECIAL CHARACTERISTIC(S)
5. REFER JEDEC MO-229 / WEEC

REVISION HISTORY

Date	Rev.	Reason
12/15/03	K	Updated typical thermal characteristics legend
1/9/2004	L	Updated typ/max figures for Electrical Specifications Updated Typical Characteristics plots (all except Efficiency vs. Load Current)
2/12/2004	M	Removed all references to TDFN (3x4.9mm) package Updated Typical Characteristics plots
2/24/2004	N	Updated Electrical Specifications table
5/5/2004	O	Updated Description Updated Typical Application figures Updated Ordering Information Updated Electrical Characteristics Removed sections under Device Operations Removed TDFN 3x4.9 package drawing
6/17/2004	P	Updated Efficiency vs. Load Current graph on page 4
9/3/2004	Q	Updated Ordering Information

Copyrights, Trademarks and Patents

Trademarks and registered trademarks of Catalyst Semiconductor include each of the following:

DPP™ AE²™

Catalyst Semiconductor has been issued U.S. and foreign patents and has patent applications pending that protect its products. For a complete list of patents issued to Catalyst Semiconductor contact the Company's corporate office at 408.542.1000.

CATALYST SEMICONDUCTOR MAKES NO WARRANTY, REPRESENTATION OR GUARANTEE, EXPRESS OR IMPLIED, REGARDING THE SUITABILITY OF ITS PRODUCTS FOR ANY PARTICULAR PURPOSE, NOR THAT THE USE OF ITS PRODUCTS WILL NOT INFRINGE ITS INTELLECTUAL PROPERTY RIGHTS OR THE RIGHTS OF THIRD PARTIES WITH RESPECT TO ANY PARTICULAR USE OR APPLICATION AND SPECIFICALLY DISCLAIMS ANY AND ALL LIABILITY ARISING OUT OF ANY SUCH USE OR APPLICATION, INCLUDING BUT NOT LIMITED TO, CONSEQUENTIAL OR INCIDENTAL DAMAGES.

Catalyst Semiconductor products are not designed, intended, or authorized for use as components in systems intended for surgical implant into the body, or other applications intended to support or sustain life, or for any other application in which the failure of the Catalyst Semiconductor product could create a situation where personal injury or death may occur.

Catalyst Semiconductor reserves the right to make changes to or discontinue any product or service described herein without notice. Products with data sheets labeled "Advance Information" or "Preliminary" and other products described herein may not be in production or offered for sale.

Catalyst Semiconductor advises customers to obtain the current version of the relevant product information before placing orders. Circuit diagrams illustrate typical semiconductor applications and may not be complete.



CATALYST

Catalyst Semiconductor, Inc.
Corporate Headquarters
1250 Borregas Avenue
Sunnyvale, CA 94089
Phone: 408.542.1000
Fax: 408.542.1200
www.catalyst-semiconductor.com

Publication #: 5002
Revision: Q
Issue date: 9/3/04