

Terminal Voltage $\pm 5V$, 100 Taps

X9C102/103/104/503

E²POT™ Nonvolatile Digital Potentiometer

FEATURES

- Compatible with X9102/103/104/503
- Low Power CMOS
 - $V_{CC} = 5V$
 - Active Current, 3mA Max
 - Standby Current, 500 μA Max
- 99 Resistive Elements
 - Temperature Compensated
 - $\pm 20\%$ End to End Resistance Range
- 100 Wiper Tap Points
 - Wiper Positioned via Three-Wire Interface
 - Similar to TTL Up/Down Counter
 - Wiper Position Stored in Nonvolatile Memory and Recalled on Power-Up
- 100 Year Wiper Position Data Retention
- X9C102 = 1K Ω
- X9C103 = 10K Ω
- X9C503 = 50K Ω
- X9C104 = 100K Ω

DESCRIPTION

The Xicor X9C102/103/104/503 is a solid state nonvolatile potentiometer and is ideal for digitally controlled resistance trimming.

The X9C102/103/104/503 is a resistor array composed of 99 resistive elements. Between each element and at either end are tap points accessible to the wiper element. The position of the wiper element is controlled by the \overline{CS} , U/\overline{D} , and \overline{INC} inputs. The position of the wiper can be stored in nonvolatile memory and then be recalled upon a subsequent power-up operation.

The resolution of the X9C102/103/104/503 is equal to the maximum resistance value divided by 99. As an example, for the X9C503 (50K Ω) each tap point represents 505 Ω .

All Xicor nonvolatile memories are designed and tested for applications requiring extended endurance and data retention.

FUNCTIONAL DIAGRAM

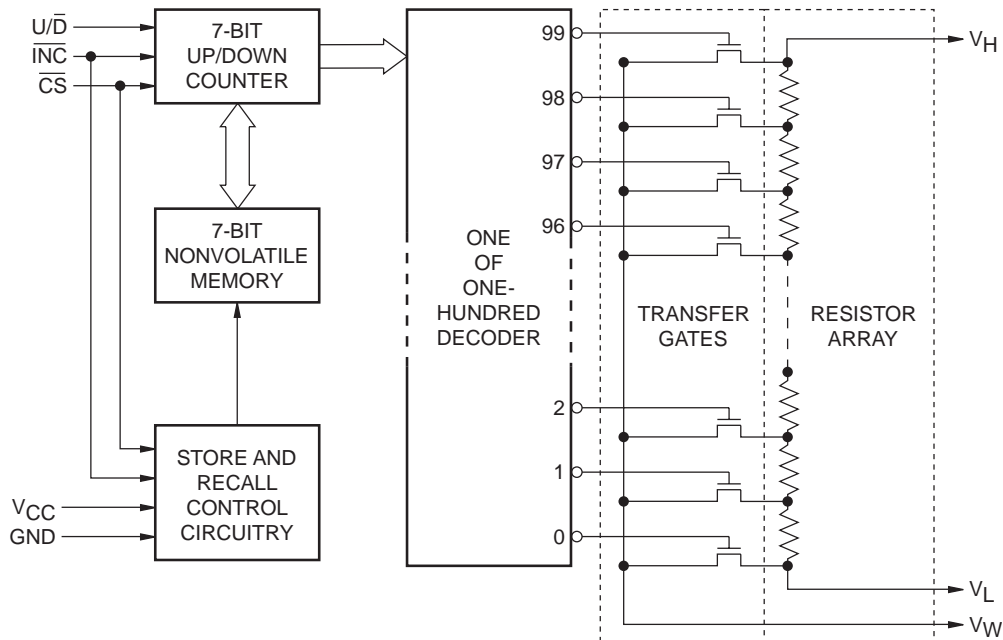

3863 FHD F01

X9C102/103/104/503

PIN DESCRIPTIONS

V_H and V_L

The high (V_H) and low (V_L) terminals of the X9C102/103/104/503 are equivalent to the fixed terminals of a mechanical potentiometer. The minimum voltage is $-5V$ and the maximum is $+5V$. It should be noted that the terminology of V_L and V_H references the relative position of the terminal in relation to wiper movement direction selected by the U/\bar{D} input and not the voltage potential on the terminal.

V_W

V_W is the wiper terminal, equivalent to the movable terminal of a mechanical potentiometer. The position of the wiper within the array is determined by the control inputs. The wiper terminal series resistance is typically 40Ω .

Up/Down (U/\bar{D})

The U/\bar{D} input controls the direction of the wiper movement and whether the counter is incremented or decremented.

Increment (\bar{INC})

The \bar{INC} input is negative-edge triggered. Toggling \bar{INC} will move the wiper and either increment or decrement the counter in the direction indicated by the logic level on the U/\bar{D} input.

Chip Select (\bar{CS})

The device is selected when the \bar{CS} input is LOW. The current counter value is stored in nonvolatile memory when \bar{CS} is returned HIGH while the \bar{INC} input is also HIGH. After the store operation is complete the X9C102/103/104/503 will be placed in the low power standby mode until the device is selected once again.

PIN CONFIGURATION

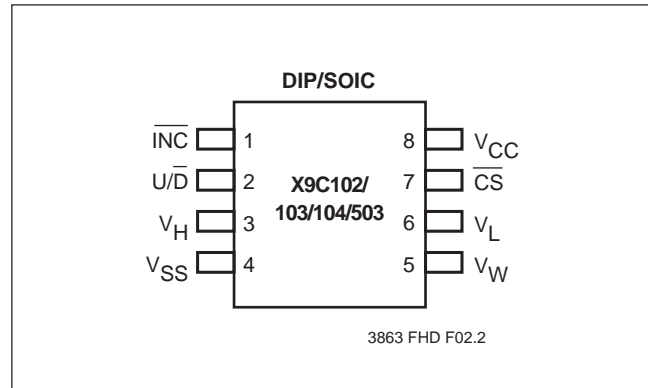

PIN NAMES

Symbol	Description
V_H	High Terminal
V_W	Wiper Terminal
V_L	Low Terminal
V_{SS}	Ground
V_{CC}	Supply Voltage
U/\bar{D}	Up/Down Input
\bar{INC}	Increment Input
\bar{CS}	Chip Select Input
NC	No Connect

3863 PGM T01

X9C102/103/104/503

DEVICE OPERATION

There are three sections of the X9C102/103/104/503: the input control, counter and decode section; the non-volatile memory; and the resistor array. The input control section operates just like an up/down counter. The output of this counter is decoded to turn on a single electronic switch connecting a point on the resistor array to the wiper output. Under the proper conditions the contents of the counter can be stored in nonvolatile memory and retained for future use. The resistor array is comprised of 99 individual resistors connected in series. At either end of the array and between each resistor is an electronic switch that transfers the potential at that point to the wiper.

The \overline{INC} , U/\overline{D} and \overline{CS} inputs control the movement of the wiper along the resistor array. With \overline{CS} set LOW the X9C102/103/104/503 is selected and enabled to respond to the U/\overline{D} and \overline{INC} inputs. HIGH to LOW transitions on \overline{INC} will increment or decrement (depending on the state of the U/\overline{D} input) a seven-bit counter. The output of this counter is decoded to select one of one-hundred wiper positions along the resistive array.

The wiper, when at either fixed terminal, acts like its mechanical equivalent and does not move beyond the last position. That is, the counter does not wrap around when clocked to either extreme.

The value of the counter is stored in nonvolatile memory whenever \overline{CS} transitions HIGH while the \overline{INC} input is also HIGH.

When the X9C102/103/104/503 is powered-down, the last counter position stored will be maintained in the nonvolatile memory. When power is restored, the contents of the memory are recalled and the counter is reset to the value last stored.

OPERATION NOTES

The system may select the X9C102/103/104/503, move the wiper, and deselect the device without having to store the latest wiper, position in nonvolatile memory. The wiper movement is performed as described above; once the new position is reached, the system would keep \overline{INC} LOW while taking \overline{CS} HIGH. The new wiper position would be maintained until changed by the system or until a power-down/up cycle recalled the previously stored data.

This would allow the system to always power-up to a preset value stored in nonvolatile memory; then during system operation minor adjustments could be made. The adjustments might be based on user preference: system parameter changes due to temperature drift, etc...

The state of U/\overline{D} may be changed while \overline{CS} remains LOW. This allows the host system to enable the X9C102/103/104/503 and then move the wiper up and down until the proper trim is attained.





T_{IW}/R_{TOTAL}

The electronic switches on the X9C102/103/104/503 operate in a “make before break” mode when the wiper changes tap positions. If the wiper is moved several positions, multiple taps are connected to the wiper for t_{IW} (\overline{INC} to V_W change). The R_{TOTAL} value for the device can temporarily be reduced by a significant amount if the wiper is moved several positions.

R_{TOTAL} with V_{CC} Removed

The end to end resistance of the array will fluctuate once V_{CC} is removed.

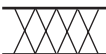
SYMBOL TABLE

WAVEFORM	INPUTS	OUTPUTS
	Must be steady	Will be steady
	May change from LOW to HIGH	Will change from LOW to HIGH
	May change from HIGH to LOW	Will change from HIGH to LOW
	Don't Care: Changes Allowed	Changing: State Not Known
	N/A	Center Line is High Impedance

X9C102/103/104/503

ABSOLUTE MAXIMUM RATINGS*

Temperature under Bias	-65°C to +135°C
Storage Temperature	-65°C to +150°C
Voltage on \overline{CS} , \overline{INC} , U/\overline{D} and V_{CC} with Respect to V_{SS}	-1V to +7V
Voltage on V_H and V_L Referenced to V_{SS}	-8V to +8V
$\Delta V = V_H - V_L $ X9C102	4V
X9C103, X9C503, and X9C104	10V
Lead Temperature (Soldering, 10 seconds)	+300°C
Wiper Current	± 1 mA

ANALOG CHARACTERISTICS

Electrical Characteristics

End-to-End Resistance Tolerance	$\pm 20\%$
Power Rating at 25°C	
X9C102	16mW
X9C103, X9C503, and X9C104	10mW
Wiper Current	± 1 mA Max.
Typical Wiper Resistance	40 Ω at 1mA
Typical Noise	< -120dB/ $\sqrt{\text{Hz}}$ Ref: 1V

Resolution

Resistance	1%
------------------	----

Linearity

Absolute Linearity ⁽¹⁾	± 1.0 MI ⁽²⁾
Relative Linearity ⁽³⁾	± 0.2 MI ⁽²⁾

Test Circuit #1

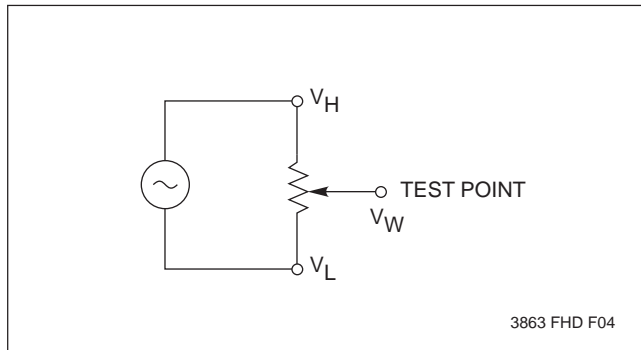

- Notes:** (1) Absolute Linearity is utilized to determine actual wiper voltage versus expected voltage = $(V_{w(n)}(\text{actual}) - V_{w(n)}(\text{expected})) = \pm 1$ MI Maximum.
 (2) 1 MI = Minimum Increment = $R_{TOT}/99$.
 (3) Relative Linearity is a measure of the error in step size between taps = $V_{w(n+1)} - [V_{w(n)} + \text{MI}] = +0.2$ MI.

*COMMENT

Stresses above those listed under “Absolute Maximum Ratings” may cause permanent damage to the device. This is a stress rating only and the functional operation of the device at these or any other conditions above those listed in the operational sections of this specification is not implied. Exposure to absolute maximum rating conditions for extended periods may affect device reliability.

Temperature Coefficient

(-40°C to +85°C)	
X9C102	+600 ppm/°C Typical
X9C103, X9C503, X9C104	+300 ppm/°C Typical
Ratiometric Temperature Coefficient	± 20 ppm

Wiper Adjustability

Unlimited Wiper Adjustment (Non-Store operation)	
Wiper Position Store Operations	10,000 Data Changes

Physical Characteristics

Marking Includes

- Manufacturer’s Trademark
- Resistance Value or Code
- Date Code

Test Circuit #2

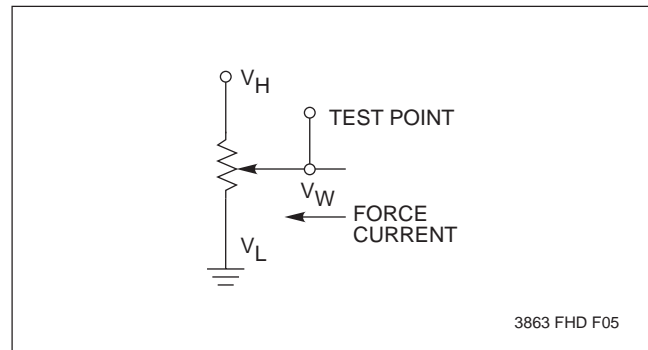

X9C102/103/104/503

RECOMMENDED OPERATING CONDITIONS

Temperature	Min.	Max.
Commercial	0°C	+70°C
Industrial	-40°C	+85°C
Military	-55°C	+125°C

3863 PGM T03.1

Supply Voltage	Limits
X9C102/103/104/503	5V ±10%

3863 PGM T04.2

D.C. OPERATING CHARACTERISTICS (Over recommended operating conditions unless otherwise specified.)

Symbol	Parameter	Limits			Units	Test Conditions
		Min.	Typ. ⁽⁴⁾	Max.		
I _{CC}	V _{CC} Active Current		1	3	mA	$\overline{CS} = V_{IL}$, $U/\overline{D} = V_{IL}$ or V_{IH} and $\overline{INC} = 0.4V$ to $2.4V$ @ max. t_{CYC}
I _{SB}	Standby Supply Current		200	500	μA	$\overline{CS} = V_{CC} - 0.3V$, U/\overline{D} and $\overline{INC} = V_{SS}$ or $V_{CC} - 0.3V$
I _{LI}	\overline{CS} , \overline{INC} , U/\overline{D} Input Leakage Current			±10	μA	$V_{IN} = V_{SS}$ to V_{CC}
V _{IH}	\overline{CS} , \overline{INC} , U/\overline{D} Input HIGH Voltage	2		V _{CC} + 1	V	
V _{IL}	\overline{CS} , \overline{INC} , U/\overline{D} Input LOW Voltage	-1		0.8	V	
R _W	Wiper Resistance		40	100	Ω	Max. Wiper Current ±1mA
V _H	VH Terminal Voltage	-5		+5	V	
V _L	VL Terminal Voltage	-5		+5	V	
C _{IN} ⁽⁵⁾	\overline{CS} , \overline{INC} , U/\overline{D} Input Capacitance			10	pF	$V_{CC} = 5V$, $V_{IN} = V_{SS}$, $T_A = 25^\circ C$, $f = 1MHz$

3863 PGM T05.3

STANDARD PARTS

Part Number	Maximum Resistance	Wiper Increments	Minimum Resistance
X9C102	1KΩ	10.1Ω	40Ω
X9C103	10KΩ	101Ω	40Ω
X9C503	50KΩ	505Ω	40Ω
X9C104	100KΩ	1010Ω	40Ω

3863 PGM T08.1

- Notes:** (4) Typical values are for $T_A = 25^\circ C$ and nominal supply voltage.
 (5) This parameter is periodically sampled and not 100% tested.

X9C102/103/104/503

A.C. CONDITIONS OF TEST

Input Pulse Levels	0V to 3V
Input Rise and Fall Times	10ns
Input Reference Levels	1.5V

3863 PGM T05.1

MODE SELECTION

\overline{CS}	\overline{INC}	U/\overline{D}	Mode
L	λ	H	Wiper Up
L	λ	L	Wiper Down
f	H	X	Store Wiper Position
H	X	X	Standby Current
f	L	X	No Store, Return to Standby

3863 PGM T06

A.C. OPERATING CHARACTERISTICS (Over recommended operating conditions unless otherwise specified)

Symbol	Parameter	Limits			Units
		Min.	Typ.(6)	Max.	
t_{CI}	\overline{CS} to \overline{INC} Setup	100			ns
t_{ID}	\overline{INC} HIGH to U/\overline{D} Change	100			ns
t_{DI}	U/\overline{D} to \overline{INC} Setup	2.9			μ s
t_{IL}	\overline{INC} LOW Period	1			μ s
t_{IH}	\overline{INC} HIGH Period	1			μ s
t_{IC}	\overline{INC} Inactive to \overline{CS} Inactive	1			μ s
t_{CPH}	\overline{CS} Deselect Time	20			ms
t_{IW}	\overline{INC} to V_W Change		100	500	μ s
t_{CYC}	\overline{INC} Cycle Time	4			μ s
$t_R, t_F^{(7)}$	\overline{INC} Input Rise and Fall Time			500	μ s
$t_{PU}^{(7)}$	Power up to Wiper Stable			500	μ s
$t_R V_{CC}^{(7)}$	V_{CC} Power-up Rate	0.2		50	mV/ μ s

3863 PGM T07.3

A.C. Timing

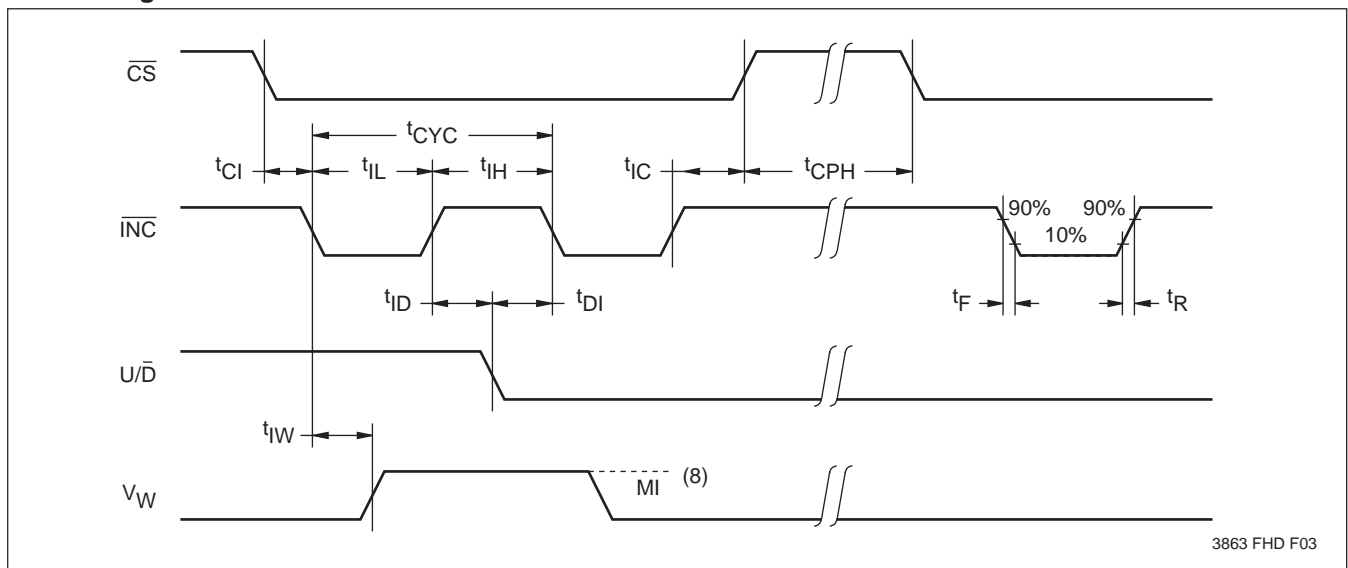

3863 FHD F03

- Notes:** (6) Typical values are for $T_A = 25^\circ\text{C}$ and nominal supply voltage.
 (7) This parameter is periodically sampled and not 100% tested.
 (8) MI in the A.C. timing diagram refers to the minimum incremental change in the V_W output due to a change in the wiper position.

X9C102/103/104/503

Typical Frequency Response for X9C102

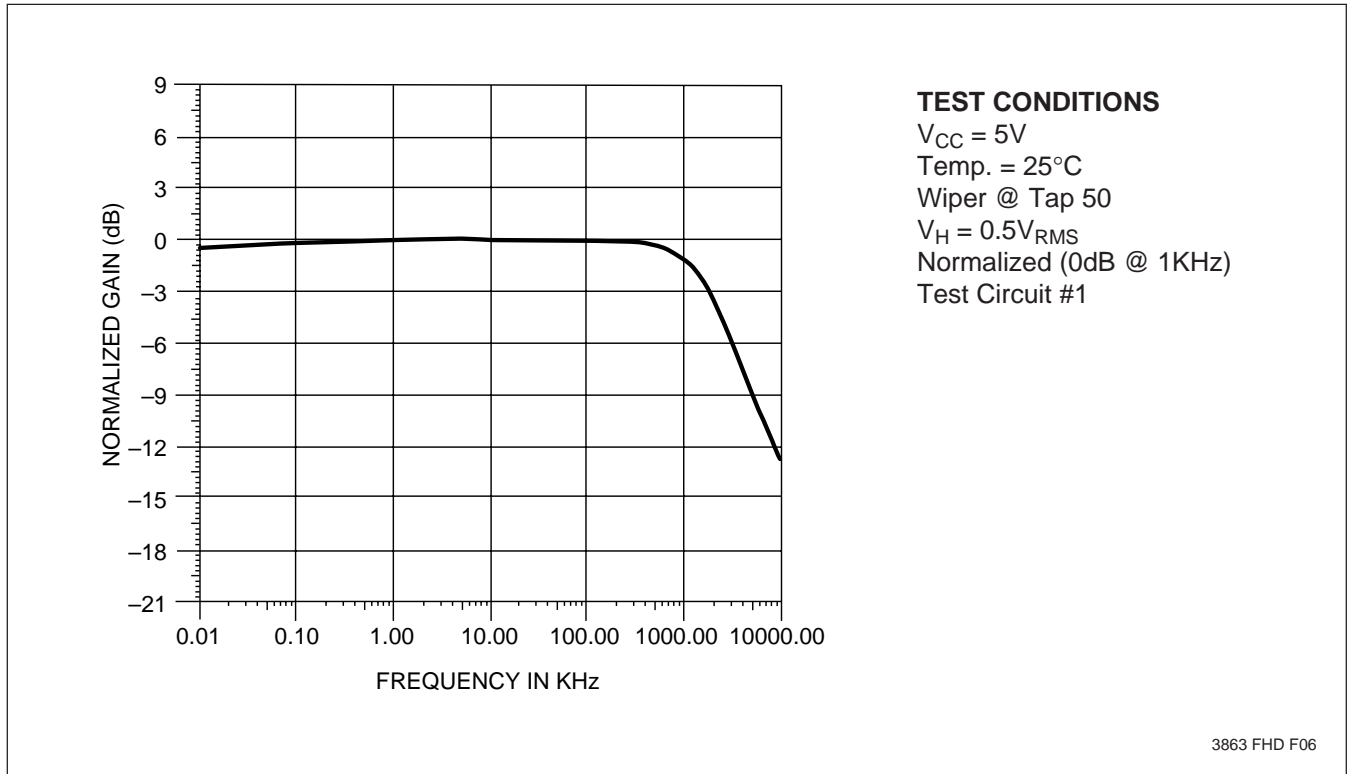

Typical Total Harmonic Distortion for X9C102

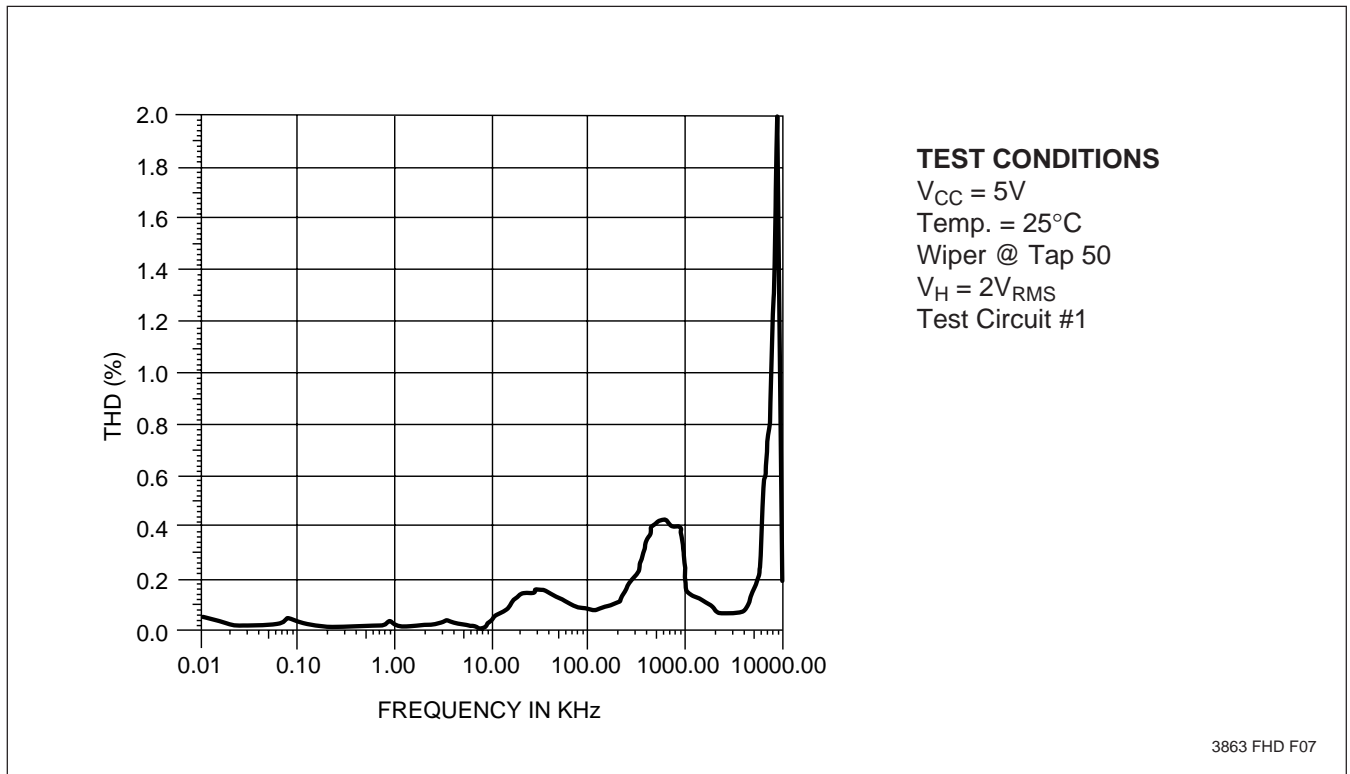

X9C102/103/104/503

Typical Linearity for X9C102

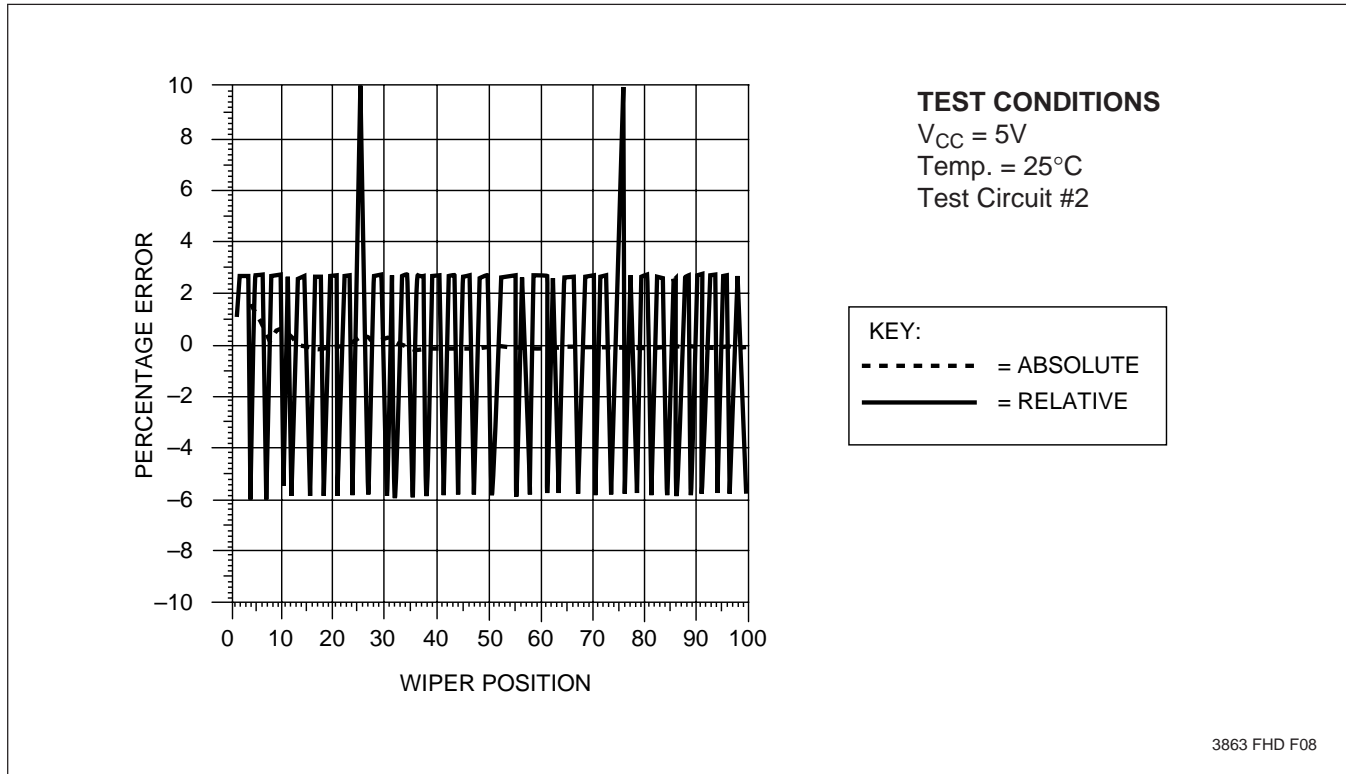

Typical Frequency Response for X9C103

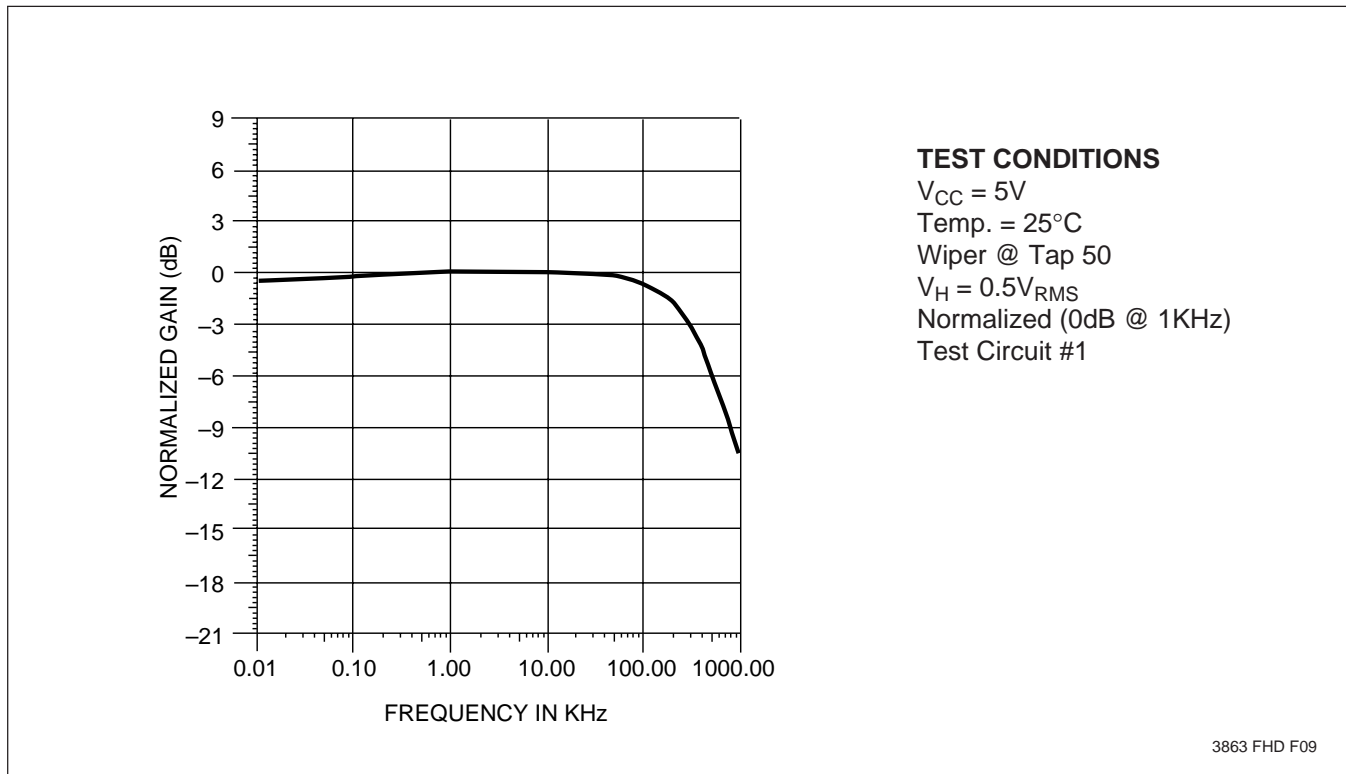

X9C102/103/104/503

Typical Total Harmonic Distortion for X9C103

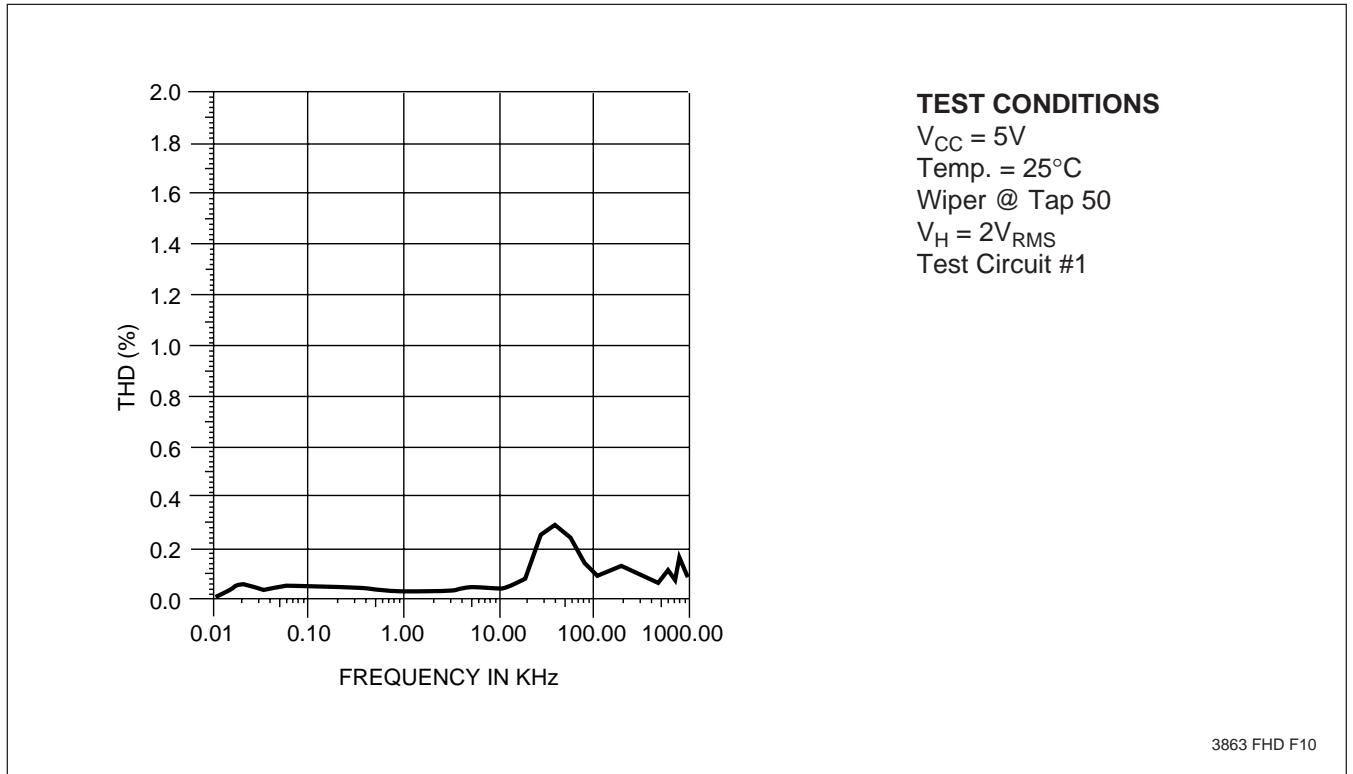

Typical Linearity for X9C103

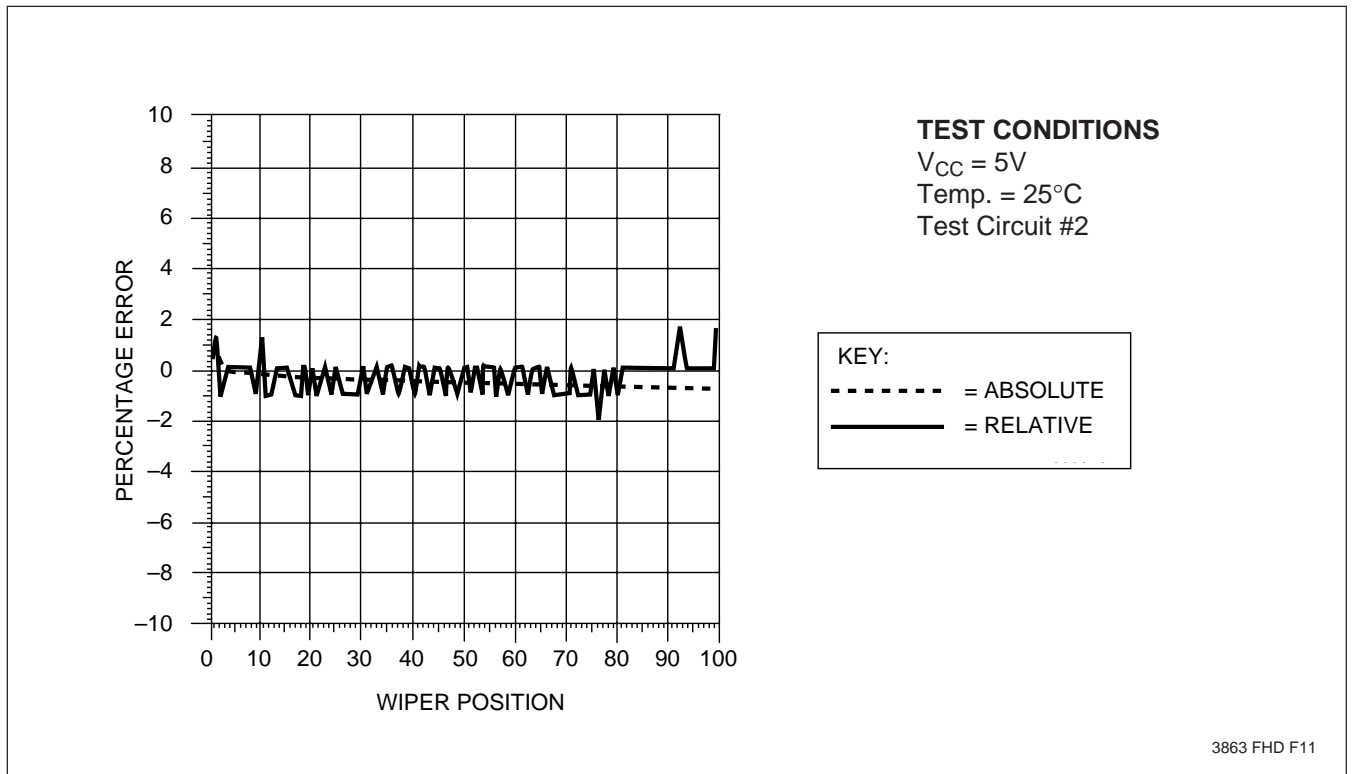

X9C102/103/104/503

Typical Frequency Response for X9C503

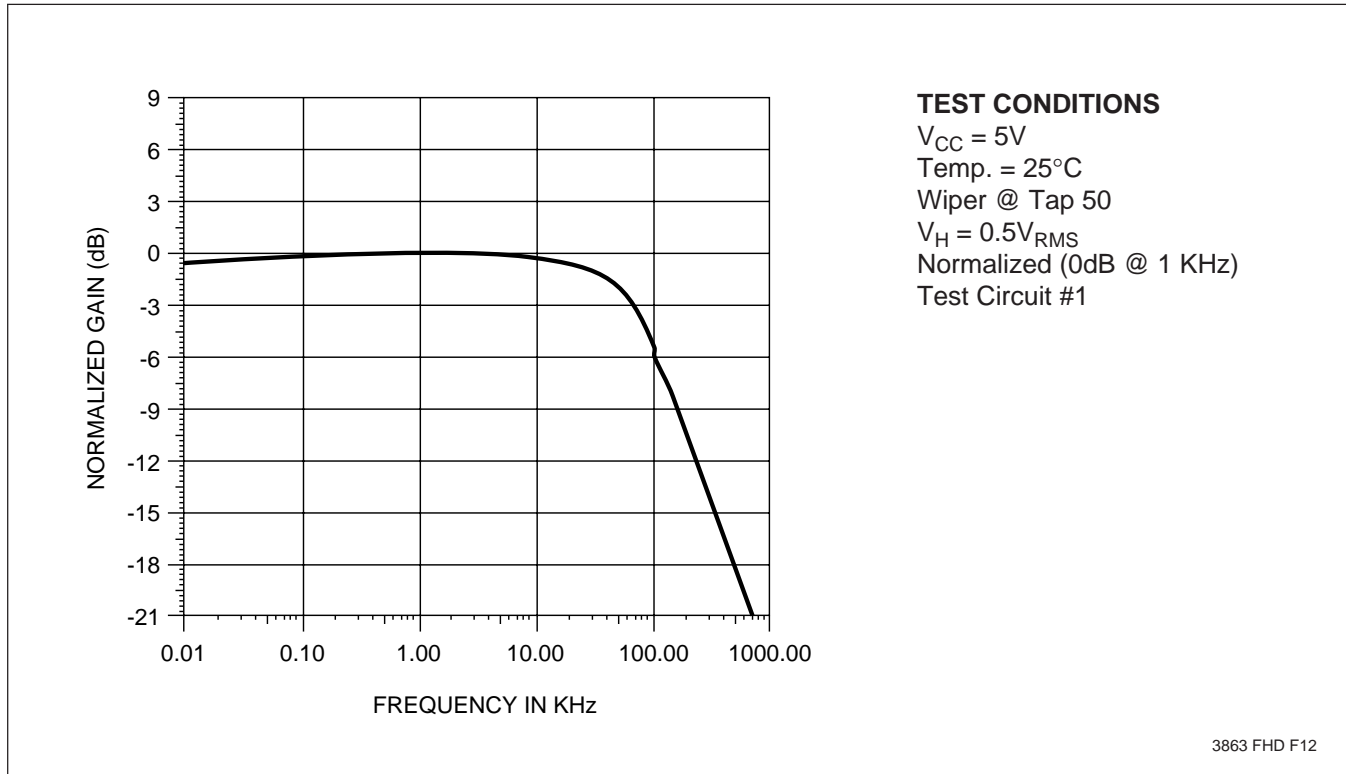

Typical Total Harmonic Distortion for X9C503

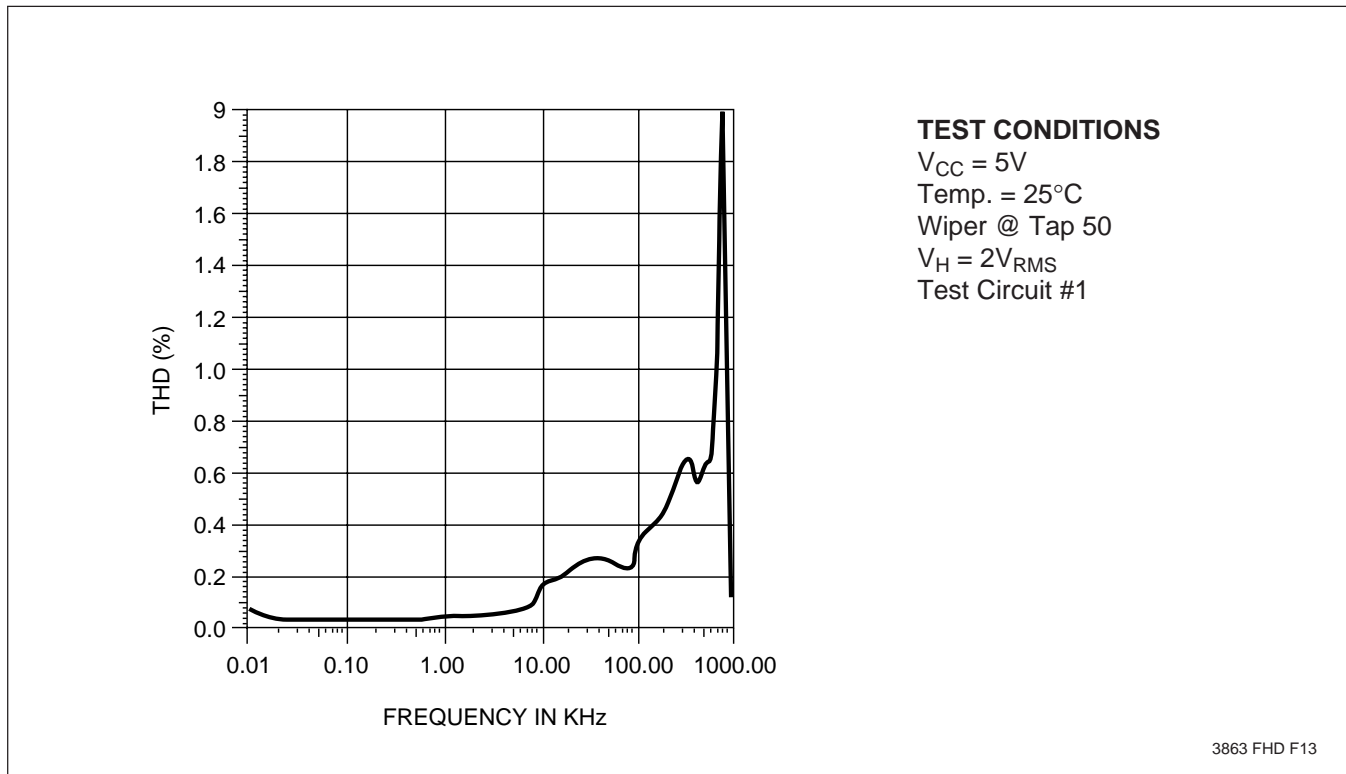

X9C102/103/104/503

Typical Linearity for X9C503

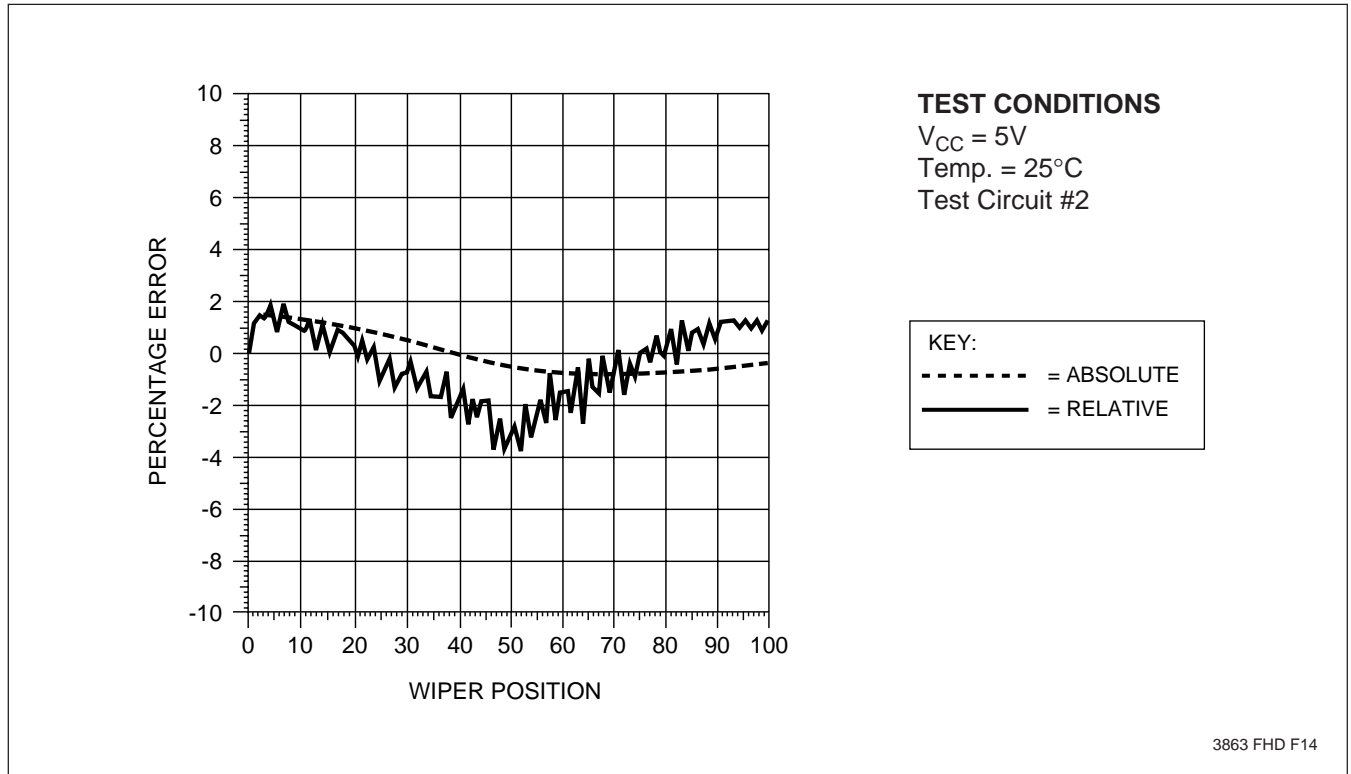

Typical Frequency Response for X9C104

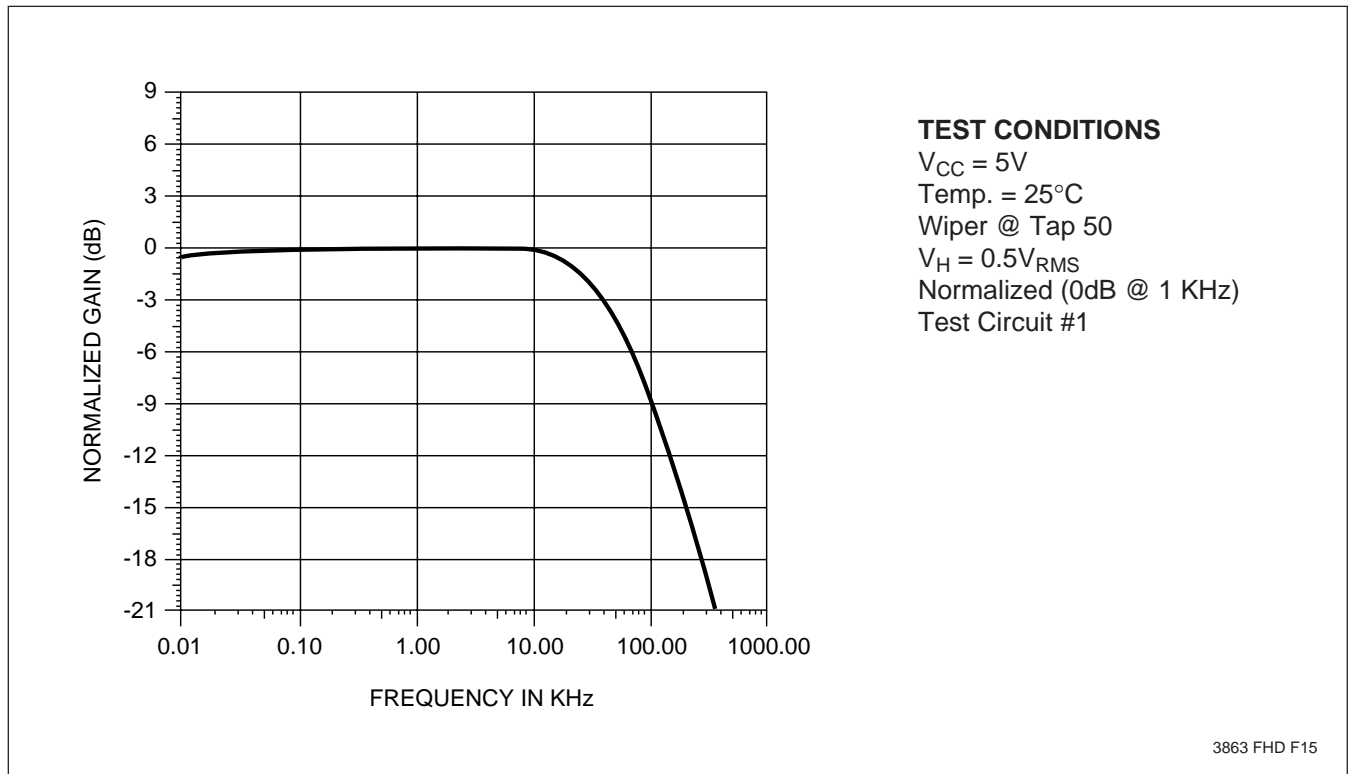

X9C102/103/104/503

Typical Total Harmonic Distortion for X9C104

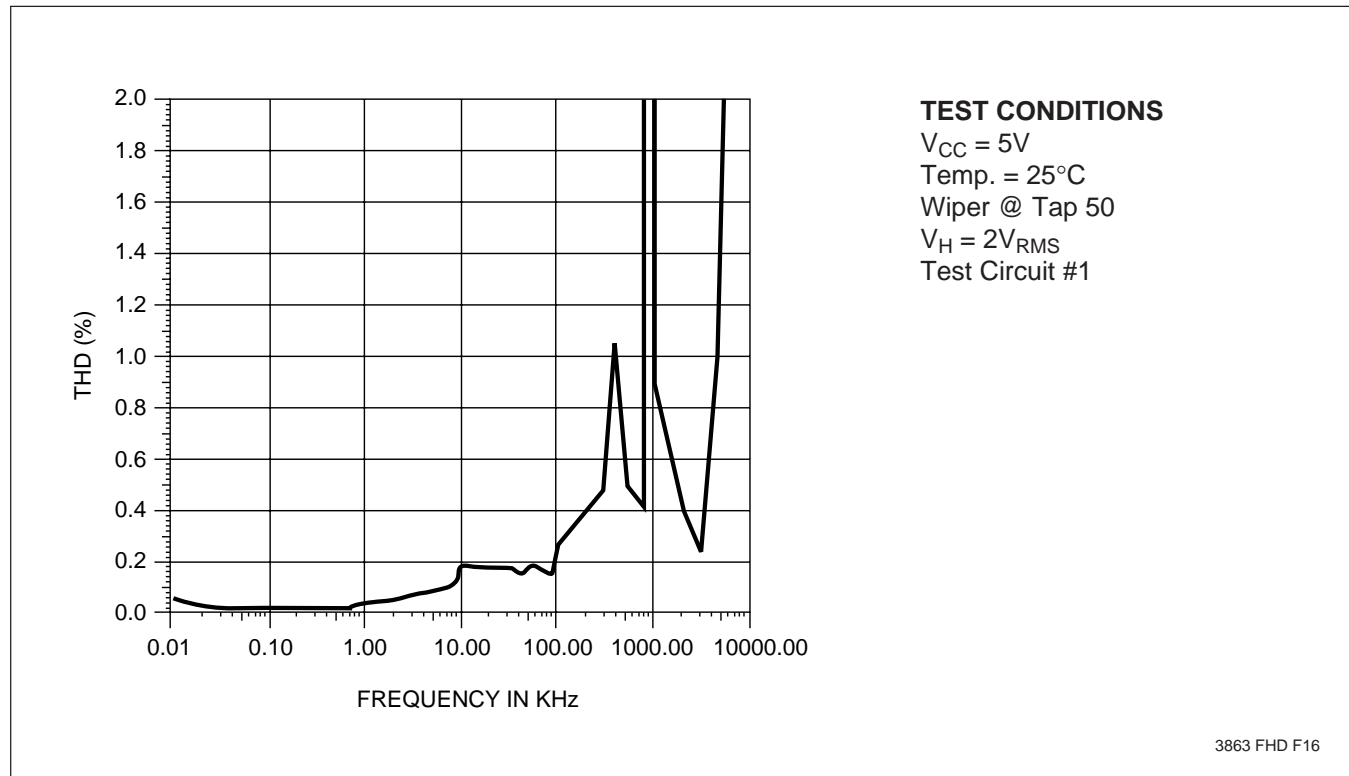

Typical Linearity for X9C104

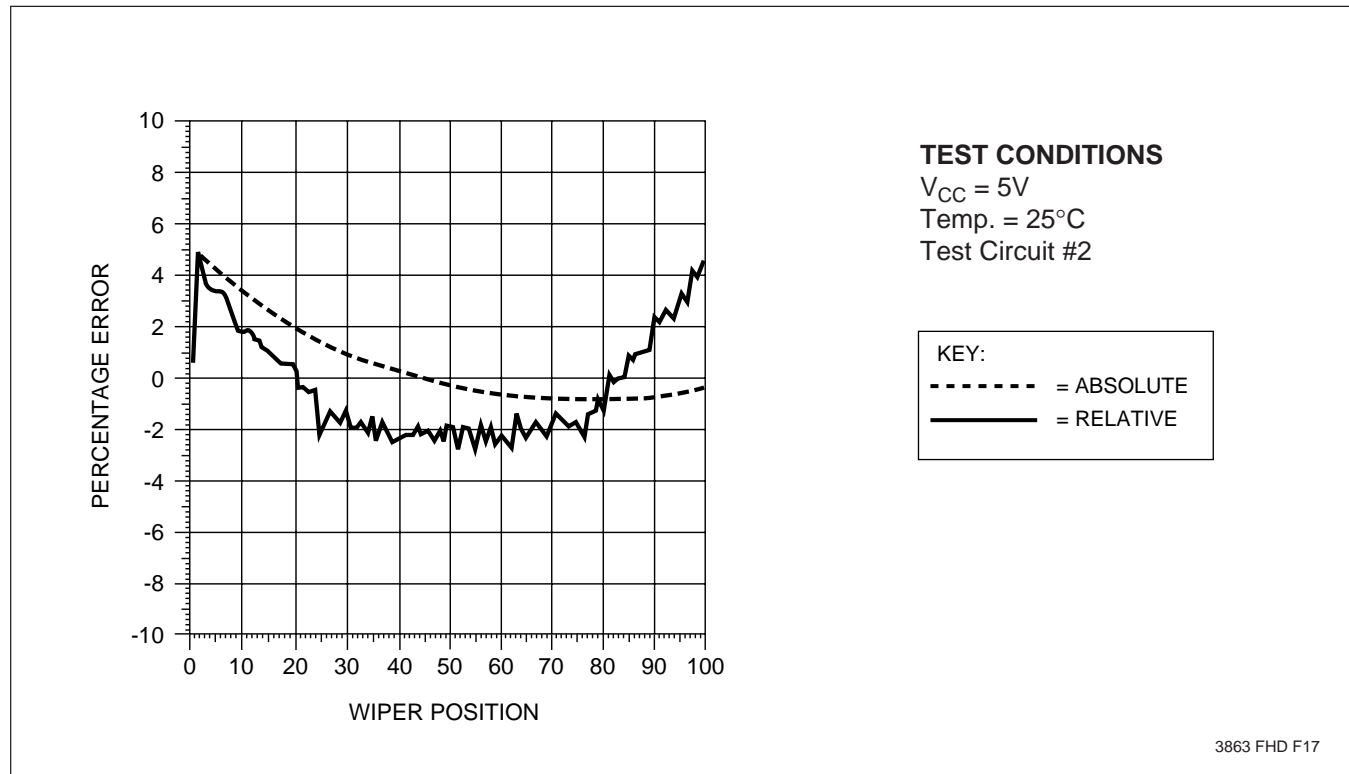

X9C102/103/104/503

PACKAGING INFORMATION

8-LEAD PLASTIC DUAL IN-LINE PACKAGE TYPE P

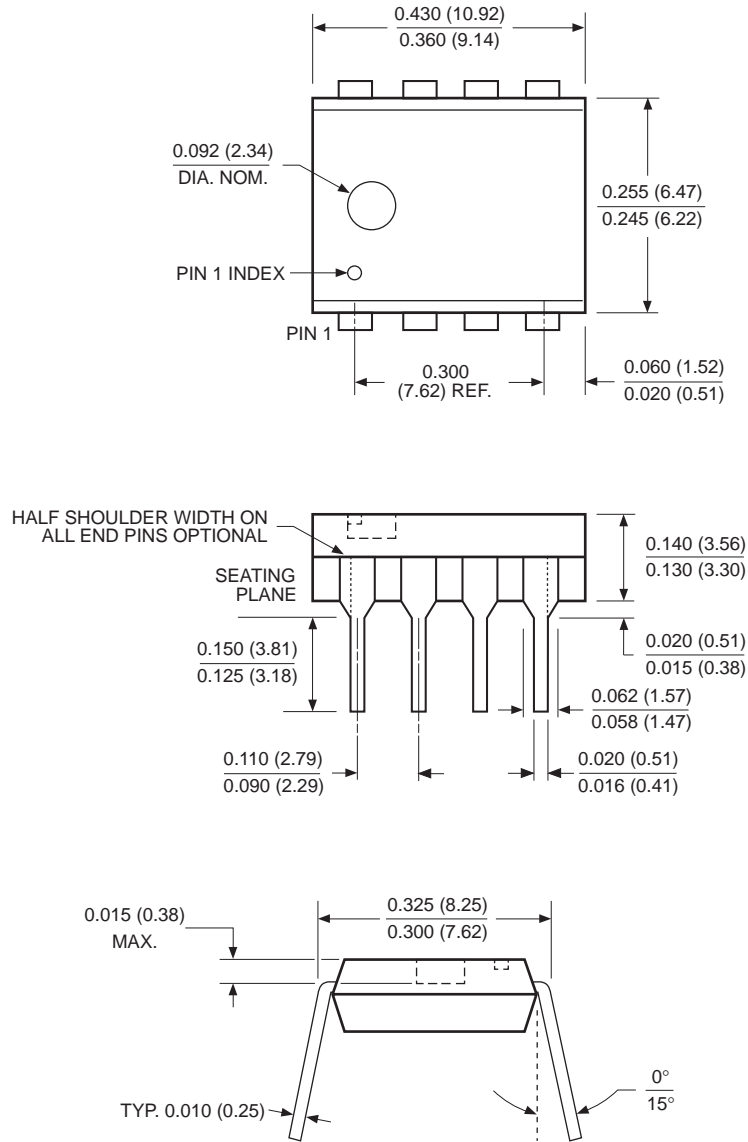

NOTE: ALL DIMENSIONS IN INCHES (IN PARENTHESES IN MILLIMETERS)

3926 FHD F01

X9C102/103/104/503

PACKAGING INFORMATION

8-LEAD PLASTIC SMALL OUTLINE GULL WING PACKAGE TYPE S

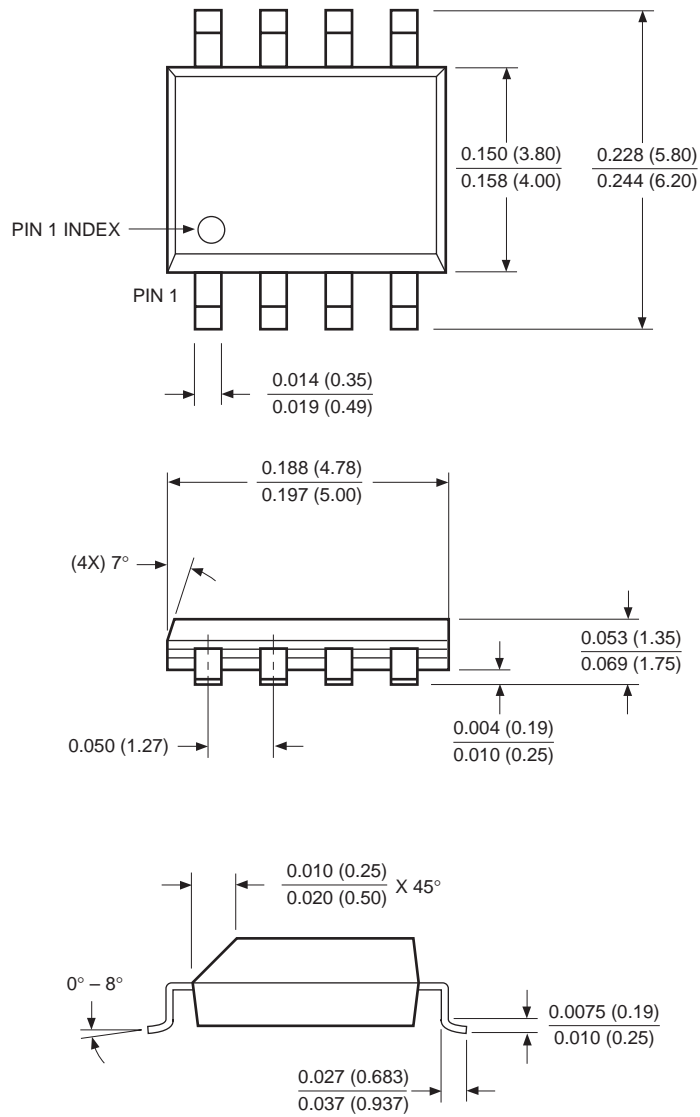

NOTE: ALL DIMENSIONS IN INCHES (IN PARENTHESIS IN MILLIMETERS)

3926 FHD F22

X9C102/103/104/503

ORDERING INFORMATION

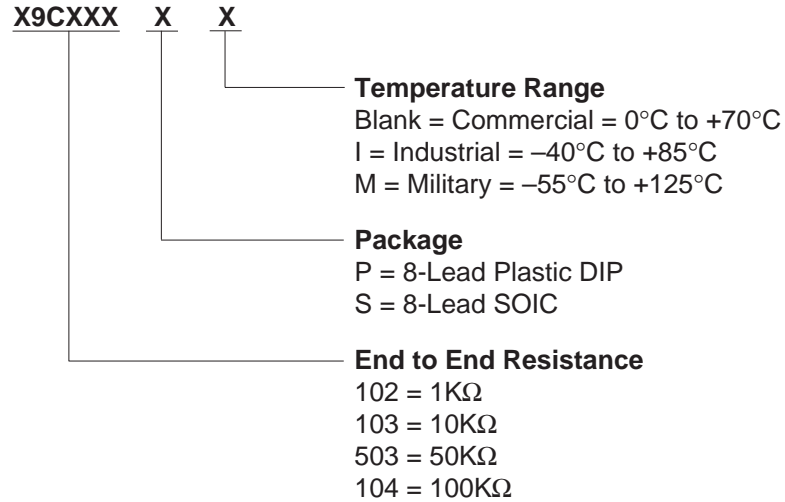

LIMITED WARRANTY

Devices sold by Xicor, Inc. are covered by the warranty and patent indemnification provisions appearing in its Terms of Sale only. Xicor, Inc. makes no warranty, express, statutory, implied, or by description regarding the information set forth herein or regarding the freedom of the described devices from patent infringement. Xicor, Inc. makes no warranty of merchantability or fitness for any purpose. Xicor, Inc. reserves the right to discontinue production and change specifications and prices at any time and without notice.

Xicor, Inc. assumes no responsibility for the use of any circuitry other than circuitry embodied in a Xicor, Inc. product. No other circuits, patents, licenses are implied.

U.S. PATENTS

Xicor products are covered by one or more of the following U.S. Patents: 4,263,664; 4,274,012; 4,300,212; 4,314,265; 4,326,134; 4,393,481; 4,404,475; 4,450,402; 4,486,769; 4,488,060; 4,520,461; 4,533,846; 4,599,706; 4,617,652; 4,668,932; 4,752,912; 4,829,482; 4,874,967; 4,883,976. Foreign patents and additional patents pending.

LIFE RELATED POLICY

In situations where semiconductor component failure may endanger life, system designers using this product should design the system with appropriate error detection and correction, redundancy and back-up features to prevent such an occurrence.

Xicor's products are not authorized for use in critical components in life support devices or systems.

1. Life support devices or systems are devices or systems which, (a) are intended for surgical implant into the body, or (b) support or sustain life, and whose failure to perform, when properly used in accordance with instructions for use provided in the labeling, can be reasonably expected to result in a significant injury to the user.
2. A critical component is any component of a life support device or system whose failure to perform can be reasonably expected to cause the failure of the life support device or system, or to affect its safety or effectiveness.