



64K

XM20C64

8K x 8

High Speed AUTOSTORE™ NOVRAM

FEATURES

- **High Speed:** $t_{AA} = 55ns$
- **NO Batteries!!**
- **Low Power CMOS**
- **AUTOSTORE™ NOVRAM**
—Automatically Stores RAM data to E²PROM upon Power-fail Detection
- **Open Drain AUTOSTORE Output Pin**
—Provides Interrupt or Status Information
—Linkable to System Reset Circuitry
- **Auto Recall**
—Automatically Recalls E²PROM Data During Power-on
- **Fully Decoded Module**
- **Full Military Temperature Range**
— $-55^{\circ}C$ to $+125^{\circ}C$
- **High Reliability**
—Endurance: 1,000,000 Nonvolatile Store Cycles
—Data Retention: 100 Years
- **ESD Protection**
— $\geq 2KV$ All Pins
- **Also Available in 66 Pin PUMA Package**

DESCRIPTION

The XM20C64 is a high speed nonvolatile RAM Module. It is comprised of four Xicor X20C16 high speed NOVRAMs, a high speed decoder and decoupling capacitors mounted on a co-fired multilayered Ceramic substrate. The XM20C64 is configured 8K x 8 and is fully decoded. The module is a 28-lead DIP conforming to the industry standard pinout for SRAMs.

The XM20C64 fully supports the AUTOSTORE feature, providing hands-off automatic storing of RAM data into E²PROM when V_{CC} falls below the AUTOSTORE threshold.

The XM20C64 is a highly reliable memory component, supporting unlimited writes to RAM, a minimum 1,000,000 store cycles and a minimum 100 year data retention.

FUNCTIONAL DIAGRAM

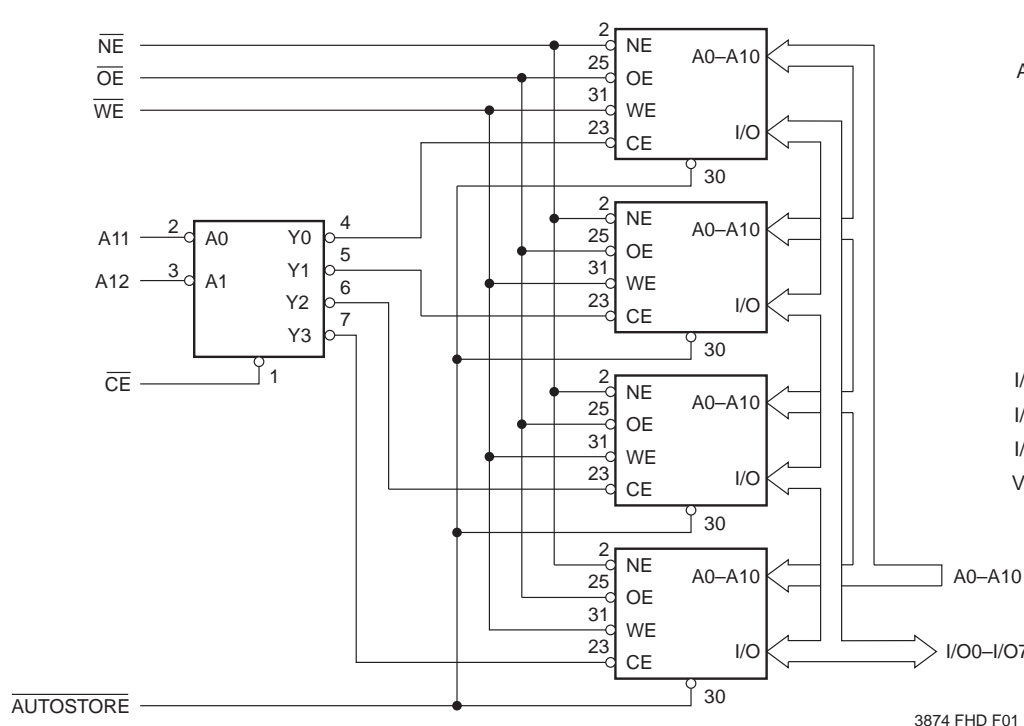

PIN CONFIGURATION

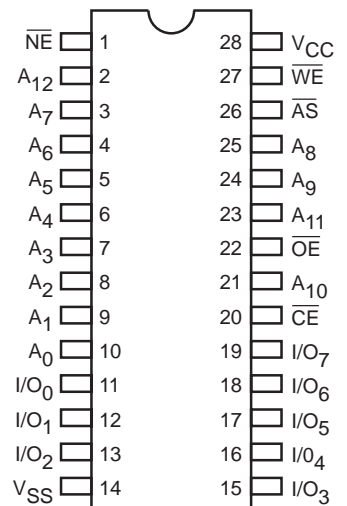

3874 FHD F02.1

3874 FHD F01

AUTOSTORE™ NOVRAM is a trademark of Xicor, Inc.

XM20C64

PIN DESCRIPTIONS

Addresses (A₀-A₁₂)

The address inputs select an 8-bit memory location during read and write operations.

Chip Enable (\overline{CE})

The chip enable input must be LOW to enable all read, write and user requested nonvolatile operations.

Output Enable (\overline{OE})

During normal RAM operations \overline{OE} controls the data output buffers. If a hardware nonvolatile operation is selected ($\overline{NE} = \overline{CE} = \text{LOW}$) and \overline{OE} strobes LOW, a recall operation will be initiated.

\overline{OE} LOW will always disable a STORE operation regardless of the state of \overline{NE} , \overline{WE} , and \overline{CE} so long as the internal transfer has not commenced.

Write Enable (\overline{WE})

During normal RAM operations $\overline{WE} = \overline{CE} = \text{LOW}$ will cause data to be written to the RAM address pointed to by the A₀-A₁₂ inputs.

Nonvolatile Enable (\overline{NE})

The nonvolatile input controls the transfer of data from the E²PROM array to the RAM array, when strobed LOW in conjunction with $\overline{CE} = \overline{OE} = \text{LOW}$.

Data In/Data Out (I/O₀-I/O₇)

Data is written to or read from the X20C64 through the I/O pins. The I/O pins are placed in the high impedance state when either \overline{CE} or \overline{OE} is HIGH or when \overline{NE} is LOW.

AUTOSTORE Output (\overline{AS})

\overline{AS} is an open-drain output. When it is asserted (driving LOW) it indicates V_{CC} has fallen below the AUTOSTORE threshold and an internal store operation has been initiated. Because \overline{AS} is an open drain output it may be wire-ORed with multiple open drain outputs and used as an interrupt input to a microprocessor.

DEVICE OPERATION

NOVRAM operations are identical to those of a standard SRAM. When \overline{OE} and \overline{CE} are asserted data is presented at the I/Os from the address location pointed to by the A₀-A₁₂ inputs.

RAM write operations are initiated and the address input is latched by the HIGH to LOW transition of \overline{CE} or \overline{WE} , whichever occurs last. Data is latched on the rising edge of either \overline{CE} or \overline{WE} , whichever occurs first.

An array recall, E²PROM data transferred to RAM, is initiated whenever $\overline{OE} = \overline{NE} = \overline{CE} = \text{LOW}$. A recall is also performed automatically upon power-up.

Command Sequence Operations

The X20C64 employs a version of the industry standard Software Data Protection (SDP). The end user can select various options for transferring data from RAM into the E²PROM array.

All command sequences are comprised of three specific data/address write operations performed with \overline{NE} LOW. A Store operation can be directly selected by issuing a Store command. The user may also enable and disable the AUTOSTORE function through the software data protection sequence. Refer to Table 1 below for a complete description of the command sequence.

Operational Notes

The X20C64 should be viewed as a subsystem when writing software for the various store operations. The module contains four discrete components each needing to be set to the required state individually. The two high order address bits (A₁₁ and A₁₂) select only one of the four components.

XM20C64

TABLE 1

Step	Operation	A ₀ –A ₁₀ *	Data Pattern
1	Write	555	AA
2	Write	2AA	55
3	Write	555	Command

3874 PGM T11

* It should be noted, the high order addresses should remain stable during the operations. It should also be noted that these commands are not global, that is only one device on the module will be affected by each command operation.

TABLE 2

Command	Function
CC[H]	Enable Autostore
CD[H]	Disable Autostore
33[H]	Store Operation

3874 PGM T12.2

Command Sequence Timing Limits

Symbol	Parameter	Limits		Units
		Min.	Max.	
t _{STO}	Store Time		5	ms
t _{SP}	Command Write Pulse Width	50		ns
t _{SPH}	Inter Command Delay	55		ns

Note: All Write Command Sequence timings must conform to the standard write timing requirements.

3874 PGM T01.1

Command Sequence

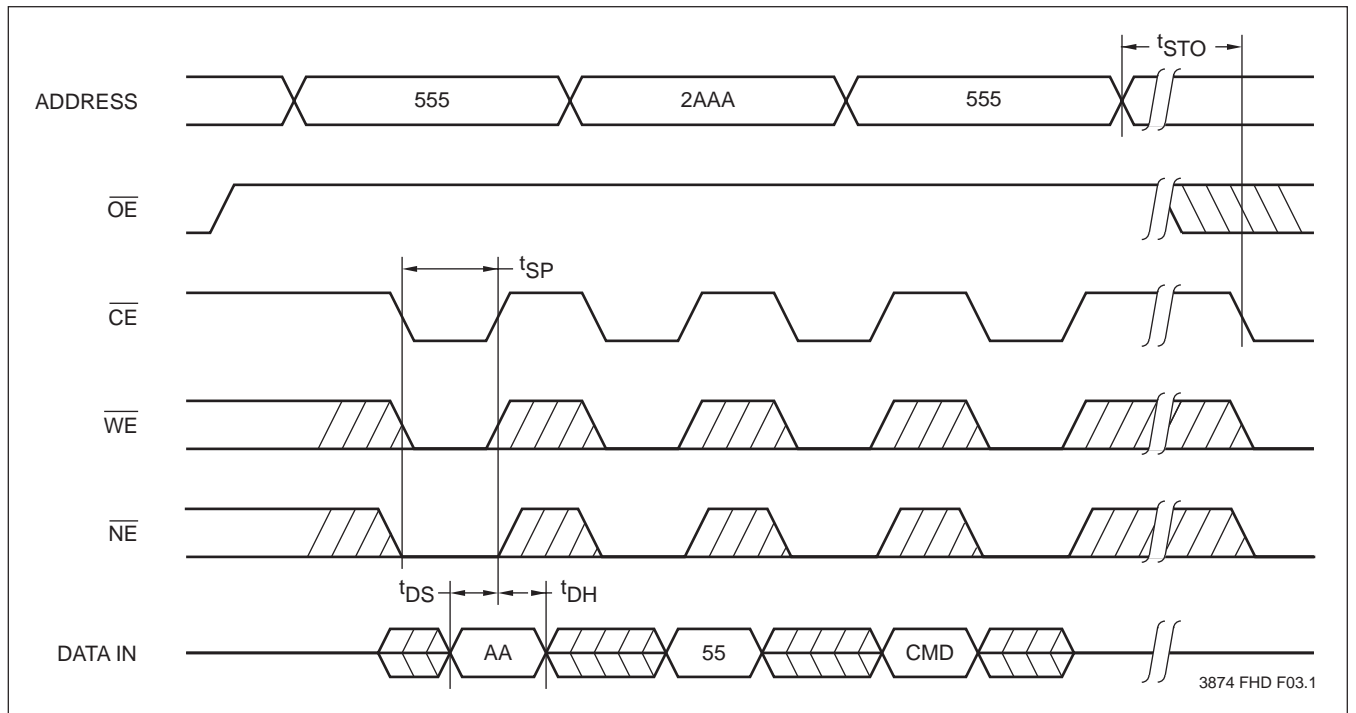

XM20C64

ABSOLUTE MAXIMUM RATINGS*

Temperature Under Bias	-65°C to +125°C
Storage Temperature	-65°C to +125°C
Voltage on any Pin with Respect to V _{SS}	-1V to +7V
Lead Temperature (Soldering, 10 seconds)	300°C

*COMMENT

Stresses above those listed under “Absolute Maximum Ratings” may cause permanent damage to the module. This is a stress rating only and the functional operation of the module at these or any other conditions above those indicated in the operational sections of this specification is not implied. Exposure to absolute maximum rating conditions for extended periods may affect module reliability.

RECOMMENDED OPERATING CONDITIONS

Temperature	Min.	Max.
Military	-55°C	+125°C

3874 PGM T06

Supply Voltage	Limits
XM20C64	5V ±10%

3874 PGM T07

D.C. OPERATING CHARACTERISTICS (Over recommended operating conditions unless otherwise specified.)

Symbol	Parameter	Limits			Test Conditions
		Min.	Max.	Units	
I _{CC1}	V _{CC} Active Current		100	mA	$\overline{NE} = \overline{WE} + V_{IH}$, $\overline{CE} = \overline{OE} = V_{IL}$, Address Inputs = TTL Inputs @ f = 20MHz All I/Os = Open
I _{CC2}	V _{CC} Active Current (AUTOSTORE)		10	mA	All Inputs = V _{IH} , All I/Os = Open
I _{SB}	V _{CC} Standby Current		1.5	mA	All Inputs = V _{CC} -0.3V All I/Os = Open
I _{LI}	Input Leakage Current		10	µA	V _{IN} = V _{SS} to V _{CC}
I _{LO}	Output Leakage Current		10	µA	V _{IN} = V _{SS} to V _{CC} , $\overline{CE} = V_{IH}$
V _{IL} (1)	Input LOW Voltage	-0.5	0.8	V	
V _{IH} (1)	Input HIGH Voltage	2	V _{CC} + 0.5	V	
V _{OL}	Output LOW Voltage		0.4	V	I _{OL} = 5mA
V _{OLAS}	AUTOSTORE Output Voltage		0.4	V	I _{OLAS} = 1mA
V _{OH}	Output HIGH Voltage	2.4		V	I _{OH} = -4mA

3874 PGM T08.2

POWER-UP TIMING

Symbol	Parameter	Max.	Units
t _{PUR}	Power-Up (V _{CC} Min.) to RAM Operation	500	µs
t _{PUST}	Power-Up (V _{CC} Min.) to Store Operation	5	ms

3874 PGM T09

CAPACITANCE T_A = +25°C, f = 1MHz, V_{CC} = 5V.

Symbol	Test	Max.	Units	Conditions
C _{I/O} (2)	Input/Output Capacitance	40	pF	V _{I/O} = 0V
C _{IN} (2)	Input Capacitance	24	pF	V _{IN} = 0V

3874 PGM T10.1

- Notes:** (1) V_{IL} min. and V_{IH} max. are for reference only and are not tested.
 (2) This parameter is periodically sampled and not 100% tested.

XM20C64

A.C. CHARACTERISTICS (Over the recommended operating conditions unless otherwise specified)

Read Cycle Limits

Symbol	Parameter	Limits		Units
		Min.	Max.	
t_{RC}	Read Cycle Time	55		ns
t_{CE}	Chip Enable Access Time		55	ns
t_{AA}	Address Access Time		55	ns
t_{OE}	Output Enable Access Time		30	ns
$t_{LZ}^{(3)}$	\overline{CE} Low to Output in Low Z	0		ns
$t_{OLZ}^{(3)}$	\overline{OE} Low to Output in Low Z	0		ns
$t_{HZ}^{(3)}$	\overline{CE} High to Output in Low Z	0	25	ns
$t_{OHZ}^{(3)}$	\overline{OE} High to Output in Low Z	0	25	ns
t_{OH}	Output Hold	0		ns

3874 PGM T03

Read Cycle Timing Diagram

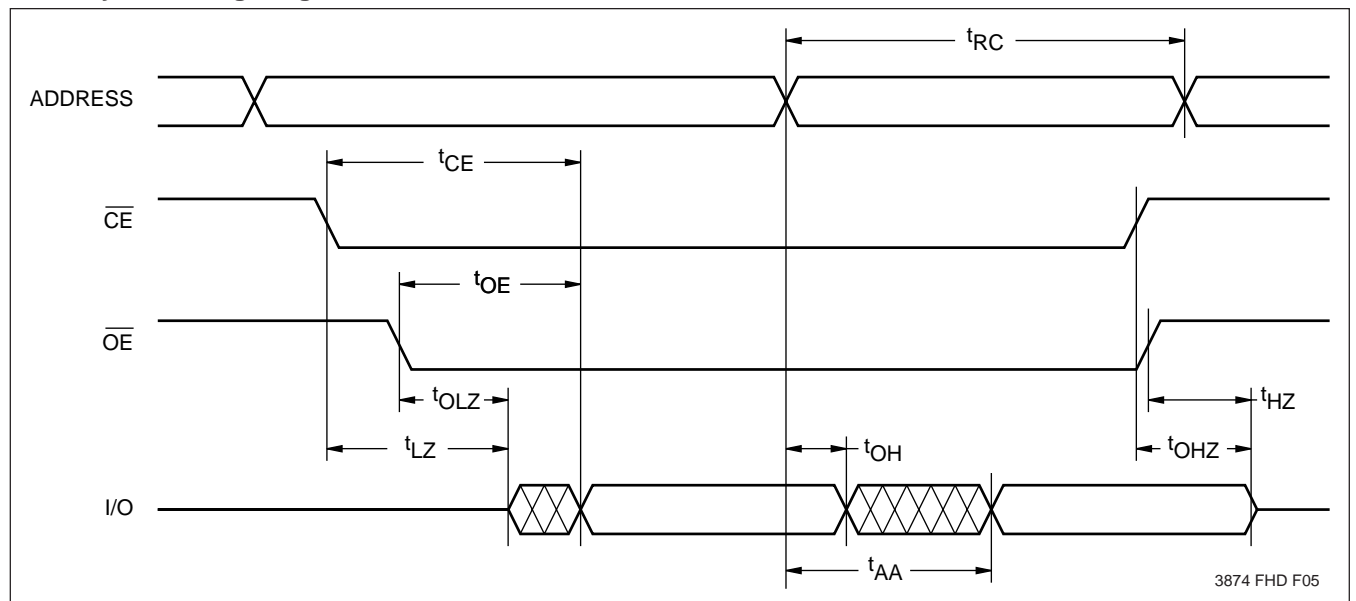

3874 FHD F05

Note: (3) t_{LZ} min., t_{HZ} min., t_{OLZ} min., and t_{OHZ} min. are periodically sampled and not 100% tested. t_{HZ} max. and t_{OHZ} max. are measured from the point when \overline{CE} or \overline{OE} return high (whichever occurs first) to the time when the outputs are no longer driven.

MODE SELECTION

\overline{CE}	\overline{WE}	\overline{NE}	\overline{OE}	Mode	I/O State	Power
H	X	X	X	Module Not Selected	High Z	Standby
L	H	H	L	Read RAM Active	Data Output	Active
L	L	H	X	Write RAM	Data Input	Active
L	L	L	H	Issue Software Command	Data Input	Active
L	H	H	H	Output Disabled	High Z	Active
L	H	L	L	Hardware Array Recall	High Z	Active
L	H	L	H	No Operation	High Z	Active
L	L	L	L	Not Allowed	High Z	Active

3874 PGM T04.1

XM20C64

Write Cycle Limits

Symbol	Parameter	Limits		Units
		Min.	Max.	
t_{WC}	Write Cycle time	55		ns
t_{WP}	\overline{WE} Pulse Width	40		ns
t_{CW}	\overline{CE} Pulse Width	40		ns
t_{AS}	Address Setup	0		ns
t_{DS}	Data Setup	25		ns
t_{DH}	Data Hold	0		ns
t_{OW}	Output Active from End of Write		5	ns
t_{WR}	End of Write to Read	0		ns

3874 PGM T02

Write Cycle Timing Diagram

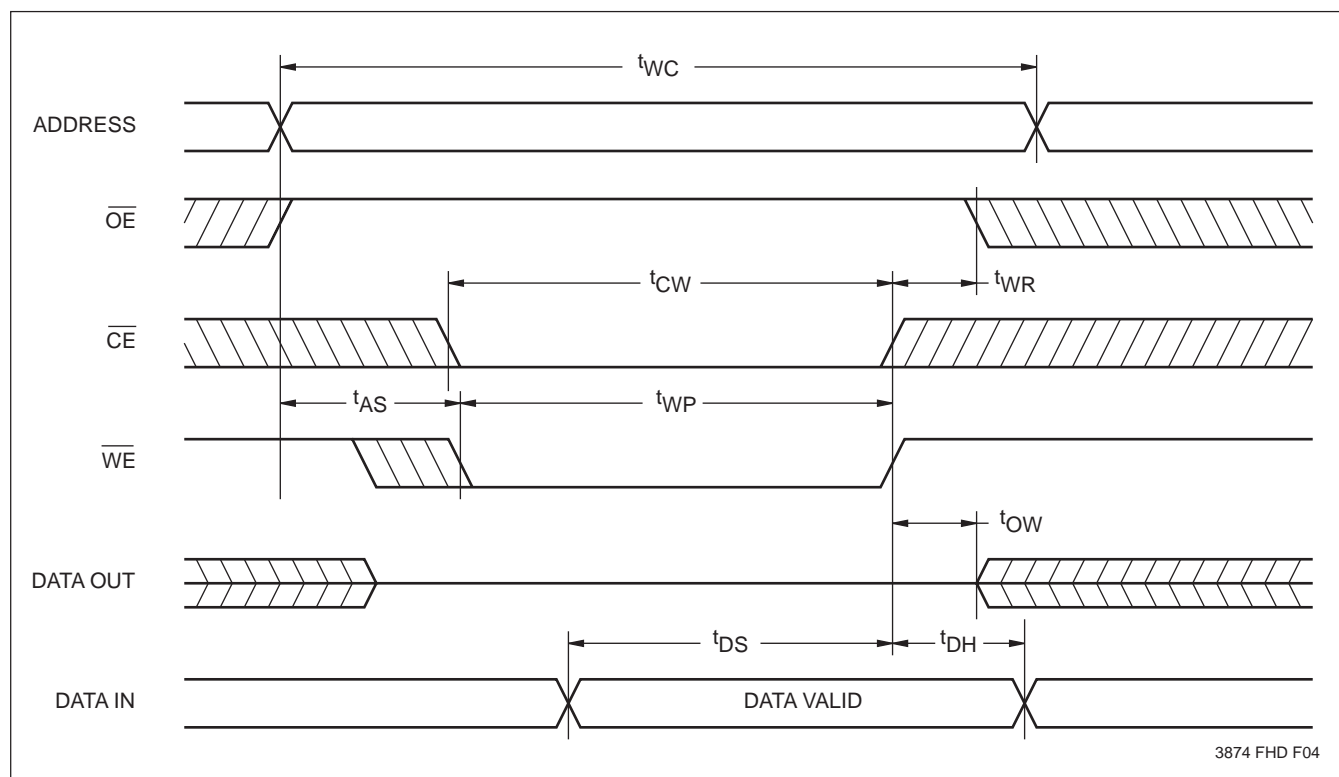

3874 FHD F04

XM20C64

Array Recall Timing

Symbol	Parameter	Limits		Units
		Min.	Max.	
t_{RCC}	Array Recall Time		10	μ s
t_{RCP}	Recall Strobe Pulse Width	50		ns
t_{RWE}	Delay From \overline{WE} HIGH to Recall	0		ns

3874 PGM T05.1

Note: The recall sequence must be repeated for each memory component individually. This is accomplished by sequencing through the Array Recall Cycle with all four combinations of A_{11} , and A_{12} .

Array Recall Cycle

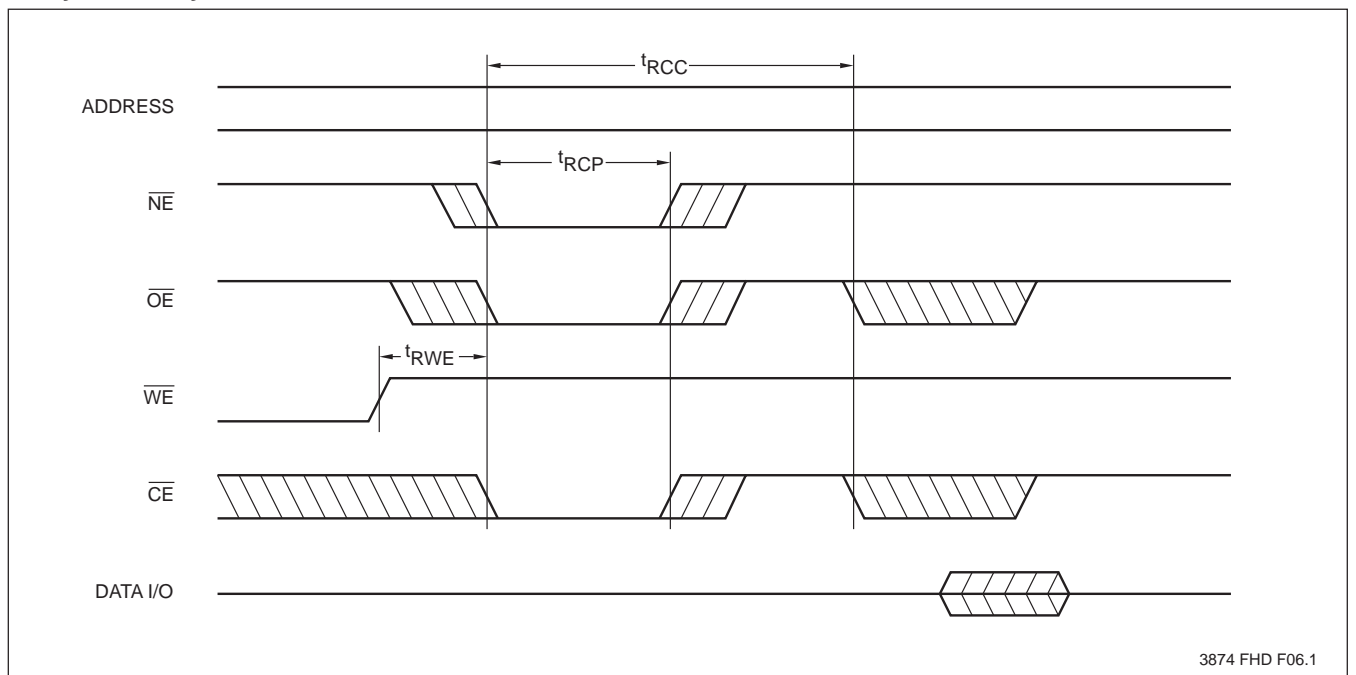

3874 FHD F06.1

EQUIVALENT TEST LOAD CIRCUIT

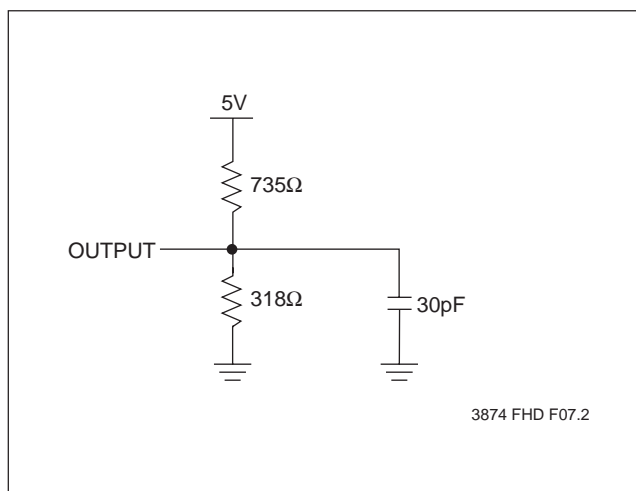

3874 FHD F07.2

SYMBOL TABLE

WAVEFORM	INPUTS	OUTPUTS
	Must be steady	Will be steady
	May change from LOW to HIGH	Will change from LOW to HIGH
	May change from HIGH to LOW	Will change from HIGH to LOW
	Don't Care: Changes Allowed	Changing: State Not Known
	N/A	Center Line is High Impedance

XM20C64P

PIN CONFIGURATION

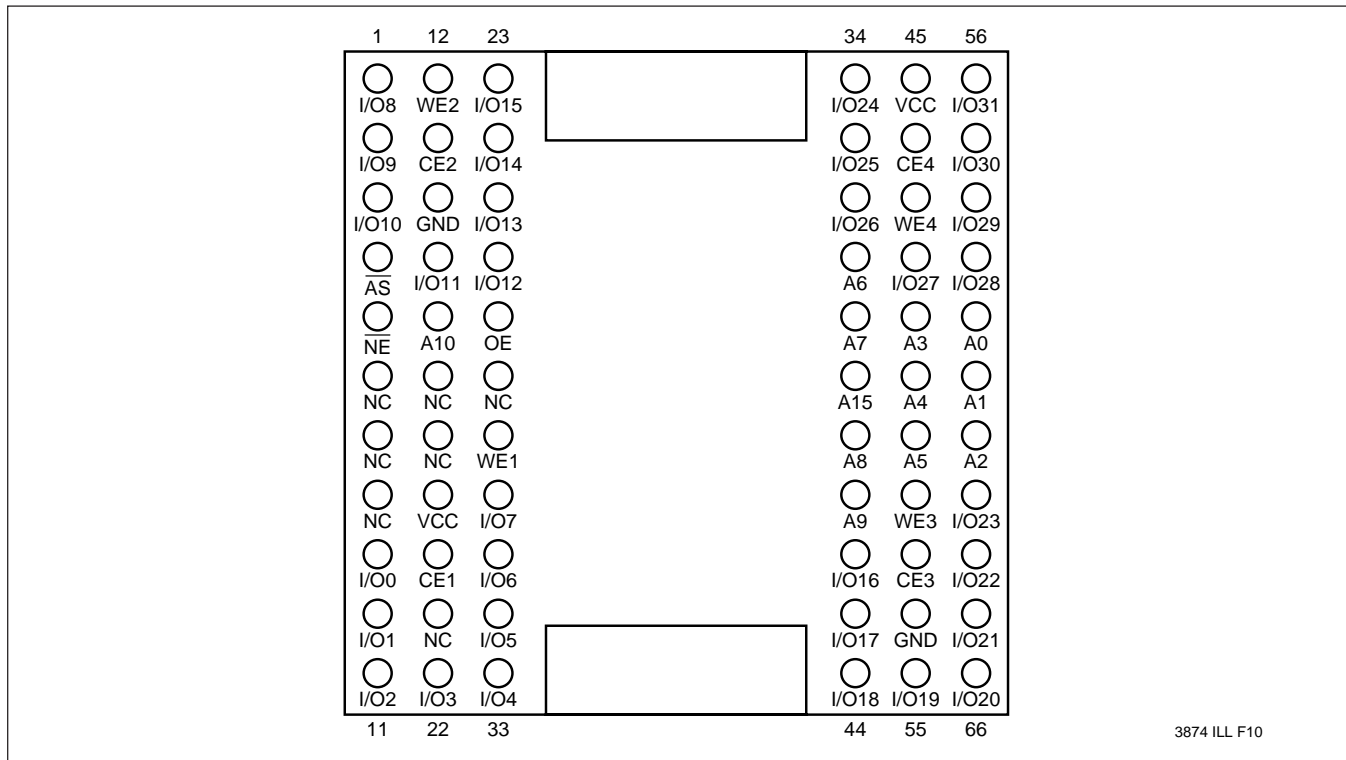

PACKAGING INFORMATION

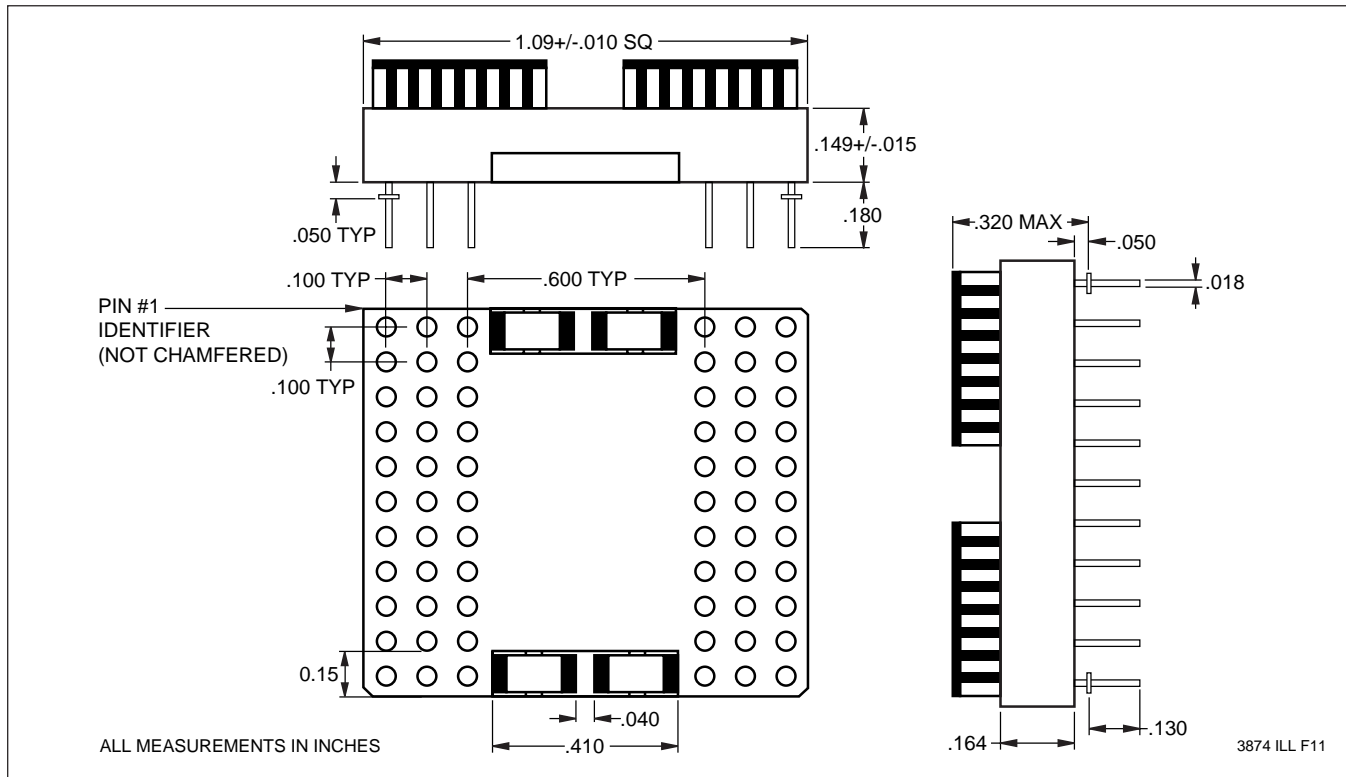

XM20C64

PACKAGING INFORMATION

28-PIN DUAL-IN-LINE PACKAGE CERAMIC LEADLESS CHIP CARRIERS ON CERAMIC SIDEBRAZED CERAMIC SUBSTRATE

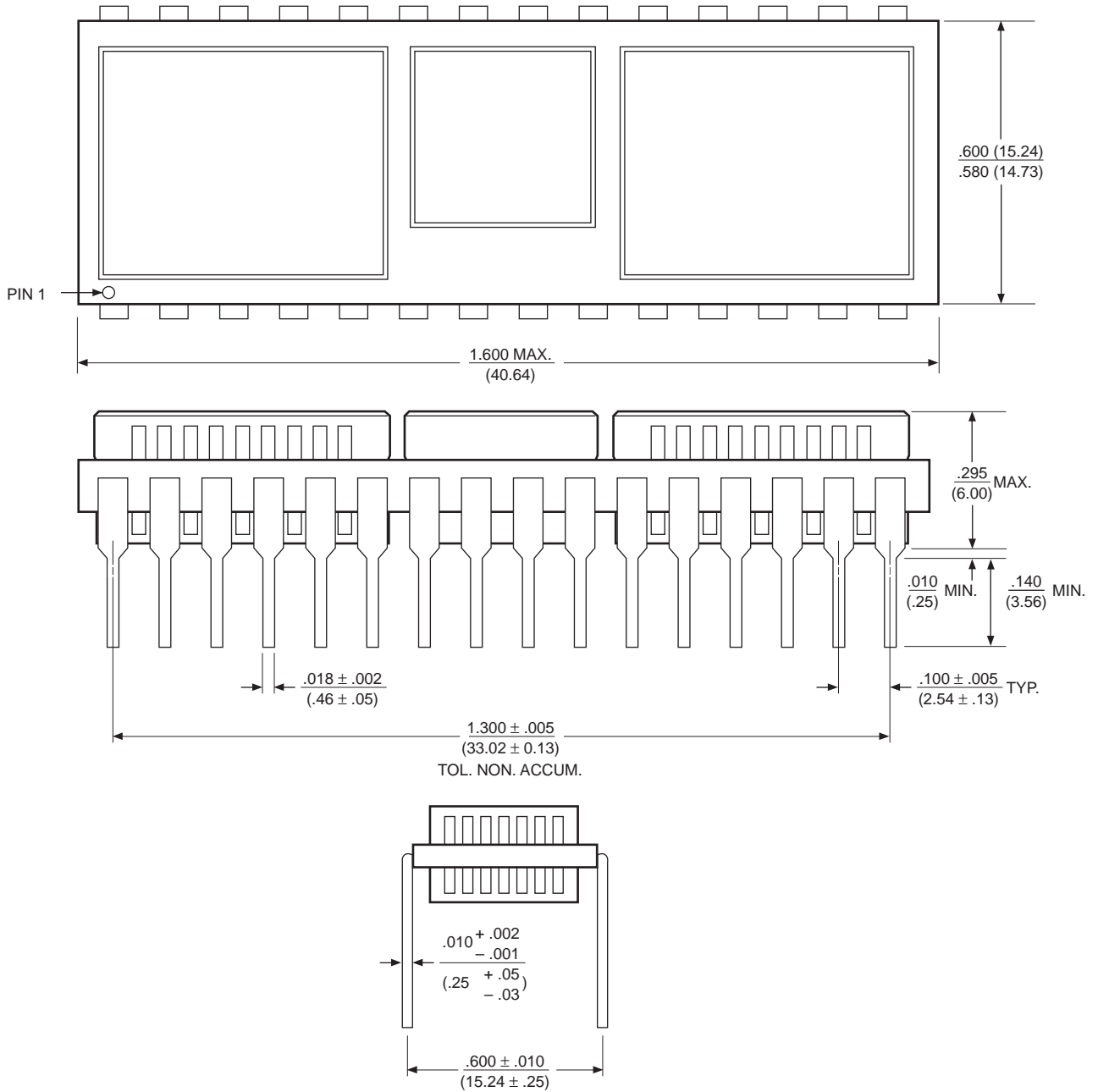

NOTES:

1. ALL DIMENSIONS IN INCHES (IN PARENTHESES IN MILLIMETERS)
2. DIMENSIONS WITH NO TOLERANCE FOR REFERENCE ONLY

XM20C64

ORDERING INFORMATION

XM20C64: 2K X 8 CMOS NOVRAM Memory Module

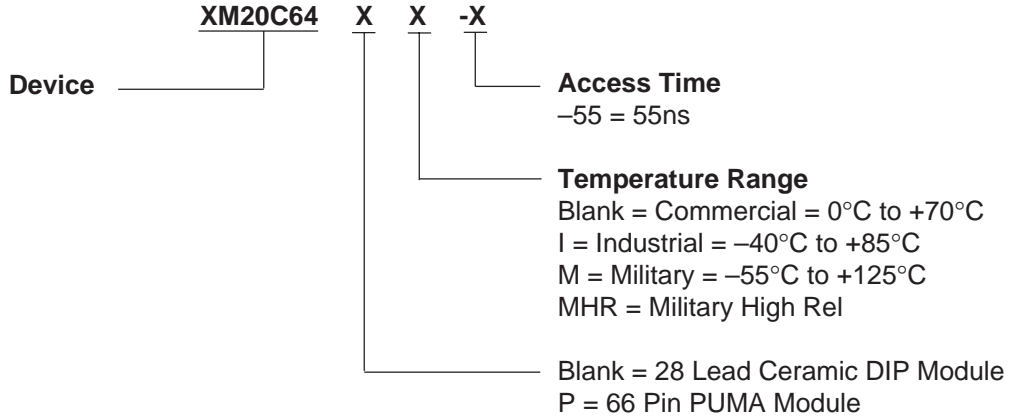

LIMITED WARRANTY

Devices sold by Xicor, Inc. are covered by the warranty and patent indemnification provisions appearing in its Terms of Sale only. Xicor, Inc. makes no warranty, express, statutory, implied, or by description regarding the information set forth herein or regarding the freedom of the described devices from patent infringement. Xicor, Inc. makes no warranty of merchantability or fitness for any purpose. Xicor, Inc. reserves the right to discontinue production and change specifications and prices at any time and without notice.

Xicor, Inc. assumes no responsibility for the use of any circuitry other than circuitry embodied in a Xicor, Inc. product. No other circuits, patents, licenses are implied.

U.S. PATENTS

Xicor products are covered by one or more of the following U.S. Patents: 4,263,664; 4,274,012; 4,300,212; 4,314,265; 4,326,134; 4,393,481; 4,404,475; 4,450,402; 4,486,769; 4,488,060; 4,520,461; 4,533,846; 4,599,706; 4,617,652; 4,668,932; 4,752,912; 4,829,482; 4,874,967; 4,883,976. Foreign patents and additional patents pending.

LIFE RELATED POLICY

In situations where semiconductor component failure may endanger life, system designers using this product should design the system with appropriate error detection and correction, redundancy and back-up features to prevent such an occurrence.

Xicor's products are not authorized for use in critical components in life support devices or systems.

1. Life support devices or systems are devices or systems which, (a) are intended for surgical implant into the body, or (b) support or sustain life, and whose failure to perform, when properly used in accordance with instructions for use provided in the labeling, can be reasonably expected to result in a significant injury to the user.
2. A critical component is any component of a life support device or system whose failure to perform can be reasonably expected to cause the failure of the life support device or system, or to affect its safety or effectiveness.